

Air Cylinder: Standard Type Double Acting, Single Rod

CM2 Series

ø20, ø25, ø32, ø40



How to Order

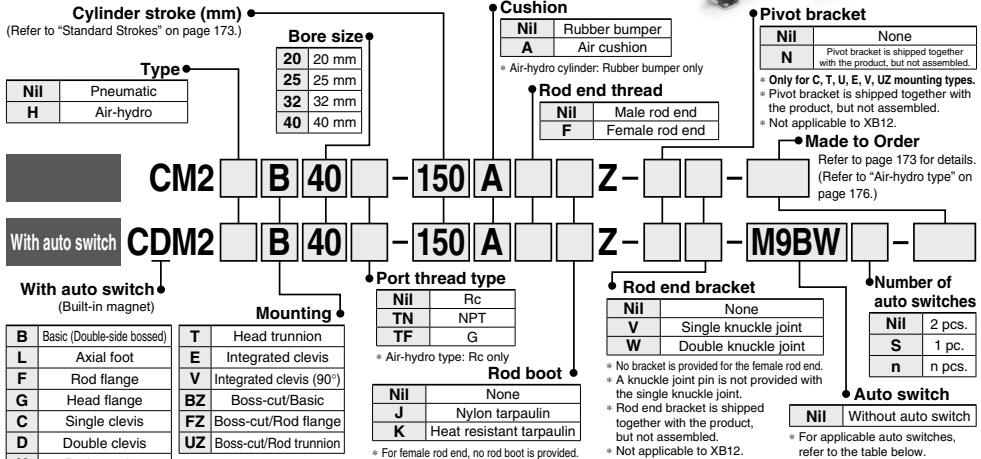

* Refer to "Ordering Example of Cylinder Assembly" on page 173.

Applicable Auto Switches/Refer to pages 1575 to 1701 for further information on auto switches.

Type	Special function	Electrical entry	Indicator light	Wiring (Output)	Load voltage		Auto switch model		Lead wire length (m)					Pre-wired connector	Applicable load					
					DC	AC	Perpendicular	In-line	0.5 (Nil)	1 (M)	3 (L)	5 (Z)	None (N)							
																DC	AC			
Solid state auto switch	—	Grommet	Yes	3-wire (NPN)	5 V, 12 V	—	M9NV	M9N	●	●	○	○	○	IC circuit	Relay, PLC					
				3-wire (PNP)			M9PV	M9P	●	●	○	○								
		Connector		2-wire	12 V	M9BV	M9B	●	●	●	●	—	—			—				
				Terminal conduit		—	H7C	●	●	●	●	—	—			—				
		Diagnostic indication (2-color indicator)		Grommet	Yes	3-wire (NPN)	5 V, 12 V	—	—	G39A	—	—	—			—	●	—	IC circuit	
	3-wire (PNP)		—			K39A			—	—	—	●	—	—		—				
	Water resistant (2-color indicator)		Grommet	2-wire		12 V	M9NV	M9NW	●	●	●	○	○	○		—	IC circuit			
				3-wire (PNP)			M9PV	M9PW	●	●	●	○	○	○		—	IC circuit			
				2-wire			M9BV	M9B	●	●	●	○	○	○		—	—			
	With diagnostic output (2-color indicator)	Grommet	Yes	4-wire (NPN)	5 V, 12 V	—	—	M9NAV*1	M9NA*1	○	○	○	○	○		—	IC circuit			
3-wire (PNP)				M9PAV*1			M9PA*1	○	○	○	○	○	○	—	IC circuit					
2-wire				M9BAV*1			M9BA*1	○	○	○	○	○	○	○	—	—				
—				—			H7NF	●	●	●	○	○	○	○	—	IC circuit				
—				—			—	—	—	—	—	—	—	—	—	—	—			
Reed auto switch	—	Grommet	Yes	3-wire (NPN equivalent)	5 V	—	A96V	A96	●	●	●	—	—	—	IC circuit	Relay, PLC				
							Connector	100 V	A93V*2	A93	●	●	●	●	—		—	—		
								100 V or less	A90V	A90	●	●	●	—	—		—	—	IC circuit	
								100 V, 200 V	—	B54	●	●	●	—	—		—	—	—	
								200 V or less	—	B64	●	●	●	—	—		—	—	—	
		Terminal conduit		Grommet	Yes	2-wire	24 V	12 V	—	C73C	●	●	●	●	—		—	—	—	
									—	C80C	●	●	●	●	—		—	—	IC circuit	
									—	A33A	—	—	—	—	●		—	—	—	PLC
									100 V, 200 V	—	A34A	—	—	—	—		●	—	—	—
									—	—	A44A	—	—	—	—		—	●	—	—
Diagnostic indication (2-color indicator)	Grommet	Yes	—	—	—	—	B59W	●	●	—	—	—	—							

*1 Water resistant type auto switches can be mounted on the above models, but in such case SMC cannot guarantee water resistance.

A water-resistant type cylinder is recommended for use in an environment which requires water resistance.

*2 1 m type lead wire is only applicable to D-A93.

* Lead wire length symbols: 0.5 m Nil (Example) M9NW
1 m M (Example) M9NWM
3 m L (Example) M9NLW
5 m Z (Example) M9NZW
None N (Example) H7CN

* Solid state auto switches marked with "○" are produced upon receipt of order.

* Do not indicate suffix "N" for no lead wire on the D-A93/A44A/G39A/K39A models.

* Since there are other applicable auto switches than listed above, refer to page 266 for details.

* For details about auto switches with pre-wired connector, refer to pages 1648 and 1649.

* The D-A9□□/M9□□□ auto switches are shipped together, (but not assembled). (However, only the auto switch mounting brackets are assembled before shipment.)

Specifications



Symbol

Double acting, Single rod

Air cushion

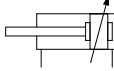
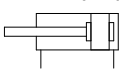

Refer to pages 262 to 266 for cylinders with auto switches

- Auto switch proper mounting position (detection at stroke end) and its mounting height
- Minimum stroke for auto switch mounting
- Operating range
- Auto switch mounting brackets/Part no.



Made to Order: Individual Specifications
(For details, refer to page 267.)

Symbol	Specifications
-X446	PTFE grease

Made to Order

[Click here for details](#)

Symbol	Specifications
-XA□	Change of rod end shape
-XB6	Heat resistant cylinder (-10 to 150°C)
-XB7	Cold resistant cylinder (-40 to 70°C) ^{*1}
-XB9	Low speed cylinder (10 to 50 mm/s) ^{*1}
-XB12	External stainless steel cylinder ^{*2}
-XC3	Special port location
-XC4	With heavy duty scraper
-XC5	Heat resistant cylinder (-10 to 110°C)
-XC6	Made of stainless steel
-XC8	Adjustable stroke cylinder/Adjustable extension type
-XC9	Adjustable stroke cylinder/Adjustable retraction type
-XC10	Dual stroke cylinder/Double rod type ^{*1}
-XC11	Dual stroke cylinder/Single rod type
-XC12	Tandem cylinder ^{*1}
-XC13	Auto switch rail mounting
-XC20	Head cover axial port
-XC22	Fluororubber seal
-XC25	No fixed throttle of connection port ^{*1}
-XC27	Double clevis and double knuckle pins made of stainless steel
-XC29	Double knuckle joint with spring pin
-XC35	With coil scraper ^{*1}
-XC52	Mounting nut with set screw
-XC85	Grease for food processing equipment

^{*1} Rubber bumper only.

^{*2} The shape is the same as the current product.

Bore size (mm)		20	25	32	40
Type		Pneumatic			
Action		Double acting, Single rod			
Fluid		Air			
Proof pressure		1.5 MPa			
Maximum operating pressure		1.0 MPa			
Minimum operating pressure		0.05 MPa			
Ambient and fluid temperature		Without auto switch: -10°C to 70°C With auto switch: -10°C to 60°C (No freezing)			
Lubrication		Not required (Non-lube)			
Stroke length tolerance		+ ^{-1.4} / ₀ mm			
Piston speed		Rubber bumper: 50 to 750 mm/s, Air cushion: 50 to 1000 mm/s			
Cushion		Rubber bumper, Air cushion			
Allowable kinetic energy	Rubber bumper	0.27 J	0.4 J	0.65 J	1.2 J
	Male thread	0.11 J	0.18 J	0.29 J	0.52 J
	Female thread	0.54 J (11.0)	0.78 J (11.0)	1.27 J (11.0)	2.35 J (11.8)
	Air cushion (Effective cushion length (mm))	0.11 J	0.18 J	0.29 J	0.52 J

* Operate the cylinder with in the allowable kinetic energy.

Standard Strokes

Bore size (mm)	Standard stroke (mm) ^{Note 1)}	Maximum manufacturable stroke (mm)
20	25, 50, 75, 100, 125, 150, 200, 250, 300	1000
25		1500
32		2000
40		

Note 1) Intermediate strokes not listed above are produced upon receipt of order.

Manufacture of intermediate strokes in 1 mm increments is possible. (Spacers are not used.)

Note 2) Applicable strokes should be confirmed according to the usage. For details, refer to "Air Cylinders Model Selection" on front matter pages. In addition, the products that exceed the standard stroke might not be able to fulfill the specifications due to the deflection etc.

Rod Boot Material

Symbol	Rod boot material	Maximum ambient temperature
J	Nylon tarpaulin	70°C
K	Heat resistant tarpaulin	110°C ^{*1}

^{*1} Maximum ambient temperature for the rod boot itself.

Option: Ordering Example of Cylinder Assembly

Cylinder model: CDM2C20-50Z-NV-M9BW

Mounting C: Single clevis
Pivot bracket N: Yes
Rod end bracket V: Single knuckle joint
Auto switch D-M9BW: 2 pcs.

^{*} Pivot bracket, single knuckle joint and auto switch are shipped together with the product, but not assembled.

^{*} Pivot bracket is available only for C, T, U, E, V, UZ mounting types.

^{*} No bracket is provided for the female rod end.

Mounting and Accessories

Accessories	Standard (mounted to the body)							Standard (packaged together, but not assembled)							Option			
	Body	Mounting nut	Rod end nut (Male thread)	Single clevis	Double clevis	Liner	Mounting nut	Foot	Flange	Pivot bracket	Pivot bracket pin	Double clevis pin	Trunnion	Mounting nut (For trunnion)	Clevis pivot bracket (CM2E/CM2V)	Clevis pivot bracket pin (CM2E/CM2V)	Single knuckle joint (Male thread only)	Double knuckle joint (Male thread only)
B Basic (Double-side bossed)	●(1 pc.)	●(1 pc.)	●(1 pc.)	—	—	—	—	—	—	—	—	—	—	—	—	—	●	●
L Axial foot	●(1 pc.)	●(1 pc.) ^{Note 3}	●(1 pc.)	—	—	—	●(1 pc.)	●(2 pcs.)	—	—	—	—	—	—	—	—	●	●
F Rod flange	●(1 pc.)	●(1 pc.)	●(1 pc.)	—	—	—	—	—	—	—	—	—	—	—	—	—	●	●
G Head flange	●(1 pc.)	●(1 pc.)	●(1 pc.)	—	—	—	—	—	—	—	—	—	—	—	—	—	●	●
C Single clevis	●(1 pc.)	— ^{Note 3}	●(1 pc.)	●(1 pc.)	—	—	—	—	—	—	—	—	—	—	—	—	●	●
D Double clevis	●(1 pc.)	— ^{Note 3}	●(1 pc.)	—	●(1 pc.)	—	—	—	—	—	—	—	—	—	—	—	●	●
U Rod trunnion	●(1 pc.)	— ^{Note 4}	●(1 pc.)	—	—	—	—	—	—	—	—	—	—	—	—	—	●	●
T Head trunnion	●(1 pc.)	— ^{Note 4}	●(1 pc.)	—	—	—	—	—	—	—	—	—	—	—	—	—	●	●
E Integrated clevis	●(1 pc.)	— ^{Note 3}	●(1 pc.)	—	—	—	—	—	—	—	—	—	—	—	—	—	●	●
V Integrated clevis (90°)	●(1 pc.)	— ^{Note 3}	●(1 pc.)	—	—	—	—	—	—	—	—	—	—	—	—	—	●	●
BZ Boss-cut/Basic	●(1 pc.)	●(1 pc.)	●(1 pc.)	—	—	—	—	—	—	—	—	—	—	—	—	—	●	●
FZ Boss-cut/Rod flange	●(1 pc.)	●(1 pc.)	●(1 pc.)	—	—	—	—	—	—	—	—	—	—	—	—	—	●	●
UZ Boss-cut/Rod trunnion	●(1 pc.)	— ^{Note 4}	●(1 pc.)	—	—	—	—	—	—	—	—	—	—	—	—	—	●	●

	Standard (mounted to the body)							Option											
Mounting: C Pivot bracket symbol: N Single clevis + Pivot bracket + Pin	●(1 pc.)	— ^{Note 3}	●(1 pc.)	●(1 pc.)	—	—	—	●(Max. 3 pcs.)	— ^{Note 3}	—	—	—	—	—	—	—	—	●	●
Mounting: T, U, UZ Pivot bracket symbol: N Trunnion + Pivot bracket	●(1 pc.)	— ^{Note 4}	●(1 pc.)	—	—	—	—	—	—	—	—	—	—	—	—	—	—	●	●
Mounting: E Pivot bracket symbol: N Integrated clevis + Pivot bracket + Pin	●(1 pc.)	— ^{Note 3}	●(1 pc.)	—	—	—	—	—	—	—	—	—	—	—	—	—	—	●(1 pc.)	●(1 pc.)
Mounting: V Pivot bracket symbol: N Integrated clevis (90°) + Pivot bracket + Pin	●(1 pc.)	— ^{Note 3}	●(1 pc.)	—	—	—	—	—	—	—	—	—	—	—	—	—	—	●(1 pc.)	●(1 pc.)

Note 1) Rod end nut is not provided for the female rod end.
 Note 2) Two mounting nuts are packaged together.
 Note 3) Mounting nut is not packaged for the clevis.
 Note 4) Trunnion nut is packaged for U, T, UZ.
 Note 5) Retaining rings are included.

Note 6) A pin and retaining rings (split pins for ø40) are included.
 Note 7) This is the part(s) used to adjust the clevis angle. Mounting quantity can vary.
 * Stainless steel mounting brackets and accessories are also available.
 Refer to page 190 for details.

Mounting Brackets/Part No.

Mounting bracket	Min. order qty	Bore size (mm)				Contents (for minimum order quantity)
		20	25	32	40	
Foot*	2	CM-L020B	CM-L032B	CM-L040B	2 feet, 1 mounting nut	
Flange	1	CM-F020B	CM-F032B	CM-F040B	1 flange	
Single clevis**	1	CM-C020B	CM-C032B	CM-C040B	1 single clevis, 3 liners	
Double clevis (with pin)***	1	CM-D020B	CM-D032B	CM-D040B	1 double clevis, 3 liners, 1 clevis pin, 2 retaining rings	
Double clevis pin	1	CDP-1			1 clevis pin, 2 retaining rings (split pins)	
Trunnion (with nut)	1	CM-T020B	CM-T032B	CM-T040B	1 trunnion, 1 retaining ring	
Rod end nut	1	NT-02	NT-03	NT-04	1 rod end nut	
Mounting nut	1	SN-020B	SN-032B	SN-040B	1 mounting nut	
Trunnion nut	1	TN-020B	TN-032B	TN-040B	1 trunnion nut	
Single knuckle joint	1	I-020B	I-032B	I-040B	1 single knuckle joint	
Double knuckle joint	1	Y-020B	Y-032B	Y-040B	1 double knuckle joint, 1 knuckle pin, 2 retaining rings	
Double knuckle joint pin	1	CDP-1			1 knuckle pin, 2 retaining rings (split pins)	
Clevis pivot bracket pin (For CM2E/CM2V)	1	CD-S02		CD-S03	1 clevis pin, 2 retaining rings	
Clevis pivot bracket (For CM2E/CM2V)	1	CM-E020B		CM-E032B	1 clevis pivot bracket, 1 clevis pin, 2 retaining rings	
Pivot bracket (For CM2C)	1	CM-B032			2 pivot brackets (1 of each type)	
Pivot bracket pin (For CM2C)	1	CDP-1			1 pin, 2 retaining rings	
Pivot bracket (For CM2T/CM2U)	1	CM-B020	CM-B032	CM-B040	2 pivot brackets (1 of each type)	

* Order 2 feet per cylinder.
 ** 3 liners are included with a clevis bracket for adjusting the mounting angle.
 *** A clevis pin and retaining rings (split pins for ø40) are included.

For dimensions of accessories (options), refer to pages 189 and 190.

Mounting Brackets, Accessories/Material, Surface Treatment

Segment	Description	Material	Surface treatment
Mounting brackets	Foot	Carbon steel	Nickel plating
	Flange	Carbon steel	Nickel plating
	Single clevis	Carbon steel	Nickel plating
	Double clevis	Carbon steel	Nickel plating
	Trunnion	Cast iron	Electroless nickel plating
Accessories	Rod end nut	Carbon steel	Zinc chromated
	Mounting nut	Carbon steel	Nickel plating
	Trunnion nut	Carbon steel	Nickel plating
	Clevis pivot bracket	Carbon steel	Nickel plating
	Clevis pivot bracket pin	Carbon steel	(None)
	Single knuckle joint	Carbon steel ø40: Free-cutting steel	Electroless nickel plating
	Double knuckle joint	Carbon steel ø40: Cast iron	Electroless nickel plating Metallic silver color painting for ø40
	Double clevis pin	Carbon steel	(None)
	Double knuckle joint pin	Carbon steel	(None)
	Pivot bracket	Carbon steel	Nickel plating
	Pivot bracket pin	Carbon steel	(None)

Weights

		(kg)			
		20	25	32	40
Basic weight	Bore size (mm)				
	Basic (Double-side bossed)	0.14	0.21	0.28	0.56
	Axial foot	0.29	0.37	0.44	0.83
	Flange	0.20	0.30	0.37	0.68
	Integrated clevis	0.12	0.19	0.27	0.52
	Single clevis	0.18	0.25	0.32	0.65
	Double clevis	0.19	0.27	0.33	0.69
	Trunnion	0.18	0.28	0.34	0.66
	Boss-cut/Basic	0.13	0.19	0.26	0.53
	Boss-cut/Flange	0.19	0.28	0.35	0.65
Boss-cut/Trunnion	0.17	0.26	0.32	0.63	
Additional weight per 50 mm of stroke		0.04	0.06	0.08	0.13
Weight reduction for female rod end		-0.01	-0.02	-0.02	-0.04
Option bracket	Clevis pivot bracket (with pin)	0.07	0.07	0.14	0.14
	Single knuckle joint	0.06	0.06	0.06	0.23
	Double knuckle joint (with pin)	0.07	0.07	0.07	0.20
	Pivot bracket	0.06	0.06	0.06	0.06
	Pivot bracket pin	0.02	0.02	0.02	0.03

Calculation: (Example) **CM2L32-100Z**
 ● Basic weight.....0.44 (Foot, ø32)
 ● Additional weight.....0.08/50 stroke
 ● Cylinder stroke.....100 stroke
 $0.44 + 0.08 \times 100/50 = 0.60 \text{ kg}$

CJ1
CJP
CJ2
JCM
CM2
CM3
CG1
CG3
JMB
MB
MB1
CA2
CS1
CS2

⚠ Precautions

Be sure to read this before handling the products. Refer to back page 50 for Safety Instructions and pages 3 to 12 for Actuator and Auto Switch Precautions.

Handling

⚠ Warning

- Do not rotate the cover.**
If a cover is rotated when installing a cylinder or screwing a fitting into the port, it is likely to damage the junction part with cover.
- Operate the cylinder within the specified cylinder speed, kinetic energy and lateral load at the rod end.**
- The allowable kinetic energy is different between the cylinders with male rod end and with female rod end due to the different thread sizes.**
- When female rod end is used, use a washer, etc. to prevent the contact part at the rod end from being deformed depending on the material of the workpiece.**
- Do not apply excessive lateral load to the piston rod.**
Easy checking method
Minimum operating pressure after the cylinder is mounted to the equipment (MPa) = Minimum operating pressure of cylinder (MPa) + (Load mass (kg) x Friction coefficient of guide/Sectional area of cylinder (mm²))
If smooth operation is confirmed within the above value, the load on the cylinder is the resistance of the thrust only and it can be judged as having no lateral load.
- Do not operate with the cushion needle in a fully closed condition.**
Using it in the fully closed state will cause the cushion seal to be damaged. When adjusting the cushion needle, use the "Hexagon wrench key: nominal size 1.5".
- Do not open the cushion needle wide excessively.**
If the cushion needle were set to be completely wide (more than 3 turns from fully closed), it would be equivalent to the cylinder with no cushion, thus making the impacts extremely high. Do not use it in such a way. Besides, using with fully open could give damage to the piston or cover.
- Do not open the cushion needle after rotating it numerous times in a row. Though uncommon, there are cases in which the cushion needle may leak air.**
The cushion needle should be adjusted by gradually opening it while checking the operation of the cylinder cushion. In the unlikely event that air leakage occurs, return the cushion needle to the fully-closed state, and readjust the cushion needle to the desired position.

⚠ Caution

- Not able to disassemble.**
Cover and cylinder tube are connected to each other by caulking method, thus making it impossible to disassemble. Therefore, internal parts of a cylinder other than rod seal are not replaceable.
- Use caution to the popping of a retaining ring.**
When replacing rod seals and removing and mounting a retaining ring, use a proper tool (retaining ring plier: tool for installing a type C retaining ring). Even if a proper tool is used, it is likely to inflict damage to a human body or peripheral equipment, as a retaining ring may be flown out of the tip of a plier. Be much careful with the popping of a retaining ring. Besides, be certain that a retaining ring is placed firmly into the groove of rod cover before supplying air at the time of installation.
- Do not touch the cylinder during operation.**
Use caution when handling a cylinder, which is running at a high speed and a high frequency, because the surface of a cylinder tube could get so hot enough as to cause you get burned.
- Do not use the air cylinder as an air-hydro cylinder.**
If it uses turbine oil in place of fluids for cylinder, it may result in oil leak.
- The oil stuck to the cylinder is grease.**
- The base oil of grease may seep out.**
The base oil of grease in the cylinder may seep out of the tube, cover, crimped part or rod bushing depending on the operating conditions (ambient temperature 40°C or more, pressurized condition, low frequency operation).
- When rod end female thread is used, use a thin wrench when tightening the piston rod.**
- Combine the rod end section, so that a rod boot might not be twisted.**
If a rod boot is installed with being twisted when installing a cylinder, it will cause a rod boot to fail during operation.
- When using a rod end bracket and/or pivot bracket, make sure they do not interfere with other brackets, workpieces and rod section, etc.**

D-□
-X□
Technical Data

CM2 Series

Built-in One-touch Fittings (The shape is the same as the current product.)

CM2 F —
 ↓
 Built-in One-touch fittings

This type has the One-touch fitting integrated in a cylinder, which enables to reduce the piping labor and installing space dramatically.



Specifications

Action	Double acting, Single rod
Bore size (mm)	ø20, ø25, ø32, ø40
Max. operating pressure	1.0 MPa
Min. operating pressure	0.05 MPa
Cushion	Rubber bumper
Piping	One-touch fittings
Piston speed	50 to 750 mm/s
Mounting	Basic, Axial foot, Rod flange, Head flange, Single clevis, Double clevis, Rod trunnion, Head trunnion, Integrated clevis, Boss-cut

* Auto switch can be mounted.

Applicable Tubing O.D./I.D.

Bore size (mm)	20	25	32	40
Applicable tubing O.D./I.D. (mm)	6/4	6/4	6/4	8/6
Applicable tubing material	Can be used for either nylon, soft nylon or polyurethane tubing.			

⚠ Caution

- One-touch fitting cannot be replaced.
 - One-touch fitting is press-fit into the cover, thus cannot be replaced.
- Refer to Fittings and Tubing Precautions (Best Pneumatics No. 7) for handling One-touch fittings.

Air-hydro

CM2H — Z —
 ↓
 Air-hydro

A low hydraulic pressure cylinder used at a pressures of 1.0 MPa or below.

Through the concurrent use of the CC series air-hydro unit, it is possible to operate at a constant or low speeds or to effect an intermediate stop, just like a hydraulic unit, while using pneumatic equipment such as a valve.



- For construction, refer to page 179.
- Since the dimensions of mounting type are the same as pages 181 to 188, refer to those pages.

Specifications

Type	Air-hydro	
Fluid	Turbine oil	
Action	Double acting, Single rod	
Bore size (mm)	ø20, ø25, ø32, ø40	
Proof pressure	1.5 MPa	
Max. operating pressure	1.0 MPa	
Min. operating pressure	0.18 MPa	
Piston speed	15 to 300 mm/s	
Ambient and fluid temperature	+5 to +60°C	
Stroke length tolerance	+1.4 0 mm	
Cushion	Rubber bumper (Standard equipment)	
Mounting	Basic, Axial foot, Rod flange, Head flange, Single clevis, Double clevis, Rod trunnion, Head trunnion, Integrated clevis, Integrated clevis (90°), Boss-cut	
Made to Order**	-XA <input type="checkbox"/>	Change of rod end shape
	-XC3 <input type="checkbox"/>	Special port location

* Auto switch can be mounted. Dimensions are the same as the standard type.

** For details, refer to pages 1703 to 1896.

Clean Series

10-CM2 **Mounting type** **Bore size** - **Stroke** **Z**

• Clean Series (With relief port)

The type which is applicable for using inside the clean room graded ISO Class 4 by making an actuator's rod section a double seal construction and discharging by relief port directly to the outside of clean room.



Specifications

Action	Double acting, Single rod
Bore size (mm)	ø20, ø25, ø32, ø40
Max. operating pressure	1.0 MPa
Min. operating pressure	0.05 MPa
Cushion	Rubber bumper, Air cushion
Relief port size	M5 x 0.8
Piston speed	30 to 400 mm/s
Mounting	Basic, Axial foot, Rod flange, Head flange, Boss-cut

* Auto switch can be mounted.

For detailed specifications about the clean series, refer to the "Pneumatic Clean Series" (CAT.E02-23).

Construction

ø20, ø25

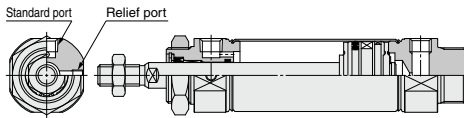

ø32, ø40

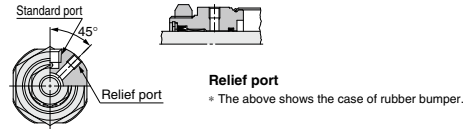

Water Resistant

CDM2 **Mounting type** **Bore size** **Port thread type** **R** - **Stroke** **A** **Z** - **M9BA** **XC6**

• With auto switch (Built-in magnet)

Water resistant cylinder	
R	NBR seals (Nitrile rubber)
V	FKM seals (Fluororubber)

Cushion

Nil	Rubber bumper
A	Air cushion

• Made to Order

• Water resistant 2-color indicator, solid state auto switch

Ideal for use in a machine tool environment exposed to coolant mist.

Also, applicable for use in an environment with water splashing such as food processing and car wash equipment, etc.



Dimensions (Dimensions other than below are the same as standard type.)

Male rod end

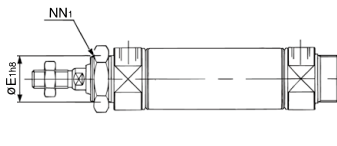

Female rod end

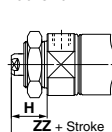

Bore size (mm)	E ₁	NN ₁	H	ZZ
20	22 ^{+0.033} _{-0.033}	M22 x 1.5	24	99
25	*26 ^{+0.033} _{-0.033}	*M26 x 1.5	24	99
32	*26 ^{+0.033} _{-0.033}	*M26 x 1.5	24	101
40	*32 ^{+0.039} _{-0.039}	*M32 x 2	26	130

※: Same as the standard type.

Specifications

Action	Double acting, Single rod
Bore size (mm)	ø20, ø25, ø32, ø40
Cushion	Rubber bumper, Air cushion
Auto switch mounting	Band mounting type
Made to Order	XC6: Made of stainless steel

* Specifications other than the above are the same as the standard type.
 * D-A3□A/A44A/G39A/K39A/B54/B64 cannot be mounted on bore sizes ø20 and ø25 cylinder with air cushion.

Mounting Brackets* / Part No.

Mounting bracket	Min. order qty	Bore size (mm)	
		20	Contents (for minimum order quantity)
Axial foot**	2	CM-L020C	2 feets, 1 mounting nut
Flange	1	CM-F020C	1 flange
Trunnion (with nut)	1	CM-T020C	1 trunnion, 1 trunnion nut

* ø25 to ø40: Same as the standard type.

** Order 2 feets per cylinder.

⚠ Caution

Rod seal and scraper are not replaceable.

• Scraper is press-fit into the rod cover, thus cannot be replaced.

CJ1

CJP

CJ2

JCM

CM2

CM3

CG1

CG3

JMB

MB

MB1

CA2

CS1

CS2

D-□

-X□

Technical Data

CM2 Series

Low Speed Cylinder

CM2 X Mounting type Bore size – Stroke Z
 ↓
 Low Speed Cylinder

Smooth operation with a little sticking and slipping at low speed. Can start smoothly with a little ejection even after being rendered for hours.



Specifications

Bore size (mm)	20, 25, 32, 40
Type	Pneumatic
Action	Double acting, Single rod
Fluid	Air
Proof pressure	1.5 MPa
Max. operating pressure	1.0 MPa
Min. operating pressure	0.025 MPa
Ambient and fluid temperature	Without auto switch: -10 to 70°C With auto switch: -10 to 60°C (No freezing)
Cushion	Rubber bumper

Dimensions: Same as standard type

For details, refer to the Best Pneumatics No. 2-3.

Piston Speed

Bore size (mm)	20	25	32	40	
Piston speed (mm/s)	0.5 to 300				
Allowable kinetic energy (J)	Male thread	0.27	0.4	0.65	1.2
	Female thread	0.11	0.18	0.29	0.52

Cylinder with Stable Lubrication Function (Lube-retainer)

CDM2 Mounting Bore size M – Stroke Rod end thread Z – Pivot bracket Rod end bracket – Auto switch

• With auto switch (Built-in magnet) • Cylinder with Stable Lubrication Function (Lube-retainer)

* D: Available only for with auto switch.



Specifications

Bore size (mm)	20, 25, 32, 40
Action	Double acting, Single rod
Min. operating pressure	0.1 MPa
Piston speed	50 to 750 mm/s
Cushion	Rubber bumper

* Specifications other than the above are the same as the standard type.

Dimensions: Same as standard type

For details, refer to the Web Catalog.

Construction

Rubber bumper

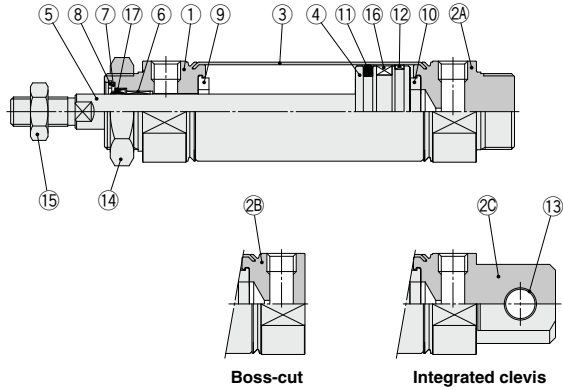

Air-hydro

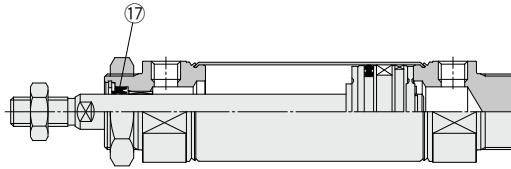

With air cushion

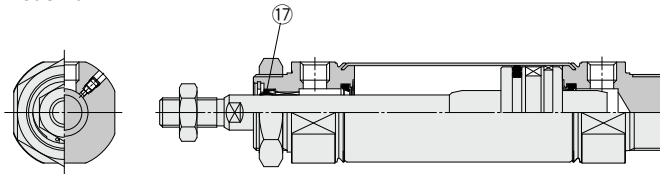

Component Parts

No.	Description	Material	Note
1	Rod cover	Aluminum alloy	Anodized
2A	Head cover A	Aluminum alloy	Anodized
2B	Head cover B	Aluminum alloy	Anodized
2C	Head cover C	Aluminum alloy	Anodized
3	Cylinder tube	Stainless steel	
4	Piston	Aluminum alloy	
5	Piston rod	Carbon steel	Hard chrome plating
6	Bushing	Bearing alloy	
7	Seal retainer	Stainless steel	
8	Retaining ring	Carbon steel	Phosphate coating
9	Bumper	Resin	ø25 or larger is common.
10	Bumper	Resin	
11	Piston seal	NBR	

No.	Description	Material	Note
12	Wear ring	Resin	
13	Clevis bushing	Bearing alloy	
14	Mounting nut	Carbon steel	Nickel plating
15	Rod end nut	Carbon steel	Zinc chromated
16	Magnet	—	CDM2□20 to 40-□Z
17	Rod seal	NBR	

Replacement Part: Seal

●With Rubber Bumper/With Air Cushion

No.	Description	Material	Part no.			
			20	25	32	40
17	Rod seal	NBR	CM20Z-PS	CM25Z-PS	CM32Z-PS	CM40Z-PS

●Air-hydro

17	Rod seal	NBR	CM2H20-PS	CM2H25-PS	CM2H32-PS	CM2H40-PS
----	----------	-----	-----------	-----------	-----------	-----------

* Since the seal does not include a grease pack, order it separately.
Grease pack part number: GR-S-010 (10 g)

CJ1
CJP
CJ2
JCM
CM2
CM3
CG1
CG3
JMB
MB
MB1
CA2
CS1
CS2

D-□
-X□
Technical Data

CM2 Series

Basic (Double-side Bossed) (B)

CM2B –

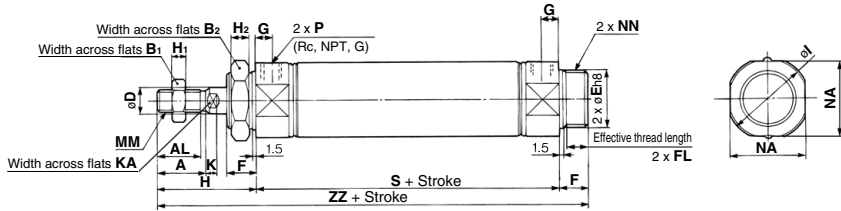

With rod boot

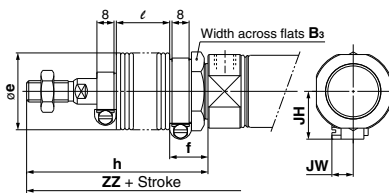

With air cushion

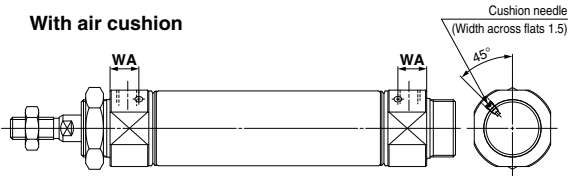

Boss-cut

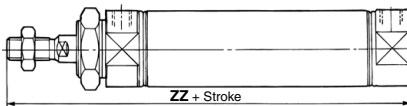

Female rod end

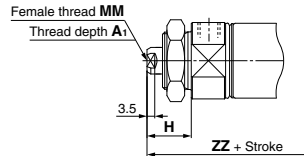

Bore size	A	AL	B ₁	B ₂	D	E	F	FL	G	H	H ₁	H ₂	I	K	KA	MM	NA	NN	P	S	ZZ
20	18	15.5	13	26	8	20 _{0.033}	13	10.5	8	41	5	8	28	5	6	M8 x 1.25	24	M20 x 1.5	1/8	62	116
25	22	19.5	17	32	10	26 _{0.033}	13	10.5	8	45	6	8	33.5	5.5	8	M10 x 1.25	30	M26 x 1.5	1/8	62	120
32	22	19.5	17	32	12	26 _{0.033}	13	10.5	8	45	6	8	37.5	5.5	10	M10 x 1.25	34.5	M26 x 1.5	1/8	64	122
40	24	21	22	41	14	32 _{0.039}	16	13.5	11	50	8	10	46.5	7	12	M14 x 1.5	42.5	M32 x 2	1/4	88	154

With Rod Boot

Bore size	Symbol	Stroke	B _s	e	f	h																l																ZZ															
						1 to 50	51 to 100	101 to 150	151 to 200	201 to 300	301 to 400	401 to 500	1 to 50	51 to 100	101 to 150	151 to 200	201 to 300	301 to 400	401 to 500	1 to 50	51 to 100	101 to 150	151 to 200	201 to 300	301 to 400	401 to 500																											
20			30	36	18	68	81	93	106	131	156	181	12.5	25	37.5	50	75	100	125	143	156	168	181	206	231	256																											
25			32	36	18	72	85	97	110	135	160	185	12.5	25	37.5	50	75	100	125	147	160	172	185	210	235	260																											
32			32	36	18	72	85	97	110	135	160	185	12.5	25	37.5	50	75	100	125	149	162	174	187	212	237	262																											
40			41	46	20	77	90	102	115	140	165	190	12.5	25	37.5	50	75	100	125	181	194	206	219	244	269	294																											

With Rod Boot (mm)

Bore size	JH	JW
20	23.5	10.5
25	23.5	10.5
32	23.5	10.5
40	27	10.5

Boss-cut (mm)

Bore size	ZZ															
	Without rod boot	With rod boot														
20	103	130	143	155	168	193	218	243								
		107	134	147	159	172	197	222	247							
25	109	136	149	161	174	199	224	249								
		138	165	178	190	203	228	253	278							

Female Rod End (mm)

Bore size	A ₁	H	MM	ZZ
20	8	20	M4 x 0.7	95
25	8	20	M5 x 0.8	95
32	12	20	M6 x 1	97
40	13	21	M8 x 1.25	125

* When female thread is used, use a thin wrench when tightening the piston rod.

* When female thread is used, use a washer etc. to prevent the contact part at the rod end from being deformed depending on the material of the workpiece.

With Air Cushion (mm)

Bore size	WA
20	12
25	12
32	11
40	16

Axial Foot (L)

CM2L Bore size - Stroke Z

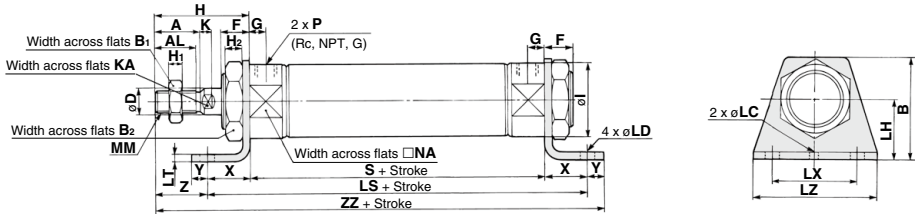

With rod boot

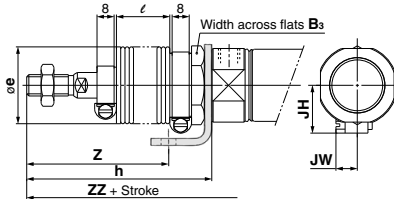

With air cushion

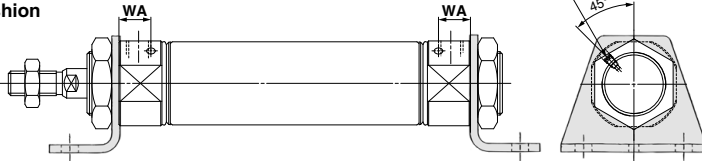

Female rod end

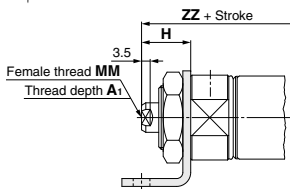

(mm)

Bore size	A	AL	B	B ₁	B ₂	D	F	G	H	H ₁	H ₂	I	K	KA	LC	LD	LH	LS	LT	LX	LZ	MM	NA	P	S	X	Y	Z	ZZ
20	18	15.5	40	13	26	8	13	8	41	5	8	28	5	6	4	6.8	25	102	3.2	40	55	M8 x 1.25	24	1/8	62	20	8	21	131
25	22	19.5	47	17	32	10	13	8	45	6	8	33.5	5.5	8	4	6.8	28	102	3.2	40	55	M10 x 1.25	30	1/8	62	20	8	25	135
32	22	19.5	47	17	32	12	13	8	45	6	8	37.5	5.5	10	4	6.8	28	104	3.2	40	55	M10 x 1.25	34.5	1/8	64	20	8	25	137
40	24	21	54	22	41	14	16	11	50	8	10	46.5	7	12	4	7	30	134	3.2	55	75	M14 x 1.5	42.5	1/4	88	23	10	27	171

With Rod Boot

(mm)

Symbol Stroke	B ₃	e	h										l						Z					
			1 to 50	51 to 100	101 to 150	151 to 200	201 to 300	301 to 400	401 to 500	1 to 50	51 to 100	101 to 150	151 to 200	201 to 300	301 to 400	401 to 500	1 to 50	51 to 100	101 to 150	151 to 200	201 to 300	301 to 400	401 to 500	
20	30	36	68	81	93	106	131	156	181	12.5	25	37.5	50	75	100	125	48	61	73	86	111	136	161	
25	32	36	72	85	97	110	135	160	185	12.5	25	37.5	50	75	100	125	52	65	77	90	115	140	165	
32	32	36	72	85	97	110	135	160	185	12.5	25	37.5	50	75	100	125	52	65	77	90	115	140	165	
40	41	46	77	90	102	115	140	165	190	12.5	25	37.5	50	75	100	125	54	67	79	92	117	142	167	

With Rod Boot

(mm)

Symbol Stroke	ZZ								JH	JW
	1 to 50	51 to 100	101 to 150	151 to 200	201 to 300	301 to 400	401 to 500			
20	158	171	183	196	221	246	271	23.5	10.5	
25	162	175	187	200	225	250	275	23.5	10.5	
32	164	177	189	202	227	252	277	23.5	10.5	
40	198	211	223	236	261	286	311	27	10.5	

With Air Cushion

(mm)

Bore size	WA
20	12
25	12
32	11
40	16

Female Rod End

(mm)

Bore size	A ₁	H	MM	ZZ
20	8	20	M4 x 0.7	110
25	8	20	M5 x 0.8	110
32	12	20	M6 x 1	112
40	13	21	M8 x 1.25	142

* When female thread is used, use a thin wrench when tightening the piston rod.

* When female thread is used, use a washer etc. to prevent the contact part at the rod end from being deformed depending on the material of the workpiece.

* The bracket is shipped together.

- CJ1
- CJP
- CJ2
- JCM
- CM2
- CM3
- CG1
- CG3
- JMB
- MB
- MB1
- CA2
- CS1
- CS2

- D-
- X

Technical Data

CM2 Series

Rod Flange (F)

CM2F -

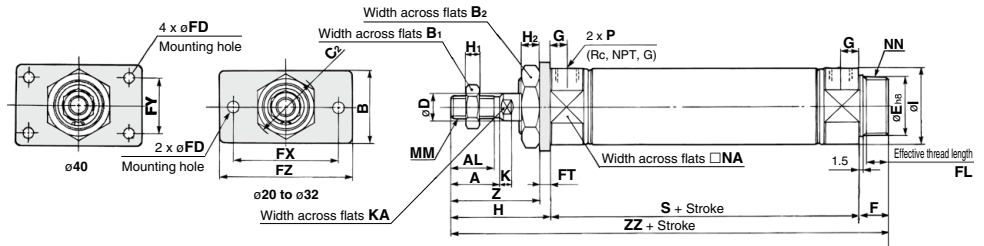

With rod boot

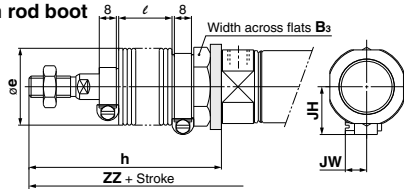

Boss-cut

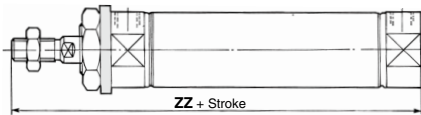

With air cushion

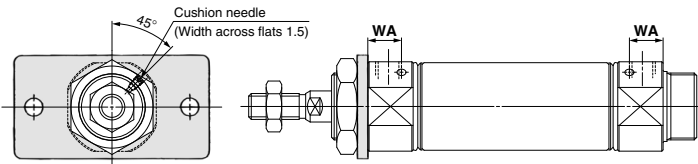

Female rod end

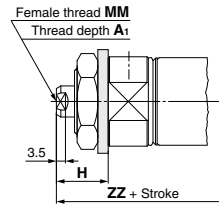

																				(mm)									
Bore size	A	AL	B	B ₁	B ₂	C ₂	D	E	F	FL	FD	FT	FX	FY	FZ	G	H	H ₁	H ₂	I	K	KA	MM	NA	NN	P	S	Z	ZZ
20	18	15.5	34	13	26	30	8	20 ^{0.033}	13	10.5	7	4	60	—	75	8	41	5	8	28	5	6	M8 x 1.25	24	M20 x 1.5	1/8	62	37	116
25	22	19.5	40	17	32	37	10	26 ^{0.033}	13	10.5	7	4	60	—	75	8	45	6	8	33.5	5.5	8	M10 x 1.25	30	M26 x 1.5	1/8	62	41	120
32	22	19.5	40	17	32	37	12	26 ^{0.033}	13	10.5	7	4	60	—	75	8	45	6	8	37.5	5.5	10	M10 x 1.25	34.5	M26 x 1.5	1/8	64	41	122
40	24	21	52	22	41	47.3	14	32 ^{0.033}	16	13.5	7	5	66	36	82	11	50	8	10	46.5	7	12	M14 x 1.5	42.5	M32 x 2	1/4	88	45	154

With Rod Boot

Symbol																						(mm)					
Bore size	Stroke	h										ℓ										ZZ					
		B ₃	e	1 to 50	51 to 100	101 to 150	151 to 200	201 to 300	301 to 400	401 to 500	1 to 50	51 to 100	101 to 150	151 to 200	201 to 300	301 to 400	401 to 500	1 to 50	51 to 100	101 to 150	151 to 200	201 to 300	301 to 400	401 to 500			
20	30	36	68	81	93	106	131	156	181	12.5	25	37.5	50	75	100	125	143	156	168	181	206	231	256				
25	32	36	72	85	97	110	135	160	185	12.5	25	37.5	50	75	100	125	147	160	172	185	210	235	260				
32	32	36	72	85	97	110	135	160	185	12.5	25	37.5	50	75	100	125	149	162	174	187	212	237	262				
40	41	46	77	90	102	115	140	165	190	12.5	25	37.5	50	75	100	125	181	194	206	219	244	269	294				

With Rod Boot (mm)

Bore size	JH	JW
20	23.5	10.5
25	23.5	10.5
32	23.5	10.5
40	27	10.5

Boss-cut (mm)

Bore size	ZZ									
	Without rod boot		With rod boot							
	1 to 50	51 to 100	101 to 150	151 to 200	201 to 300	301 to 400	401 to 500			
20	103	130	143	155	168	193	218	243		
25	107	134	147	159	172	197	222	247		
32	109	136	149	161	174	199	224	249		
40	138	165	178	190	203	228	253	278		

Female Rod End (mm)

Bore size	A ₁	H	MM	ZZ
20	8	20	M4 x 0.7	95
25	8	20	M5 x 0.8	95
32	12	20	M6 x 1	97
40	13	21	M8 x 1.25	125

* When female thread is used, use a thin wrench when tightening the piston rod.

* When female thread is used, use a washer etc. to prevent the contact part at the rod end from being deformed depending on the material of the workpiece.

With Air Cushion (mm)

Bore size	WA
20	12
25	12
32	11
40	16

* The bracket is shipped together.

Head Flange (G)

CM2G Bore size – Stroke Z

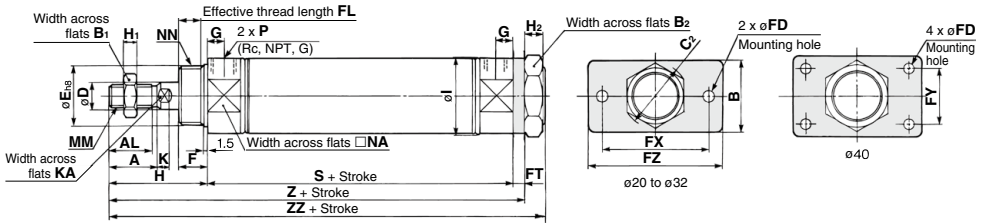

With rod boot

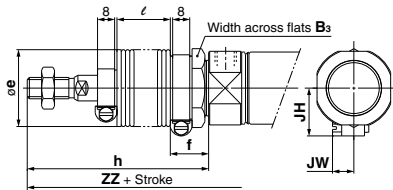

With air cushion

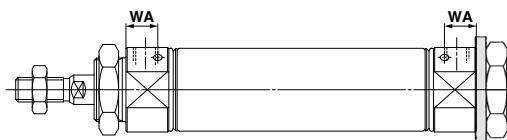

Cushion needle
(Width across flats 1.5)

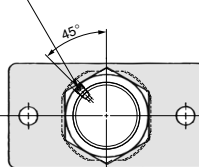

Female rod end

Female thread MM
Thread depth A1

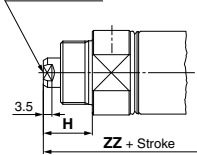

Bore size	A	AL	B	B ₁	B ₂	C ₂	D	E	F	FL	FD	FT	FX	FY	FZ	G	H	H ₁	H ₂	I
20	18	15.5	34	13	26	30	8	20 ^{±0.033}	13	10.5	7	4	60	—	75	8	41	5	8	28
25	22	19.5	40	17	32	37	10	26 ^{±0.033}	13	10.5	7	4	60	—	75	8	45	6	8	33.5
32	22	19.5	40	17	32	37	12	26 ^{±0.033}	13	10.5	7	4	60	—	75	8	45	6	8	37.5
40	24	21	52	22	41	47.3	14	32 ^{±0.039}	16	13.5	7	5	66	36	82	11	50	8	10	46.5

Bore size	K	KA	MM	NA	NN	P	S	Z	ZZ
20	5	6	M8 x 1.25	24	M20 x 1.5	1/8	62	107	116
25	5.5	8	M10 x 1.25	30	M26 x 1.5	1/8	62	111	120
32	5.5	10	M10 x 1.25	34.5	M26 x 1.5	1/8	64	113	122
40	7	12	M14 x 1.5	42.5	M32 x 2	1/4	88	143	154

With Rod Boot

Bore size	Symbol Stroke	B ₃	e	f	h																l																ZZ															
					1 to 50	51 to 100	101 to 150	151 to 200	201 to 300	301 to 400	401 to 500	1 to 50	51 to 100	101 to 150	151 to 200	201 to 300	301 to 400	401 to 500	1 to 50	51 to 100	101 to 150	151 to 200	201 to 300	301 to 400	401 to 500																											
20	30	36	18	68	81	93	106	131	156	181	12.5	25	37.5	50	75	100	125	143	156	168	181	206	231	256																												
25	32	36	18	72	85	97	110	135	160	185	12.5	25	37.5	50	75	100	125	147	160	172	185	210	235	260																												
32	32	36	18	72	85	97	110	135	160	185	12.5	25	37.5	50	75	100	125	149	162	174	187	212	237	262																												
40	41	46	20	77	90	102	115	140	165	190	12.5	25	37.5	50	75	100	125	181	194	206	219	244	269	294																												

With Rod Boot (mm)

Bore size	JH	JW
20	23.5	10.5
25	23.5	10.5
32	23.5	10.5
40	27	10.5

With Air Cushion (mm)

Bore size	WA
20	12
25	12
32	11
40	16

Female Rod End (mm)

Bore size	A ₁	H	MM	ZZ
20	8	20	M4 x 0.7	95
25	8	20	M5 x 0.8	95
32	12	20	M6 x 1	97
40	13	21	M8 x 1.25	125

* The bracket is shipped together.

- * When female thread is used, use a thin wrench when tightening the piston rod.
- * When female thread is used, use a washer etc. to prevent the contact part at the rod end from being deformed depending on the material of the workpiece.

- CJ1
- CJP
- CJ2
- JCM
- CM2
- CM3
- CG1
- CG3
- JMB
- MB
- MB1
- CA2
- CS1
- CS2

- D-□
- X□

Technical Data

CM2 Series

Single Clevis (C)

CM2C Bore size – Stroke Z

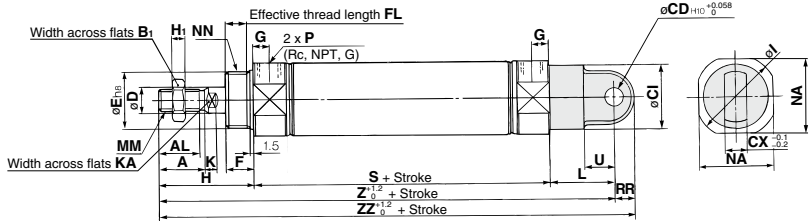

With rod boot

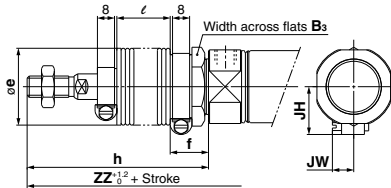

With air cushion

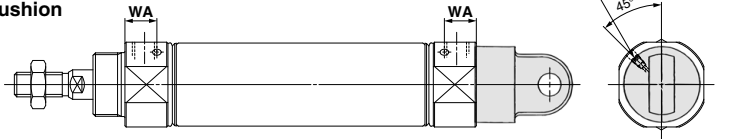

Female rod end

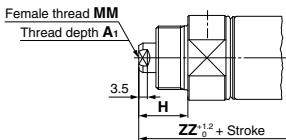

Bore size	A	AL	B ₁	Cl	CD	CX	D	E	F	FL	G	H	H ₁	I	K	KA	L	MM	NA	NN	P	RR	S	U	Z	ZZ
20	18	15.5	13	24	9	10	8	20 ^{0.033}	13	10.5	8	41	5	28	5	6	30	M8 x 1.25	24	M20 x 1.5	1/8	9	62	14	133	142
25	22	19.5	17	30	9	10	10	26 ^{0.033}	13	10.5	8	45	6	33.5	5.5	8	30	M10 x 1.25	30	M26 x 1.5	1/8	9	62	14	137	146
32	22	19.5	17	30	9	10	12	26 ^{0.033}	13	10.5	8	45	6	37.5	5.5	10	30	M10 x 1.25	34.5	M26 x 1.5	1/8	9	64	14	139	148
40	24	21	22	38	10	15	14	32 ^{0.039}	16	13.5	11	50	8	46.5	7	12	39	M14 x 1.5	42.5	M32 x 2	1/4	11	88	18	177	188

(mm)

With Rod Boot

Symbol Stroke	B ₃	e	f	h								l				Z								
				1 to 50	51 to 100	101 to 150	151 to 200	201 to 300	301 to 400	401 to 500	1 to 50	51 to 100	101 to 150	151 to 200	201 to 300	301 to 400	401 to 500	1 to 50	51 to 100	101 to 150	151 to 200	201 to 300	301 to 400	401 to 500
20	30	36	18	68	81	93	106	131	156	181	12.5	25	37.5	50	75	100	125	160	173	185	198	223	248	273
25	32	36	18	72	85	97	110	135	160	185	12.5	25	37.5	50	75	100	125	164	177	189	202	227	252	277
32	32	36	18	72	85	97	110	135	160	185	12.5	25	37.5	50	75	100	125	166	179	191	204	229	254	279
40	41	46	20	77	90	102	115	140	165	190	12.5	25	37.5	50	75	100	125	204	217	229	242	267	292	317

(mm)

With Rod Boot

Symbol Stroke	ZZ								JH	JW
	1 to 50	51 to 100	101 to 150	151 to 200	201 to 300	301 to 400	401 to 500			
20	169	182	194	207	232	257	282	23.5	10.5	
25	173	186	198	211	236	261	286	23.5	10.5	
32	175	188	200	213	238	263	288	23.5	10.5	
40	215	228	240	253	278	303	328	27	10.5	

With Air Cushion (mm)

Bore size	WA
20	12
25	12
32	11
40	16

Female Rod End (mm)

Bore size	A ₁	H	MM	ZZ
20	8	20	M4 x 0.7	121
25	8	20	M5 x 0.8	121
32	12	20	M6 x 1	123
40	13	21	M8 x 1.25	159

- * When female thread is used, use a thin wrench when tightening the piston rod.
- * When female thread is used, use a washer etc. to prevent the contact part at the rod end from being deformed depending on the material of the workpiece.

Double Clevis (D)

CM2D Bore size – Stroke Z

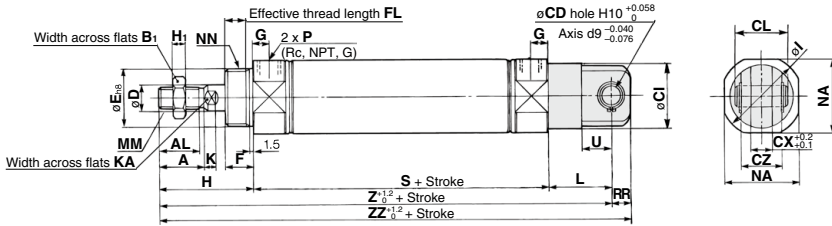

With rod boot

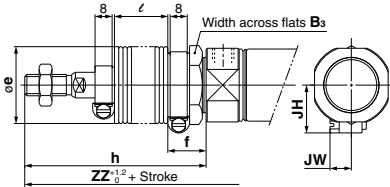

With air cushion

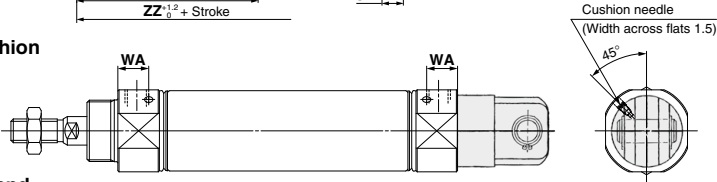

Female rod end

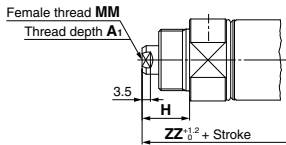

Bore size	A	AL	B ₁	CD	CL	CX	CZ	D	E	F	FL	G	H	H ₁	I	K	KA	L	MM	NA	NN	P	RR	S	U	Z	ZZ	
20	18	15.5	13	9	24	25	10	19	8	20 _{-0.033}	13	10.5	8	41	5	28	5	6	30	M8 x 1.25	24	M20 x 1.5	1/8	9	62	14	133	142
25	22	19.5	17	9	30	25	10	19	10	26 _{-0.033}	13	10.5	8	45	6	33.5	5.5	8	30	M10 x 1.25	30	M26 x 1.5	1/8	9	62	14	137	146
32	22	19.5	17	9	30	25	10	19	12	26 _{-0.033}	13	10.5	8	45	6	37.5	5.5	10	30	M10 x 1.25	34.5	M26 x 1.5	1/8	9	64	14	139	148
40	24	21	22	10	38	41.2	15	30	14	32 _{-0.038}	16	13.5	11	50	8	46.5	7	12	39	M14 x 1.5	42.5	M32 x 2	1/4	11	88	18	177	188

With Rod Boot

Bore size	Symbol Stroke	B ₃	e	f	h										l										Z									
					1 to 50	51 to 100	101 to 150	151 to 200	201 to 300	301 to 400	401 to 500	1 to 50	51 to 100	101 to 150	151 to 200	201 to 300	301 to 400	401 to 500	1 to 50	51 to 100	101 to 150	151 to 200	201 to 300	301 to 400	401 to 500									
20	30	36	18	68	81	93	106	131	156	181	12.5	25	37.5	50	75	100	125	160	173	185	198	223	248	273										
25	32	36	18	72	85	97	110	135	160	185	12.5	25	37.5	50	75	100	125	164	177	189	202	227	252	277										
32	32	36	18	72	85	97	110	135	160	185	12.5	25	37.5	50	75	100	125	166	179	191	204	229	254	279										
40	41	46	20	77	90	102	115	140	165	190	12.5	25	37.5	50	75	100	125	204	217	229	242	267	292	317										

With Rod Boot

Bore size	Symbol Stroke	ZZ						JH	JW
		1 to 50	51 to 100	101 to 150	151 to 200	201 to 300	301 to 400		
20	169	182	194	207	232	257	282	23.5	10.5
25	173	186	198	211	236	261	286	23.5	10.5
32	175	188	200	213	238	263	288	23.5	10.5
40	215	228	240	253	278	303	328	27	10.5

With Air Cushion (mm)

Bore size	WA
20	12
25	12
32	11
40	16

Female Rod End (mm)

Bore size	A ₁	H	MM	ZZ
20	8	20	M4 x 0.7	121
25	8	20	M5 x 0.8	121
32	12	20	M6 x 1	123
40	13	21	M8 x 1.25	159

- * When female thread is used, use a thin wrench when tightening the piston rod.
- * When female thread is used, use a washer etc. to prevent the contact part at the rod end from being deformed depending on the material of the workpiece.

- CJ1
- CJP
- CJ2
- JCM
- CM2
- CM3
- CG1
- CG3
- JMB
- MB
- MB1
- CA2
- CS1
- CS2

- D-
- X
- Technical Data

CM2 Series

Rod Trunnion (U)

CM2U | Bore size | – Stroke | Z

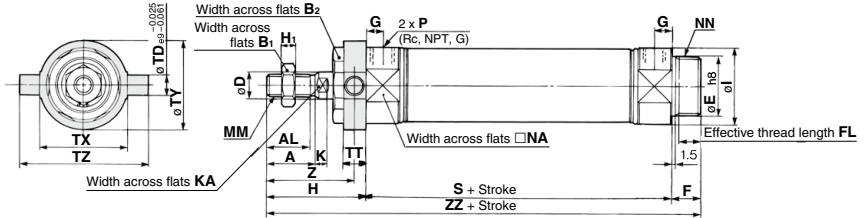

With rod boot

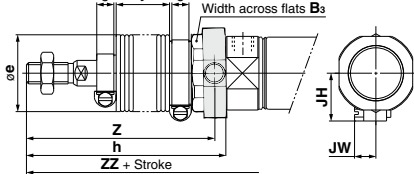

Boss-cut

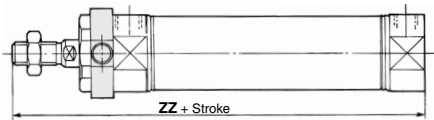

With air cushion

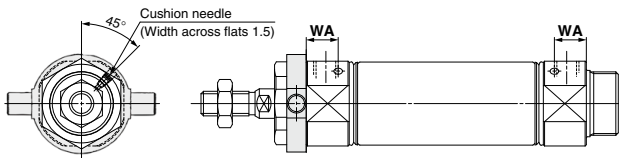

Female rod end

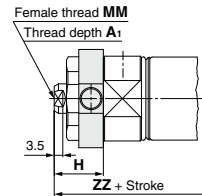

Bore size	A	AL	B ₁	B ₂	D	E	F	FL	G	H	H ₁	I	K	KA	MM	NA	NN	P
20	18	15.5	13	26	8	20 ⁰ _{0.033}	13	10.5	8	41	5	28	5	6	M8 x 1.25	24	M20 x 1.5	1/8
25	22	19.5	17	32	10	26 ⁰ _{0.033}	13	10.5	8	45	6	33.5	5.5	8	M10 x 1.25	30	M26 x 1.5	1/8
32	22	19.5	17	32	12	26 ⁰ _{0.033}	13	10.5	8	45	6	37.5	5.5	10	M10 x 1.25	34.5	M26 x 1.5	1/8
40	24	21	22	41	14	32 ⁰ _{0.039}	16	13.5	11	50	8	46.5	7	12	M14 x 1.5	42.5	M32 x 2	1/4

Bore size	S	TD	TT	TX	TY	TZ	Z	ZZ
20	62	8	10	32	32	52	36	116
25	62	9	10	40	40	60	40	120
32	64	9	10	40	40	60	40	122
40	88	10	11	53	53	77	44.5	154

With Rod Boot

Bore size	Symbol	Stroke	h								
			B ₃	e	1 to 50	51 to 100	101 to 150	151 to 200	201 to 300	301 to 400	401 to 500
20			30	36	68	81	93	106	131	156	181
25			32	36	72	85	97	110	135	160	185
32			32	36	72	85	97	110	135	160	185
40			41	46	77	90	102	115	140	165	190

With Rod Boot

Bore size	Symbol	Stroke	Z								ZZ								JH	JW					
			1 to 50	51 to 100	101 to 150	151 to 200	201 to 300	301 to 400	401 to 500	1 to 50	51 to 100	101 to 150	151 to 200	201 to 300	301 to 400	401 to 500									
20			12.5	25	37.5	50	75	100	125	63	76	88	101	126	151	176	143	156	168	181	206	231	256	23.5	10.5
25			12.5	25	37.5	50	75	100	125	67	80	92	105	130	155	180	147	160	172	185	210	235	260	23.5	10.5
32			12.5	25	37.5	50	75	100	125	67	80	92	105	130	155	180	149	162	174	187	212	237	262	23.5	10.5
40			12.5	25	37.5	50	75	100	125	71.5	84.5	96.5	109.5	134.5	159.5	184.5	181	194	206	219	244	269	294	27	10.5

Boss-cut

Bore size	ZZ							
	With rod boot							
	Without rod boot	1 to 50	51 to 100	101 to 150	151 to 200	201 to 300	301 to 400	401 to 500
20	103	130	143	155	168	193	218	243
25	107	134	147	159	172	197	222	247
32	109	136	149	161	174	199	224	249
40	138	165	178	190	203	228	253	278

With Air Cushion

Bore size	WA
20	12
25	12
32	11
40	16

Female Rod End

Bore size	A ₁	H	MM	ZZ
20	8	20	M4 x 0.7	95
25	8	20	M5 x 0.8	95
32	12	20	M6 x 1	97
40	13	21	M8 x 1.25	125

* The bracket is shipped together.

Head Trunnion (T)

CM2T -

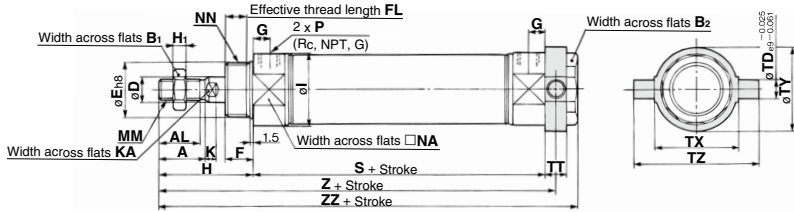

With rod boot

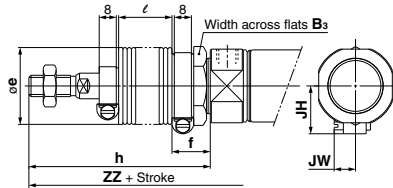

With air cushion

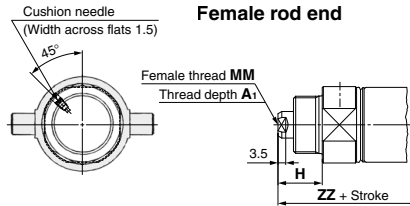
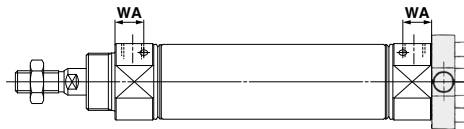

Bore size	A	AL	B ₁	B ₂	D	E	F	FL	G	H	H ₁	I	K	KA	MM	NA	NN	P
20	18	15.5	13	26	8	20 ^{±0.033}	13	10.5	8	41	5	28	5	6	M8 x 1.25	24	M20 x 1.5	1/8
25	22	19.5	17	32	10	26 ^{±0.033}	13	10.5	8	45	6	33.5	5.5	8	M10 x 1.25	30	M26 x 1.5	1/8
32	22	19.5	17	32	12	26 ^{±0.033}	13	10.5	8	45	6	37.5	5.5	10	M10 x 1.25	34.5	M26 x 1.5	1/8
40	24	21	22	41	14	32 ^{±0.039}	16	13.5	11	50	8	46.5	7	12	M14 x 1.5	42.5	M32 x 2	1/4

Bore size	S	TD	TT	TX	TY	TZ	Z	ZZ
20	62	8	10	32	32	52	108	118
25	62	9	10	40	40	60	112	122
32	64	9	10	40	40	60	114	124
40	88	10	11	53	53	77	143.5	154

Bore size	Symbol		h											
	B ₃	e	f	1 to 50	51 to 100	101 to 150	151 to 200	201 to 300	301 to 400	401 to 500				
20	30	36	18	68	81	93	106	131	156	181				
25	32	36	18	72	85	97	110	135	160	185				
32	32	36	18	72	85	97	110	135	160	185				
40	41	46	20	77	90	102	115	140	165	190				

With Rod Boot

Bore size	Symbol		h												JH	JW								
	Stroke	ℓ	Z	ZZ																				
20	1 to 50	51 to 100	101 to 150	151 to 200	201 to 300	301 to 400	401 to 500	1	50	100	150	151 to 200	201 to 300	301 to 400	401 to 500	1 to 50	51 to 100	101 to 150	151 to 200	201 to 300	301 to 400	401 to 500	23.5	10.5
25	12.5	25	37.5	50	75	100	125	135	148	160	173	198	223	248	145	158	170	183	208	233	258	23.5	10.5	
32	12.5	25	37.5	50	75	100	125	139	152	164	177	202	227	252	149	162	174	187	212	237	262	23.5	10.5	
40	12.5	25	37.5	50	75	100	125	141	154	166	179	204	229	254	151	164	176	189	214	239	264	23.5	10.5	

With Air Cushion (mm)

Bore size	WA
20	12
25	12
32	11
40	16

Female Rod End (mm)

Bore size	A ₁	H	MM	ZZ
20	8	20	M4 x 0.7	97
25	8	20	M5 x 0.8	97
32	12	20	M6 x 1	99
40	13	21	M8 x 1.25	125

* The bracket is shipped together.

* When female thread is used, use a thin wrench when tightening the piston rod.

* When female thread is used, use a washer etc. to prevent the contact part at the rod end from being deformed depending on the material of the workpiece.

- CJ1
- CJP
- CJ2
- JCM
- CM2
- CM3
- CG1
- CG3
- JMB
- MB
- MB1
- CA2
- CS1
- CS2

- D-□
- X□

Technical Data

CM2 Series

Integrated Clevis (E)

CM2E –

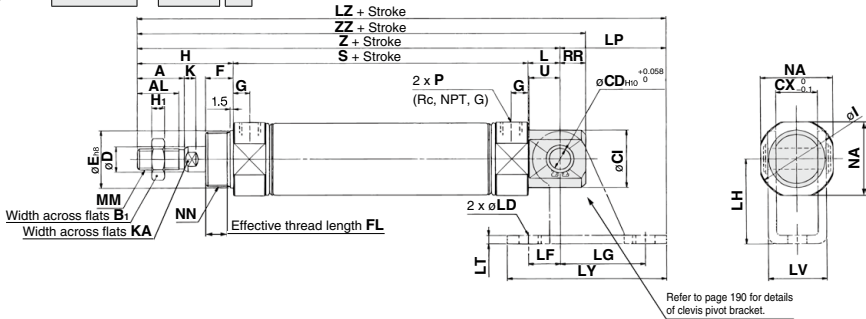

With rod boot

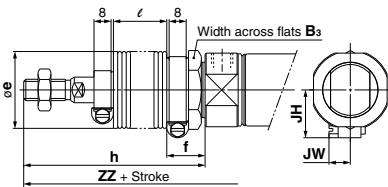

With air cushion

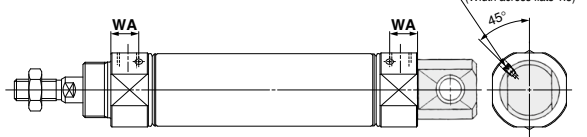

Integrated clevis (90°)(V)

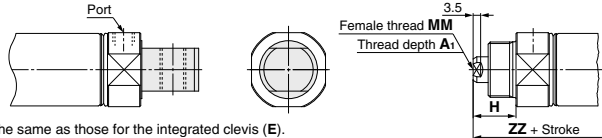

* The dimensions are the same as those for the integrated clevis (E).

Bore size	A	AL	B ₁	CD	CI	CX	D	E	F	FL	G	H	H ₁	I	K	KA	L	MM	NA	NN
20	18	15.5	13	8	20	12	8	20 _{0.033}	13	10.5	8	41	5	28	5	6	12	M8 x 1.25	24	M20 x 1.5
25	22	19.5	17	8	22	12	10	26 _{0.033}	13	10.5	8	45	6	33.5	5.5	8	12	M10 x 1.25	30	M26 x 1.5
32	22	19.5	17	10	27	20	12	26 _{0.033}	13	10.5	8	45	6	37.5	5.5	10	15	M10 x 1.25	34.5	M26 x 1.5
40	24	21	22	10	33	20	14	32 _{0.039}	16	13.5	11	50	8	46.5	7	12	15	M14 x 1.5	42.5	M32 x 2

Bore size	Symbol Stroke							With Air Cushion (mm)				With Rod Boot (mm)																																				
	A	AL	B ₁	CD	CI	CX	D	Bore size	WA	h																																						
20	1/8	9	62	11.5	115	124	20	12	20	12	13	14	15	16	17	18	19	20	21	22	23	24	25	26	27	28	29	30	31	32	33	34	35	36	37	38	39	40	41	42	43	44	45	46	47	48	49	50
25	1/8	9	62	11.5	119	128	25	12	25	12	13	14	15	16	17	18	19	20	21	22	23	24	25	26	27	28	29	30	31	32	33	34	35	36	37	38	39	40	41	42	43	44	45	46	47	48	49	50
32	1/8	12	64	14.5	124	136	32	11	32	11	13	14	15	16	17	18	19	20	21	22	23	24	25	26	27	28	29	30	31	32	33	34	35	36	37	38	39	40	41	42	43	44	45	46	47	48	49	50
40	1/4	12	88	14.5	153	165	40	16	40	16	13	14	15	16	17	18	19	20	21	22	23	24	25	26	27	28	29	30	31	32	33	34	35	36	37	38	39	40	41	42	43	44	45	46	47	48	49	50

With Rod Boot

Bore size	Symbol Stroke																Z		ZZ										JH	JW
	1 to 50	51 to 100	101 to 150	151 to 200	201 to 300	301 to 400	401 to 500	1 to 50	51 to 100	101 to 150	151 to 200	201 to 300	301 to 400	401 to 500	1 to 50	51 to 100	101 to 150	151 to 200	201 to 300	301 to 400	401 to 500									
20	12.5	25	37.5	50	75	100	125	142	155	167	180	205	230	255	151	164	176	189	214	239	264	23.5	10.5							
25	12.5	25	37.5	50	75	100	125	146	159	171	184	209	234	259	155	168	180	193	218	243	268	23.5	10.5							
32	12.5	25	37.5	50	75	100	125	151	164	176	189	214	239	264	163	176	188	201	226	251	276	23.5	10.5							
40	12.5	25	37.5	50	75	100	125	180	193	205	218	243	268	293	192	205	217	230	255	280	305	27	10.5							

Female Rod End

Bore size	A ₁	H	MM	ZZ
20	8	20	M4 x 0.7	103
25	8	20	M5 x 0.8	103
32	12	20	M6 x 1	111
40	13	21	M8 x 1.25	136

Clevis Pivot Bracket

Bore size	LD	LF	LG	LH	LP	LT	LV	LY	LZ
20	6.8	15	30	30	37	3.2	18.4	59	152
25	6.8	15	30	30	37	3.2	18.4	59	156
32	9	15	40	40	50	4	28	75	174
40	9	15	40	40	50	4	28	75	203

* When female thread is used, use a thin wrench when tightening the piston rod.
 * When female thread is used, use a washer etc. to prevent the contact part at the rod end from being deformed depending on the material of the workpiece.

CM2 Series

Dimensions of Accessories

With Single Knuckle Joint

(mm)

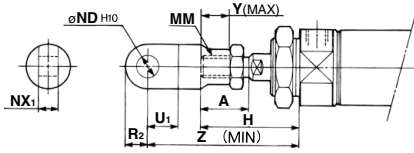

Bore size	A	H	MM	ND _{H10}	NX ₁	U ₁	R ₂	Y	Z
20	18	41	M8 x 1.25	9 ^{+0.058} ₀	9 ^{+0.1} _{-0.2}	14	10	11	66
25, 32	22	45	M10 x 1.25	9 ^{+0.058} ₀	9 ^{+0.1} _{-0.2}	14	10	14	69
40	24	50	M14 x 1.5	12 ^{+0.070} ₀	16 ^{+0.1} _{-0.3}	20	14	13	92

Single Knuckle Joint

(mm)

I-020B/032B Material: Carbon steel I-040B Material: Free-cutting steel

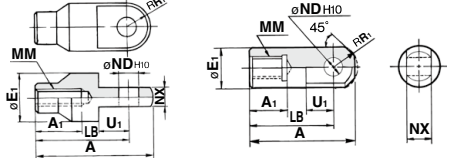

Part no.	Applicable bore size	A	A ₁	E ₁	LB	MM	ND _{H10}	NX	R ₁	U ₁
I-020B	20	46	16	20	36	M8 x 1.25	9 ^{+0.058} ₀	9 ^{+0.1} _{-0.2}	10	14
I-032B	25, 32	48	18	20	38	M10 x 1.25	9 ^{+0.058} ₀	9 ^{+0.1} _{-0.2}	10	14
I-040B	40	69	22	24	55	M14 x 1.5	12 ^{+0.070} ₀	16 ^{+0.1} _{-0.3}	15.5	20

With Double Knuckle Joint

(mm)

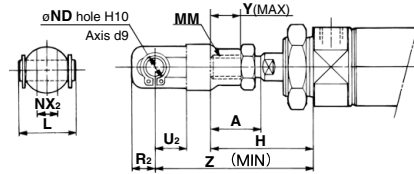

Bore size	A	H	L	MM	ND	NX ₂	R ₂	U ₂	Y	Z
20	18	41	25	M8 x 1.25	9	9 ^{+0.1} _{-0.2}	10	14	11	66
25, 32	22	45	25	M10 x 1.25	9	9 ^{+0.1} _{-0.2}	10	14	14	69
40	24	50	49.7	M14 x 1.5	12	16 ^{+0.1} _{-0.3}	13	25	13	92

Double Knuckle Joint

(mm)

Y-020B/032B Material: Carbon steel

Y-040B Material: Cast iron

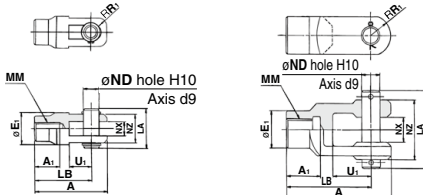

Part no.	Applicable bore size	A	A ₁	E ₁	LA	LB	MM	ND	NX	NZ	R ₁	U ₁	Included pin part number	Retaining ring Split pin size
Y-020B	20	46	16	20	25	36	M8 x 1.25	9	9 ^{+0.2} _{-0.3}	18	5	14	CDP-1	Type C 9 for axis
Y-032B	25, 32	48	18	20	25	38	M10 x 1.25	9	9 ^{+0.2} _{-0.3}	18	5	14	CDP-1	Type C 9 for axis
Y-040B	40	68	22	24	49.7	55	M14 x 1.5	12	16 ^{+0.3} _{-0.4}	38	13	25	CDP-3	ø3 x 18 L

* A knuckle pin and retaining rings (split pins for ø40) are included.

Double Clevis Pin/Material: Carbon steel

(mm)

Bore size: ø20, ø25, ø32

CDP-1

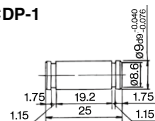

Retaining ring: Type C9 for axis

Bore size: ø40

CDP-2

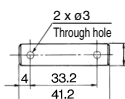

Split pin: ø3 x 18 L

* Retaining rings (split pins for ø40) are included.

Double Knuckle Pin/Material: Carbon steel

(mm)

Bore size: ø20, ø25, ø32

CDP-1

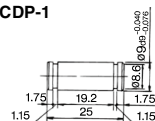

Retaining ring: Type C9 for axis

* Retaining rings (split pins for ø40) are included.

Bore size: ø40

CDP-3

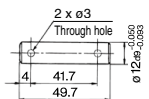

Split pin: ø3 x 18 L

CJ1

CJP

CJ2

JCM

CM2

CM3

CG1

CG3

JMB

MB

MB1

CA2

CS1

CS2

D-□

-X□

Technical Data

CM2 Series

Rod End Nut Material: Carbon steel (mm)

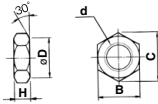

Part no.	Applicable bore size	B	C	D	d	H
NT-02	20	13	15.0	12.5	M8 x 1.25	5
NT-03	25, 32	17	19.6	16.5	M10 x 1.25	6
NT-04	40	22	25.4	21.0	M14 x 1.5	8

Mounting Nut Material: Carbon steel (mm)

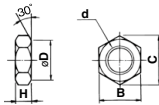

Part no.	Applicable bore size	B	C	D	d	H
SN-020B	20	26	30	25.5	M20 x 1.5	8
SN-032B	25, 32	32	37	31.5	M26 x 1.5	8
SN-040B	40	41	47.3	40.5	M32 x 2.0	10

Trunnion Nut Material: Carbon steel (mm)

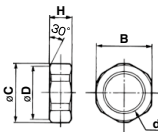

Part no.	Applicable bore size	B	C	D	d	H
TN-020B	20	26	28	25.5	M20 x 1.5	10
TN-032B	25, 32	32	34	31.5	M26 x 1.5	10
TN-040B	40	41	45	40.5	M32 x 2	10

Mounting Brackets, Rod End Brackets, and Nut Material: Stainless Steel

Part No. (Dimensions: Same as standard type)

Bore size (mm)	Foot	Flange	Single knuckle joint	Double knuckle joint*	Mounting nut	Rod end nut
20	CM-L020BSUS	CM-F020BSUS	I-020BSUS	Y-020BSUS	SN-020BSUS	NT-02SUS
25, 32	CM-L032BSUS	CM-F032BSUS	I-032BSUS	Y-032BSUS	SN-032BSUS	NT-03SUS
40	CM-L040BSUS	CM-F040BSUS	I-040BSUS	Y-040BSUS	SN-040BSUS	NT-04SUS

* A knuckle pin and retaining rings are shipped together. Refer to the XC27 for details on stainless steel double clevis pins and double knuckle pins. The accessories need to be ordered separately from the cylinder.

Clevis Pivot Bracket (For CM2E(V)) (mm)

Material: Carbon steel

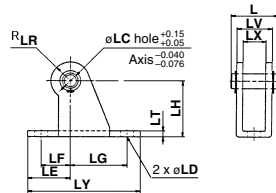

Part no.	Applicable bore size	L	LC	LD	LE	LF	LG	LH	LR
CM-E020B	20, 25	24.5	8	6.8	22	15	30	30	10
CM-E032B	32, 40	34	10	9	25	15	40	40	13

Part no.	Applicable bore size	LT	LX	LY	LV	Included pin part no.
CM-E020B	20, 25	3.2	12	59	18.4	CD-S02
CM-E032B	32, 40	4	20	75	28	CD-S03

Note 1) A clevis pivot bracket pin and retaining rings are included.
 Note 2) It cannot be used for the single clevis (CM2C) and the double clevis (CM2D).

Clevis Pivot Bracket Pin (For CM2E(V)) (mm)

Material: Carbon steel

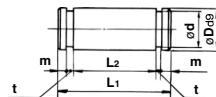

Part no.	Applicable bore size	Dd9	d	L1	L2	m	t	Included retaining ring
CD-S02	20, 25	8 ^{+0.040} / _{-0.076}	7.6	24.5	19.5	1.6	0.9	Type C 8 for axis
CD-S03	32, 40	10 ^{+0.040} / _{-0.076}	9.6	34	29	1.35	1.15	Type C 10 for axis

Note) Retaining rings are included.

With Single Clevis

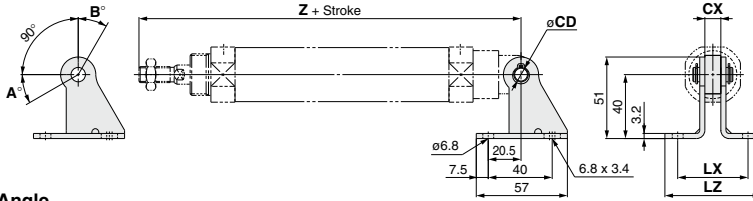

Rotation Angle

Bore size (mm)	A°	B°	A° + B° + 90°
20	25	85	200
25, 32	21	81	192
40	26	86	202

Mounting	Part no.	Applicable bore size	CX	Z + Stroke	CD	LX	LZ
CM2C (Single clevis)	CM-B032	20	10	133	9	44	60
		25		137			
		32		139			
	CM-B040	40	15	177	10	49	65

Note) A pivot bracket pin and retaining rings are not included with the pivot bracket.

With Rod Trunnion

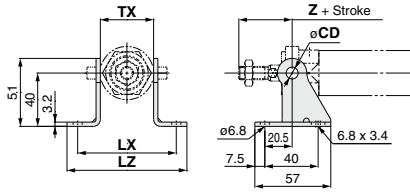

With Head Trunnion

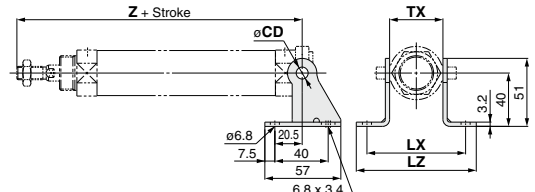

Mounting	Part no.	Applicable bore size	TX	Rod trunnion	Head trunnion	CD	LX	LZ
				Z + Stroke	Z + Stroke			
CM2U/CM2T (Rod/Head trunnion)	CM-B020	20	32	36	108	8	66	82
	CM-B032	25	40	40	112	9	74	90
		32			114			
	CM-B040	40	53	44.5	143.5	10	87	103

Note) A pivot bracket pin and retaining rings are not included with the pivot bracket.

Pivot Bracket

* Pivot brackets consists of a set of two brackets.

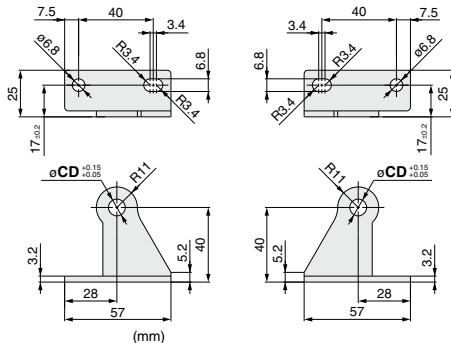

Part no.	CD
CM-B020 (Note 2)	8
CM-B032	9
CM-B040	10

Note 1) A pivot bracket pin and retaining rings are not included with the pivot bracket.
Note 2) Only for the trunnion

Pivot Bracket Pin (For CM2C)

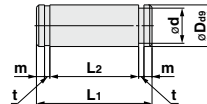

Applicable bore size	Part no.	D ₉₉	d	L ₁	L ₂	m	t	Included retaining ring
20 to 32	CDP-1	9 ^{+0.040} _{-0.078}	8.6	25	19.2	1.75	1.15	Type C 9 for axis
40	CD-S03	10 ^{+0.040} _{-0.078}	9.6	34	29	1.35	1.15	Type C 10 for axis

Note) Retaining rings are included with the pivot bracket pin.

CG1

CGP

CG2

CGM

CG2

CG3

CG1

CG3

JMB

MB

MB1

CA2

CS1

CS2

D-□

-X□

Technical Data

CM2 Series Auto Switch Mounting

Auto Switch Proper Mounting Position (Detection at stroke end) and Its Mounting Height

Solid state auto switch

- D-M9□
- D-M9□W
- D-M9□A

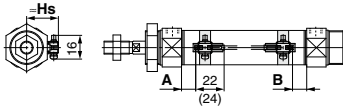

(): Values for D-M9□A
A and B are the dimensions from the end of the head cover/rod cover to the end of the auto switch.

- D-M9□V
- D-M9□WV
- D-M9□AV

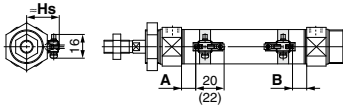

(): Values for D-M9□AV
A and B are the dimensions from the end of the head cover/rod cover to the end of the auto switch.

D-H7□/H7□W/H7NF/H7BA/H7C

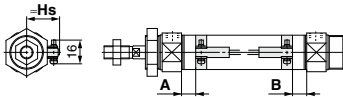

D-G5NT

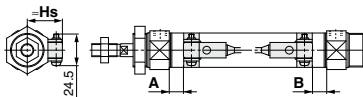

D-G39A/K39A

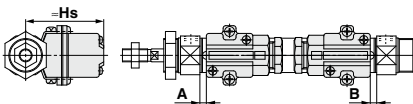

Reed auto switch

- D-A9□

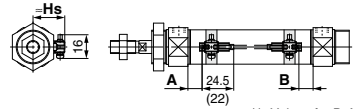

(): Values for D-A96
A and B are the dimensions from the end of the head cover/rod cover to the end of the auto switch.

- D-A9□V

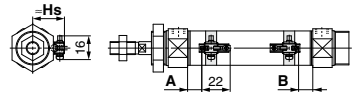

A and B are the dimensions from the end of the head cover/rod cover to the end of the auto switch.

D-C7/C8/C73C/C80C

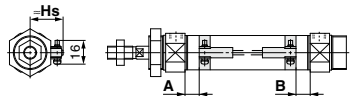

D-B5/B6/B59W

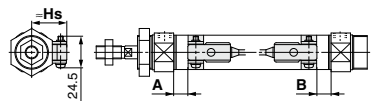

D-A33A/A34A

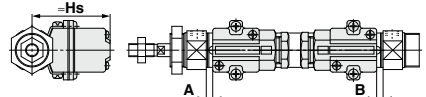

D-A44A

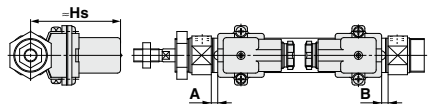

Auto Switch Proper Mounting Position (Detection at stroke end) and Its Mounting Height

Auto Switch Proper Mounting Position

(Standard type (except single acting type), Non-rotating rod type, Direct mount type, Direct mount, Non-rotating rod type (except single acting type)) (mm)

Auto switch model	D-M9□(V) D-M9□W(V) D-M9□A(V)		D-A9□(V)		D-G39A D-K39A D-A3□A D-A44A		D-H7□ D-H7C D-H7□W D-H7BA D-H7NF		D-G5NT		D-C7/C8 D-C73C D-C80C		D-B5□ D-B64		D-B59W	
	A	B	A	B	A	B	A	B	A	B	A	B	A	B	A	B
20	11	9.5	7	5.5	1	0	6.5	5	3	1.5	7.5	6	1.5	0	4	3
25	10	10	6	6	0	0	5.5	5.5	2	2	6.5	6.5	0.5	0.5	3.5	3.5
32	11.5	10.5	7.5	6.5	1.5	0.5	7	6	3.5	2.5	8	7	2	1	5	4
40	17.5	15.5	13.5	11.5	7.5	5.5	13	11	9.5	7.5	14	12	8	6	11	9

Note) Adjust the auto switch after confirming the operating condition in the actual setting.

Auto Switch Proper Mounting Position (Centralized piping type, With end lock)

CG1
CJP
CJ2
JCM
CM2
CM3
CG1
CG3
JMB
MB
MB1
CA2
CS1
CS2

(mm)

Auto switch model	D-M9□(V) D-M9□W(V) D-M9□A(V)		D-A9□(V)		D-G39A D-K39A D-A3□A D-A44A		D-H7□ D-H7C D-H7□W D-H7BA D-H7NF		D-G5NT		D-B5□ D-B64		D-C7□ D-C80 D-C73C D-C80C		D-B59W	
	A	B	A	B	A	B	A	B	A	B	A	B	A	B	A	B
20	10.5 (8)	9.5 (7)	6.5 (4)	5.5 (3)	0.5 (—)	0 (—)	6 (4)	5 (3)	2.5 (0.5)	1.5 (0)	1 (—)	0 (—)	7 (5)	6 (4)	4 (2)	3 (1)
25	10.5 (8)	9.5 (7)	6.5 (4)	5.5 (3)	0.5 (—)	0 (—)	6 (4)	5 (3)	2.5 (0.5)	1.5 (0)	1 (—)	0 (—)	7 (5)	6 (4)	4 (2)	3 (1)
32	11.5 (9)	10.5 (8)	7.5 (5)	6.5 (4)	1.5 (0)	0.5 (0)	7 (5)	6 (4)	3.5 (1.5)	2.5 (0.5)	2 (0)	1 (0)	8 (6)	7 (5)	5 (3)	4 (2)
40	17.5	15.5	13.5	11.5	6.5	5.5	12	11	8.5	7.5	7	6	13	12	10	9

* () : Setting position for the auto switch with an air cushion.

The D-B5/B6/A3□A/A44A/G39A/K39A cannot be mounted on the bore size ø20 and ø25 cylinder with an air cushion.

Note 1) Adjust the auto switch after confirming the operating condition in the actual setting.

Note 2) The D-A3□A/A44A/G39A/K39A cannot be mounted on the centralized piping type CDM2□P series.

Auto Switch Mounting Height

(mm)

Auto switch model	D-A9□(V) D-M9□(V) D-M9□W(V) D-M9□A(V)		D-B5□ D-B64 D-B59W D-G5NT D-H7C		D-C73C D-C80C		D-G39A D-K39A D-A3□A		D-A44A	
	Hs	Hs	Hs	Hs	Hs	Hs				
20	24.5	25.5	25	60	69.5					
25	27	28	27.5	62.5	72					
32	30.5	31.5	31	66	75.5					
40	34.5	35.5	35	70	79.5					

D-□
-X□
Technical Data

CM2 Series

Auto Switch Proper Mounting Position (Detection at stroke end) Single Acting/Spring Return Type (S), Spring Extend Type (T)

Standard Type/Spring Return Type (S)

Non-rotating Rod Type/Spring Return Type (S)

(mm)

Auto switch model	Bore size	A dimensions					B
		Up to 50 st	51 to 100 st	101 to 150 st	151 to 200 st	201 to 250 st	
D-M9□(V) D-M9□W(V) D-M9□A(V)	20	36	61	86	—	—	9.5
	25	35	60	85	—	—	10
	32	36.5	61.5	86.5	111.5	—	10.5
	40	42.5	67.5	92.5	117.5	142.5	15.5
D-A9□(V)	20	32	57	82	—	—	5.5
	25	31	56	81	—	—	6
	32	32.5	57.5	82.5	107.5	—	6.5
	40	38.5	63.5	88.5	113.5	138.5	11.5
D-H7□ D-H7C D-H7□W D-H7BA D-H7NF	20	31.5	56.5	81.5	—	—	5
	25	30.5	55.5	80.5	—	—	5.5
	32	32	57	82	107	—	6
	40	38	63	88	113	138	11
D-G5NT	20	28	53	78	—	—	1.5
	25	27	52	77	—	—	2
	32	28.5	53.5	78.5	103.5	—	2.5
	40	34.5	59.5	84.5	109.5	134.5	7.5
D-B5□ D-B64	20	26.5	51.5	76.5	—	—	0
	25	25.5	50.5	75.5	—	—	0.5
	32	27	52	77	102	—	1
	40	33	58	83	108	133	6
D-C7□ D-C80 D-C73C D-C80C	20	32.5	57.5	82.5	—	—	6
	25	31.5	56.5	81.5	—	—	6.5
	32	33	58	83	108	—	7
	40	39	64	89	114	139	12
D-B59W	20	29	54	79	—	—	2.5
	25	28.5	53.5	78.5	—	—	3.5
	32	30	55	80	105	—	4
	40	36	61	86	111	136	9
D-G39A D-K39A D-A3□A D-A44A	20	26	51	76	—	—	0
	25	25	50	75	—	—	0
	32	26.5	51.5	76.5	101.5	—	0.5
	40	32.5	57.5	82.5	107.5	132.5	5.5

Note) Adjust the auto switch after confirming the operating condition in the actual setting.

Standard Type/Spring Extend Type (T)

Non-rotating Rod Type/Spring Extend Type (T)

(mm)

Auto switch model	Bore size	A	B dimensions				
			Up to 50 st	51 to 100 st	101 to 150 st	151 to 200 st	201 to 250 st
D-M9□(V) D-M9□W(V) D-M9□A(V)	20	11	34.5	59.5	84.5	—	—
	25	10	35	60	85	—	—
	32	11.5	35.5	60.5	85.5	110.5	—
	40	17.5	40.5	65.5	90.5	115.5	140.5
D-A9□(V)	20	7	30.5	55.5	80.5	—	—
	25	6	31	56	81	—	—
	32	7.5	31.5	56.5	81.5	106.5	—
	40	13.5	36.5	61.5	86.5	111.5	136.5
D-H7□ D-H7C D-H7□W D-H7BA D-H7NF	20	6.5	30	55	80	—	—
	25	5.5	30.5	55.5	80.5	—	—
	32	7	31	56	81	106	—
	40	13	36	61	86	111	136
D-G5NT	20	3	26.5	51.5	76.5	—	—
	25	2	27	52	77	—	—
	32	3.5	27.5	52.5	77.5	102.5	—
	40	9.5	32.5	57.5	81.5	107.5	132.5
D-B5□ D-B64	20	1.5	25	50	75	—	—
	25	0.5	25.5	50.5	75.5	—	—
	32	2	26	51	76	101	—
	40	8	31	56	81	106	131
D-C7□ D-C80 D-C73C D-C80C	20	7.5	31	56	81	—	—
	25	6.5	31.5	56.5	81.5	—	—
	32	8	32	57	82	107	—
	40	14	37	62	87	112	137
D-B59W	20	4	28	53	78	—	—
	25	3.5	28.5	53.5	78.5	—	—
	32	5	29	54	79	104	—
	40	11	34	59	84	109	134
D-G39A D-K39A D-A3□A D-A44A	20	1	24.5	49.5	74.5	—	—
	25	0	25	50	75	—	—
	32	1.5	25.5	50.5	75.5	100.5	—
	40	7.5	30.5	55.5	80.5	105.5	130.5

Note) Adjust the auto switch after confirming the operating condition in the actual setting.

Minimum Stroke for Auto Switch Mounting

(Standard type (except single acting type), Non-rotating rod type, Direct mount type,

Direct mount, Non-rotating rod type (except single acting type), Centralized piping type, With end lock)

n: Number of auto switches (mm)

Auto switch model	Number of auto switches				
	With 1 pc.	With 2 pcs.		With n pcs.	
		Different surfaces	Same surface	Different surfaces	Same surface
D-M9□	5	15 <small>Note 1)</small>	40 <small>Note 1)</small>	$20 + 35 \frac{(n-2)}{2}$ (n = 2, 4, 6...) <small>Note 3)</small>	$55 + 35 (n-2)$ (n = 2, 3, 4, 5...)
D-M9□W	10	15 <small>Note 1)</small>	40 <small>Note 1)</small>	$20 + 35 \frac{(n-2)}{2}$ (n = 2, 4, 6...) <small>Note 3)</small>	$55 + 35 (n-2)$ (n = 2, 3, 4, 5...)
D-M9□A	10	15 <small>Note 1)</small>	40 <small>Note 1)</small>	$25 + 35 \frac{(n-2)}{2}$ (n = 2, 4, 6...) <small>Note 3)</small>	$60 + 35 (n-2)$ (n = 2, 3, 4, 5...)
D-A9□	5	15	30 <small>Note 1)</small>	$15 + 35 \frac{(n-2)}{2}$ (n = 2, 4, 6...) <small>Note 3)</small>	$50 + 35 (n-2)$ (n = 2, 3, 4, 5...)
D-M9□V	5	15 <small>Note 1)</small>	35	$20 + 35 \frac{(n-2)}{2}$ (n = 2, 4, 6...) <small>Note 3)</small>	$35 + 35 (n-2)$ (n = 2, 3, 4, 5...)
D-A9□V	5	15	25	$15 + 35 \frac{(n-2)}{2}$ (n = 2, 4, 6...) <small>Note 3)</small>	$25 + 35 (n-2)$ (n = 2, 3, 4, 5...)
D-M9□WV D-M9□AV	10	15 <small>Note 1)</small>	35	$20 + 35 \frac{(n-2)}{2}$ (n = 2, 4, 6...) <small>Note 3)</small>	$35 + 35 (n-2)$ (n = 2, 3, 4, 5...)
D-C7□ D-C80	10	15	50	$15 + 45 \frac{(n-2)}{2}$ (n = 2, 4, 6...) <small>Note 3)</small>	$50 + 45 (n-2)$ (n = 2, 3, 4, 5...)
D-H7□ D-H7□W D-H7BA D-H7NF	10	15	60	$15 + 45 \frac{(n-2)}{2}$ (n = 2, 4, 6...) <small>Note 3)</small>	$60 + 45 (n-2)$ (n = 2, 3, 4, 5...)
D-H7C D-C73C D-C80C	10	15	65	$15 + 50 \frac{(n-2)}{2}$ (n = 2, 4, 6...) <small>Note 3)</small>	$65 + 50 (n-2)$ (n = 2, 3, 4, 5...)
D-G5NT D-B5□/B64	10	15	75	$15 + 50 \frac{(n-2)}{2}$ (n = 2, 4, 6...) <small>Note 3)</small>	$75 + 55 (n-2)$ (n = 2, 3, 4, 5...)
D-B59W	15	20	75	$20 + 50 \frac{(n-2)}{2}$ (n = 2, 4, 6...) <small>Note 3)</small>	$75 + 55 (n-2)$ (n = 2, 3, 4, 5...)
D-G39A <small>Note 4)</small> D-K39A D-A3□A D-A44A	10	35	100	$35 + 30 (n-2)$ (n = 2, 4, 6...)	$100 + 100 (n-2)$ (n = 2, 3, 4, 5...)

Note 3) When "n" is an odd number, an even number that is one larger than this odd number is used for the calculation.

Note 4) The D-A3□A/A44A/G39A/K39A cannot be mounted on the centralized piping type CDM2□P series.

Note 1) Auto switch mounting

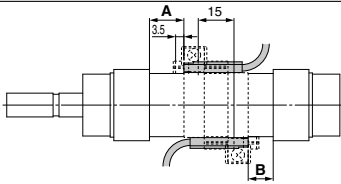
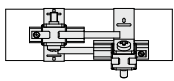
Auto switch model	With 2 auto switches	
	Different surfaces	Same surface
	 <p>The proper auto switch mounting position is 3.5 mm inward from the switch holder edge.</p>	 <p>The auto switch is mounted by slightly displacing it in a direction (cylinder tube circumferential exterior) so that the auto switch and lead wire do not interfere with each other.</p>
D-M9□(V) D-M9□W(V)	15 to 20 stroke <small>Note 2)</small>	40 to 55 stroke <small>Note 2)</small>
D-M9□A(V)	15 to 25 stroke <small>Note 2)</small>	40 to 60 stroke <small>Note 2)</small>
D-A9□(V)	—	30 to 50 stroke <small>Note 2)</small>

Note 2) Minimum stroke for auto switch mounting in types other than those in Note 1.

CJ1

CJP

CJ2

JCM

CM2

CM3

CG1

CG3

JMB

MB

MB1

CA2

CS1

CS2

D-□

-X□

Technical Data

Operating Range

Auto switch model	Bore size (mm)			
	20	25	32	40
D-A9□(V)	6	6	6	6
D-M9□(V) D-M9□W(V) D-M9□A(V)	3	3	4	3.5
D-C7□/C80 D-C73C/C80C	7	8	8	8
D-B5□/B64 D-A3□A/A44A (Note)	8	8	9	9
D-B59W	12	12	13	13
D-H7□/H7□W/H7BA D-G5NT/H7NF	4	4	4.5	5
D-H7C	7	8.5	9	10
D-G39A/K39A (Note)	8	9	9	9

* Values which include hysteresis are for guideline purposes only, they are not a guarantee (assuming approximately ±30% dispersion) and may change substantially depending on the ambient environment.

Note) The D-A3□A/A44A/G39A/K39A cannot be mounted on the centralized piping type CDM2□P series.

Auto Switch Mounting Brackets/Part No.

Auto switch model	Bore size (mm)			
	ø20	ø25	ø32	ø40
D-M9□(V) D-M9□W(V) D-A9□(V)	BM5-020 (A set of a, b, c, d)	BM5-025 (A set of a, b, c, d)	BM5-032 (A set of a, b, c, d)	BM5-040 (A set of a, b, c, d)
D-M9□A(V) (Note 2)	BM5-020S (A set of b, c, d, e)	BM5-025S (A set of b, c, d, e)	BM5-032S (A set of b, c, d, e)	BM5-040S (A set of b, c, d, e)

D-H7□ D-H7□W D-H7NF D-C7□/C80 D-C73C/C80C	BM2-020A (A set of band and screw)	BM2-025A (A set of band and screw)	BM2-032A (A set of band and screw)	BM2-040A (A set of band and screw)
D-H7BA	BM2-020AS (A set of band and screw)	BM2-025AS (A set of band and screw)	BM2-032AS (A set of band and screw)	BM2-040AS (A set of band and screw)
D-B5□/B64 D-B59W D-G5NT	BA2-020 (A set of band and screw)	BA2-025 (A set of band and screw)	BA2-032 (A set of band and screw)	BA2-040 (A set of band and screw)
D-A3□A/A44A (Note 3) D-G39A/K39A	BM3-020 (A set of band and screw)	BM3-025 (A set of band and screw)	BM3-032 (A set of band and screw)	BM3-040 (A set of band and screw)

Note 1) Since the switch bracket (made from nylon) are affected in an environment where alcohol, chloroform, methylamines, hydrochloric acid or sulfuric acid is splashed over, so it cannot be used. Please contact SMC regarding other chemicals.

Note 2) As the indicator LED is projected from the switch unit, indicator LED may be damaged if the switch bracket is fixed on the indicator LED.

Note 3) The D-A3□A/A44A/G39A/K39A cannot be mounted on the centralized piping type CDM2□P series.

Band Mounting Brackets Set Part No.

Set part no.	Contents
BM2-□□□A(S) * S: Stainless steel screw	<ul style="list-style-type: none"> Auto switch mounting band (c) Auto switch mounting screw (d)
BJ4-1	<ul style="list-style-type: none"> Switch bracket (White/PBT) (e) Switch holder (b)
BJ5-1	<ul style="list-style-type: none"> Switch bracket (Transparent/Nylon) (a) Switch holder (b)

Other than the applicable auto switches listed in "How to Order", the following auto switches are mountable.

Refer to pages 1575 to 1701 for the detailed specifications.

Type	Model	Electrical entry	Features
Solid state	D-H7A1, H7A2, H7B	Grommet (In-line)	—
	D-H7NW, H7PW, H7BW		Diagnostic indication (2-color indicator)
	D-H7BA		Water resistant (2-color indicator)
	D-G5NT		With timer
Reed	D-B53, C73, C76	Grommet (In-line)	—
	D-C80		Without indicator light

* With pre-wired connector is also available for solid state auto switches. For details, refer to pages 1648 and 1649.

* Normally closed (NC = b contact) solid state auto switches (D-M9□E(V)) are also available. For details, refer to page 1592-1.



1 PTFE Grease

Symbol
-X446

Applicable Series

Description	Model	Action	Note
Standard type	CM2	Double acting, Single rod	
	CM2W	Double acting, Double rod	
Non-rotating rod type	CM2K	Double acting, Single rod	
	CM2KW	Double acting, Double rod	
Direct mount type	CM2R	Double acting, Single rod	
Direct mount, Non-rotating rod type	CM2RK	Double acting, Single rod	

How to Order

Standard model no. - X446
↓
 PTFE grease

Specifications: Same as standard type

Dimensions: Same as standard type

* When grease is necessary for maintenance, grease pack is available, please order it separately.
GR-F-005 (Grease: 5 g)

Warning Precautions

Be aware that smoking cigarettes etc after your hands have come into contact with the grease used in this cylinder can create a gas that is hazardous to humans.

- CJ1**
- CJP**
- CJ2**
- JCM**
- CM2**
- CM3**
- CG1**
- CG3**
- JMB**
- MB**
- MB1**
- CA2**
- CS1**
- CS2**

- D-□**
- X□**
- Technical Data