

Compact Cylinder: Standard Type Double Acting, Single Rod

Series CQ2

ø12, ø16, ø20, ø25, ø32, ø40, ø50, ø63, ø80, ø100

How to Order

CQ2 **B** **20** **-30** **D** **-** **-**

With auto switch **CDQ2** **B** **20** **-30** **D** **-** **M9BW** **-** **-**

With auto switch (Built-in magnet) **Mounting style**

B	Through-hole (Standard)	F	Rod side flange style
A	Both ends tapped style	G	Head side flange style
L	Foot style	D	Double clevis style

* Mounting brackets are shipped together, (but not assembled).
* Cylinder mounting bolts are not included. Order them separately referring to "Mounting Bolt for CQ2" on pages 606 and 611.

Type

Nil	Pneumatic
H	Air-hydro ⁽¹⁾

Note 1) Bore sizes available for air-hydro type are ø20 to ø100.

Bore size

12	12 mm	40	40 mm
16	16 mm	50	50 mm
20	20 mm	63	63 mm
25	25 mm	80	80 mm
32	32 mm	100	100 mm

Port thread type

Nil	M thread	ø12 to ø25
	Rc	
TN	NPT	ø32 to ø100
TF	G	
F	Built-in One-touch fittings ⁽²⁾	

Note 2) Bore sizes available w/ one-touch fittings are ø32 to ø63. Besides, it is not possible to use for air-hydro type.
Note 3) TF is not available for the air-hydro type.
* For the cylinders without an auto switch, M threads are compatible only for ø32 with 5 strokes.

Number of auto switches

Nil	2 pcs.
S	1 pc.
n	"n" pcs.

Made to Order (Refer to page 603 for details.)

Auto switch

Nil	Without auto switch
------------	---------------------

* Refer to the table below for the applicable auto switch model.

Body option

Nil	Standard (Rod end female thread)
F	With boss in head side
C	With rubber bumper ⁽⁴⁾
M	Rod end male thread

* Combination of body options ("CM", "FC", "FM", "FCM") is available.
Note 4) Air-hydro type with rubber bumper is not available.

Action

D	Double acting
----------	---------------

Cylinder stroke (mm)
For "Standard Stroke" and "Manufacture of intermediate of Stroke", refer to page 603.

Built-in Magnet Cylinder Model

If a built-in magnet cylinder without an auto switch is required, there is no need to enter the symbol for the auto switch.
(Example) CDQ2L32-25D

Applicable Auto Switch/Refer to pages 1263 to 1371 for further information on auto switches.

Type	Special function	Electrical entry	Indicator light	Wiring (Output)	Load voltage		Auto switch model		Lead wire length (m)					Pre-wired connector	Applicable load							
					DC	AC	Perpendicular	In-line	0.5 (Nil)	1 (M)	3 (L)	5 (Z)	None (N)									
Solid state switch		Grommet	Yes	3-wire (NPN)	24V	—		M9NV	M9N	●	●	●	○	—	○	IC circuit						
				3-wire (PNP)				M9PV	M9P	●	●	●	○	—	○							
		2-wire		M9BV				M9B	●	●	●	○	—	○	—							
				J79C				—	●	—	●	●	●	—			—					
	Diagnostic indication (2-color indication)	Grommet	Yes	3-wire (NPN)	24V	—			M9NWW	M9NW	●	●	●	○	—	○	IC circuit					
				3-wire (PNP)					M9PWW	M9PW	●	●	●	○	—	○						
				2-wire					M9BWW	M9BW	●	●	●	○	—	○		—				
				3-wire (NPN)					M9NAV	M9NA	○	○	●	○	—	○						
				3-wire (PNP)					M9PAV	M9PA	○	○	●	○	—	○		IC circuit				
				2-wire					M9BAV	M9BA	○	○	●	○	—	○						
4-wire	—	F79F	●	—	●	○	—	○	○	IC circuit												
Reed switch		Grommet	Yes/No	3-wire (NPN equivalent)	24V	—		A96V	A96	●	—	●	—	—	—	IC circuit	Relay, PLC					
				A72				A72H	●	—	●	—	—	—	—							
				A93V				A93	●	—	●	—	—	—	—			—				
				5V,12V				100V or less	A90V	A90	●	—	●	—	—				—	IC circuit		
		Connector		Yes/No				2-wire	12V	—	A73C	—	●	—	●	●		●	—	—	—	—
									12V	—	A80C	—	●	—	●	●		●	—	—	—	IC circuit
									5V,12V	24V or less	A79W	—	●	—	●	—		—	—	—	—	—
									—	—	A79W	—	●	—	●	—		—	—	—	—	—

* Lead wire length symbols: 0.5 m Nil (Example) M9NW
1 m M (Example) M9NWM
3 m L (Example) M9NL
5 m Z (Example) M9NWZ
None N (Example) J79CN

* Solid state auto switches marked with "○" are produced upon receipt of order.
* D-P4DWL type is available from ø40 up to ø100 only.
* Only for D-P4DWL type, an auto switch is assembled and shipped with the cylinder.

* There are other applicable auto switches other than the listed above. For details, refer to page 769.

* For details about auto switches with pre-wired connector, refer to pages 1328 and 1329.

* When D-A9□(V)/M9□(V)/M9□W(V)/M9□A(V)L types with ø32 to ø50 are mounted on a side other than the port side, order auto switch mounting brackets separately. Refer to page 768 for details.

Compact Cylinder: Standard Type Double Acting, Single Rod **Series CQ2**



JIS Symbol

Double acting,
Single rod

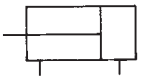

JIS Symbol

With boss in
head side

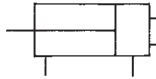

Made to Order Specifications
(For details, refer to pages 1373 to 1565.)

Symbol	Specifications
—XA□	Change of rod end shape
—XB6	Heat resistant cylinder (–10 to 150°C) w/o auto switch only
—XB7	Cold resistant cylinder (–40 to 70°C) w/o auto switch only
—XB9	Low speed cylinder (10 to 50 mm/s)
—XB10	Intermediate stroke (Using exclusive body)
—XB11	Long stroke type, Air-hydro type only
—XB13	Low speed cylinder (5 to 50 mm/s)
—XB14	Cylinder with heat resistant auto switch ø16 to 63 only
—XC4	With heavy duty scraper, ø20 to 100 only
—XC6	Retaining ring, piston rod, rod end nut made of stainless steel
—XC8	Adjustable stroke cylinder/Adjustable extension type
—XC9	Adjustable stroke cylinder/Adjustable retraction type
—XC10	Dual stroke cylinder/Double rod type
—XC11	Dual stroke cylinder/Single rod type
—XC26	Double clevis pins include copper pins and a flat washer.
—XC27	Double clevis pins and Double knuckle pins made of stainless steel (Stainless steel 304)
—XC35	With coil scraper, ø32 to 100 only
—XC36	With boss in rod side
—XC59	Fluoro rubber for seal/Built-in hard plastic magnet, ø20 to 100 only
—X202	Same overall length dimension as Series CQ1, Except ø16, 25
—X203	Same L dimension from rod cover as Series CQ1, ø20, 32 only
—X144	Change of port location, with auto switch ø12 to 25 only
—X271	Fluororubber seals
—X525	Long stroke of adjustable extension stroke cylinder (-XC8)
—X526	Long stroke of adjustable retraction stroke cylinder (XC9)
—X636	Long stroke of dual stroke single rod
—X1876	With concave shape end boss on the cylinder tube head side

Refer to pages 760 to 769 for the specifications of cylinders with auto switches.

- Minimum auto switch mounting stroke
- Proper auto switch mounting position (detection at stroke end) and height
- Operating range
- Switch mounting bracket: Part no.

Specifications(Pneumatic)

Bore size		12	16	20	25	32	40	50	63	80	100
Action	Double acting, Single rod										
Fluid	Air										
Proof pressure	1.5 MPa										
Maximum operating pressure	1.0 MPa										
Minimum operating pressure	0.07 MPa	0.05 MPa									
Ambient and fluid temperature	Without auto switch: –10 to 70°C (No freezing) With auto switch: –10 to 60°C (No freezing)										
Lubrication	Not required (Non-lube)										
Piston speed	50 to 500 mm/s										
Allowable kinetic energy J	Standard	0.022	0.038	0.055	0.09	0.15	0.26	0.46	0.77	1.36	2.27
	With rubber bumper	0.043	0.075	0.110	0.18	0.29	0.52	0.91	1.54	2.71	4.54
Stroke length tolerance	+1.0mm (Note) 0										

Note) Stroke length tolerance dose not include the amount of bumper change.

Specifications(Air-hydro)

Bore size		20	25	32	40	50	63	80	100	
Action	Double acting, Single rod									
Fluid	Turbine oil (Note)									
Proof pressure	1.5 MPa									
Maximum operating pressure	1.0 MPa									
Minimum operating pressure	0.18 MPa	0.1 MPa								
Ambient and fluid temperature	5 to 60°C									
Piston speed	5 to 50 mm/s									
Cushion	None									
Stroke length tolerance	+1.0mm 0									

Note) Refer to Actuator/Common Precautions (5) on page 7.

Manufacture of Intermediate Stroke

Description	Spacer is installed in the standard stroke body.	Exclusive body (-XB10)		
Part no.	Refer to "How to Order" for the standard model no. on page 602.	Suffix "-XB10" to the end of standard model no. on page 602.		
Description	Dealing with intermediate stroke by the 1 mm interval is available by using spacer with standard stroke.	Dealing with the stroke by the 1 mm interval by using an exclusive body with the stroke.		
Stroke range	Bore size	Stroke range	Bore size	Stroke range
	12, 16	1 to 29	12, 16	6 to 29
	20, 25	1 to 49	20, 25	6 to 49
Example	32 to 100	1 to 99	32, 40	6 to 99
			50 to 100	11 to 99
Example	Part No.: CQ2B50-57D 18 mm width spacer is installed in the standard CQ2B50-75D. B dimension is 115.5 mm.	Part no. CQ2B50-57D-XB10 Makes 57 stroke tube. B dimension is 97.5 mm.		



- Air-hydro type is excluded.
- In the case of spacer type, intermediate stroke with bumper for ø40 to ø100, it can be manufactured by 5 mm intervals in 5 mm and 55 to 95 mm.
- In the case of an exclusive body with ø32 to ø100 (-XB10) with the stroke length exceeding 50 mm, the reference values of the longitudinal dimension will be changed. Calculate length dimensions by deducting from those of 75 or 100 mm stroke models.
- Regarding the long stroke which exceeds the stroke range, refer to page 671 for the long stroke type of either CQS or CQ2.

Standard Stroke

Pneumatic

Bore size (mm)	Standard stroke (mm)
12, 16	5, 10, 15, 20, 25, 30
20, 25	5, 10, 15, 20, 25, 30, 35, 40, 45, 50
32, 40	5, 10, 15, 20, 25, 30, 35, 40, 45, 50, 75, 100
50 to 100	10, 15, 20, 25, 30, 35, 40, 45, 50, 75, 100

- When stroke exceeds the standard range, refer to page 670.

Air-hydro

Bore size (mm)	Standard stroke (mm)
20, 25	5, 10, 15, 20, 25, 30, 35, 40, 45, 50
32, 40	5, 10, 15, 20, 25, 30, 35, 40, 45, 50, 75, 100
50, 63, 80, 100	10, 15, 20, 25, 30, 35, 40, 45, 50, 75, 100

CUJ

CU

CQS

CQ2

RQ

CQM

MU

D-□

-X□

Individual

-X□

Technical data

Type

Bore size (mm)		12	16	20	25	32	40	50	63	80	100		
Pneumatic	Mounting	Through-hole (Standard)	●	●	●	●	●	●	●	●	●		
		Both ends tapped style	●	●	●	●	●	●	●	●	●		
	Built-in magnet		●	●	●	●	●	●	●	●	●		
	Piping	Screw-in type	—	M5 x 0.8	M5 x 0.8	M5 x 0.8	M5 x 0.8	M5 x 0.8 Rc1/8 ⁽¹⁾	Rc 1/8	Rc 1/4	Rc 1/4	Rc 3/8	Rc 3/8
			TN	—	—	—	—	NPT1/8	NPT1/8	NPT1/4	NPT1/4	NPT3/8	NPT3/8
			TF	—	—	—	—	G1/8	G1/8	G1/4	G1/4	G3/8	G3/8
		Built-in One-touch fittings	—	—	—	—	—	—	—	—	—	—	
	Rod end male thread		●	●	●	●	●	●	●	●	●	●	
	With rubber bumper		●	●	●	●	●	●	●	●	●	●	
	With boss in head side		●	●	●	●	●	●	●	●	●	●	
Air-hydro	Mounting	Through-hole (Standard)	—	—	●	●	●	●	●	●	●		
		Both ends tapped style	—	—	●	●	●	●	●	●	●		
	Built-in magnet		—	—	●	●	●	●	●	●	●		
	Piping	Screw-in type	—	—	M5 x 0.8	M5 x 0.8	M5 x 0.8 Rc1/8 ⁽¹⁾	Rc 1/8	Rc 1/4	Rc 1/4	Rc 3/8	Rc 3/8	
			TN	—	—	—	—	NPT1/8	NPT1/8	NPT1/4	NPT1/4	NPT3/8	NPT3/8
	Rod end male thread		—	—	●	●	●	●	●	●	●	●	
	With boss in head side		—	—	●	●	●	●	●	●	●	●	

Note 1) For a $\phi 32$ cylinder without an auto switch, M5 x 0.8 is used for 5-stroke piping dimension. Thus, do not enter a symbol for the port tread type.

Note 2) In the case of built-in fitting, the 5 mm stroke with $\phi 32$ bore is the same external dimensions as 10 mm stroke.

Note 3) One-touch fittings cannot be replaced.

Mounting Bracket Part No.

Bore size (mm)	Foot ⁽⁴⁾	Flange	Double clevis
12	CQ-L012	CQ-F012	CQ-D012
16	CQ-L016	CQ-F016	CQ-D016
20	CQ-L020	CQ-F020	CQ-D020
25	CQ-L025	CQ-F025	CQ-D025
32	CQ-L032	CQ-F032	CQ-D032
40	CQ-L040	CQ-F040	CQ-D040
50	CQ-L050	CQ-F050	CQ-D050
63	CQ-L063	CQ-F063	CQ-D063
80	CQ-L080	CQ-F080	CQ-D080
100	CQ-L100	CQ-F100	CQ-D100

Note 4) When ordering foot bracket, order 2 pieces per cylinder.

Note 5) Parts belonging to each bracket are as follows. Foot, Flange: Body mounting bolt/Double clevis: Clevis pin, Type C retaining ring for axis, body mounting bolt

⚠ Precautions

Be sure to read before handling.

Refer to front matters 54 and 55 for Safety Instructions and pages 3 to 11 for Actuator and Auto Switch Precautions.

Retaining Ring Installation/Removal

⚠ Caution

- For installation and removal, use an appropriate pair of pliers (tool for installing a type C retaining ring).
- Even if a proper plier (tool for installing type C retaining ring) is used, it is likely to inflict damage to a human body or peripheral equipment, as a retaining ring may be flown out of the tip of a plier (tool for installing a type C retaining ring). Be much careful with the popping of a retaining ring. Besides, be certain that a retaining ring is placed firmly into the groove of rod cover before supplying air at the time of installment.

Mounting

⚠ Caution

Series CQ2 compact cylinders are designed to create compact mechanical equipment and promote space saving. Thus, if it is used in the same manner as conventional cylinders such as tie-rod cylinders, it may degrade the performance.

Pay sufficient attention to the operating conditions when using.

(1) Allowable lateral load

Lateral load that can apply to the piston rod end is limited. If a cylinder is used with a lateral load over the limit, it may cause air leakage due to abnormal friction of seals, galling of cylinder tubes and pistons, or abnormal friction of the bearing part.

The lateral load applied to the piston must be within the allowable range indicated in this catalog. When the load exceeds the limit, use a double rod cylinder, install a guide, or change the bore size to suit the load in order to make the load within the allowable range. As a standard product, a lateral load resistant type that is resistant to approx. 2 times more than the conventional compact CQ2 series is also available (pages 723 to 733).

Mounting

⚠ Caution

(2) Connection with workpiece

When a workpiece is mounted on the piston rod end, connect them aligning the center of piston rod and workpiece. If they are off-center, lateral load is generated and phenomena mentioned in (1) may occur. In order not to apply the off-center load, use of a floating joint or simple joint is recommended.

(3) Simultaneous use of multiple cylinders

It is difficult to control the speed of pneumatic cylinders. The following conditions cause speed change: change in supply pressure, load, temperature and lubrication, performance difference of each cylinder, deterioration of each part over time, etc. A speed controller can be used to control the speed of multiple cylinders simultaneously for a short period of time, but depending on conditions, it may not work as desired. If multiple cylinders cannot operate simultaneously, unreasonable force is applied to the piston rod because cylinder positions may not be the same.

This may cause abnormal friction of seals and bearings, and galling of cylinder tubes and pistons. Do not use an application to operate several cylinders simultaneously by adjusting cylinder speed. If this is inevitable, use a high rigid guide against load, so that the cylinder is not damaged even when the each cylinder output is slightly different.

Allowable Kinetic Energy

Table (1) Load Mass and Piston Speed. [J]

Bore size (mm)	12	16	20	25	32	40	50	63	80	100
Standard Allowable kinetic energy: Ea	0.022	0.038	0.055	0.09	0.15	0.26	0.46	0.77	1.36	2.27
With rubber bumper Allowable kinetic energy: Eb	0.043	0.075	0.110	0.18	0.29	0.52	0.91	1.54	2.71	4.54

$$\text{Kinetic energy } E \text{ (J)} = \frac{(m_1+m_2)V^2}{2}$$

m1: Weight of cylinder operating part kg
m2: Load mass kg
V : Piston speed m/s

Table (2) Mass of Cylinder Movable Parts/Without Built-in Magnet (g)

Bore size (mm)	Cylinder stroke (mm)											
	5	10	15	20	25	30	35	40	45	50	75	100
12	5	6	7	8	10	11	—	—	—	—	—	—
16	9	11	13	15	17	19	—	—	—	—	—	—
20	15	18	21	24	27	31	34	37	40	44	—	—
25	24	28	33	37	42	46	51	55	60	64	—	—
32	45	52	60	68	76	84	92	100	107	115	170	209
40	64	72	80	88	96	104	112	119	127	135	190	229
50	—	117	129	141	153	166	178	190	202	214	300	361
63	—	153	165	177	190	202	214	226	239	251	337	398
80	—	270	289	308	327	347	366	385	404	423	557	653
100	—	487	515	543	570	598	625	653	681	708	901	1038

Table (3) Mass of Cylinder Movable Parts/With Built-in Magnet (g)

Bore size (mm)	Cylinder stroke (mm)											
	5	10	15	20	25	30	35	40	45	50	75	100
12	8	9	10	11	12	13	—	—	—	—	—	—
16	16	18	20	22	24	26	—	—	—	—	—	—
20	28	31	34	37	40	44	47	50	53	56	—	—
25	44	48	53	57	62	66	71	75	80	84	—	—
32	78	86	93	101	109	117	125	133	140	148	187	227
40	109	117	125	133	140	148	156	164	172	180	219	258
50	—	187	199	211	223	236	248	260	272	285	346	407
63	—	254	266	278	290	303	315	327	339	352	413	474
80	—	433	453	472	491	510	530	549	568	587	683	778
100	—	741	768	796	823	851	879	906	934	962	1099	1236

Table (4) (g)

Bore size (mm)		12	16	20	25	32	40	50	63	80	100
Rod end male thread	Thread	1.5	3	6	12	26	27	53	53	120	175
	Nut	1	2	4	8	17	17	32	32	49	116
With rubber bumper		0	0	-2	-3	-3	-7	-9	-18	-31	-56

Calculation: (Example) **CDQ2B32-20DCM**

- Cylinder mass: CDQ2B32-20D101 g
- Option mass: Rod end male thread 43 g
- With rubber bumper -3 g
- 141 g

Allowable Lateral Load at Rod End

Without Auto Switch

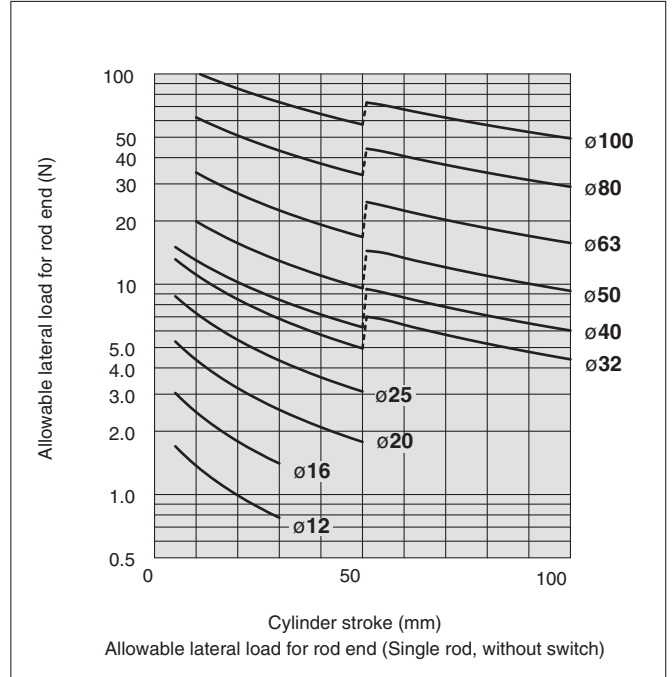

With Auto Switch

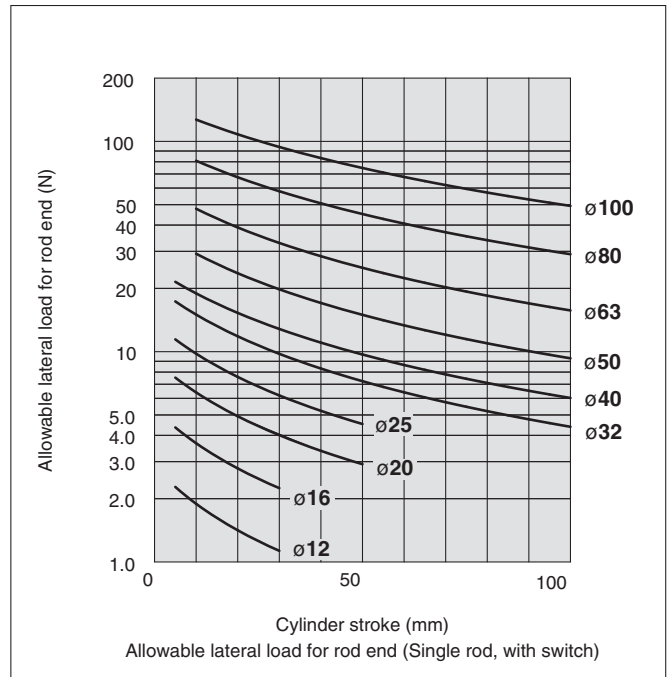

If an allowable lateral load at rod end is exceeding the value in the graph, we recommend anti-lateral load type cylinder be used.

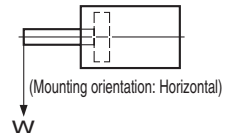

- CUJ
- CU
- CQS
- CQ2**
- RQ
- CQM
- MU

- D-□
- X□
- Individual -X□
- Technical data

Construction

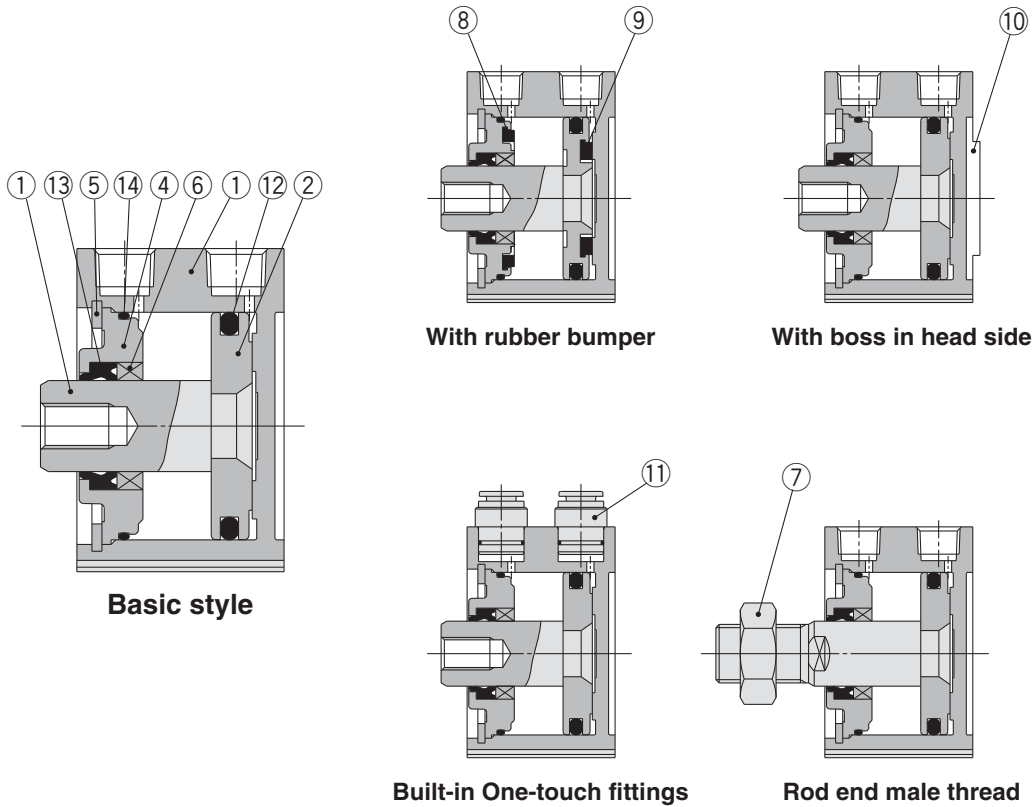

Component Parts

No.	Description	Material	Note
1	Cylinder tube	Aluminum alloy	Hard anodized
2	Piston	Aluminum alloy	Chromated
3	Piston rod	Stainless steel	ø12 to ø25
		Carbon steel	ø32 to ø100, Hard chrome plated
4	Collar	Aluminum alloy	ø12 to ø40, Anodized
		Aluminum alloy casted	ø50 to ø100, Chromated, painted
5	Retaining ring	Carbon tool steel	Phosphate coated
6	Bushing	Bearing alloy	For ø50 or larger only
7	Rod end nut	Carbon steel	Nickel plated
8	Bumper A	Urethane	

No.	Description	Material	Note
9	Bumper B	Urethane	
10	Centering location ring	Aluminum alloy	Hard anodized ø20 to ø100
11	One-touch fitting	—	ø32 to ø63
12	Piston seal	NBR	
13	Rod seal	NBR	
14	Gasket	NBR	

Replacement Parts/ Seal Kit (Pneumatic)

Bore size (mm)	Kit no.	Contents
12	CQ2B12-PS	Set of nos. above ⑫, ⑬, ⑭.
16	CQ2B16-PS	
20	CQ2B20-PS	
25	CQ2B25-PS	
32	CQ2B32-PS	
40	CQ2B40-PS	
50	CQ2B50-PS	
63	CQ2B63-PS	
80	CQ2B80-PS	
100	CQ2B100-PS	

* Seal kit includes ⑫ ⑬ ⑭. Order the seal kit, based on each bore size.
* Since the grease kit does not include a grease pack, order it separately.
Grease pack part no.: GR-S-010 (10 g)

Replacement Parts/ Seal Kit (Air-hydro)

Bore size (mm)	Kit no.	Contents
20	CQ2BH20-PS	Set of nos. above ⑫, ⑬, ⑭.
25	CQ2BH25-PS	
32	CQ2BH32-PS	
40	CQ2BH40-PS	
50	CQ2BH50-PS	
63	CQ2BH63-PS	
80	CQ2BH80-PS	
100	CQ2BH100-PS	

* Seal kit includes ⑫ ⑬ ⑭. Order the seal kit, based on each bore size.
* Since the grease kit does not include a grease pack, order it separately.
Grease pack part no.: GR-S-010 (10 g)

CUJ

CU

CQS

CQ2

RQ

CQM

MU

D-□

-X□

Individual
-X□

Technical
data

Series CQ2

Clean Series

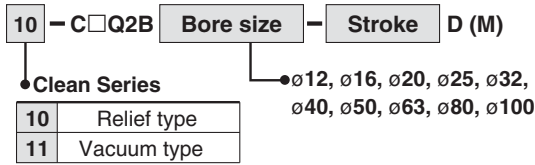

The type which is applicable for using inside the clean room graded Class 100 by making an actuator's rod section a double seal construction and discharging by relief port directly to the outside of clean room.



Specifications

Action	Double acting, Single rod	
Bore size (mm)	$\phi 12, \phi 16, \phi 20, \phi 25, \phi 32, \phi 40, \phi 50, \phi 63$	$\phi 80, \phi 100$
Proof pressure	1.5 MPa	
Maximum operating pressure	1.0 MPa	
Cushion	None ^(Note)	
Piston speed	30 to 400 mm/s	30 to 300 mm/s
Mounting	Through-hole	

Note) $\phi 12$ with switch: With rubber bumper (Standard)

For details, refer to the separate catalog, "Pneumatic Clean Series".

Construction

Series 10-CQ2 (Double seal type)

Series 11-CQ2 (Single seal, Vacuum suction)

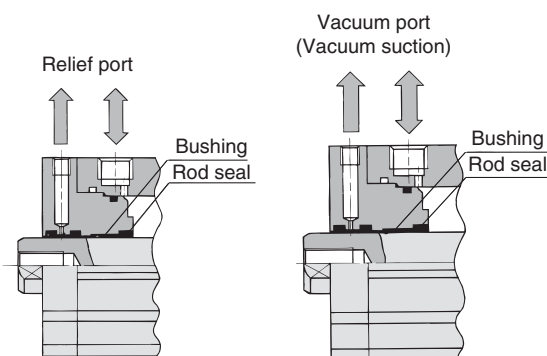

A relief port is provided in the area between the double rod seals to discharge the exhaust air outside of the clean room. Thus, the amount of dust generated has been reduced to 1/20 of that of an ordinary cylinder.

Structurally identical to the "10-" series, the outer rod seal has been removed to evacuate through the vacuum port. This draws out any external air from the clearance between the rod and the cover to practically eliminate the generation of external dust. This should be used in an application that requires an even higher level of cleanliness than the 10- series.

Copper and Fluorine-free Series (For CRT manufacturing process)



To prevent the influence of copper ions or halogen ions during CRT manufacturing processes, copper and fluorine materials are not used in the component parts.



Specifications

Action	Double acting, Single rod	
Bore size (mm)	$\phi 12, \phi 16, \phi 20, \phi 25, \phi 32, \phi 40, \phi 50, \phi 63, \phi 80, \phi 100$	
Proof pressure	1.5 MPa	
Maximum operating pressure	1.0 MPa	
Cushion	None, Rubber bumper	
Piston speed	50 to 500 mm/s	
Mounting	Through-hole, Both ends tapped style	

Water Resistant

Refer to pages 747 to 759 for details.

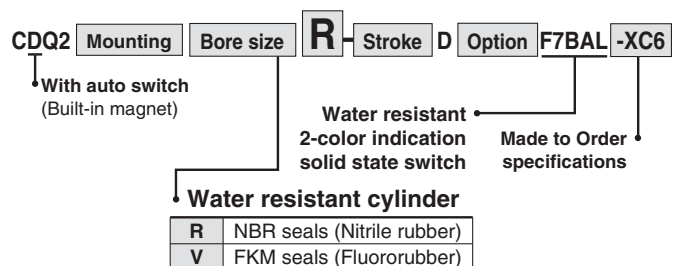

Ideal for use under the atmosphere having coolant for machine tools, etc. Compatible for the environment, where waterdrops are splashed around the food processing machinery and the car washers, etc.



Specifications

Action	Double acting, Single rod	
Bore size (mm)	$\phi 20, \phi 25, \phi 32, \phi 40, \phi 50, \phi 63, \phi 80, \phi 100$	
Cushion	None	
Made to order	Snap ring/Piston rod/Rod end nut material: Stainless steel (-XC6)	

* Specifications other than above are the same as standard, basic style.

Smooth cylinder

CQ2 Y Mounting bracket Bore size – Stroke D(C)(M)
 ↓
 • Smooth cylinder

Smooth operation with minimal sticking and slipping at low speeds.
 Dual-side low friction operation is possible.



Specifications

Bore size (mm)	32	40	50	63	80	100
Model	Pneumatic (Non-lube) type					
Fluid	Air					
Proof pressure	1.05 MPa					
Maximum operating pressure	0.7 MPa					
Ambient and fluid temperature	Without auto switch: -10 to 70°C (No freezing) With auto switch: -10 to 60°C (No freezing)					
Cushion	Rubber bumper (Standard)					
Rod end thread	Female thread					
Stroke length tolerance	+1.0 0					
Mounting	Through-hole					
Piston speed	5 to 500 mm/s					
Allowable leakage	0.5ℓ/min (ANR) or less					

Minimum Operating Pressure

Bore size (mm)	32	40	50	63	80	100
Minimum operating pressure (MPa)	0.02				0.01	

Refer to Best Pneumatics No. 3 for details.

Low-speed cylinder

CQ2 X Mounting bracket Bore size – Stroke D(C)(M)
 ↓
 • Low-speed cylinder

Smooth operation with minimal sticking and slipping at low speeds.
 Starts smoothly with minimal ejection even after being rendered for hours.



Specifications

Bore size (mm)	32	40	50	63	80	100
Model	Pneumatic (Non-lube) type					
Fluid	Air					
Proof pressure	1.5 MPa					
Maximum operating pressure	1.0 MPa					
Ambient and fluid temperature	Without auto switch: -10 to 70°C (No freezing) With auto switch: -10 to 60°C (No freezing)					
Rubber bumper	None					
Rod end thread	Female thread					
Stroke length tolerance	+1.0 0					
Mounting	Through-hole					
Piston speed	0.5 to 300 mm/s					

Note 1) In the case of without auto switch, M5 x 0.8 is used for 5 stroke only.

Minimum Operating Pressure

Bore size (mm)	32	40	50	63	80	100
Minimum operating pressure (MPa)	0.025				0.01	

Refer to Best Pneumatics No. 3 for details.

CUJ

CU

CQS

CQ2

RQ

CQM

MU

D-□

-X□

Individual
-X□

Technical
data

Compact Cylinder: Standard Type

Double Acting, Single rod

Series **CDQ2**

With Auto Switch

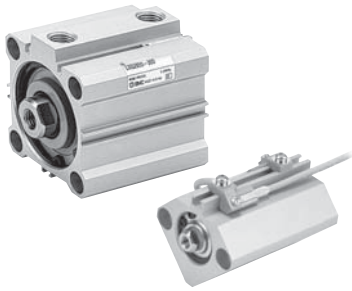

Refer to page below for further information on auto switches.

Auto switch specifications	P. 1263 to 1371
Proper auto switch mounting position and height	P. 760 to 769
Minimum stroke for auto switch mounting	
Operating range	
Switch mounting bracket: Part no.	

Mass

(g)

Bore size (mm)	Cylinder stroke (mm)											
	5	10	15	20	25	30	35	40	45	50	75	100
12	47	54	60	67	74	80	—	—	—	—	—	—
16	73	82	92	101	110	119	—	—	—	—	—	—
20	109	122	136	150	164	178	191	205	219	233	—	—
25	144	161	178	195	211	228	245	262	278	295	—	—
32	190	211	232	252	273	294	315	335	356	377	482	587
40	282	305	328	351	375	398	421	444	467	490	610	730
50	—	487	523	559	595	632	668	704	740	777	965	1153
63	—	696	737	778	819	860	901	941	982	1023	1235	1446
80	—	1258	1325	1393	1461	1529	1597	1665	1732	1800	2135	2469
100	—	2118	2209	2299	2390	2481	2572	2662	2753	2844	3304	3764

Additional Mass

(g)

Bore size (mm)	12	16	20	25	32	40	50	63	80	100	
Both ends tapped style	1	1	3	3	6	6	6	19	45	45	
Rod end male thread	Male thread	1.5	3	6	12	26	27	53	53	120	175
	Nut	1	2	4	8	17	17	32	32	49	116
With boss in head side	0.7	1.3	2	3	5	7	13	25	45	96	
With rubber bumper	0	-1	-2	-3	-3	-7	-9	-18	-31	-56	
Built-in One-touch fittings	—	—	—	—	12	12	21	21	—	—	
Foot style (Including mounting bolt)	49	62	147	169	143	155	243	324	696	1062	
Rod side flange style (Including mounting bolt)	54	67	131	153	180	214	373	559	1056	1365	
Rear flange style (Including mounting bolt)	52	63	124	144	165	198	348	534	1017	1309	
Double clevis style (Including pin, retaining ring, bolt)	29	35	78	114	151	196	393	554	1109	1887	

Calculation: (Example) **CDQ2D32-20DCM**

- Cylinder mass: CDQ2B32-20D 252 g
- Option mass: Both ends tapped style 6 g
- Rod end male thread 43 g
- With rubber bumper -3 g
- Double clevis style 151 g
- 449 g

Add each mass of auto switches and mounting brackets.

Auto Switch Mounting Bracket Mass

Mounting bracket part no.	Applicable bore (mm)	Mass (g)
BQ-1	ø12 to ø25	1.5
BQ-2	ø32 to ø100	1.5
BQ2-012	ø12 to ø25	5

For the auto switch mass, refer to page 1263 to 1371.

Construction

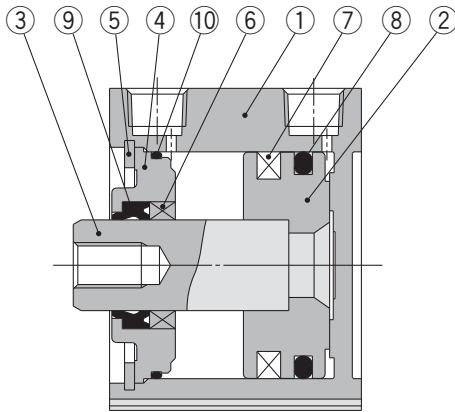

Component Parts

No.	Description	Material	Note
1	Cylinder tube	Aluminum alloy	Hard anodized
2	Piston	Aluminum alloy	Chromated
3	Piston rod	Stainless steel	ø12 to ø25
		Carbon steel	ø32 to ø100, Hard chrome plated
4	Collar	Aluminum alloy	ø12 to ø40, Anodized
		Aluminum alloy casted	ø50 to ø100, Chromated, painted
5	Retaining ring	Carbon tool steel	Phosphate coated
6	Bushing	Bearing alloy	For ø50 or larger only
7	Magnet	—	
8	Piston seal	NBR	
9	Rod seal	NBR	
10	Gasket	NBR	

Replacement Parts/Seal Kit Pneumatic

Bore size(mm)	Kit no.	Contents
12	CQ2B12-PS	Set of nos. above ⑧, ⑨, ⑩.
16	CQ2B16-PS	
20	CQ2B20-PS	
25	CQ2B25-PS	
32	CQ2B32-PS	
40	CQ2B40-PS	
50	CQ2B50-PS	
63	CQ2B63-PS	
80	CQ2B80-PS	
100	CQ2B100-PS	

* Seal kits includes ⑧ ⑨ ⑩. Order the seal kit, based on each bore size.
* Since the grease kit does not include a grease pack, order it separately.
Grease pack part no.: GR-S-010 (10 g)

Replacement Parts/Seal Kit Air-hydro

Bore size(mm)	Kit no.	Contents
20	CQ2BH20-PS	Set of nos. above ⑧, ⑨, ⑩.
25	CQ2BH25-PS	
32	CQ2BH32-PS	
40	CQ2BH40-PS	
50	CQ2BH50-PS	
63	CQ2BH63-PS	
80	CQ2BH80-PS	
100	CQ2BH100-PS	

* Seal kits includes ⑧ ⑨ ⑩. Order the seal kit, based on each bore size.
* Since the grease kit does not include a grease pack, order it separately.
Grease pack part no.: GR-S-010 (10 g)

Mounting Bolt for CDQ2/With Auto Switch

Mounting method: Mounting bolt for through-hole mounting style of CDQ2B is available as an option.

Ordering: Add the word "Bolt" in front of the bolts to be used.

Example) Bolt M3 x 35L 2 pcs.

Material: Chromium molybdenum steel
Surface treatment: Nickel plated

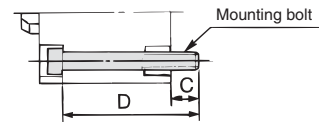

Cylinder model	C	D	Mounting bolt size
CDQ2B12-5D	5.5	35	M3 x 35L
-10D		40	x 40L
-15D		45	x 45L
-20D		50	x 50L
-25D		55	x 55L
-30D		65	x 60L
CDQ2B16-5D	8	40	M3 x 40L
-10D		45	x 45L
-15D		50	x 50L
-20D		55	x 55L
-25D		60	x 60L
-30D		65	x 65L
CDQ2B20-5D	10.5	40	M5 x 40L
-10D		45	x 45L
-15D		50	x 50L
-20D		55	x 55L
-25D		60	x 60L
-30D		65	x 65L
-35D		70	x 70L
-40D		75	x 75L
-45D		80	x 80L
-50D		85	x 85L
CDQ2B25-5D	9.5	40	M5 x 40L
-10D		45	x 45L
-15D		50	x 50L
-20D		55	x 55L
-25D		60	x 60L
-30D		65	x 65L
-35D		70	x 70L
-40D		75	x 75L
-45D		80	x 80L
-50D		85	x 85L

Cylinder model	C	D	Mounting bolt size
CDQ2B32-5D	9	40	M5 x 40L
-10D		45	x 45L
-15D		50	x 50L
-20D		55	x 55L
-25D		60	x 60L
-30D		65	x 65L
-35D		70	x 70L
-40D		75	x 75L
-45D		80	x 80L
-50D		85	x 85L
CDQ2B40-5D	7.5	45	M5 x 45L
-10D		50	x 50L
-15D		55	x 55L
-20D		60	x 60L
-25D		65	x 65L
-30D		70	x 70L
-35D		75	x 75L
-40D		80	x 80L
-45D		85	x 85L
-50D		90	x 90L
CDQ2B50-10D	12.5	55	M6 x 55L
-15D		60	x 60L
-20D		65	x 65L
-25D		70	x 70L
-30D		75	x 75L
-35D		80	x 80L
-40D		85	x 85L
-45D		90	x 90L
-50D		95	x 95L
-75D		120	x 120L
-100D	145	x 145L	

Cylinder model	C	D	Mounting bolt size
CDQ2B63-10D	14.5	60	M8 x 60L
-15D		65	x 65L
-20D		70	x 70L
-25D		75	x 75L
-30D		80	x 80L
-35D		85	x 85L
-40D		90	x 90L
-45D		95	x 95L
-50D		100	x 100L
-75D		125	x 125L
CDQ2B80-10D	15	65	M10 x 65L
-15D		70	x 70L
-20D		75	x 75L
-25D		80	x 80L
-30D		85	x 85L
-35D		90	x 90L
-40D		95	x 95L
-45D		100	x 100L
-50D		105	x 105L
-75D		130	x 130L
CDQ2B100-10D	15.5	75	M10 x 75L
-15D		80	x 80L
-20D		85	x 85L
-25D		90	x 90L
-30D		95	x 95L
-35D		100	x 100L
-40D		105	x 105L
-45D		110	x 110L
-50D		115	x 115L
-75D		140	x 140L
-100D	165	x 165L	

CUJ

CU

CQS

CQ2

RQ

CQM

MU

D-□

-X□

Individual

-X□

Technical data

Series CQ2

Dimensions

Ø12 to Ø25/Without Auto Switch

Basic style (Through-hole): CQ2B

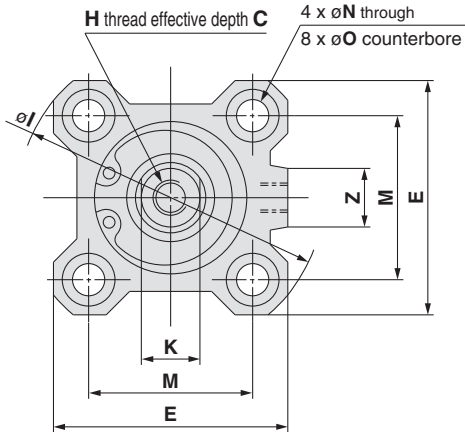

Both ends tapped style: CQ2A

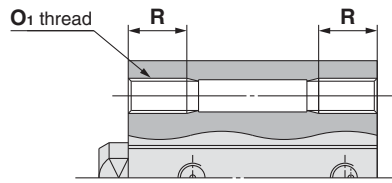

Both Ends Tapped Style (mm)

Bore size (mm)	O ₁	R
12	M4 x 0.7	7
16	M4 x 0.7	7
20	M6 x 1.0	10
25	M6 x 1.0	10

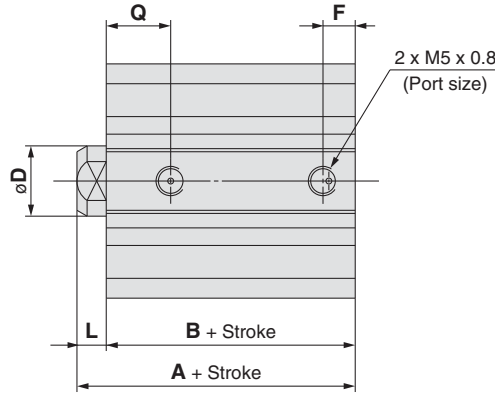

With boss in head side

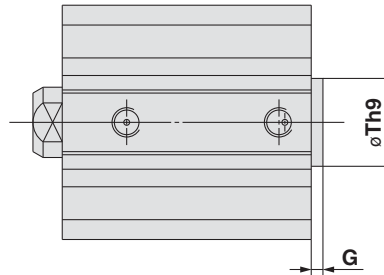

With Boss in Head Side (mm)

Bore size (mm)	G	Th9
12	1.5	15 ⁰ _{-0.043}
16	1.5	20 ⁰ _{-0.052}
20	2	13 ⁰ _{-0.043}
25	2	15 ⁰ _{-0.043}

Note) With boss in rod side : Option
(Suffix "-XC36" to the end of part number.)

Rod end male thread

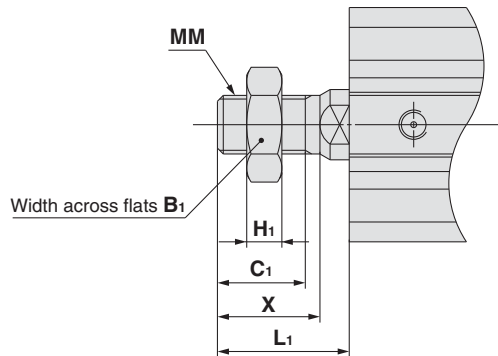

Rod End Male Thread (mm)

Bore size (mm)	B ₁	C ₁	H ₁	L ₁	MM	X
12	8	9	4	14	M5 x 0.8	10.5
16	10	10	5	15.5	M6 x 1.0	12
20	13	12	5	18.5	M8 x 1.25	14
25	17	15	6	22.5	M10 x 1.25	17.5

Basic Style

Bore size (mm)	Stroke range (mm)	A	B	C	D	E	F	H	I	K	L	M	N	O	Q	Z
12	5 to 30	20.5	17	6	6	25	5	M3 x 0.5	32	5	3.5	15.5	3.5	6.5 depth 3.5	7.5	—
16	5 to 30	22	18.5	8	8	29	5.5	M4 x 0.7	38	6	3.5	20	3.5	6.5 depth 3.5	8	10
20	5 to 50	24	19.5	7	10	36	5.5	M5 x 0.8	47	8	4.5	25.5	5.5	9 depth 7	9	10
25	5 to 50	27.5	22.5	12	12	40	5.5	M6 x 1.0	52	10	5	28	5.5	9 depth 7	11	10

Note) External dimensions with rubber bumper are same as standard type as shown above.
* For details about the rod end nut and accessory brackets, refer to page 620.

For calculation on the longitudinal dimension of the intermediate strokes, refer to page 603.

Foot style: CQ2L

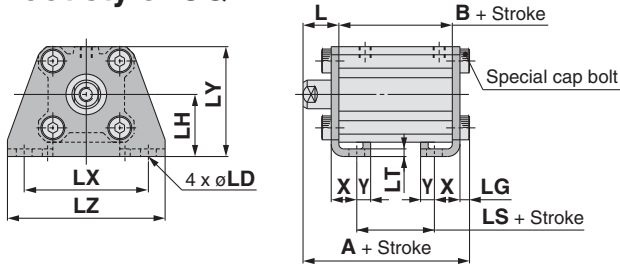

Rod end male thread

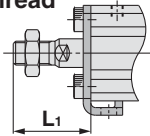

Rod side flange style: CQ2F

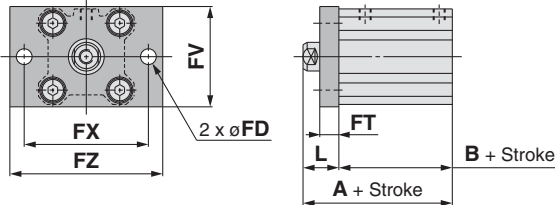

Rod end male thread

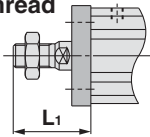

Head side flange style: CQ2G

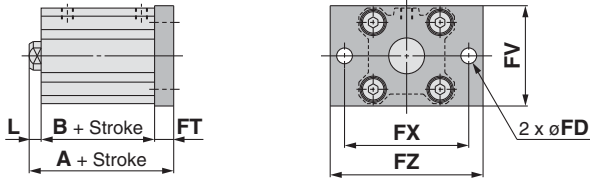

Rod end male thread

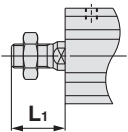

Double clevis style: CQ2D

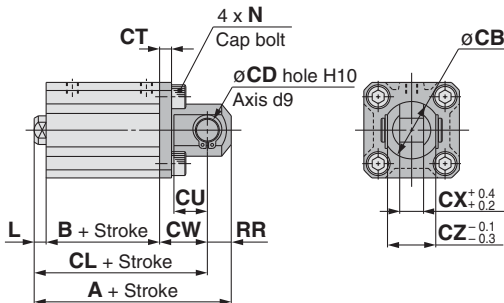

Rod end male thread

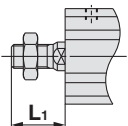

Foot Style

Bore size (mm)	Stroke range (mm)	A	B	L	L ₁	LD	LG	LH	LS	LT	LX	LY	LZ	X	Y
12	5 to 30	35.3	17	13.5	24	4.5	2.8	17	5	2	34	29.5	44	8	4.5
16	5 to 30	36.8	18.5	13.5	25.5	4.5	2.8	19	6.5	2	38	33.5	48	8	5
20	5 to 50	41.2	19.5	14.5	28.5	6.6	4	24	7.5	3.2	48	42	62	9.2	5.8
25	5 to 50	44.7	22.5	15	32.5	6.6	4	26	7.5	3.2	52	46	66	10.7	5.8

Foot bracket material: Carbon steel
Surface treatment: Nickel plated

Rod Side Flange Style

Bore size (mm)	Stroke range (mm)	A	B	FD	FT	FV	FX	FZ	L	L ₁
12	5 to 30	30.5	17	4.5	5.5	25	45	55	13.5	24
16	5 to 30	32	18.5	4.5	5.5	30	45	55	13.5	25.5
20	5 to 50	34	19.5	6.6	8	39	48	60	14.5	28.5
25	5 to 50	37.5	22.5	6.6	8	42	52	64	15	32.5

Flange bracket material: Carbon steel
Surface treatment: Nickel plated

Head Side Flange Style

Bore size (mm)	Stroke range (mm)	A	L	L ₁
12	5 to 30	26	3.5	14
16	5 to 30	27.5	3.5	15.5
20	5 to 50	32	4.5	18.5
25	5 to 50	35.5	5	22.5

(* Dimensions except A, L and L₁ are the same as rod side flange style.)

Flange bracket material: Carbon steel
Surface treatment: Nickel plated

Double Clevis Style

Bore size (mm)	Stroke range (mm)	A	B	CB	CD	CL	CT	CU	CW	CX	CZ	L	L ₁	N	RR
12	5 to 30	40.5	17	12	5	34.5	4	7	14	5	10	3.5	14	M4 x 0.7	6
16	5 to 30	43	18.5	14	5	37	4	10	15	6.5	12	3.5	15.5	M4 x 0.7	6
20	5 to 50	51	19.5	20	8	42	5	12	18	8	16	4.5	18.5	M6 x 1.0	9
25	5 to 50	57.5	22.5	24	10	47.5	5	14	20	10	20	5	22.5	M6 x 1.0	10

Double clevis bracket material: Carbon steel
Surface treatment: Nickel plated

* For details about the rod end nut and accessory brackets, refer to page 620.
** Double clevis pins and retaining rings are included.

CUJ

CU

CQS

CQ2

RQ

CQM

MU

D-□

-X□

Individual
-X□

Technical
data

Series CQ2

Dimensions

Ø12 to Ø25/With Auto Switch

Basic style (Through-hole): CDQ2B

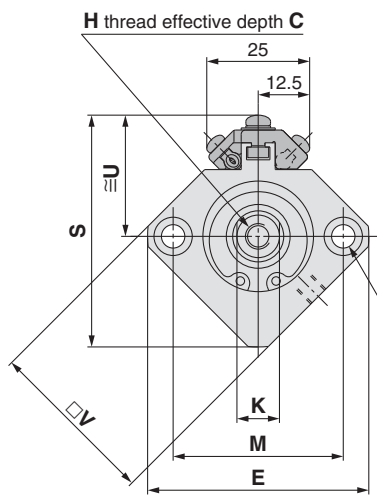

Both ends tapped style: CDQ2A

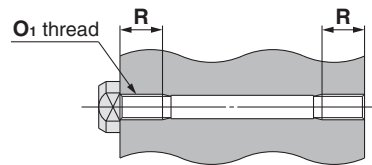

Both Ends Tapped Style (mm)

Bore size (mm)	O ₁	R
12	M4 x 0.7	7
16	M4 x 0.7	7
20	M6 x 1.0	10
25	M6 x 1.0	10

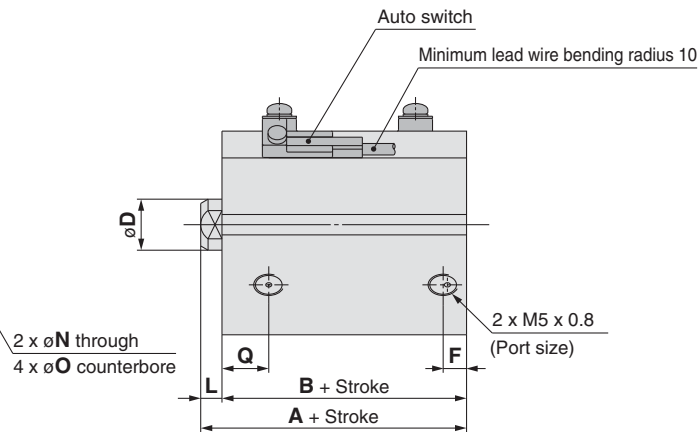

With boss in head side

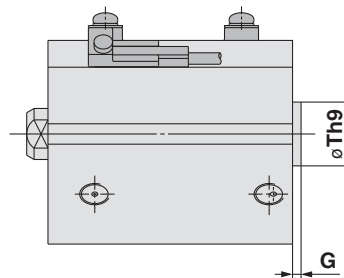

With Boss in Head Side (mm)

Bore size (mm)	G	Th9
12	1.5	15 ⁰ _{-0.043}
16	1.5	20 ⁰ _{-0.052}
20	2	13 ⁰ _{-0.043}
25	2	15 ⁰ _{-0.043}

Note) With boss in rod side : Option (Suffix "-XC36" to the end of part number.)

Rod end male thread

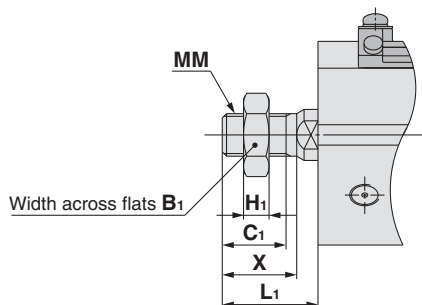

Rod End Male Thread (mm)

Bore size (mm)	B ₁	C ₁	H ₁	L ₁	MM	X
12	8	9	4	14	M5 x 0.8	10.5
16	10	10	5	15.5	M6 x 1.0	12
20	13	12	5	18.5	M8 x 1.25	14
25	17	15	6	22.5	M10 x 1.25	17.5

For the auto switch mounting position and its mounting height, refer to page 760 to 766.

Basic Style

Bore size (mm)	Stroke range (mm)	A	B	C	D	E	F	H	K	L	M	N	O	Q	S	U	V
12	5 to 30	31.5	28	6	6	32	6.5	M3 x 0.5	5	3.5	22	3.5	6.5 depth 3.5	11	36.5	20.5	25
16	5 to 30	34	30.5	8	8	38	5.5	M4 x 0.7	6	3.5	28	3.5	6.5 depth 3.5	10	42.5	23.5	29
20	5 to 50	36	31.5	7	10	47	5.5	M5 x 0.8	8	4.5	36	5.5	9 depth 7	10.5	49	25.5	36
25	5 to 50	37.5	32.5	12	12	52	5.5	M6 x 1.0	10	5	40	5.5	9 depth 7	11	54.5	28.5	40



Note 2) External dimensions with rubber bumper are same as standard type as shown above.

* For details about the rod end nut and accessory brackets, refer to page 620.

Note 3) For calculation on the longitudinal dimension of the intermediate strokes, refer to page 603.

Foot style: CDQ2L

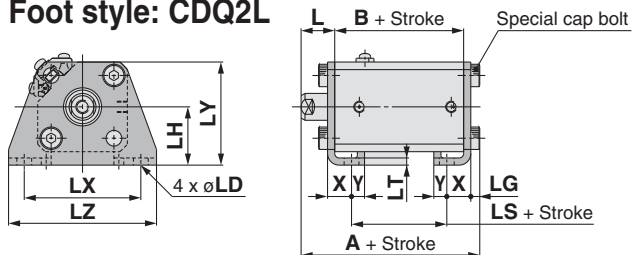

Rod end male thread

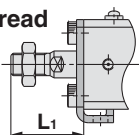

Rod side flange style: CDQ2F

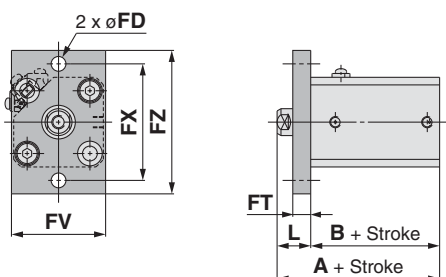

Rod end male thread

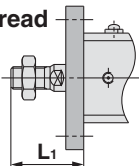

Head side flange style: CDQ2G

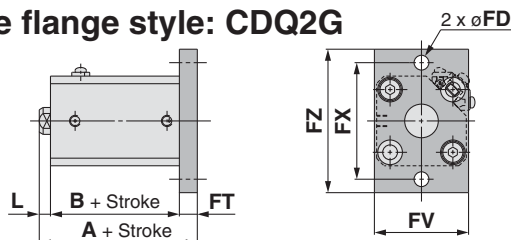

Rod end male thread

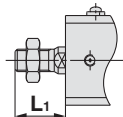

Double clevis style: CDQ2D

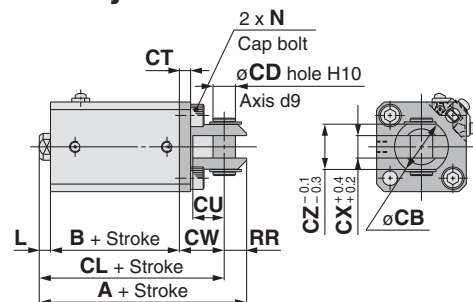

Rod end male thread

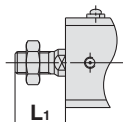

Foot Style

		(mm)													
Bore size (mm)	Stroke range (mm)	A	B	L	L ₁	LD	LG	LH	LS	LT	LX	LY	LZ	X	Y
12	5 to 30	46.3	28	13.5	24	4.5	2.8	17	16	2	34	29.5	44	8	4.5
16	5 to 30	48.8	30.5	13.5	25.5	4.5	2.8	19	18.5	2	38	33.5	48	8	5
20	5 to 50	53.2	31.5	14.5	28.5	6.6	4	24	19.5	3.2	48	42	62	9.2	5.8
25	5 to 50	54.7	32.5	15	32.5	6.6	4	26	17.5	3.2	52	46	66	10.7	5.8

Foot bracket material: Carbon steel
Surface treatment: Nickel plated

Rod Side Flange Style

		(mm)									
Bore size (mm)	Stroke range (mm)	A	B	FD	FT	FV	FX	FZ	L	L ₁	
12	5 to 30	41.5	28	4.5	5.5	25	45	55	13.5	24	
16	5 to 30	44	30.5	4.5	5.5	30	45	55	13.5	25.5	
20	5 to 50	46	31.5	6.6	8	39	48	60	14.5	28.5	
25	5 to 50	47.5	32.5	6.6	8	42	52	64	15	32.5	

Foot bracket material: Carbon steel
Surface treatment: Nickel plated

Head Side Flange Style

		(mm)		
Bore size (mm)	Stroke range (mm)	A	L	L ₁
12	5 to 30	37	3.5	14
16	5 to 30	39.5	3.5	15.5
20	5 to 50	44	4.5	18.5
25	5 to 50	45.5	5	22.5

Foot bracket material: Carbon steel
Surface treatment: Nickel plated

(* Dimensions except A, L and L₁ are the same as rod side flange style.)

CUJ

CU

CQS

CQ2

RQ

CQM

MU

Double Clevis Style

		(mm)													
Bore size (mm)	Stroke range (mm)	A	B	CB	CD	CL	CT	CU	CW	CX	CZ	L	L ₁	N	RR
12	5 to 30	51.5	28	12	5	45.5	4	7	14	5	10	3.5	14	M4 x 0.7	6
16	5 to 30	55	30.5	14	5	49	4	10	15	6.5	12	3.5	15.5	M4 x 0.7	6
20	5 to 50	63	31.5	20	8	54	5	12	18	8	16	4.5	18.5	M6 x 1.0	9
25	5 to 50	67.5	32.5	24	10	57.5	5	14	20	10	20	5	22.5	M6 x 1.0	10

Double clevis bracket material: Carbon steel
Surface treatment: Nickel plated

* For details about the rod end nut and accessory brackets, refer to page 620.
** Double clevis pins and retaining rings are included.

D-□

-X□

Individual

-X□

Technical data

Series CQ2

Dimensions

Ø32 to Ø50

Both ends tapped style: CQ2A/CDQ2A

Basic style (Through-hole): CQ2B/CDQ2B

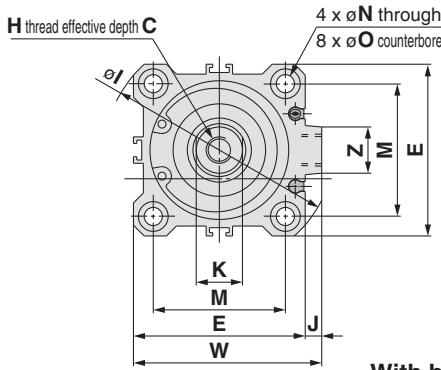

With boss in head side

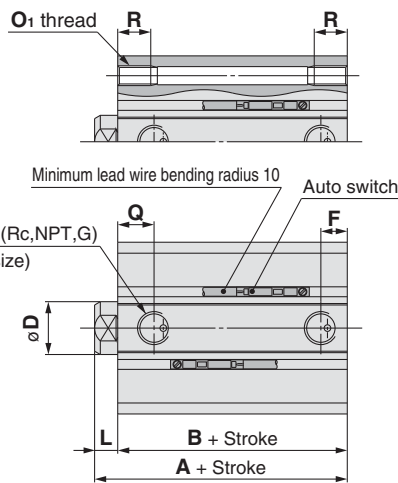

Rod end male thread

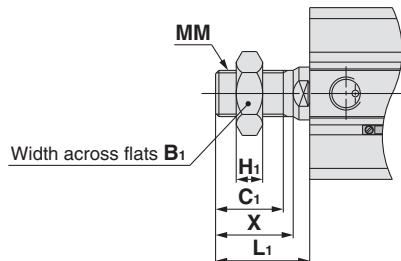

Both Ends Tapped Style (mm)

Bore size (mm)	O ₁	R
32	M6 x 1.0	10
40	M6 x 1.0	10
50	M8 x 1.25	14

With Boss in Head Side (mm)

Bore size (mm)	Th9
32	21 ⁰ _{-0.052}
40	28 ⁰ _{-0.052}
50	35 ⁰ _{-0.052}

Note 1) With boss in rod side : Option (Suffix "-XC36" to the end of part number.)

Rod End Male Thread (mm)

Bore size (mm)	B ₁	C ₁	H ₁	L ₁	MM	X
32	22	20.5	8	28.5	M14 x 1.5	23.5
40	22	20.5	8	28.5	M14 x 1.5	23.5
50	27	26	11	33.5	M18 x 1.5	28.5

Built-in One-touch fittings: Ø32 to Ø50

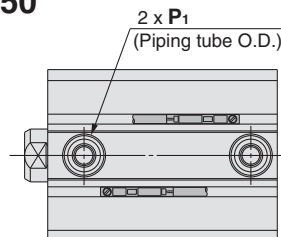
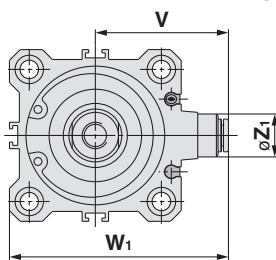

Built-in One-touch Fittings (mm)

Bore size (mm)	Z ₁	P ₁	V	W ₁
32	13	6	36.5	59
40	13	6	40.5	66
50	16	8	50	82

Basic Style

For the auto switch mounting position and its mounting height, refer to page 760 to 766.

Bore size (mm)	Stroke range (mm)	Without auto switch					With auto switch					C	D	E	H	I	J	K	L	M
		A	B	F	P	Q	A	B	F	P	Q									
32	5	30	23	5.5	M5 x 0.8	11.5	40	33	7.5	Rc1/8	10.5	13	16	45	M8 x 1.25	60	4.5	14	7	34
	10 to 50	40	33	7.5	1/8	10.5	40	33	7.5	Rc1/8	10.5	13	16	45	M8 x 1.25	60	4.5	14	7	34
	75, 100	40	33	7.5	1/8	10.5	40	33	7.5	Rc1/8	10.5	13	16	45	M8 x 1.25	60	4.5	14	7	34
40	5 to 50	36.5	29.5	8	1/8	11	46.5	39.5	8	Rc1/8	11	13	16	52	M8 x 1.25	69	5	14	7	40
	75, 100	46.5	39.5	8	1/8	11	46.5	39.5	8	Rc1/8	11	13	16	52	M8 x 1.25	69	5	14	7	40
	10 to 50	38.5	30.5	10.5	1/4	10.5	48.5	40.5	10.5	Rc1/4	10.5	15	20	64	M10 x 1.5	86	7	17	8	50
50	75, 100	48.5	40.5	10.5	1/4	10.5	48.5	40.5	10.5	Rc1/4	10.5	15	20	64	M10 x 1.5	86	7	17	8	50

Bore size (mm)	N	O	S	U	W	Z
32	5.5	9 depth 7	58.5	31.5	49.5	14
40	5.5	9 depth 7	66	35	57	14
50	6.6	11 depth 8	80	41	71	19



Note 2) External dimensions with rubber bumper are same as standard type as shown above.
 * For details about the rod end nut and accessory brackets, refer to page 620.
 Note 3) For calculation on the longitudinal dimension of the intermediate strokes, refer to page 603. Because we have the spacer-installed type and the exclusive body type (-X10).

Foot style: CQ2L/CDQ2L

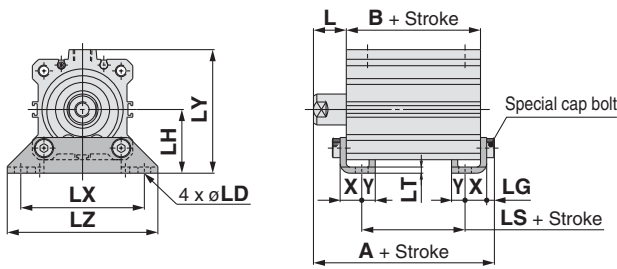

Rod end male thread

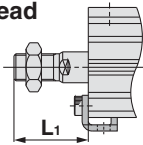

Rod side flange style: CQ2F/CDQ2F

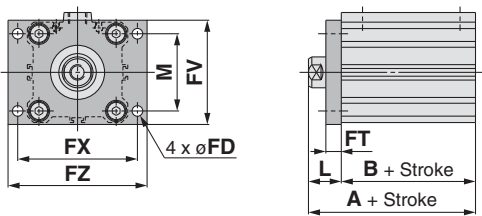

Rod end male thread

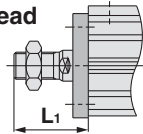

Head side flange style: CQ2G/CDQ2G

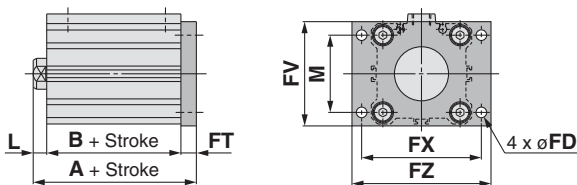

Rod end male thread

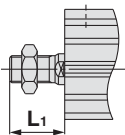

Double clevis style: CQ2D/CDQ2D

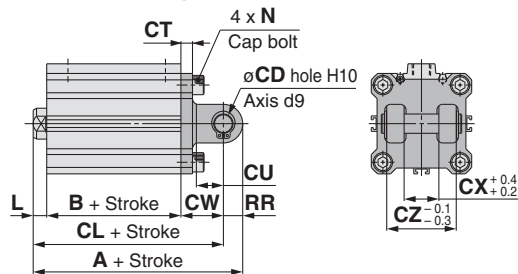

Rod end male thread

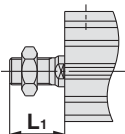

Foot Style

(mm)

Bore size (mm)	Stroke range (mm)	Without auto switch			With auto switch			L	L ₁	LD	LG	LH	LT	LX	LY
		A	B	LS	A	B	LS								
32	5 to 50	47.2	23	7	57.2	33	17	17	38.5	6.6	4	30	3.2	57	57
	75, 100	57.2	33	17											
40	5 to 50	53.7	29.5	13.5	63.7	39.5	23.5	17	38.5	6.6	4	33	3.2	64	64
	75, 100	63.7	39.5	23.5											
50	10 to 50	56.7	30.5	7.5	66.7	40.5	17.5	18	43.5	9	5	39	3.2	79	78
	75, 100	66.7	40.5	17.5											

Foot bracket material: Carbon steel
Surface treatment: Nickel plated

Bore size (mm)	LZ	X	Y
32	71	11.2	5.8
40	78	11.2	7
50	95	14.7	8

Rod Side Flange Style

(mm)

Bore size (mm)	Stroke range (mm)	Without auto switch		With auto switch		FD	FT	FV	FX	FZ	L	L ₁	M
		A	B	A	B								
32	5 to 50	40	23	50	33	5.5	8	48	56	65	17	38.5	34
	75, 100	50	33										
40	5 to 50	46.5	29.5	56.5	39.5	5.5	8	54	62	72	17	38.5	40
	75, 100	56.5	39.5										
50	10 to 50	48.5	30.5	58.5	40.5	6.6	9	67	76	89	18	43.5	50
	75, 100	58.5	40.5										

Foot bracket material: Carbon steel
Surface treatment: Nickel plated

Head Side Flange Style

(mm)

Bore size (mm)	Stroke range (mm)	Without auto switch	With auto switch	L	L ₁
		A	A		
32	5 to 50	38	48	7	28.5
	75, 100	48			
40	5 to 50	44.5	54.5	7	28.5
	75, 100	54.5			
50	10 to 50	47.5	57.5	8	33.5
	75, 100	57.5			

(* Dimensions except A, L and L₁ are the same as rod side flange style.)

Foot bracket material: Carbon steel
Surface treatment: Nickel plated

Double Clevis Style

(mm)

Bore size (mm)	Stroke range (mm)	Without auto switch			With auto switch			CD	CT	CU	CW	CX	CZ	L	L ₁
		A	B	CL	A	B	CL								
32	5 to 50	60	23	50	70	33	60	10	5	14	20	18	36	7	28.5
	75, 100	70	33	60											
40	5 to 50	68.5	29.5	58.5	78.5	39.5	68.5	10	6	14	22	18	36	7	28.5
	75, 100	78.5	39.5	68.5											
50	10 to 50	80.5	30.5	66.5	90.5	40.5	76.5	14	7	20	28	22	44	8	33.5
	75, 100	90.5	40.5	76.5											

Double clevis bracket material: Cast iron
Surface treatment: Painted

Bore size (mm)	N	RR
32	M6 x 1.0	10
40	M6 x 1.0	10
50	M8 x 1.25	14

* For details about the rod end nut and accessory brackets, refer to page 620.
** Double clevis pins and retaining rings are included.

CUJ

CU

CQS

CQ2

RQ

CQM

MU

D-□

-X□

Individual
-X□

Technical
data

Series CQ2

Dimensions

Ø63 to Ø100

Both ends tapped style: CQ2A/CDQ2A

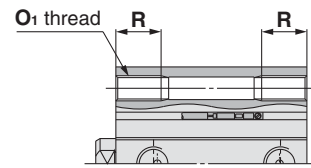

Both Ends Tapped Style (mm)

Bore size (mm)	O ₁	R
63	M10 x 1.5	18
80	M12 x 1.75	22
100	M12 x 1.75	22

Basic style (Through-hole)

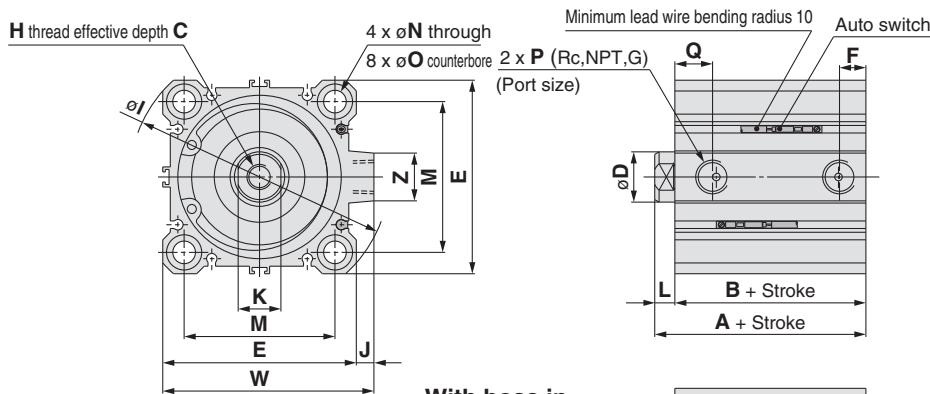

With boss in head side

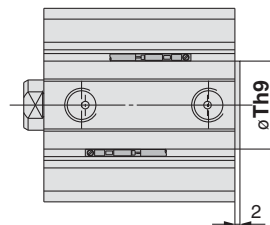

With Boss in Head Side (mm)

Bore size (mm)	Th9
63	35 ⁰ _{-0.052}
80	43 ⁰ _{-0.052}
100	59 ⁰ _{-0.052}

Note 1) With boss in rod side : Option (Suffix "-XC36" to the end of part number.)

Rod end male thread

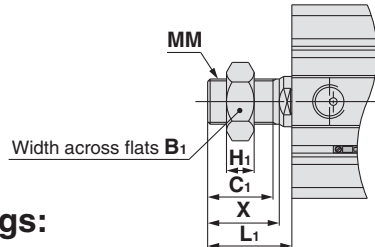

Rod End Male Thread (mm)

Bore size (mm)	B ₁	C ₁	H ₁	L ₁	MM	X
63	27	26	11	33.5	M18 x 1.5	28.5
80	32	32.5	13	43.5	M22 x 1.5	35.5
100	41	32.5	16	43.5	M26 x 1.5	35.5

Built-in One-touch fittings: Ø63 to Ø100

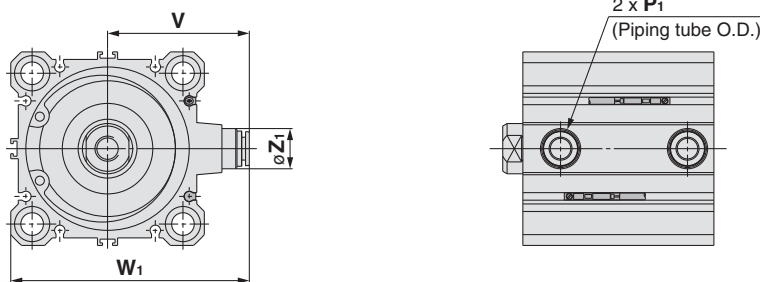

Built-in One-touch Fittings (mm)

Bore size (mm)	Z ₁	P ₁	V	W ₁
63	16	8	56.5	95

Basic Style For the auto switch mounting position and its mounting height, refer to page 760 to 766.

Bore size (mm)	Stroke range (mm)	Without auto switch		With auto switch		C	D	E	F	H	I	J	K	L	M	N	O	P	Q	S	
		A	B	A	B																
63	10 to 50	44	36	54	46	15	20	77	10.5	M10 x 1.5	103	7	17	8	60	9	14 depth	10.5	1/4	15	93
	75, 100	54	46																		
80	10 to 50	53.5	43.5	63.5	53.5	21	25	98	12.5	M16 x 2.0	132	6	22	10	77	11	17.5 depth	13.5	3/8	16	112.5
	75, 100	63.5	53.5																		
100	10 to 50	65	53	75	63	27	30	117	13	M20 x 2.5	156	6.5	27	12	94	11	17.5 depth	13.5	3/8	23	132.5
	75, 100	75	63																		

Bore size (mm)	U	W	Z
63	47.5	84	19
80	57.5	104	26
100	67.5	123.5	26



Note 2) External dimensions with rubber bumper are same as standard type as shown above.
* For details about the rod end nut and accessory brackets, refer to page 620.
Note 3) For calculation on the longitudinal dimension of the intermediate strokes, refer to page 603. Because we have the spacer-installed type and the exclusive body type (-X10).

Foot style: CQ2L/CDQ2L

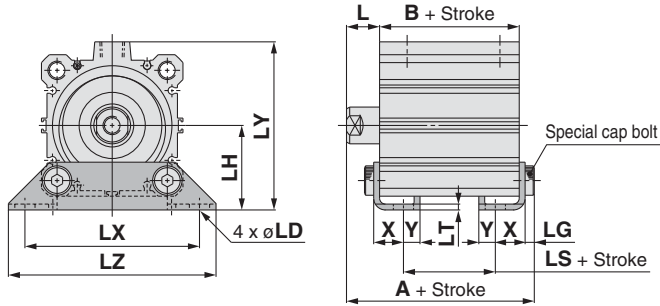

Rod end male thread

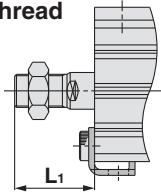

Rod side flange style: CQ2F/CDQ2F

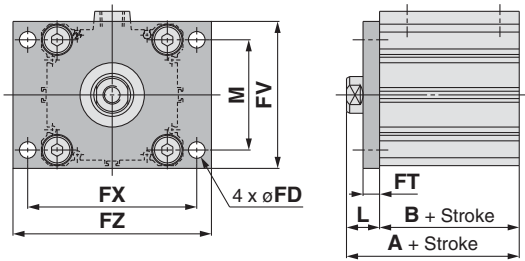

Rod end male thread

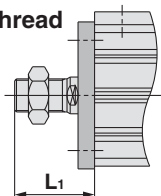

Foot Style

(mm)

Bore size (mm)	Stroke range (mm)	Without auto switch			With auto switch			L	L ₁	LD	LG	LH	LT
		A	B	LS	A	B	LS						
63	10 to 50	62.2	36	10	72.2	46	20	18	43.5	11	5	46	3.2
	75, 100	72.2	46	20									
80	10 to 50	75	43.5	13.5	85	53.5	23.5	20	53.5	13	7	59	4.5
	75, 100	85	53.5	23.5									
100	10 to 50	88	53	19	98	63	29	22	53.5	13	7	71	6
	75, 100	98	63	29									

Foot bracket material: Carbon steel
Surface treatment: Nickel plated

Bore size (mm)	Stroke range (mm)	LX	LY	LZ	X	Y
63	10 to 50	95	91.5	113	16.2	9
	75, 100					
80	10 to 50	118	114	140	19.5	11
	75, 100					
100	10 to 50	137	136	162	23	12.5
	75, 100					

Rod Side Flange Style

(mm)

Bore size (mm)	Stroke range (mm)	Without auto switch		With auto switch		FD	FT	FV	FX	FZ	L	L ₁	M
		A	B	A	B								
63	10 to 50	54	36	64	46	9	9	80	92	108	18	43.5	60
	75, 100	64	46										
80	10 to 50	63.5	43.5	73.5	53.5	11	11	99	116	134	20	53.5	77
	75, 100	73.5	53.5										
100	10 to 50	75	53	85	63	11	11	117	136	154	22	53.5	94
	75, 100	85	63										

Foot bracket material: Carbon steel
Surface treatment: Nickel plated

Head side flange style: CQ2G/CDQ2G

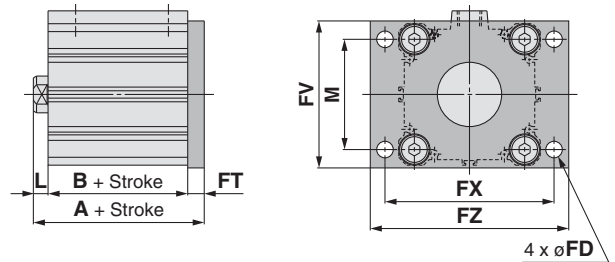

Rod end male thread

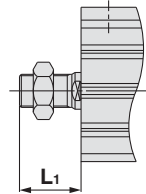

Double clevis style: CQ2D/CDQ2D

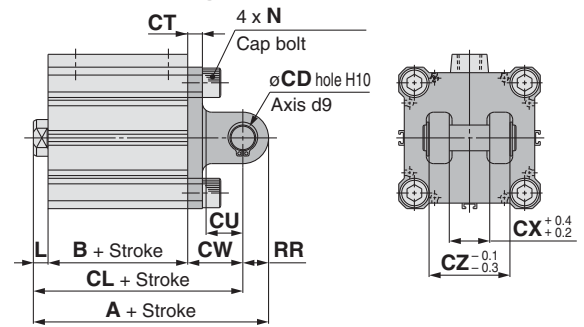

Rod end male thread

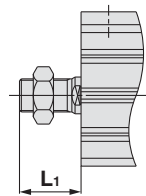

Head Side Flange Style

(mm)

Bore size (mm)	Stroke range (mm)	Without auto switch		With auto switch		L	L ₁
		A	A	A	A		
63	10 to 50	53	63	8	33.5		
	75, 100	63					
80	10 to 50	64.5	74.5	10	43.5		
	75, 100	74.5					
100	10 to 50	76	86	12	43.5		
	75, 100	86					

(* Dimensions except A, L and L₁ are the same as rod side flange style.)

Foot bracket material: Carbon steel Surface treatment: Nickel plated

Double Clevis Style

(mm)

Bore size (mm)	Stroke range (mm)	Without auto switch			With auto switch			CD	CT	CU	CW	CX
		A	B	CL	A	B	CL					
63	10 to 50	88	36	74	98	46	84	14	8	20	30	22
	75, 100	98	46	84								
80	10 to 50	109.5	43.5	91.5	119.5	53.5	101.5	18	10	27	38	28
	75, 100	119.5	53.5	101.5								
100	10 to 50	132	53	110	142	63	120	22	13	31	45	32
	75, 100	142	63	120								

Double clevis bracket material: Cast iron
Surface treatment: Painted

Bore size (mm)	Stroke range (mm)	CZ	L	L ₁	N	RR
63	10 to 50	44	8	33.5	M10 x 1.5	14
	75, 100					
80	10 to 50	56	10	43.5	M12 x 1.75	18
	75, 100					
100	10 to 50	64	12	43.5	M12 x 1.75	22
	75, 100					

* For details about the rod end nut and accessory brackets, refer to page 620.
** Double clevis pins and retaining rings are included.

Series CQ2

Accessory Bracket

Single Knuckle Joint

For I-G012, I-Z015A
I-G02, I-G03

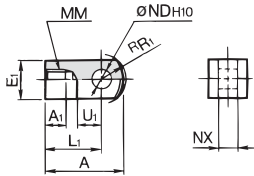

Material: Carbon steel
Surface treatment: Nickel plated

For I-G04, I-G05
I-G08, I-G10

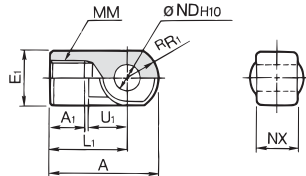

Material: Cast iron
Surface treatment: Nickel plated

Double Knuckle Joint

For Y-G012, Y-Z015A
Y-G02, Y-G03

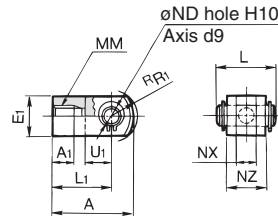

Material: Carbon steel
Surface treatment: Nickel plated

For Y-G04, Y-G05
Y-G08, Y-G10

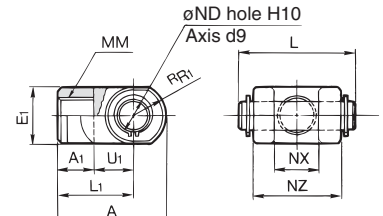

Material: Cast iron
Surface treatment: Nickel plated

(mm)

Part no.	Applicable bore size (mm)	A	A ₁	E ₁	L ₁	MM	R _{r1}	U ₁	ND _{H10}	NX
I-G012	12	21.5	6	□10	16	M5 x 0.8	6.3	7	5 ^{+0.048} ₀	5 ^{-0.2} _{-0.4}
I-Z015A	16	32	8	□12	25	M6 x 1	8.1	14	5 ^{+0.048} ₀	6.4 ^{-0.1} _{-0.3}
I-G02	20	34	8.5	□16	25	M8 x 1.25	10.3	11.5	8 ^{+0.058} ₀	8 ^{-0.2} _{-0.4}
I-G03	25	41	10.5	□20	30	M10 x 1.25	12.8	14	10 ^{+0.058} ₀	10 ^{-0.2} _{-0.4}
I-G04	32,40	42	14	∅22	30	M14 x 1.5	12	14	10 ^{+0.058} ₀	18 ^{-0.3} _{-0.5}
I-G05	50,63	56	18	∅28	40	M18 x 1.5	16	20	14 ^{+0.070} ₀	22 ^{-0.3} _{-0.5}
I-G08	80	71	21	∅38	50	M22 x 1.5	21	27	18 ^{+0.070} ₀	28 ^{-0.3} _{-0.5}
I-G10	100	79	21	∅44	55	M26 x 1.5	24	31	22 ^{+0.084} ₀	32 ^{-0.3} _{-0.5}

(mm)

Part no.	Applicable bore size (mm)	A	A ₁	E ₁	L ₁	MM	R _{r1}	U ₁	ND _{H10}	NX	NZ	L	Applicable pin part no.
Y-G012	12	21.5	6	□10	16	M5 x 0.8	6.3	7	5 ^{+0.048} ₀	5 ^{+0.4} _{+0.2}	10	14.6	IY-G012
Y-Z015A	16	28	11	□12	21	M6 x 1	8.1	10	5 ^{+0.048} ₀	6.5 ^{+0.2} ₀	12	16.6	IY-J015
Y-G02	20	34	8.5	□16	25	M8 x 1.25	10.3	11.5	8 ^{+0.058} ₀	8 ^{+0.4} _{+0.2}	16	21	IY-G02
Y-G03	25	41	10.5	□20	30	M10 x 1.25	12.8	14	10 ^{+0.058} ₀	10 ^{+0.4} _{+0.2}	20	25.6	IY-G03
Y-G04	32,40	42	16	∅22	30	M14 x 1.5	12	14	10 ^{+0.058} ₀	18 ^{+0.5} _{+0.3}	36	41.6	IY-G04
Y-G05	50,63	56	20	∅28	40	M18 x 1.5	16	20	14 ^{+0.070} ₀	22 ^{+0.5} _{+0.3}	44	50.6	IY-G05
Y-G08	80	71	23	∅38	50	M22 x 1.5	21	27	18 ^{+0.070} ₀	28 ^{+0.5} _{+0.3}	56	64	IY-G08
Y-G10	100	79	24	∅44	55	M26 x 1.5	24	31	22 ^{+0.084} ₀	32 ^{+0.5} _{+0.3}	64	72	IY-G10

* Knuckle pin and retaining ring are included.

Knuckle Pin (Common with double clevis pin)

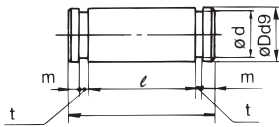

Material: Carbon steel

(mm)

Part no.	Applicable bore size (mm)	Dd9	L	d	l	m	t	Applicable snap ring
IY-G012	12	5 ^{-0.030} _{-0.060}	14.6	4.8	10.2	1.5	0.7	Type C 5 for axis
IY-J015	16	5 ^{-0.030} _{-0.060}	16.6	4.8	12.2	1.5	0.7	Type C 5 for axis
IY-G02	20	8 ^{-0.040} _{-0.076}	21	7.6	16.2	1.5	0.9	Type C 8 for axis
IY-G03	25	10 ^{-0.040} _{-0.076}	25.6	9.6	20.2	1.55	1.15	Type C 10 for axis
IY-G04	32,40	10 ^{-0.040} _{-0.076}	41.6	9.6	36.2	1.55	1.15	Type C 10 for axis
IY-G05	50,63	14 ^{-0.050} _{-0.093}	50.6	13.4	44.2	2.05	1.15	Type C 14 for axis
IY-G08	80	18 ^{-0.050} _{-0.093}	64	17	56.2	2.55	1.35	Type C 18 for axis
IY-G10	100	22 ^{-0.065} _{-0.117}	72	21	64.2	2.55	1.35	Type C 22 for axis

* Type C retaining rings for axis are included.

Rod End Nut

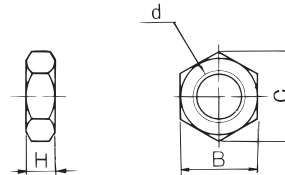

Material: Carbon steel
Surface treatment: Nickel plated

(mm)

Part no.	Applicable bore size (mm)	d	H	B	C
NTJ-015A	12	M5 x 0.8	4	8	9.2
NT-015A	16	M6 x 1	5	10	11.5
NT-02	20	M8 x 1.25	5	13	15.0
NT-03	25	M10 x 1.25	6	17	19.6
NT-04	32,40	M14 x 1.5	8	22	25.4
NT-05	50,63	M18 x 1.5	11	27	31.2
NT-08	80	M22 x 1.5	13	32	37.0
NT-10	100	M26 x 1.5	16	41	47.3

Simple Joint: $\phi 32$ to $\phi 100$

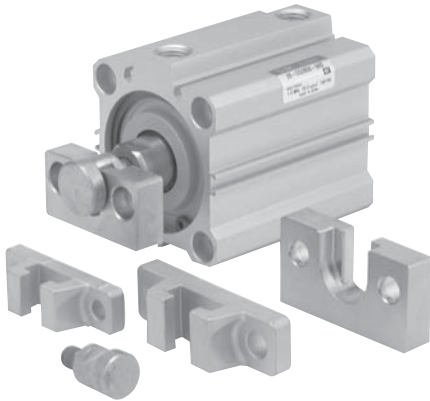

Type A Mounting Bracket

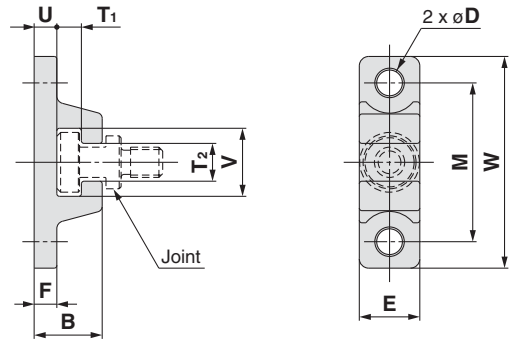

Material: Chromium molybdenum steel (Nickel plated)
(mm)

**Joint and Mounting Bracket
(Type A, Type B) Part No.**

YA - 03

- Mounting bracket
 - Applicable air cylinder bore
- | | |
|-----------|-------------------------|
| YA | Type A mounting bracket |
| YB | Type B mounting bracket |
| YU | Joint |
- | | |
|-----------|------------------------|
| 03 | For $\phi 32, \phi 40$ |
| 05 | For $\phi 50, \phi 63$ |
| 08 | $\phi 80$ |
| 10 | $\phi 100$ |

Part no.	Bore size (mm)	B	D	E	F	M	T ₁	T ₂
YA-03	32, 40	18	6.8	16	6	42	6.5	10
YA-05	50, 63	20	9	20	8	50	6.5	12
YA-08	80	26	11	25	10	62	8.5	16
YA-10	100	31	14	30	12	76	10.5	18

Part no.	Bore size (mm)	U	V	W	Mass (g)
YA-03	32, 40	6	18	56	55
YA-05	50, 63	8	22	67	100
YA-08	80	10	28	83	195
YA-10	100	12	36	100	340

Allowable Eccentricity (mm)

Bore size (mm)	$\phi 32$	$\phi 40$	$\phi 50$	$\phi 63$	$\phi 80$	$\phi 100$
Eccentricity tolerance	± 1			± 1.5		
Backlash	0.5					

<Ordering>

- Joints are not included with the A or B type mounting brackets. Order them separately.

(Example)

- Bore size $\phi 40$ Part no.
- Type A mounting bracket part no. YA-03
- Joint YU-03

Joint and Mounting Bracket (Type A, Type B) Part No.

Bore size (mm)	Joint part no.	Applicable mounting bracket	
		Type A mounting bracket	Type B mounting bracket
32, 40	YU-03	YA-03	YB-03
50, 63	YU-05	YA-05	YB-05
80	YU-08	YA-08	YB-08
100	YU-10	YA-10	YB-10

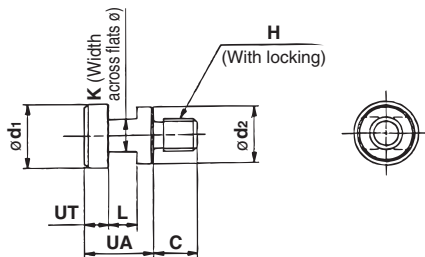

Material: Chromium molybdenum steel (Nickel plated)
(mm)

Part no.	Applicable bore size (mm)	UA	C	d ₁	d ₂	H	K	L	UT	Mass (g)
YU-03	32, 40	17	11	15.8	14	M8 x 1.25	8	7	6	25
YU-05	50, 63	17	13	19.8	18	M10 x 1.5	10	7	6	40
YU-08	80	22	20	24.8	23	M16 x 2	13	9	8	90
YU-10	100	26	26	29.8	28	M20 x 2.5	14	11	10	160

Type B Mounting Bracket

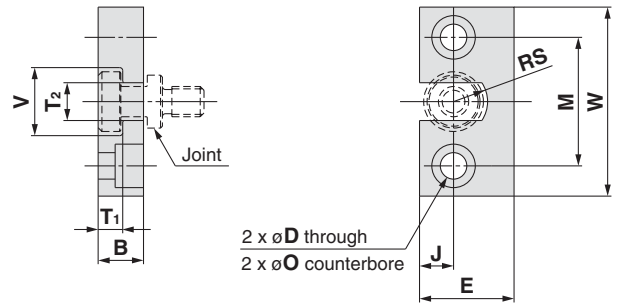

Material: Stainless steel
(mm)

Part no.	Bore size (mm)	B	D	E	J	M	ϕO
YB-03	32, 40	12	7	25	9	34	11.5 depth 7.5
YB-05	50, 63	12	9	32	11	42	14.5 depth 8.5
YB-08	80	16	11	38	13	52	18 depth 12
YB-10	100	19	14	50	17	62	21 depth 14

Part no.	Bore size (mm)	T ₁	T ₂	V	W	RS	Mass (g)
YB-03	32, 40	6.5	10	18	50	9	80
YB-05	50, 63	6.5	12	22	60	11	120
YB-08	80	8.5	16	28	75	14	230
YB-10	100	10.5	18	36	90	18	455

- CUJ
- CU
- CQS
- CQ2**
- RQ
- CQM
- MU

- D-□
- X□
- Individual -X□
- Technical data

Compact Cylinder/*Series CQ2* With Auto Switch 1

1 Proper Auto Switch Mounting Position (Detection at stroke end) and Mounting Height

Applicable cylinder series: CDQ2, CDQ2W, CDQ2□□□-□S/-□T (Single acting), CDQ2K, CDQ2KW (Non-rotating), CDQP2, CDQP2□□□-□S/-□T (Axial piping), CDQ2 (Long stroke), CDQ2□S (Anti-lateral load), CDBQ2 (End lock), CDQ2□R/□V (Water resistant)

D-A9□
D-M9□
D-M9□W
D-M9□AL
D-A9□V
D-M9□V
D-M9□WV
D-M9□AVL

∅12 to ∅25

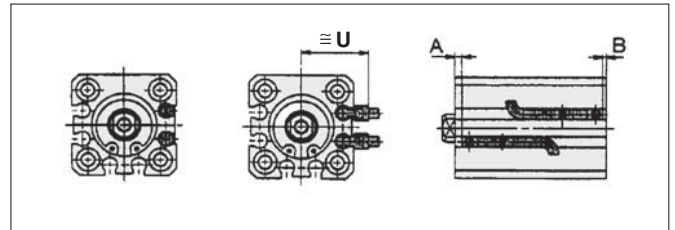
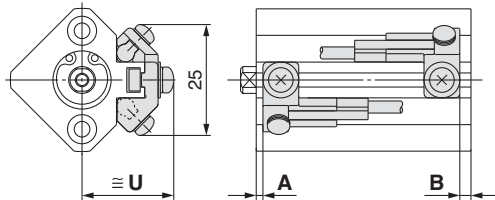

CDBQ2 (End lock, ∅20, ∅25)

∅32 to ∅100

D-A9□
D-M9□
D-M9□W
D-M9□AL

D-A9□V
D-M9□V
D-M9□WV
D-M9□AVL

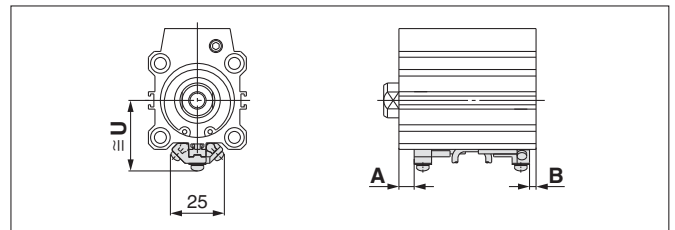
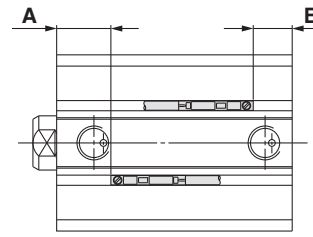
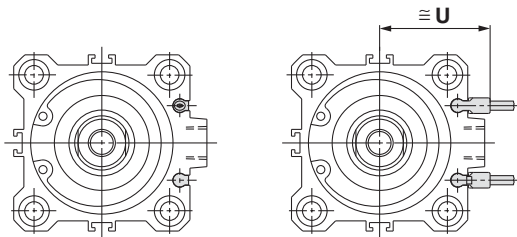

CDQP2, CDQP2□□□-□S/-□T (∅32 to ∅100)

D-A7□
D-A80
D-A7□H
D-A80H
D-F7□
D-J79
D-F7□W
D-J79W
D-F79F

D-F7NTL
D-F7BAL
D-A73C
D-A80C
D-J79C
D-A79W
D-F7□WV
D-J7□V
D-F7BAVL

∅12 to ∅25

∅32 to ∅100

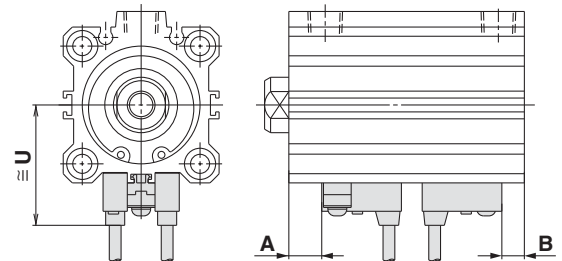
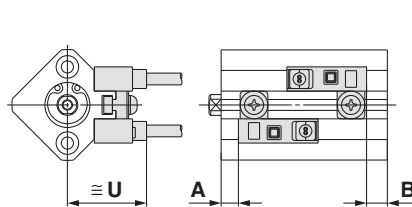

D-P4DWL

∅40 to ∅100

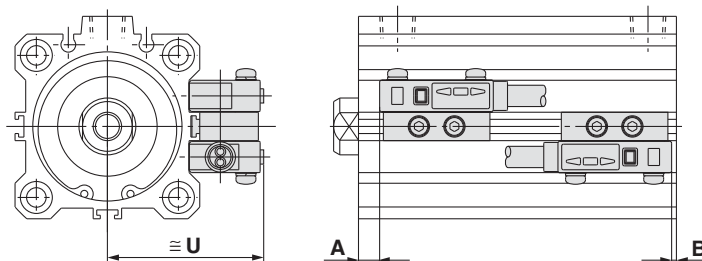

Proper Auto Switch Mounting Position

Applicable Cylinder Series: CDQ2 (Double acting, Single rod)

(mm)

Auto switch model Bore size	D-A9□ D-A9□V		D-M9□ D-M9□V D-M9□W D-M9□WV D-M9□AL D-M9□AVL		D-A73 D-A80		D-A72/A7□H/A80H D-A73C/A80C/F7□ D-F79F/J79/F7□V D-J79C/F7□W D-J79W/F7□WV D-F7BAVL/F7BAL		D-F7NTL		D-A79W		D-P4DWL	
	A	B	A	B	A	B	A	B	A	B	A	B	A	B
12	2	3	6	7	4.5	5.5	5	6	10	11	2	3	—	—
16	5	2.5	9	6.5	7.5	5	8	5.5	13	10.5	5	2.5	—	—
20	5	3.5	9	7.5	7.5	6.5	8	7	13	12	5	4	—	—
25	5.5	4	9.5	8	7.5	7	8	7.5	13	12.5	5	4.5	—	—
32	8	5	12	9	9	6	9.5	6.5	14.5	11.5	6.5	3.5	—	—
40	12	7.5	16	11.5	13	8.5	13.5	9	18.5	14	10.5	6	9	4.5
50	10	10.5	14	14.5	11	11.5	11.5	12	16.5	17	8.5	9	7	7.5
63	12.5	13.5	16.5	17.5	13.5	14.5	14	15	19	20	11	12	9.5	10.5
80	16.5	17	20.5	21	17.5	18	18	18.5	23	23.5	15	15.5	13.5	14
100	20	23	24	27	21	24	21.5	24.5	26.5	29.5	18.5	21.5	17	20

Applicable Cylinder Series: CDQ2W (Double acting, Double rod)

(mm)

Auto switch model Bore size	D-A9□ D-A9□V		D-M9□ D-M9□V D-M9□W D-M9□WV D-M9□AL D-M9□AVL		D-A73 D-A80		D-A72/A7□H/A80H D-A73C/A80C/F7□ D-F79F/J79/F7□V D-J79C/F7□W D-J79W/F7□WV D-F7BAVL/F7BAL		D-F7NTL		D-A79W		D-P4DWL	
	A	B	A	B	A	B	A	B	A	B	A	B	A	B
12	2	7	6	11	4.5	10	5	10.5	10	15.5	2	7.5	—	—
16	5	8	9	12	7.5	10.5	8	11	13	16	5	8	—	—
20	5	10	9	14	7.5	13	8	13.5	13	18.5	5	10.5	—	—
25	5.5	10.5	9.5	14.5	7.5	13	8	13.5	13	18.5	5	10.5	—	—
32	8	12.5	12	16.5	9	13.5	9.5	14	14.5	19	6.5	11	—	—
40	12	18	16	22	13	19	13.5	19.5	18.5	24.5	10.5	16.5	9	15
50	10	20.5	14	24.5	11	21.5	11.5	22	16.5	27	8.5	19	7	17.5
63	12.5	19.5	16.5	23.5	13.5	20.5	14	21	19	26	11	18	9.5	16.5
80	16.5	28	20.5	32	17.5	29	18	29.5	23	34.5	15	26.5	13.5	25
100	20	30.5	24	34.5	21	31.5	21.5	32	26.5	37	18.5	29	17	27.5

CUJ

CU

CQS

CQ2

RQ

CQM

MU

Applicable Cylinder Series: CDQ2□□□□□S/□T (Single acting)

(mm)

Auto switch model Bore size	D-A9□ D-A9□V		D-M9□ D-M9□V D-M9□W D-M9□WV D-M9□AL D-M9□AVL		D-A73 D-A80		D-A72/A7□H/A80H D-A73C/A80C/F7□ D-F79F/J79/F7□V D-J79C/F7□W D-J79W/F7□WV D-F7BAVL/F7BAL		D-F7NTL		D-A79W	
	A	B	A	B	A	B	A	B	A	B	A	B
12	2	3 (7.5)	6	7 (11.5)	4.5	5.5 (10)	5	6 (10.5)	10	11 (15.5)	2	3 (7.5)
16	5 (3)	2.5 (4.5)	9 (7)	6.5 (8.5)	7.5 (5.5)	5 (7)	8 (6)	5.5 (7.5)	13 (11)	10.5 (12.5)	5 (3)	2.5 (4.5)
20	5	3.5	9	7.5	7.5	6.5	8	7	13	12	5	4
25	5.5	4	9.5	8	7.5	7	8	7.5	13	12.5	5	4.5
32	8	5	12	9	9	6	9.5	6.5	14.5	11.5	6.5	3.5
40	12	7.5	16	11.5	13	8.5	13.5	9	18.5	14	10.5	6
50	10	10.5	14	14.5	11	11.5	11.5	12	16.5	17	8.5	9

() : For the spring extend type

Note) Adjust the auto switch after confirming the operating conditions in the actual setting.

D-□

-X□

Individual
-X□

Technical
data

Compact Cylinder/*Series CQ2* With Auto Switch 2

1 Proper Auto Switch Mounting Position (Detection at stroke end) and Mounting Height

Proper Auto Switch Mounting Position

Applicable Cylinder Series: CDQ2K (Non-rotating)

(mm)

Auto switch model Bore size	D-A9□ D-A9□V		D-M9□ D-M9□V D-M9□W D-M9□WV D-M9□AL D-M9□AVL		D-A73 D-A80		D-A72/A7□H/A80H D-A73C/A80C/F7□ D-F79F/J79/F7□V D-J79C/F7□W D-J79W/F7□WV D-F7BAVL/F7BAL		D-F7NTL		D-A79W		D-P4DWL	
	A	B	A	B	A	B	A	B	A	B	A	B	A	B
12	7	3	11	7	9.5	5.5	10	6	15	11	7	3	—	—
16	10	2.5	14	6.5	12.5	5	13	5.5	18	10.5	10	2.5	—	—
20	13	3.5	17	7.5	15.5	6.5	16	7	21	12	13	4	—	—
25	13.5	4	17.5	8	15.5	7	16	7.5	21	12.5	13	4.5	—	—
32	17	5	21	9	18	6	18.5	6.5	23.5	11.5	15.5	3.5	—	—
40	12	7.5	16	11.5	13	8.5	13.5	9	18.5	14	10.5	6	9	4.5
50	10	10.5	14	14.5	11	11.5	11.5	12	16.5	17	8.5	9	7	7.5
63	12.5	13.5	16.5	17.5	13.5	14.5	14	15	19	20	11	12	9.5	10.5

Applicable Cylinder Series: CDQ2KW

(mm)

Auto switch model Bore size	D-A9□ D-A9□V		D-M9□ D-M9□V D-M9□W D-M9□WV D-M9□AL D-M9□AVL		D-A73 D-A80		D-A72/A7□H/A80H D-A73C/A80C/F7□ D-F79F/J79/F7□V D-J79C/F7□W D-J79W/F7□WV D-F7BAVL/F7BAL		D-F7NTL		D-A79W		D-P4DWL	
	A	B	A	B	A	B	A	B	A	B	A	B	A	B
12	7.5	7	11.5	11	9.5	10	10	10.5	15	15.5	7	7.5	—	—
16	10	8	14	12	12.5	10.5	13	11	18	16	10	8	—	—
20	13	10	17	14	15.5	13	16	13.5	21	18.5	13	10.5	—	—
25	13.5	10.5	17.5	14.5	15.5	13	16	13.5	21	18.5	13	10.5	—	—
32	17	12.5	21	16.5	18	13.5	18.5	14	23.5	19	15.5	11	—	—
40	12	18	16	22	13	19	13.5	19.5	18.5	24.5	10.5	16.5	9	15
50	10	20.5	14	24.5	11	21.5	11.5	22	16.5	27	8.5	19	7	17.5
63	12.5	19.5	16.5	23.5	13.5	20.5	14	21	19	26	11	18	9.5	16.5

Applicable Cylinder Series: CDQP2 (Axial piping)

(mm)

Auto switch model Bore size	D-A9□ D-A9□V		D-M9□ D-M9□V D-M9□W D-M9□WV D-M9□AL D-M9□AVL		D-A73 D-A80		D-A72/A7□H/A80H D-A73C/A80C/F7□ D-F79F/J79/F7□V D-J79C/F7□W D-J79W/F7□WV D-F7BAVL/F7BAL		D-F7NTL		D-A79W		D-P4DWL	
	A	B	A	B	A	B	A	B	A	B	A	B	A	B
12	2	3	6	7	4.5	5.5	5	6	10	11	2	3	—	—
16	5	2.5	9	6.5	7.5	5	8	5.5	13	10.5	5	2.5	—	—
20	5	3.5	9	7.5	7.5	6.5	8	7	13	12	5	4	—	—
25	5.5	4	9.5	8	7.5	7	8	7.5	13	12.5	5	4.5	—	—
32	6.5	3.5	10.5	7.5	9	6	9.5	6.5	14.5	11.5	6.5	3.5	—	—
40	10.5	6	14.5	10	13	8.5	13.5	9	18.5	14	10.5	6	9	4.5
50	8.5	9	12.5	13	11	11.5	11.5	12	16.5	17	8.5	9	7	7.5
63	11	12	15	16	13.5	14.5	14	15	19	20	11	12	9.5	10.5
80	14	16.5	18	20.5	17.5	18	18	18.5	23	23.5	15	15.5	13.5	14
100	18.5	21.5	22.5	25.5	21	24	21.5	24.5	26.5	29.5	18.5	21.5	17	20

Note) Adjust the auto switch after confirming the operating conditions in the actual setting.

Applicable Cylinder Series: CDQP2□□□-□S/□T (Axial piping, Single acting)

(mm)

Auto switch model	D-A9□ D-A9□V		D-M9□ D-M9□V D-M9□W D-M9□WV D-M9□AL D-M9□AVL		D-A73 D-A80		D-A72/A7□H/A80H D-A73C/A80C/F7□ D-F79F/J79/F7□V D-J79C/F7□W D-J79W/F7□WV D-F7BAVL/F7BAL		D-F7NTL		D-A79W	
	A	B	A	B	A	B	A	B	A	B	A	B
Bore size												
12	2	3 (7)	6	7 (11)	4.5	5.5 (10)	5	6 (10.5)	10	11 (15.5)	2	3 (7.5)
16	5 (3)	2.5 (4.5)	9 (7)	6.5 (8.5)	7.5 (5.5)	5 (7)	8 (6)	5.5 (7.5)	13 (11)	10.5 (12.5)	5 (3)	2.5 (4.5)
20	5	3.5	9	7.5	7.5	6.5	8	7	13	12	5	4
25	5.5	4	9.5	8	7.5	7	8	7.5	13	12.5	5	4.5
32	6.5	3.5	10.5	7.5	9	6	9.5	6.5	14.5	11.5	6.5	3.5
40	10.5	6	14.5	10	13	8.5	13.5	9	18.5	14	10.5	6
50	8.5	9	12.5	13	11	11.5	11.5	12	16.5	17	8.5	9

(): For the spring extend type

Applicable Cylinder Series: CDQ2 (Long stroke)

(mm)

Auto switch model	D-A9□ D-A9□V		D-M9□ D-M9□V D-M9□W D-M9□WV D-M9□AL D-M9□AVL		D-A73 D-A80		D-A72/A7□H/A80H D-A73C/A80C/F7□ D-F79F/J79/F7□V D-J79C/F7□W D-J79W/F7□WV D-F7BAVL/F7BAL		D-F7NTL		D-A79W		D-P4DWL	
	A	B	A	B	A	B	A	B	A	B	A	B	A	B
Bore size														
32	8.5	16.5	12.5	20.5	9.5	17.5	10	18	15	23	7	15	—	—
40	12	22.5	16	26.5	13	23.5	13.5	24	18.5	29	10.5	21	9	19.5
50	10	23	14	27	11	24	11.5	24.5	16.5	29.5	8.5	21.5	7	20
63	12.5	24.5	16.5	28.5	13.5	25.5	14	26	19	31	11	23	9.5	21.5
80	15.5	30.5	19.5	34.5	16.5	31.5	17	32	22	37	14	29	12.5	29.5
100	18.5	37	22.5	41	19.5	38	20	38.5	25	43.5	17	35.5	15.5	34

CUJ

CU

CQS

CQ2

RQ

CQM

MU

Applicable Cylinder Series: CDQ2□S (Anti-lateral load)

(mm)

Auto switch model	D-A9□ D-A9□V		D-M9□ D-M9□V D-M9□W D-M9□WV D-M9□AL D-M9□AVL		D-A73 D-A80		D-A72/A7□H/A80H D-A73C/A80C/F7□ D-F79F/J79/F7□V D-J79C/F7□W D-J79W/F7□WV D-F7BAVL/F7BAL		D-F7NTL		D-A79W		D-P4DWL	
	A	B	A	B	A	B	A	B	A	B	A	B	A	B
Bore size														
32	14	9	18	13	15	10	15.5	10.5	20.5	15.5	12.5	7.5	—	—
40	17.5	12	21.5	16	18.5	13	19	13.5	24	18.5	16	10.5	14.5	9
50	15	15.5	19	19.5	16	16.5	16.5	17	21.5	22	13.5	14	12	12.5
63	17.5	18.5	21.5	22.5	18.5	19.5	19	20	24	25	16	17	14.5	15.5
80	20.5	23	24.5	27	21.5	24	22	24.5	27	29.5	19	21.5	17.5	20
100	23.5	29.5	27.5	33.5	24.5	30.5	25	31	30	36	22	28	20.5	26.5

Note) Adjust the auto switch after confirming the operating conditions in the actual setting.

D-□

-X□

Individual
-X□

Technical
data

Compact Cylinder/*series CQ2* With Auto Switch 3

1 Proper Auto Switch Mounting Position (Detection at stroke end) and Mounting Height

Auto Switch Mounting Height

Applicable Cylinder Series: CDBQ2 (End lock)

(mm)

Auto switch model Bore size	D-A7□ D-A80		D-A7□H/A80H D-A73C/A80C D-F7□/J79/J79W D-F7□V/J79C D-F7□W/F7□WV D-F7BAL/F7BAVL D-F79F		D-A79W		D-A9□ D-A9□V		D-M9□ D-M9□V D-M9□W D-M9□WV D-M9□AL D-M9□AVL		D-P4DWL	
	A	B	A	B	A	B	A	B	A	B	A	B
20 (Head end lock)	—	—	—	—	—	—	6 (11)	35 (35)	10 (15)	39 (39)	—	—
20 (Rod end lock)	—	—	—	—	—	—	31.5 (34)	3 (12)	35.5 (38)	7 (16)	—	—
25 (Head end lock)	—	—	—	—	—	—	8 (10)	37 (39)	12 (14)	41 (43)	—	—
25 (Rod end lock)	—	—	—	—	—	—	32 (35)	5.5 (14)	36 (39)	9.5 (18)	—	—
32 (Head end lock)	9	38.5	9.5	39	6.5	36	8	37.5	12	41.5	—	—
32 (Rod end lock)	36	4	36.5	4.5	33.5	1.5	35	3	39	7	—	—
40 (Head end lock)	13	44	13.5	44.5	10.5	41.5	12	43	16	47	9	40
40 (Rod end lock)	42	4.5	42.5	5	39.5	2	41	3.5	45	7.5	38	0.5
50 (Head end lock)	11	46.5	11.5	47	8.5	44	10	45.5	14	49.5	7	42.5
50 (Rod end lock)	41.5	6	42	6.5	39	3.5	40.5	5	44.5	9	37.5	2
63 (Head end lock)	13.5	45.5	14	46	11	43	12.5	44.5	16.5	48.5	9.5	41.5
63 (Rod end lock)	45.5	7.5	46	8	43	5	44.5	6.5	48.5	10.5	41.5	3.5
80 (Head end lock)	16.5 (21.5)	76.5 (76.5)	17 (22)	77 (77)	14 (19)	74 (74)	15.5 (20.5)	75.5 (75.5)	19.5 (24.5)	79.5 (79.5)	12.5 (17.5)	72.5 (72.5)
80 (Rod end lock)	66.5 (66.5)	19 (31.5)	67 (67)	19.5 (32)	64 (64)	16.5 (29)	65.5 (65.5)	18 (30.5)	69.5 (69.5)	22 (34.5)	62.5 (62.5)	15 (27.5)
100 (Head end lock)	21 (26)	81.5 (81.5)	21.5 (26.5)	82 (82)	18.5 (23.5)	79 (79)	20 (25)	80.5 (80.5)	24 (29)	84.5 (84.5)	17 (22)	77.5 (77.5)
100 (Rod end lock)	71 (69.5)	24 (38)	71.5 (70)	24.5 (38.5)	68.5 (67)	21.5 (35.5)	70 (68.5)	23 (37)	74 (72.5)	27 (41)	67 (65.5)	20 (34)

Note) Dimensions in parentheses for ø20 and ø25 are for 50, 75 and 100 strokes, and dimensions in parentheses for ø80 and ø100 are for 75 and 100 strokes.

Applicable Cylinder Series: CDQ2□R/□V (Water resistant) (mm)

Auto switch model Bore size	D-M9□AL D-M9□AVL		D-F7BAL D-F7BAVL	
	A	B	A	B
20	19	7.5	18	7
25	19.5	8	18	7.5
32	22	9	19.5	6.5
40	16	11.5	13.5	9
50	14	14.5	11.5	12
63	16.5	17.5	14	15
80	20.5	21	18	18.5
100	24	27	21.5	24.5

Note) Adjust the auto switch after confirming the operating conditions in the actual setting.

Applicable Cylinder Series: CDQ2, CDQ2W, CDQ2□□□-□S/-□T (Single acting), CDQ2K, CDQ2KW (Non-rotating), CDQ2 (Long stroke), CDQ2□S (Anti-lateral load), CDQ2□R/□V (Water resistant) (mm)

Auto switch model	D-A9□V	D-M9□V D-M9□WV D-M9□AVL	D-A7□ D-A80	D-A7□H A80H D-F7□ D-J79 D-F7□W D-J79W D-F7BAL D-F79F D-F7NTL	D-A73C D-A80C	D-F7□V D-F7□WV D-F7BAVL	D-J79C	D-A79W	D-P4DWL
	U	U	U	U	U	U	U	U	U
12	20.5	20.5	19.5	20.5	26.5	23	26	22	—
16	23.5	23.5	22.5	23.5	29.5	26	29	25	—
20	25.5	25.5	24.5	25.5	31.5	28	31	27	—
25	28.5	28.5	27.5	28.5	34.5	31	34	30	—
32	27	29	31.5	32.5	38.5	35	38	34	—
40	30.5	32.5	35	36	42	38.5	41.5	37.5	44
50	36.5	38.5	41	42	48	44.5	47.5	43.5	50
63	40	42	47.5	48.5	54.5	51	54	50	56.5
80	50	52	57.5	58.5	64.5	61	64	60	66.5
100	60	62	67.5	68.5	74.5	71	74	70	76.5

* Except for a bore size over ø32 of D-A9□(V)/M9□(V)/M9□W(V)/M9□A(V)L types, the values above are measured when the conventional switch installation groove is attached without using the auto switch mounting bracket BQ2-012.

* The auto switch mounting height when BQ2-012 is used is the same as CDQP2 (axial piping) shown below.

* The applicable auto switches for CDQ2□R/□V (water resistant) are D-M9□A(V)L and F7BA(V)L.

Applicable Cylinder Series: CDQP2, CDQP2□□□-□S/-□T (Axial piping) (mm)

Auto switch model	D-A9□ D-A9□V D-M9□ D-M9□V D-M9□W D-M9□WV D-M9□AL D-M9□AVL	D-A7□ D-A80	D-A7□H D-A80H D-F7□ D-J79 D-F7□W D-J79W D-F7BAL D-F79F D-F7NTL	D-A73C D-A80C	D-F7□V D-F7□WV D-F7BAVL	D-J79C	D-A79W	D-P4DWL
	U	U	U	U	U	U	U	U
12	20.5	19.5	20.5	26.5	23	26	22	—
16	23.5	22.5	23.5	29.5	26	29	25	—
20	25.5	24.5	25.5	31.5	28	31	27	—
25	28.5	27.5	28.5	34.5	31	34	30	—
32	32.5	31.5	32.5	38.5	35	38	34	—
40	36	35	36	42	38.5	41.5	37.5	44
50	42	41	42	48	44.5	47.5	43.5	50
63	48.5	47.5	48.5	54.5	51	54	50	56.5
80	58.5	57.5	58.5	64.5	61	64	60	66.5
100	68.5	67.5	68.5	74.5	71	74	70	76.5

Applicable Cylinder Series: CDBQ2 (End lock) (mm)

Auto switch model	D-A7□ D-A80	D-A7□H D-A80H/J79W D-F7□/F7BAL D-J79/F79F D-F7□W/F7NTL	D-A73C D-A80C	D-F7□V D-F7□WV D-F7BAVL	D-J79C	D-A79W	D-A9□V	D-M9□V D-M9□WV D-M9□AVL	D-P4DWL
	U	U	U	U	U	U	U	U	U
20	—	—	—	—	—	—	22.5	24.5	—
25	—	—	—	—	—	—	24.5	26.5	—
32	31.5	32.5	38.5	35	38	34	27	29	—
40	35	36	42	38.5	41.5	37.5	30.5	32.5	44
50	41	42	48	44.5	47.5	43.5	36.5	38.5	50
63	47.5	48.5	54.5	51	54	50	40	42	56.5
80	57.5	58.5	64.5	61	64	60	50	52	66.5
100	67.5	68.5	74.5	71	74	70	60	62	76.5

CUJ

CU

CQS

CQ2

RQ

CQM

MU

D-□

-X□

Individual
-X□

Technical
data

Compact Cylinder/*Series CQ2* With Auto Switch 4

1 Proper Auto Switch Mounting Position (Detection at stroke end) and Mounting Height

Applicable cylinder series: CDQ2, CDQ2W (Large bore size)

D-A9□
D-M9□
D-M9□W
D-M9□AL

D-A9□V
D-M9□V
D-M9□WV
D-M9□AVL

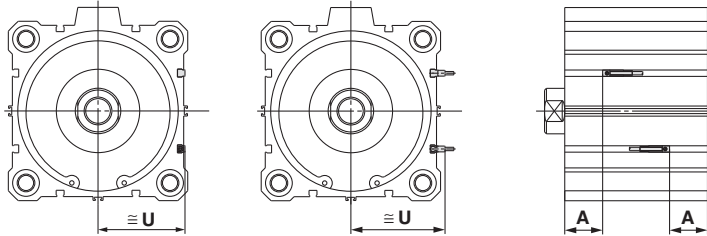

D-A7□
D-A80
D-A7□H
D-A80H
D-F7□
D-J79
D-F7□W
D-J79W
D-F79F

D-F7NTL
D-F7BAL
D-A73C
D-A80C
D-J79C
D-A79W
D-F7□WV
D-F7□V
D-F7BAVL



D-Z7□
D-Z80
D-Y59□
D-Y7P
D-Y7□W
D-Y7BAL

D-Y69□
D-Y7PV
D-Y7□WV

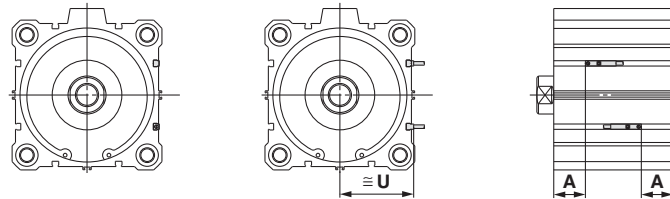

Proper Auto Switch Mounting Position

Auto switch model	Bore size						
	D-A9□ D-A9□V	D-M9□ D-M9□V D-M9□W D-M9□WV D-M9□AL D-M9□AVL	D-A73 D-A80	D-A727□H/A80H D-A73C/A80C D-F7□/F7□V D-F79F/F7□W D-F7□WV/J79 D-J79W/J79C D-F7BAL D-F7BAVL	D-A79W	D-F7NTL	D-Z7□/Z80 D-Y59□/Y69□ D-Y7P/Y7PV D-Y7□W/Y7□WV D-Y7BAL
Bore size	A	A	A	A	A	A	A
125	30	34	32.5	33	30	38	29
140	30	34	32.5	33	30	38	29
160	34	38	36.5	37	34	42	33
180	40.5	44.5	—	—	—	—	38.5
200	43.5	47.5	—	—	—	—	42

Note) Adjust the auto switch after confirming the operating conditions in the actual setting.

Auto Switch Mounting Height

Auto switch model	Bore size									
	D-A9□ D-M9□ D-M9□W D-M9□AL	D-M9□V D-M9□WV D-M9□AVL	D-A9□V D-Y69□ D-Y7PV D-Y7□WV	D-A7□ D-A80	D-A7□H D-A80H D-F7□/J79 D-F7□W D-J79W D-F7BAL D-F79F D-F7NTL	D-A73C D-A80C	D-F7□V D-F7□WV D-F7BAVL	D-J79C	D-A79W	
Bore size	U	U	U	U	U	U	U	U	U	
125	69.5	74	72	80	81	87	83.5	85.5	82.5	
140	77.5	82	80	88	89	95	91.5	93.5	90.5	
160	87.5	92	90	98	99	105	101.5	103.5	100.5	
180	99.5	104	102	—	—	—	—	—	—	
200	109.5	114	112	—	—	—	—	—	—	

2 Minimum Auto Switch Mounting Stroke

Applicable cylinder series: CDQ2, CDQ2W, CDQ2□□□-□S/□T (Single acting), CDQ2K, CDQ2KW (Non-rotating), CDQP2, CDQP2□□□-□S/□T (Axial piping), CDQ2 (Long stroke), CDQ2□S (Anti-lateral load), CDBQ2 (End lock), CDQ2□R/□V (Water resistant) (mm)

No. of auto switch mounted	D-M9□V D-F7□V D-J79C	D-A9□V D-A7□ D-A80 D-A73C D-A80C	D-A9□	D-M9□WV D-M9□AVL* D-F7□WV D-F7BAVL*	D-M9□ D-M9□W D-M9□AL* D-A7□H D-A80H D-F7□ D-J79	D-A79W	D-F7□W D-J79W D-F7BAL* D-F79F D-F7NTL	D-P4DWL
1 pc.	5	5	10	10	15	15	20	15
2 pcs.	5	10	10	15	15	20	20	15

* The applicable auto switches for CDQ2□R/□V (water resistant) are D-M9□A(V)L and D-F7BA(V)L.

Applicable cylinder series: CDQ2, CDQ2W (Large bore size) (mm)

No. of auto switch mounted	D-M9□ D-M9□V D-F7□/F7□V	D-J79/J79C D-Y59□/Y69□ D-Y7P/Y7PV	D-A9□ D-A9□V D-A7□/A80	D-A73C/A80C D-A7□H/Z7□ D-Z80/A80H	D-M9□W D-M9□WV D-M9□AL D-M9□AVL D-F7□W/F7□WV	D-J79W D-F7BAL/F7BAVL D-F7NTL/F79F D-F7□W/Y7□WV D-Y7BAL	D-A79W
1 pc.		5		5		10	15
2 pcs.		5		10		15	20

3 Operating Range

Applicable cylinder series: CDQ2, CDQ2W, CDQ2□□□-□S/□T (Single acting), CDQ2K, CDQ2KW (Non-rotating), CDQP2, CDQP2□□□-□S/□T (Axial piping), CDQ2 (Long stroke), CDQ2□S (Anti-lateral load), CDBQ2 (End lock), CDQ2, CDQ2W (Large bore size), CDQ2□R/□V (Water resistant) (mm)

Auto switch model	Bore size														
	12	16	20	25	32	40	50	63	80	100	125	140	160	180	200
D-A9□(V)	7.5	9.5	9 [10]	9 [10]	9.5 (9.5)	9.5 (9.5)	9.5 (8.5)	11.5 (11)	9 (10)	11.5 (10.5)	12	12.5	12	10.5	9.5
D-M9□(V) D-M9□W(V) D-M9□A(V)L	3.5	5	5 [5.5]	5 [5.5]	6 (5.5)	6 (5.5)	7 (6)	7.5 (6.5)	8 (7)	8.5 (7)	8.5	8.5	9	10	10
D-A7□(H)(C) D-A80□(H)(C)	10	12	12	12	12	11	10	12	12	13	13	13	13	—	—
D-A79W	13	13	13	13	13	14	14	16	15	17	17	17	17	—	—
D-Z7□ D-Z80	—	—	—	—	—	—	—	—	—	—	14	14	14	15	15.5
D-F7□(V) D-J79(C) D-F7□W(V) D-F7BA(V)L D-F7NTL D-F79F	5.5	6	5.5	5	6	6	6	6.5	6.5	7	9	9	8.5	—	—
D-Y59□ D-Y69□ D-Y7P(V) D-Y7□W(V) D-Y7BAL	—	—	—	—	—	—	—	—	—	—	11.5	11.5	11.5	12	12
D-P4DWL	—	—	—	—	—	5	5	5	5	5.5	—	—	—	—	—

* Since the operating range is provided as a guideline including hysteresis, it cannot be guaranteed (assuming approximately ±30% dispersion). It may vary substantially depending on an ambient environment.

* Except for a bore size over ø32 of D-A9□(V)/M9□(V)/M9□W(V)/M9□A(V)L types, the values above are measured when the conventional switch installation groove is attached without using the auto switch mounting bracket BQ2-012.

* The values in parentheses for a bore size over ø32 of D-A9□(V)/M9□(V)/M9□W(V)/M9□A(V)L types indicate the operating range of the CDQP2 and CDQP2□□□-□S/□T series when the auto switch mounting bracket BQ2-012 is used.

* The values in [] for ø20 and ø25 of D-A9□(V)/M9□(V)/M9□W(V)/M9□A(V)L Types are applicable for Series CDBQ2 (end lock).

* The applicable auto switches for CDQ2□R/□V (water resistant) are D-M9□A(V)L and F7BA(V)L.

CUJ

CU

CQS

CQ2

RQ

CQM

MU

D-□

-X□

Individual
-X□

Technical
data

Compact Cylinder/*Series CQ2* With Auto Switch 5

4 Auto Switch Mounting Bracket: Part No.

Applicable cylinder series: CDQ2, CDQ2W, CDQ2□□□-□S/□T (Single acting), CDQ2K, CDQ2KW (Non-rotating), CDQP2, CDQP2□□□-□S/□T (Axial piping), CDQ2 (Long stroke), CDQ2□S (Anti-lateral load), CDBQ2 (End lock), CDQ2□R/□V (Water resistant)

Auto switch mounting surface	Bore size (mm)		
	ø12, ø16, ø20, ø25	ø32, ø40, ø50	ø63, ø80, ø100
Auto switch model	Auto switch mounting surface	Auto switch mounting surface	Auto switch mounting surface
	Auto switch mounting rail only	Port side	Port, A, B, C
	① BQ-1 ② BQ2-012 Two kinds of auto switch bracket are used as a set. D-A9□ D-A9□V D-M9□ D-M9□V D-M9□W D-M9□WV D-M9□AL D-M9□AVL	Auto switch mounting brackets are not required. 	Auto switch mounting brackets are not required. ⁽³⁾

Note 1) When a compact auto switch is mounted on the three sides (A, B and C above) other than the port side of CDQ2□32 to 50, auto switch mounting brackets shown above are required. Order them separately from cylinders. (The above is also applicable when a compact auto switch is mounted using an auto switch mounting rail, but not using a compact auto switch installation groove for CDQ2□63 to 100.)

Order example
 CDQ2B32-100DM-M9BW.....1
 BQ-2.....2 pcs.
 BQ2-012.....2 pcs.

Note 2) When shipping cylinders, auto switch mounting brackets and auto switches are shipped together.

Note 3) Be sure to use BQ-2 or BQ2-012 when mounting ø63, ø80 or ø100 of the CDQP2 series.

Auto switch model	Bore size (mm)		
	ø12 to ø25	ø32	ø40 to ø100
D-A7□/A80 D-A73C/A80C D-A7□H/A80H D-A79W D-F7□/J79 D-F7□V D-J79C D-F7□W/J79W D-F7□WV D-F7BAL/F7BAVL D-F79F/F7NTL	BQ-1		BQ-2
D-P4DWL	—		BQP1-050

Note 4) When shipping cylinders, auto switch mounting brackets and auto switches are shipped together. However, when ø40 to ø100 of D-P4DWL type are mounted, the auto switch is assembled at the time of shipment.

[Mounting screw set made of stainless steel]

The following set of mounting screws made of stainless steel is available. Use it in accordance with the operating environment. (Please order BQ-2 separately, since auto switch spacers (for BQ-2) are not included.)

BBA2: For D-A7/A8/F7/J7 types

The above stainless steel screws are used when a cylinder is shipped with D-F7BAL, F7BAVL-type auto switches.

When only an auto switch is shipped independently, BBA2 is attached.

Note 5) Refer to page 1361 for the details of BBA2.

Note 6) When D-M9□A(V)L is mounted on a port side other than ø32, ø40 or ø50, order auto switch mounting brackets BQ2-012S, BQ-2 or the stainless steel screw set BBA2 separately.

Auto Switch Mounting Bracket Mass

Mounting bracket part No.	Applicable bore size	Mass (g)
BQ-1	ø12 to ø25	1.5
BQ-2	ø32 to ø100	1.5
BQ2-012	ø12 to ø25	5
BQP1-050	ø40 to ø100	16

Applicable cylinder series: CDQ2, CDQ2W (Large bore size)

Auto switch model	Bore size (mm)				
	ø125	ø140	ø160	ø180	ø200
D-A9□/A9□V D-M9□/M9□V D-M9□W/M9□WV D-M9□AL/M9□AVL	BMG2-012				
D-A7□/A80 D-A73C/A80C D-A7□H/A80H D-A79W D-F7□/J79 D-F7□V D-J79C D-F7□W/J79W D-F7□WV D-F7BAL/F7BAVL D-F79F/F7NTL	BQ-2		—		

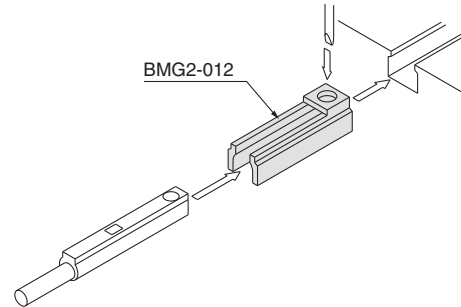

• The above figure shows how to mount D-A9□(V)/M9□(V)/M9□W(V)/M9□A(V)L types on CDQ2 or CDQ2W (large bore size).

Auto Switch Mounting Bracket Mass

Mounting bracket part no.	Applicable cylinder size	Mass (g)
BQ-2	ø125 to ø160	1.5
BMG2-012	ø125 to ø200	3

Besides the models listed in How to Order, the following auto switches are applicable.

Refer to pages 1263 to 1371 for details.

Applicable cylinder series: CDQ2, CDQ2W, CDQ2□□□-□S/-□T (Single acting), CDQ2K, CDQ2KW (Non-rotating), CDQP2, CDQP2□□□-□S/-□T (Axial piping), CDQ2 (Long stroke), CDQ2□S (Anti-lateral load), CDBQ2 (End lock), CDQ2, CDQ2W (Large bore size), CDQ2□R/□V (Water resistant)

Auto switch type	Part no.	Electrical entry	Features	Applicable bore size
Reed	D-A73	Grommet (Perpendicular)	—	ø12 to ø160
	D-A80		Without indicator light	
	D-A73H, A76H		—	
	D-A80H	Grommet (In-line)	Without indicator light	ø125 to ø200
	D-Z73, Z76		—	
	D-Z80		Without indicator light	
Solid state	D-F7NV, F7PV, F7BV	Grommet (Perpendicular)	—	ø12 to ø160
	D-F7NWV, F7BWW		Diagnostic indication (2-color indication)	
	D-F7BAVL		Water resistant (2-color indication)	
	D-F79, F7P, J79	Grommet (In-line)	—	
	D-F79W, F7PW, J79W		Diagnostic indication (2-color indication)	
	D-F7BAL**		Water resistant (2-color indication)	
	D-F7NTL	With timer	ø125 to ø200	
	D-Y69A, Y69B, Y7PV	Grommet (Perpendicular)		—
	D-Y7NWV, Y7PWW, Y7BWW			Diagnostic indication (2-color indication)
	D-Y59A, Y69B, Y7P			Grommet (In-line)
	D-Y7NW, Y7PW, Y7BW	Diagnostic indication (2-color indication)		
	D-Y7BAL	Water resistant (2-color indication)		
D-P5DWL	Magnetic field resistant (2-color indication)	ø40 to ø100		

* For solid state auto switches, auto switches with a pre-wired connector are also available. Refer to pages 1328 and 1329 for details.

** Normally closed (NC = b contact) solid state auto switches (D-F9G/F9H/Y7G/Y7H types) are also available. Refer to pages 1290 and 1292 for details.

* The applicable auto switch for CDQ2□R/□V (water resistant) is D-F7BA(V)L.

CUJ

CU

CQS

CQ2

RQ

CQM

MU

D-□

-X□

Individual

-X□

Technical data