



Standard cylinder—SI Series

In accordance with ISO15552 standard

Compendium of SI Series

ISO15552 Standard cylinder
Bore size: 32、40、50、63、80
100、125、160、200

Adjustable air buffer
With adjustable air buffer on the front and back cover

Without tie rod
The \ast -shaped aluminum pipe without tie rod has good corrosion resistance;

Convenient and fast fix sensor switch
Sensor switch can be directly fixed onto the cylinder, which is convenient and fast.
the counterpart sensor switch type is:
CS1-B、DS1-B、CS1-F、DS1-F、CS1-U、DS1-U

Four kinds of cylinder joints
I Knuckle Y Knuckle Floating Joint Universal Joint

Multi-mounting accessories
LB FA FB
CA CB CR
FTC TCM1 TCM2
TC

Multi-type cylinder
SI: Double acting type SID: Double rod type SIJ: Adjustable stroke type

Criteria for selection: Cylinder thrust

Unit: Newton(N)

Bore size	Rod size	Acting type	Pressure area(mm ²)	Operating pressure(MPa)								
				0.1	0.2	0.3	0.4	0.5	0.6	0.7	0.8	0.9
32	12	Double acting Push side	804	80.4	160.8	241.2	321.6	402.0	482.4	562.8	643.2	723.6
		Pull side	690	69.0	138.0	207.0	276.0	345.0	414.0	483.0	552.0	621.0
40	16	Double acting Push side	1256	125.6	251.2	376.8	502.4	628.0	753.6	879.2	1002.4	1130.4
		Pull side	1055	105.5	211.0	316.5	422.0	527.5	633.0	738.5	844.0	949.5
50	20	Double acting Push side	1963	196.3	392.6	588.9	785.2	981.5	1177.8	1374.1	1570.4	1766.7
		Pull side	1649	164.9	329.8	494.7	659.6	824.5	989.4	1154.3	1399.2	1484.1
63	20	Double acting Push side	3117	311.7	623.4	935.1	1246.8	1558.5	1870.2	2181.9	2493.6	2805.3
		Pull side	2803	280.3	560.6	840.9	1121.2	1401.5	1681.8	1962.1	2242.4	2522.7
80	25	Double acting Push side	5026	502.6	1005.2	1507.8	2010.4	2513.0	3015.6	3518.2	4020.8	4523.4
		Pull side	4536	453.6	907.2	1360.8	1814.4	2268.0	2721.6	3175.2	3628.8	4082.4
100	25	Double acting Push side	7853	785.3	1570.6	2355.9	3141.2	3926.5	4711.8	4288.2	6282.4	7067.7
		Pull side	7362	736.2	1472.4	2208.6	2948.6	3681.0	4417.2	5153.4	5889.6	6625.8
125	32	Double acting Push side	12272	1227.2	2454.4	3681.6	4908.8	6136.0	7363.2	8590.4	9817.6	11044.8
		Pull side	11468	1146.8	2293.6	3440.4	4587.2	5734.0	6880.8	8027.6	9174.4	10321.2
160	40	Double acting Push side	20106	2010.6	4021.2	6031.8	8042.4	10053.0	12063.6	14074.2	16084.8	18095.4
		Pull side	18849	1884.9	3769.8	5654.7	7539.6	9424.5	11309.4	13194.3	15079.2	16964.1
200	40	Double acting Push side	31416	3141.6	6283.2	9424.8	12566.4	15708.0	18849.6	21991.2	25132.8	28274.4
		Pull side	30157	3015.7	6031.4	9047.1	12062.8	15078.5	18094.2	21109.9	24125.6	27141.3

Installation and application



- When load changes in the work, the cylinder with abundant output capacity shall be selected.
- Relative cylinder with high temperature resistance or corrosion resistance shall be chosen under the condition of high temperature or corrosion.
- Necessary protection measure shall be taken in the environment with higher humidity, much dust or water drops, oil dust and welding dregs.
- Dirty substances in the pipe must be eliminated before cylinder is connected with pipeline to prevent the entrance of particles into the cylinder.
- The medium used by cylinder shall be filtered to 40 μ m or below.
- Anti-freezing measure shall be adopted under low temperature environment to prevent moisture freezing.
- The cylinder shall be carried out test run without load before application. Prior to run, buffer shall be turned to the minimum and gradually released to avoid the damage on cylinder caused by excessive impact.
- The cylinder shall avoid the influence of side load in operation to maintain the normal work of cylinder and extend the service life.
- If the cylinder is dismantled and stored for a long time, please conduct anti-rust treatment to the surface. Anti-dust caps shall be added in air inlet and outlet ports.



ISO15552 Standard cylinder

SI Series



Specification

Bore size(mm)	32	40	50	63	80	100	125	160	200
Acting type	Double acting								
Fluid	Air(to be filtered by 40 μm filter element)								
Mounting type	SI	Basic FA FB CA CB CR LB TC FTC TCM1 TCM2							
	SID、SIJ	Basic FA LB TC FTC TCM1 TCM2							
Operating pressure	0.15~1.0MPa(22~145psi)(1.5~10.0bar)								
Proof pressure	1.5MPa(215psi)(15bar)								
Temperature °C	-20~70								
Speed range mm/s	30~800						30~500		
Stroke tolerance	0~250 ^{+1.0} ₀ 251~1000 ^{+1.5} ₀ 1001~1500 ^{+2.0} ₀								
Cushion type	Variable cushion								
Adjustable cushion stroke	27		30		36		40		50
Port size [Note1]	1/8"	1/4"	3/8"		1/2"		3/4"		

[Note1] PT thread, G thread and NPT thread are available.
Add) Refer to P349 for detail of sensor switch.

Stroke

Bore size (mm)	Standard stroke (mm)																Max.std stroke	Max. stroke					
32	25	50	75	80	100	125	150	160	175	200	250	300	350	400	450	500	1000	1800					
40	25	50	75	80	100	125	150	160	175	200	250	300	350	400	450	500	600	700	800	1200	1800		
50	25	50	75	80	100	125	150	160	175	200	250	300	350	400	450	500	600	700	800	900	1000	1200	1800
63	25	50	75	80	100	125	150	160	175	200	250	300	350	400	450	500	600	700	800	900	1000	1500	1800
80	25	50	75	80	100	125	150	160	175	200	250	300	350	400	450	500	600	700	800	900	1000	1500	1800
100	25	50	75	80	100	125	150	160	175	200	250	300	350	400	450	500	600	700	800	900	1000	1500	1800
125	25	50	75	80	100	125	150	160	175	200	250	300	350	400	450	500	600	700	800	900	1000	1500	1800
160	25	50	75	80	100	125	150	160	175	200	250	300	350	400	450	500	600	700	800	900	1000	1500	2000
200	25	50	75	80	100	125	150	160	175	200	250	300	350	400	450	500	600	700	800	900	1000	1500	2000

[Note] Consult us for non-standard stroke.

Symbol

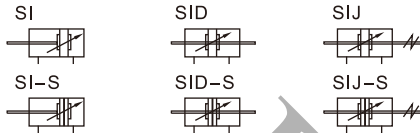

Product feature

- ISO15552 (original ISO6431) standard cylinder;
- The piston seal is composed of two Y-shape one-way seal structure, which has compensation function, long service life and low start-up pressure;
- The *-shaped aluminum pipe without tie rod has good corrosion resistance;
- The buffer adjustment of cylinder is smooth and steady;
- Cylinders and accessories for installation with several specifications are optional.

Ordering code

SI 160 x **50** **S**
SID160 x **50** **S**
SIJ 160 x **50-20** **S**

① ② ③ ④ ⑤ ⑥ ⑦ ⑧ ⑨

① Model	② Bore size	③ Rod Material	④ Stroke	⑤ Adjustable stroke	⑥ Magnet	⑦ Mounting type[Note1]	⑧ Seals Material	⑨ Thread type
SI: Double acting type	32 40 50 63 80	Blank: Medium carbon steel A: SUS420J2 B: SUS304	Refer to stroke table for details	No this code	Blank: Without magnet S: With magnet	Blank LB FA FB CA CB CR FTC TC	Blank: TPU H: Viton N: NBR	Blank: PT G: G T: NPT
SID: Double rod type	100 125 160 200					Blank LB FA		
SIJ: Adjustable stroke type				10 20 30 40 50 75 100		FTC TC		

[Note1] CR is used with CB; FTC、TC are used with TCM1、TCM2.

ISO15552 Standard cylinder

SI Series

Inner structure and material of major parts

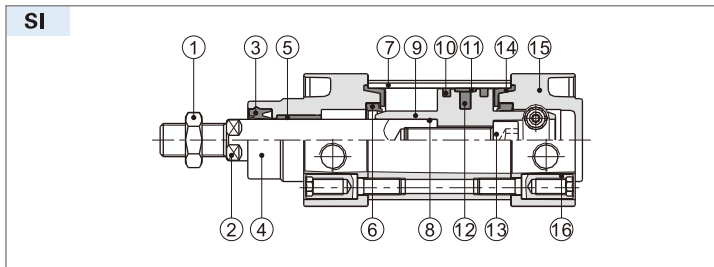

NO.	Item	Material
1	Rod nut	Carbon steel\Stainless steel
2	Piston rod	Carbon steel with 20 μ m chrome plated or Stainless steel
3	Front cover packing	TPU
4	Front cover	Aluminum alloy
5	Bushing	Wear resistant material
6	Cushing O-ring	TPU
7	Barrel	Aluminum alloy
8	O-ring	NBR
9	Piston	Aluminum alloy
10	Piston Seal	TPU
11	Wear ring	Wear resistant material
12	Magnet	Plastic(Φ 100 and below)\Rubber(Others)
13	Bolt	Carbon steel
14	Buffer gasket	TPU
15	Back cover	Aluminum alloy
16	Screw	Carbon steel\Stainless steel

Dimensions

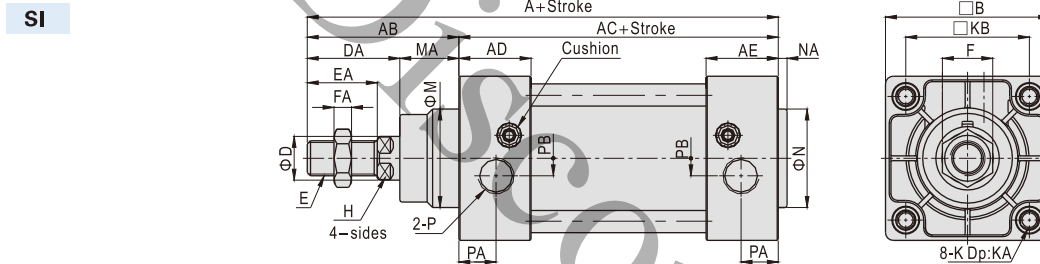

Bore size\Item	A	AB	AC	AD	AE	B	D	DA	E	EA	F	FA	M	MA	H	K(Without TC)	K(WithTC)	KA(Without TC)	KA(WithTC)	KB	N	NA	P	PA	PB
32	142	48	94	27.5	27.5	47	12	29	M10×1.25	22	17	6	30	19	10	M6	M5	16	14	32.5	30	3	1/8"	13	5.5
40	159	54	105	32	32	53	16	33	M12×1.25	24	17	7	35	21	13	M6	M5	16	16	38	35	3.5	1/4"	17	6
50	175	69	106	31	31	65	20	42	M16×1.5	32	23	8	40	27	17	M8	M6	16	16	46.5	40	3.5	1/4"	15.5	7.5
63	190	69	121	33	33	75	20	42	M16×1.5	32	23	8	45	27	17	M8	M6	16	16	56.5	45	4	3/8"	16.5	7.5
80	214	86	128	33	33	95	25	53	M20×1.5	40	26	10	45	33	22	M10	M8	17	16	72	45	4	3/8"	16.5	9
100	229	91	138	37	37	115	25	55	M20×1.5	40	26	10	55	36	22	M10	M8	17	16	89	55	4	1/2"	18.5	9.5
125	279	119	160	46	46	140	32	74	M27×2.0	54	41	13.5	60	45	27	M12	M12	20	20	110	60	4	1/2"	23	14
160	332	152	180	50	50	180	40	94	M36×2.0	72	55	18	65	58	36	M16	M16	24	24	140	65	4	3/4"	25	15
200	347	167	180	50	50	220	40	100	M36×2.0	72	55	18	75	67	36	M16	M16	24	24	175	75	5	3/4"	25	15

Remark: The dimensions of magnet type cylinder are the same as non-magnet type cylinder.

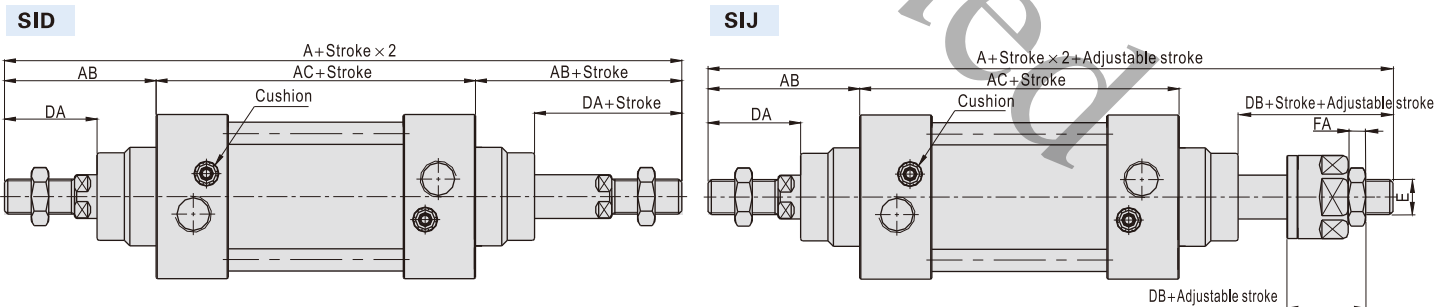

Bore size\Item	A		AB	AC	DA	DB	E	FA
	SID	SIJ						
32	190	188	48	94	29	27	M10X1.25	6
40	213	208	54	105	33	28	M12X1.25	7
50	244	231	69	106	42	29	M16X1.5	8
63	259	246	69	121	42	29	M16X1.5	8
80	300	282.5	86	128	53	35.5	M20X1.5	10
100	320	300.5	91	138	55	35.5	M20X1.5	10
125	398	366.5	119	160	74	42.5	M27X2.0	13.5
160	484	458	152	180	94	68	M36X2.0	18
200	514	482	167	180	100	68	M36X2.0	18

Remark:
 1. The dimensions of magnet type cylinder are the same as non-magnet type cylinder.
 2. The unmarked dimension is the same as SI standard type.



List for ordering code of accessories

Accessories Cylinder model	Mounting accessories								
	LB	FA/FB	CA	CB	CR	TC	FTC	TCM1	TCM2
32	F-SI32LB	F-SI32FA	F-SI32CA	F-SI32CB	F-SI32CR	F-SI32TC	F-SI32FTC	F-SI32TCM1	F-SI32TCM2
40	F-SI40LB	F-SI40FA	F-SI40CA	F-SI40CB	F-SI40CR	F-SI40TC	F-SI40FTC	F-SI40TCM1	F-SI40TCM2
50	F-SI50LB	F-SI50FA	F-SI50CA	F-SI50CB	F-SI50CR	F-SI50TC	F-SI50FTC	F-SI50TCM1	F-SI50TCM2
63	F-SI63LB	F-SI63FA	F-SI63CA	F-SI63CB	F-SI63CR	F-SI63TC	F-SI63FTC	F-SI63TCM1	F-SI63TCM2
80	F-SI80LB	F-SI80FA	F-SI80CA	F-SI80CB	F-SI80CR	F-SI80TC	F-SI80FTC	F-SI63TCM1	F-SI63TCM2
100	F-SI100LB	F-SI100FA	F-SI100CA	F-SI100CB	F-SI100CR	F-SI100TC	F-SI100FTC	F-SI125TCM1	F-SI125TCM2
125	F-SI125LB	F-SI125FA	F-SI125CA	F-SI125CB	F-SI125CR	F-SI125TC	F-SI125FTC	F-SI125TCM1	F-SI125TCM2
160	F-SI160LB	F-SI160FA	F-SI160CA	F-SI160CB	F-SI160CR	F-SI160TC	F-SI160FTC	F-SI160TCM1	F-SI160TCM2
200	F-SI200LB	F-SI200FA	F-SI200CA	F-SI200CB	F-SI200CR	F-SI200TC	F-SI200FTC	F-SI200TCM1	F-SI160TCM2

Accessories Cylinder model	Knuckle				Sensor switch		CS1-F	DS1-F	CS1-U	DS1-U
	I	Y	F	U	CS1-B□	DS1-B□				
32	F-M10X125I	F-M10X125Y	F-M10X125F	F-M10X125U	CS1-B1	DS1-B1	CS1-F	DS1-F	CS1-U	DS1-U
40	F-M12X125I	F-M12X125Y	F-M12X125F	F-M12X125U	CS1-B1	DS1-B1				
50	F-M16X150I	F-M16X150Y	F-M16X150F	F-M16X150U	CS1-B2	DS1-B2				
63	F-M16X150I	F-M16X150Y	F-M16X150F	F-M16X150U	CS1-B2	DS1-B2				
80	F-M20X150I	F-M20X150Y	F-M20X150F	F-M20X150U	CS1-B3	DS1-B3				
100	F-M20X150I	F-M20X150Y	F-M20X150F	F-M20X150U	CS1-B4	DS1-B4				
125	F-M27X200I	F-M27X200Y	-	F-M27X200U	CS1-B5	DS1-B5				
160	F-M36X200I	F-M36X200Y	-	F-M36X200U	CS1-B6	DS1-B6				
200	F-M36X200I	F-M36X200Y	-	F-M36X200U	CS1-B7	DS1-B7				

Accessory selection

Accessories Cylinder model	Mounting accessories									Knuckle [Note1]				Sensor switch						
	LB	FA	FB	CA	CB	CR	TC	FTC	TCM1	TCM2	I	Y	U	F	CS1-B	DS1-B	CS1-F	DS1-F	CS1-U	DS1-U
SI	Standard	●	●	●	●	●	●	●	●	●	●	●	●	●	×	×	×	×	×	×
	With magnet	●	●	●	●	●	●	●	●	●	●	●	●	●	●	●	●	●	●	●
SID	Standard	●	●	×	×	×	×	●	●	●	●	●	●	●	×	×	×	×	×	×
	With magnet	●	●	×	×	×	×	●	●	●	●	●	●	●	●	●	●	●	●	●
SIJ	Standard	●	●	×	×	×	×	●	●	●	●	●	●	●	×	×	×	×	×	×
	With magnet	●	●	×	×	×	×	●	●	●	●	●	●	●	●	●	●	●	●	●

[Note1] Please refer to P338-341 for knuckle detail.

Material of accessories

Accessories Bore size	Mounting accessories									Knuckle				
	LB	FA	FB	CA	CB	CR	TC	FTC	TCM1	TCM2	I	Y	F	U
32~100	○	●	●	◇	◇	◇	◇	■	■	●	□	□	□	□
125~200	□	□	□	□	□	□	□	□	□	●	□	□	□	□

●—Aluminum alloy, ■—Cast steel, ○—Low carbon steel, ◇—Nodular cast iron, □—Carbon steel.

Dimensions

LB

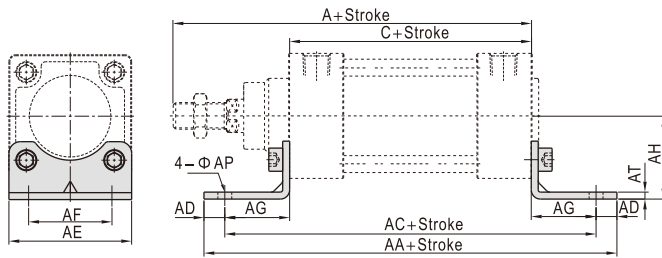

Bore size/Item	A	C	AA	AC	AD	AE	AF	AG	AH	AP	AT
32	142	94	158	142	8	47	32	24	32	7	3
40	159	105	179	161	9	53	36	28	36	9	3
50	175	106	190	170	10	65	45	32	45	9	3
63	190	121	209	185	12	75	50	32	50	9	3
80	214	128	248	210	19	95	63	41	63	12.5	4
100	229	138	266	220	19	115	75	41	71	14.5	4
125	279	160	290	250	20	140	90	45	90	16.5	8
160	332	180	340	300	20	180	115	60	115	18.5	8
200	347	180	380	320	30	220	135	70	135	24	9

CA

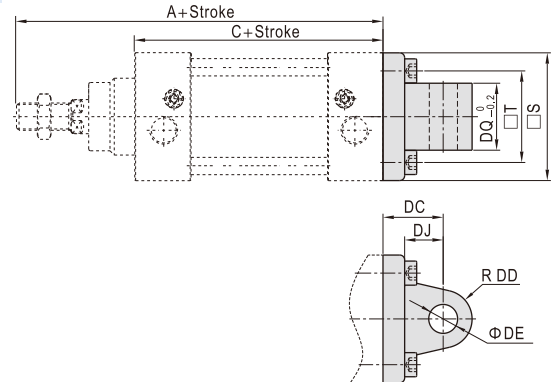

Bore size/Item	A	C	S	T	DC	DD	DE	DJ	DQ
32	142	94	47	32.5	22	9	10	13	25.8
40	159	105	52	38	25	10.5	12	16	27.8
50	175	106	64	46.5	27	11	12	17	31.7
63	190	121	74	56.5	32	13.5	16	22	39.7
80	214	128	94	72	36	14.5	16	22	49.7
100	229	138	113	89	41	17	20	27	59.7
125	279	160	139	110	50	22	25	33	69.7
160	332	180	180	140	55	30	30	35.5	89.7
200	347	180	220	175	60	30	30	37	89.7

FA/FB

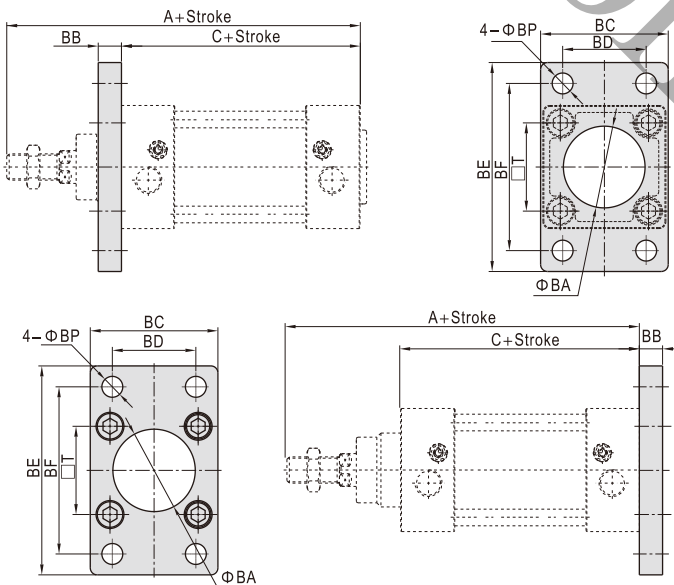

Bore size/Item	A	C	BA	BB	BC	BD	BE	BF	BP	T
32	142	94	30.5	10	47	32	80	64	7	32.5
40	159	105	35.5	10	53	36	90	72	9	38
50	175	106	40.5	12	65	45	108	90	9	46.5
63	190	121	45.5	12	75	50	118	100	9	56.5
80	214	128	45.5	16	95	63	150	126	12.5	72
100	229	138	55.5	16	115	75	176	150	14.5	89
125	279	160	60.5	20	139	90	218	180	16.5	110
160	332	180	65.5	20	180	115	280	230	18.5	140
200	347	180	75.5	25	220	135	320	270	24	175

CB

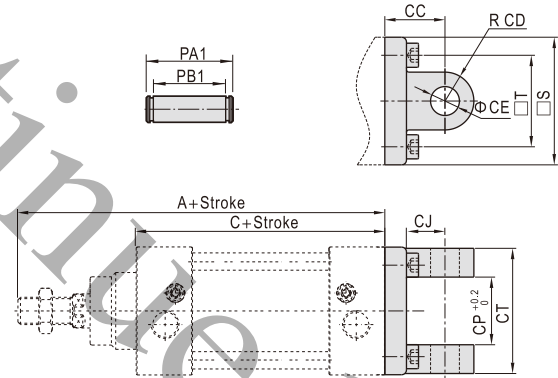

Bore size/Item	A	C	CC	CD	CE	CJ	CP	CT	PA1	PB1	S	T
32	142	94	22	9	10	13	26	45	51	45.5	47	32.5
40	159	105	25	10.5	12	16	28	52	59	52.5	52	38
50	175	106	27	11	12	17	32	60	67	60.5	64	46.5
63	190	121	32	13	16	22	40	70	77	70.5	74	56.5
80	214	128	36	14	16	22	50	90	97	90.5	94	72
100	229	138	41	17.5	20	27	60	110	119	110.5	113	89
125	279	160	50	21.5	25	33	70	130	139	130.5	139	110
160	332	180	55	30	30	35.5	90	170	181	170.5	180	140
200	347	180	60	30	30	36	90	170	181	170.5	220	175

ISO15552 Standard cylinder

SI Series—Accessories

TC

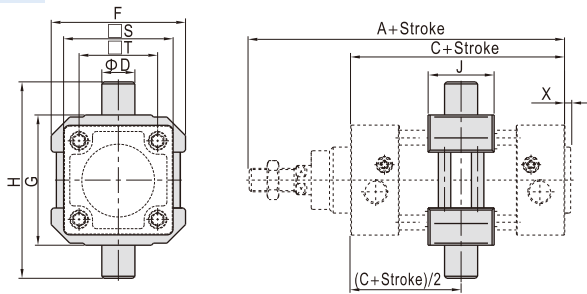

Bore size/Item	A	C	D	F	G	H	J	S	X	T
32	142	94	12	52	50	74	22	47	3	32.5
40	159	105	16	65	63	95	28	53	3.5	38
50	175	106	16	75	75	107	28	65	3.5	46.5
63	190	121	20	90	90	130	30	75	4	56.5
80	214	128	20	112	110	150	32	95	4	72
100	229	138	25	135	132	182	38	115	4	89
125	279	160	25	170	160	210	40	140	4	110
160	332	180	32	210	200	264	50	180	4	140
200	347	180	32	255	250	314	50	220	5	175

[Note] The TC accessory has been installed on the barrel of cylinder before it worked off, and the position of the accessories can not be adjusted arbitrarily. If consumer orders the TC solely, he will not install it on the barrel of standard cylinder directly.

FTC

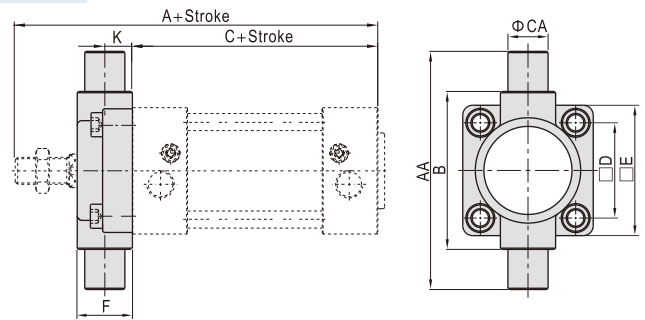

Bore size/Item	A	C	AA	B	CA	D	E	F	K
32	142	94	74	50	12	32.5	46	19	10
40	159	105	95	63	16	38	52	21	10
50	175	106	107	75	16	46.5	64	26	12
63	190	121	130	90	20	56.5	74	28	12
80	214	128	150	110	20	72	94	31	16
100	229	138	182	132	25	89	114	35	16
125	279	160	210	160	25	110	139	43	20
160	332	180	264	200	32	140	179	56	20
200	347	180	314	250	32	175	218	64	20

TCM1

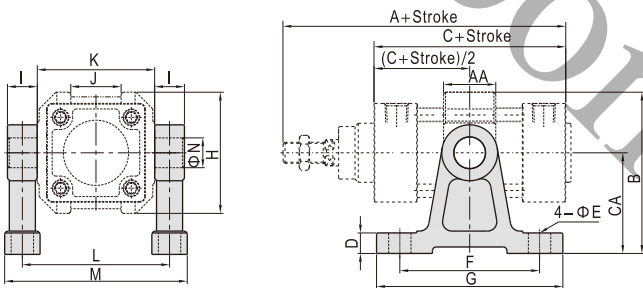

Bore size/Item	A	C	AA	B	CA	D	E	F	G	H	I	J	K	L	M	N
32	142	94	22	66	40	11	9	60	80	52	12	20	50	62	77	12
40	159	105	28	86.5	54	11	12	75	100	65	16	27	63	79	98	16
50	175	106	28	91.5	54	11	12	75	100	75	16	31	75	91	110	16
63	190	121	30	115	70	11	12	85	110	90	20	42	90	110	133	20
80	214	128	32	126	70	11	12	85	110	112	20	54	110	130	153	20
100	229	138	38	157.5	90	19	18	115	155	135	25	68	132	157	185	25
125	279	160	40	175	90	19	18	115	155	170	25	80	160	185	213	25
160	332	180	50	215	110	24	22	140	190	210	32	100	200	232	267	32
200	347	180	50	262.5	135	27	22	150	200	255	32	125	250	282	317	32

[Note] The installation position of the accessories can not be adjusted arbitrarily. When TCM1 be used with FTC, please refer to page 22.

TCM2

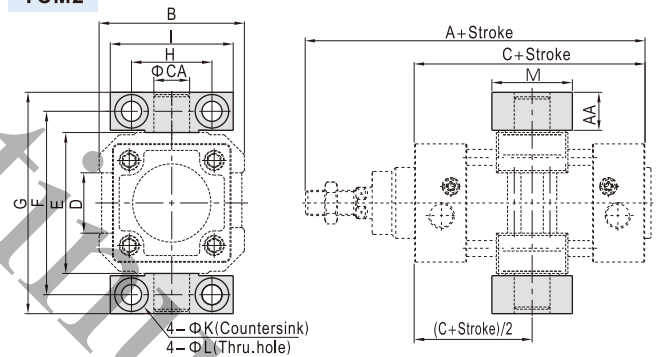

Bore size/Item	A	AA	B	C	CA	D	E	F	G	H	I	K	L	M
32	142	14	52	94	12	20	50	66	80	32	46	11	7	30
40	159	17	65	105	16	27	63	82	99	36	55	15	9	36
50	175	17	75	106	16	31	75	94	111	36	55	15	9	36
63	190	20.5	90	121	20	42	90	113.5	134	42	65	18	11	40
80	214	20.5	112	128	20	54	110	133.5	154	42	65	18	11	40
100	229	24.5	135	138	25	68	132	159.5	184	50	75	20	14	50
125	279	24.5	170	160	25	80	160	187.5	212	50	75	20	14	50
160	332	30	210	180	32	100	200	234	264	60	92	26	18	60
200	347	30	255	180	32	125	250	284	314	60	92	26	18	60

[Note] The installation position of the accessories can not be adjusted arbitrarily. When TCM2 be used with FTC, please refer to page 22.

CR

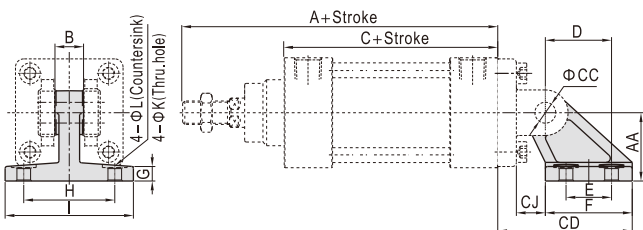

Bore size/Item	A	AA	B	C	CC	CD	CJ	D	E	F	G	H	I	K	L
32	142	32	26	94	10	50	10	21	18	31	8	38	51	6.6	-
40	159	36	28	105	12	56	12	24	22	35	10	41	54	6.6	-
50	175	45	32	106	12	68	13	33	30	45	12	50	65	9	-
63	190	50	40	121	16	77	17	37	35	50	12	52	67	9	-
80	214	63	50	128	16	93	19	47	40	60	14	66	86	11	18
100	229	71	60	138	20	106	22	55	50	70	15	76	96	11	18
125	279	90	70	160	25	135	26	70	60	90	20	94	124	14	20
160	332	115	90	180	30	171	25	97	88	126	25	118	156	14	20
200	347	135	90	180	30	185	31	105	90	130	30	122	162	18	26

[Note] CR can't be used alone, it must be used with CB.