



Tool EADT-S-M2

1. Applicable documents

 All available documents for this product → www.festo.com/pk

→ Assembly instructions of the line 

2. Safety

- Switch off power supply before mounting work.
- Observe applicable documents.

3. Intended use

Attachment of the screw-type lock to the plug connector.

4. Scope of delivery

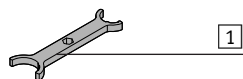

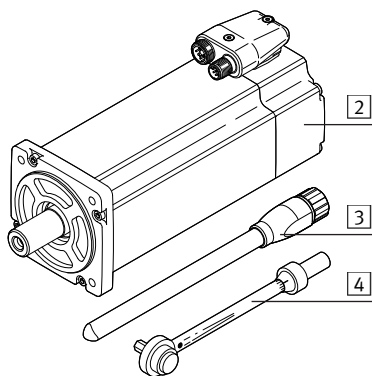

 Tool

5. Not in scope of delivery





 Servo motor
EMME-AS

 Line
with socket
M12/M16

 Torque spanner

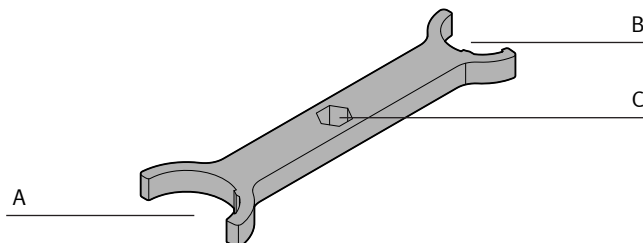
6. Function



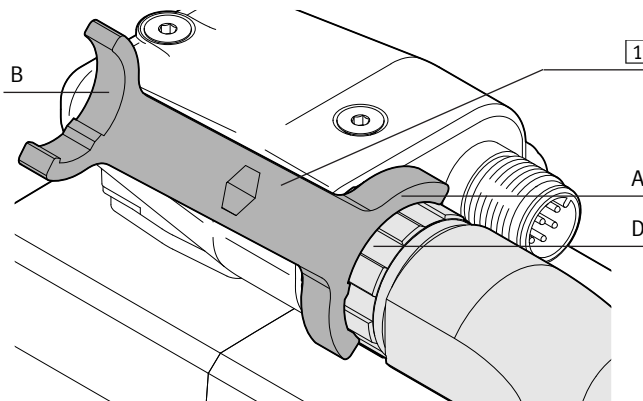

- Fork opening (A) for screw-type locks of sockets M16.
- Fork opening (B) for screw-type locks of sockets M12.
- Tool holder (C) for torque spanner .

7. Usage

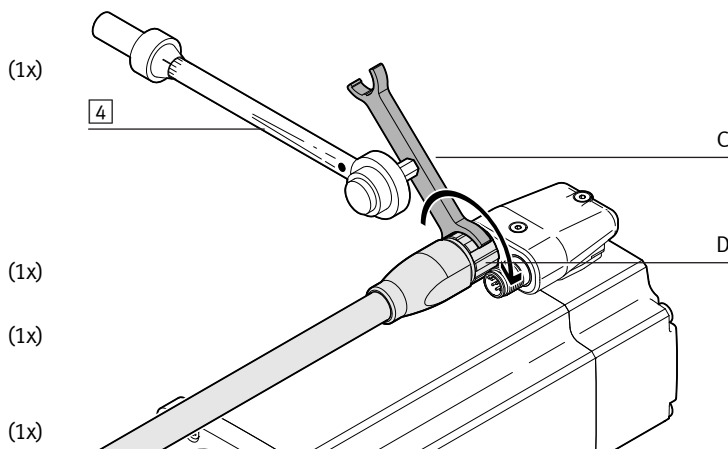

- Apply tool  with the correct fork opening (A)/(B) to the screw-type lock (D).



- Place torque spanner  in the tool holder (C).
- Tighten the screw-type lock (D). Observe the tightening torque (→ Further applicable documents).

7a. For lines with socket M16

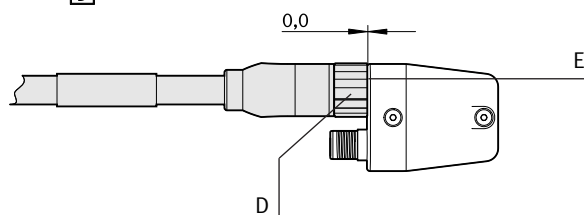

→ Screw-type lock (D) lies flush with the plug connector flange (E).