

# EAHF-E24-...-P-D

## Profile mounting

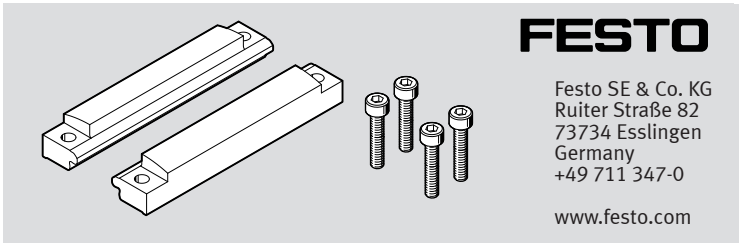

### Assembly instructions

8203093  
2023-12  
[8203095]



Translation of the original instructions

© 2024 all rights reserved to Festo SE & Co. KG

## 1 Applicable documents

All available documents for the product → [www.festo.com/sp](http://www.festo.com/sp).

Document	Product	Content
Operating instruction	Axis ELGD	-

Tab. 1: Applicable documents

## 2 Safety

### 2.1 Safety instructions

– Only mount the product on components that are in a condition to be safely operated.

### 2.2 Intended use

The profile mounting fastens an axis ELGD to the slide of an axis ELGD of the next larger size by the basic profile.

### 2.3 Training of qualified personnel

Work on the product may only be carried out by qualified personnel who can evaluate the work and detect dangers. Personnel must have the relevant mechanical training.

## 3 Additional information

- Contact the regional Festo contact if you have technical problems → [www.festo.com](http://www.festo.com).
- Accessories → [www.festo.com/catalogue](http://www.festo.com/catalogue).

## 4 Product Range Overview

### 4.1 Scope of delivery

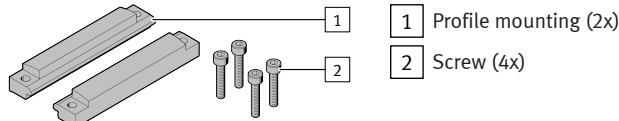

Fig. 1: Scope of delivery

### 4.2 Not in scope of delivery

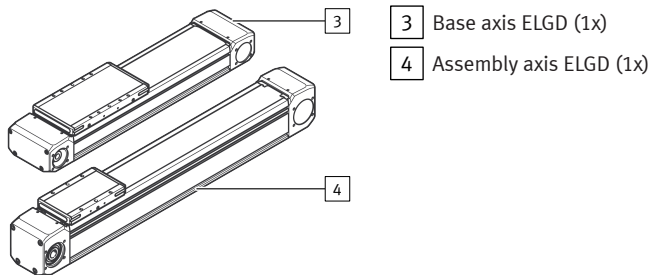

Fig. 2: Not included in the scope of delivery

## 5 Assembly

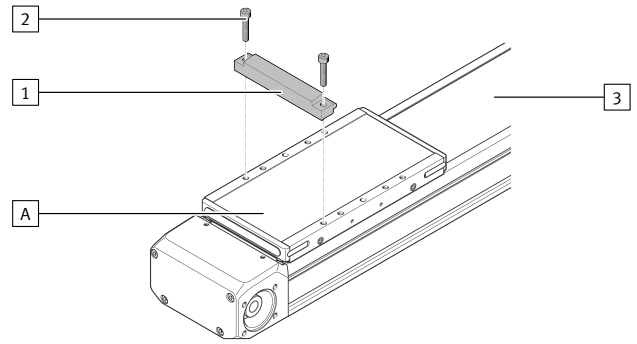

Fig. 3: Fastening first profile mounting

- Loosely attach the profile mounting [1] with the screws [2] to the slide [A] of the base axis [3].

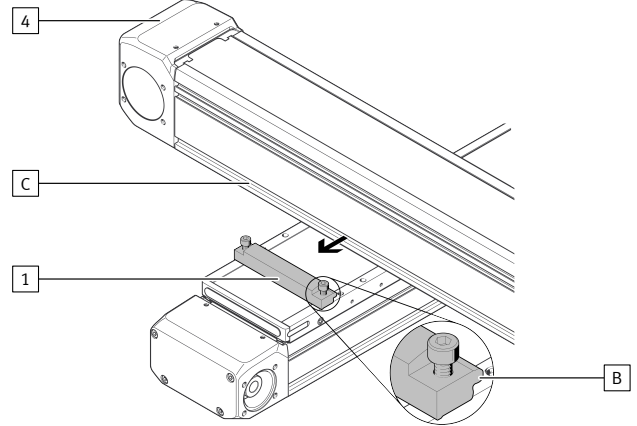

Fig. 4: Positioning assembly axis

- Position the assembly axis [4] on the profile mounting [1].  
↳ The lug [B] lies in the slot [C] of the assembly axis [4].

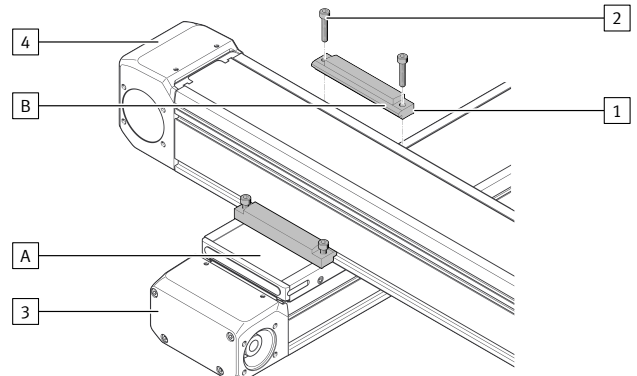

Fig. 5: Fastening second profile mounting

- Loosely attach the profile mounting [1] with the screws [2] to the slide [A] of the base axis [3].  
↳ The lug [B] lies in the slot of the assembly axis [4].

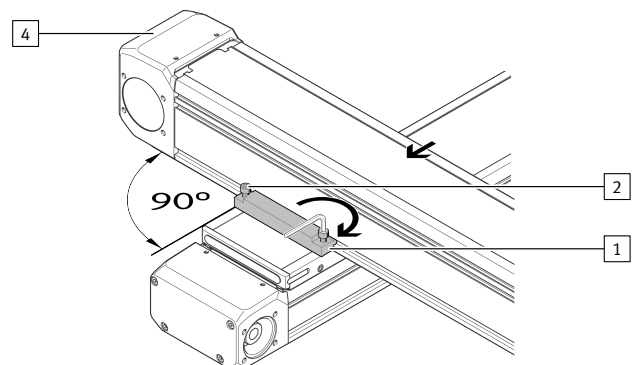

Fig. 6: Mounting assembly axis

1. Press the assembly axis [4] against the profile mounting [1].  
↳ The assembly axis [4] is aligned at the right angle.
2. Press the profile mountings [1] against the assembly axis [4].  
↳ The profile mountings [1] are flush with the assembly axis [4].
3. Tighten the four screws [2]. Observe tightening torque.

EAHF-E24-...-P-...	-D4	-D5	-D6
Screw	M6 x 25	M5 x 25	M5 x 25
	[Nm]	7.6 ± 20%	5.0 ± 20%