

Mechanically Jointed Rodless Cylinder Slide Bearing Guide Type

MY1M Series

ø16, ø20, ø25, ø32, ø40, ø50, ø63

How to Order

Slide bearing guide type **MY1M** **20** **G** - **300** - **M9BW** -

Slide bearing guide type • ① ② ③ ④ ⑤ ⑥ ⑦ ⑧

① Bore size

16	16 mm
20	20 mm
25	25 mm
32	32 mm
40	40 mm
50	50 mm
63	63 mm

② Port thread type

Symbol	Type	Bore size
Nil	M thread	ø16, ø20
	Rc	ø25, ø32,
TN	NPT	ø40, ø50,
TF	G	ø63

③ Piping

Nil	Standard type
G	Centralized piping type

④ Cylinder stroke [mm]

Bore size	Standard stroke* ¹	Long stroke	Maximum manufacturable stroke
16	100, 200, 300, 400, 500, 600, 700, 800, 900, 1000, 1200, 1400, 1600, 1800, 2000	Strokes of 2001 to 3000 mm (1 mm increments) exceeding the standard stroke	3000
20, 25, 32, 40, 50, 63	* ¹ The stroke can be manufactured in 1 mm increments from 1 mm stroke.	Strokes of 2001 to 5000 mm (1 mm increments) exceeding the standard stroke	5000

Ordering example

* Long stroke can be ordered the same as the standard stroke. MY1M20-3000L-M9BW

* Please be advised that with a stroke of 49 mm or less, there are cases where auto switch mounting is not possible, and the performance of the air cushion may decline.

⑤ Stroke adjustment unit symbol

For stroke adjustment units, refer to page 44.

⑥ Auto switch

Nil	Without auto switch (Built-in magnet)
-----	---------------------------------------

Applicable auto switches vary depending on the bore size. Select an applicable one referring to the table below.

⑦ Number of auto switches

Nil	2
S	1
n	n

⑧ Made to Order Common Specifications

Refer to page 44 for details.

Applicable Auto Switches/Refer to the Web Catalog for further information on auto switches.

Type	Special function	Electrical entry	Indicator/light	Wiring (Output)	Load voltage		Auto switch model			Lead wire length [m]				Pre-wired connector	Applicable load			
					DC	AC	Perpendicular	In-line	0.5 (Nil)	1 (M)	3 (L)	5 (Z)						
													ø16, ø20				ø25 to ø63	ø16, ø20
Solid state auto switch	Diagnostic indication (2-color indicator)	Grommet	Yes	3-wire (NPN)	24 V	5 V, 12 V	—	M9NV	M9N	●	●	●	○	IC circuit	Relay, PLC			
				3-wire (PNP)				M9PV	M9P	●	●	●	○					
				2-wire				M9BV	M9B	●	●	●	○					
				3-wire (NPN)				M9NWV	M9NW	●	●	●	○					
	Water resistant (2-color indicator)			3-wire (PNP)	M9PWV	M9PW	●	●	●	○								
				2-wire	M9B WV	M9B W	●	●	●	○								
				3-wire (NPN)	M9NAV* ¹	M9NA* ¹	○	○	●	○								
				3-wire (PNP)	M9PAV* ¹	M9PA* ¹	○	○	●	○								
2-wire	M9BAV* ¹	M9BA* ¹	○	○	●	○												
Reed auto switch	—	Grommet	No	3-wire (NPN equivalent)	—	5 V	—	A96V	—	A96	Z76	●	—	—	—	IC circuit	—	
				2-wire	24 V	12 V	100 V	A93V* ²	—	A93	Z73	●	●	●	●	—	—	—
						100 V or less		A90V	—	A90	Z80	●	—	●	—	—	IC circuit	—

*¹ Water-resistant type auto switches can be mounted on the above models, but SMC cannot guarantee water resistance.

Please contact SMC regarding water-resistant types with the above model numbers.

*² The 1 m lead wire is only applicable to the D-A93.

* For details on auto switch mounting brackets and part numbers, refer to page 112.

* Lead wire length symbols: 0.5 m Nil (Example) M9NW 3 m L (Example) M9NWL
1 m M (Example) M9NWM 5 m Z (Example) M9NWZ

* Solid state auto switches marked with "○" are produced upon receipt of order.

* Since there are applicable auto switches other than those listed above, refer to page 112 for details.

* Auto switches are shipped together with the product but do not come assembled. (Refer to page 109 for the details of auto switch mounting.)

Mechanically Jointed Rodless Cylinder Slide Bearing Guide Type **MY1M Series**

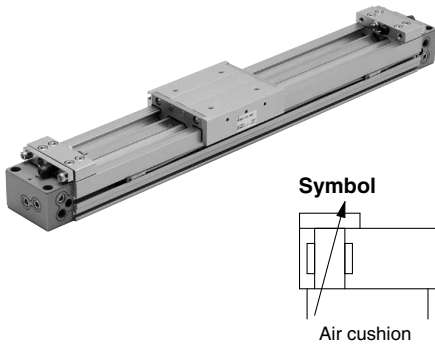

Symbol

Air cushion



Made to Order Common Specifications
(For details, refer to page 114.)

Symbol	Specifications
-XB22*1	Shock absorber soft type RJ series mounted
-XC67	NBR rubber lining in dust seal band
-X168	Helical insert thread specifications

*1 Excludes ø50 and ø63 for the -XB22

Specifications

Bore size [mm]	16	20	25	32	40	50	63
Fluid	Air						
Action	Double acting						
Operating pressure range	0.2 to 0.8 MPa			0.15 to 0.8 MPa			
Proof pressure	1.2 MPa						
Ambient and fluid temperatures	5 to 60°C						
Cushion	Air cushion						
Lubrication	Non-lube						
Stroke length tolerance	1000 or less $^{+1.8}_0$ 1001 to 3000 $^{+2.8}_0$		2700 or less $^{+1.8}_0$, 2701 to 5000 $^{+2.8}_0$				
Piping port size	Front/Side port	M5 x 0.8		1/8	1/4	3/8	
	Bottom port	ø4		ø6	ø8	ø10	

Piston Speed

Bore size [mm]		16 to 63
Without stroke adjustment unit		100 to 1000 mm/s
Stroke adjustment unit	A unit	100 to 1000 mm/s*1
	L unit and H unit	100 to 1500 mm/s*2

*1 Be aware that when the stroke adjustment range is increased with the adjustment bolt, the air cushion capacity decreases. Also, when exceeding the air cushion stroke ranges on page 46, the piston speed should be 100 to 200 mm/s.

*2 The piston speed is 100 to 1000 mm/s for centralized piping.

* Use at a speed within the absorption capacity range. Refer to page 46.

* Due to the construction of this product, it may have more fluctuation in operating speed compared to a rod type air cylinder. For applications that require constant speed, select the equipment corresponding to the required level.

Stroke Adjustment Unit Specifications

Bore size [mm]		16			20			25			32			40			50			63		
Unit symbol		A	L	H	A	L	H	A	L	H	A	L	H	A	L	H	A	L	H			
Configuration Shock absorber model	Without spacer	With adjustment bolt RB 0806	With adjustment bolt RB 0806 + with adjustment bolt	With adjustment bolt RB 1007 + with adjustment bolt	With adjustment bolt RB 1007	With adjustment bolt RB 1412 + with adjustment bolt	With adjustment bolt RB 1412 + with adjustment bolt	With adjustment bolt RB 1412	With adjustment bolt RB 2015 + with adjustment bolt	With adjustment bolt RB 2015 + with adjustment bolt	With adjustment bolt RB 1412	With adjustment bolt RB 2015 + with adjustment bolt	With adjustment bolt RB 2015 + with adjustment bolt	With adjustment bolt RB 2015	With adjustment bolt RB 2725 + with adjustment bolt	With adjustment bolt RB 2725 + with adjustment bolt	With adjustment bolt RB 2015 + with adjustment bolt	With adjustment bolt RB 2015 + with adjustment bolt	With adjustment bolt RB 2725 + with adjustment bolt			
	With short spacer	-5.6 to -11.2	-6 to -12	-11.5 to -23	-12 to -24	-16 to -32	-20 to -40	-25 to -50														
	With long spacer	-11.2 to -16.8	-12 to -18	-23 to -34.5	-24 to -36	-32 to -48	-40 to -60	-50 to -75														
Stroke adjustment range by intermediate fixing spacer [mm]	Without spacer	0 to -5.6	0 to -6	0 to -11.5	0 to -12	0 to -16	0 to -20	0 to -25														

* Stroke adjustment range is applicable for one side when mounted on a cylinder.

Stroke Adjustment Unit Symbol

		Right side stroke adjustment unit											
		Without unit	A: With adjustment bolt		L: With low load shock absorber + Adjustment bolt		H: With high load shock absorber + Adjustment bolt		Without unit		Without unit		
Left side stroke adjustment unit	Without unit	Nil	SA	SA6	SA7	SL	SL6	SL7	SH	SH6	SH7		
	A: With adjustment bolt	AS	A	AA6	AA7	AL	AL6	AL7	AH	AH6	AH7		
With short spacer		A6S	A6A	A6	A6A7	A6L	A6L6	A6L7	A6H	A6H6	A6H7		
With long spacer		A7S	A7A	A7A6	A7	A7L	A7L6	A7L7	A7H	A7H6	A7H7		
L: With low load shock absorber + Adjustment bolt	LS	LA	LA6	LA7	L	LL6	LL7	LH	LH6	LH7			
	With short spacer	L6S	L6A	L6A6	L6A7	L6L	L6	L6L7	L6H	L6H6	L6H7		
	With long spacer	L7S	L7A	L7A6	L7A7	L7L	L7L6	L7	L7H	L7H6	L7H7		
H: With high load shock absorber + Adjustment bolt	HS	HA	HA6	HA7	HL	HL6	HL7	H	HH6	HH7			
	With short spacer	H6S	H6A	H6A6	H6A7	H6L	H6L6	H6L7	H6H	H6	H6H7		
	With long spacer	H7S	H7A	H7A6	H7A7	H7L	H7L6	H7L7	H7H	H7H6	H7		

* Spacers are used to fix the stroke adjustment unit at an intermediate stroke position.

For details on spacers and stroke adjustment units, refer to "Accessory Brackets (Option)" on page 54.

* For precautions, refer to page 121.

Accessory Brackets (Option)

Stroke adjustment unit	p. 54
Side support	p. 55

Refer to pages 109 to 112 for the specifications with auto switch.

Stroke adjustment unit mounting diagram

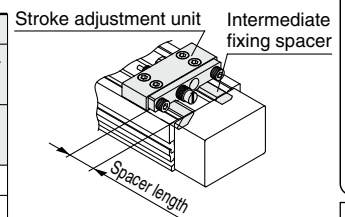

Example of L6L7 attachment

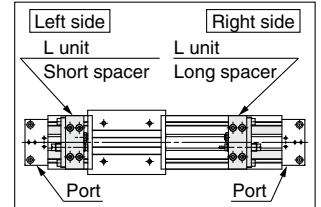

Model Selection

MY1B

MY1M

MY1C

MY1H

MY1HT

Auto Switch Mounting

Made to Order Common Specifications

Specific Product Precautions

MY1M Series

Shock Absorbers for L and H Units

Type	Stroke adjustment unit	Bore size [mm]						
		16	20	25	32	40	50	63
Standard (Shock absorber/RB series)	L	RB0806		RB1007	RB1412		RB2015	
	H	—	RB1007	RB1412	RB2015		RB2725	
Shock absorber/soft type RJ series mounted (-XB22)	L	RJ0806H		RJ1007H	RJ1412H		—	—
	H	—	RJ1007H	RJ1412H	—	—	—	—

- * The shock absorber service life is different from that of the MY1M cylinder depending on operating conditions. Refer to the RB/RJ Series Specific Product Precautions for the replacement period.
- * Shock absorber soft type RJ series mounted (-XB22) is made-to-order common specifications. For details, refer to page 115.

Shock Absorber Specifications

Model	RB 0806	RB 1007	RB 1412	RB 2015	RB 2725	
Max. absorbed energy [J]	2.9	5.9	19.6	58.8	147	
Stroke absorption [mm]	6	7	12	15	25	
Max. collision speed [mm/s]	1500					
Max. operating frequency [cycle/min]	80	70	45	25	10	
Spring force [N]	Extended	1.96	4.22	6.86	8.34	8.83
	Retracted	4.22	6.86	15.98	20.50	20.01
Operating temperature range [°C]	5 to 60					

- * The shock absorber service life is different from that of the MY1M cylinder depending on operating conditions. Refer to the RB Series Specific Product Precautions for the replacement period.

Theoretical Output

Bore size [mm]	Piston area [mm ²]	Operating pressure [MPa]						
		0.2	0.3	0.4	0.5	0.6	0.7	0.8
16	200	40	60	80	100	120	140	160
20	314	62	94	125	157	188	219	251
25	490	98	147	196	245	294	343	392
32	804	161	241	322	402	483	563	643
40	1256	251	377	502	628	754	879	1005
50	1962	392	588	784	981	1177	1373	1569
63	3115	623	934	1246	1557	1869	2180	2492

- * Theoretical output [N] = Pressure [MPa] x Piston area [mm²]

Weight

Bore size [mm]	Basic weight	Additional weight per each 50 mm of stroke	Weight of moving parts	Side support bracket weight (per set) Type A and B	Stroke adjustment unit weight (per unit)		
					A unit weight	L unit weight	H unit weight
16	0.67	0.12	0.19	0.01	0.03	0.04	—
20	1.11	0.16	0.28	0.02	0.04	0.05	0.08
25	1.64	0.24	0.39	0.02	0.07	0.11	0.18
32	3.27	0.38	0.81	0.04	0.14	0.23	0.39
40	5.88	0.56	1.41	0.08	0.25	0.34	0.48
50	10.06	0.77	2.51	0.08	0.36	0.51	0.81
63	16.57	1.11	3.99	0.17	0.68	0.83	1.08

Calculation: (Example) **MY1M25-300A**

- Basic weight..... 1.64 kg
- Cylinder stroke 300 mm stroke
- Additional weight..... 0.24/50 mm stroke
1.64 + 0.24 x 300/50 + 0.07 x 2 ≈ 3.22 kg
- Weight of A unit..... 0.07 kg

⚠ Precautions

For details on the MY1M Series Mechanically Jointed Rodless Cylinder, refer to “Specific Product Precautions” on pages 119 to 122.

Cushion Capacity

Cushion Selection

<Air cushion>

Air cushions are a standard feature on mechanically jointed rodless cylinders. The air cushion mechanism is incorporated to prevent excessive impact of the piston with high kinetic energy at the stroke end. The purpose of air cushion, thus, is not to decelerate the piston near the stroke end. The ranges of load and speed that air cushions can absorb are within the air cushion limit lines shown in the graphs.

<Stroke adjustment unit with shock absorber>

Use this unit when operating with a load and speed exceeding the air cushion limit line, or when cushioning is required outside of the effective air cushion stroke range due to stroke adjustment.

L unit

Use this unit when cushioning is required outside of the effective air cushion range even if the load and speed are within the air cushion limit line, or when the cylinder is operated in a load and speed range above the air cushion limit line and below the L unit limit line.

H unit

Use this unit when the cylinder is operated in a load and speed range above the L unit limit line and below the H unit limit line.

* For details on stroke adjustment using the adjustment bolt, refer to page 121.

Air Cushion Stroke

[mm]

Bore size [mm]	Cushion stroke
16	12
20	15
25	15
32	19
40	24
50	30
63	37

Absorption Capacity of Air Cushion and Stroke Adjustment Units

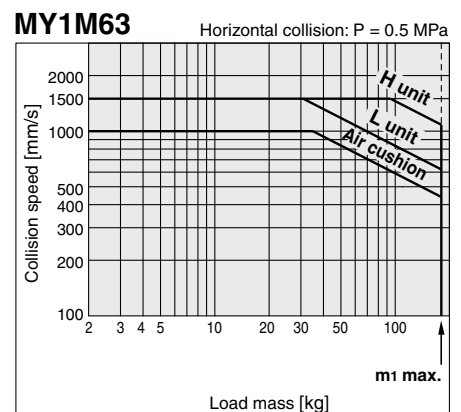
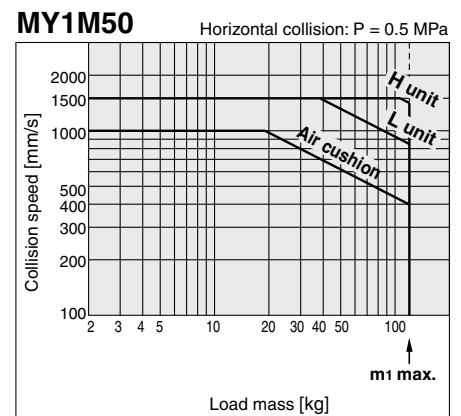
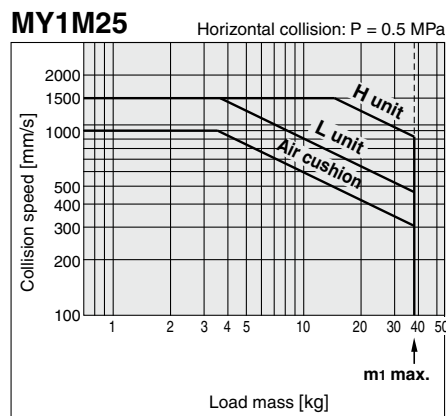
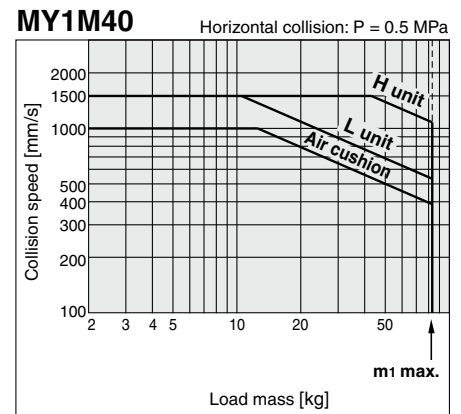
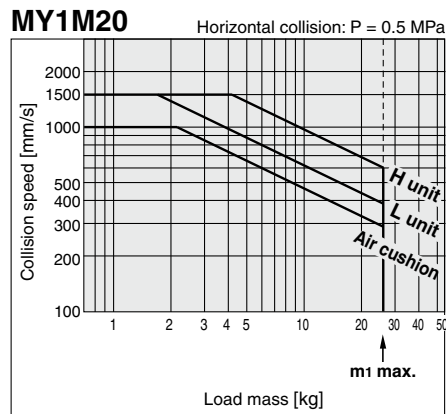
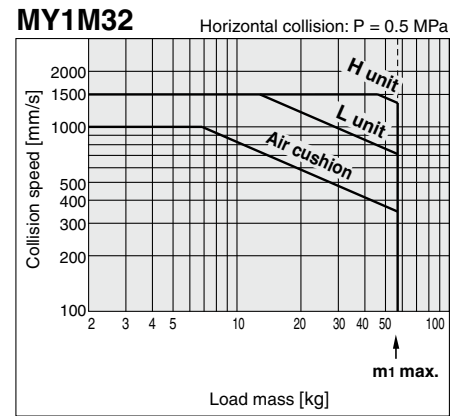
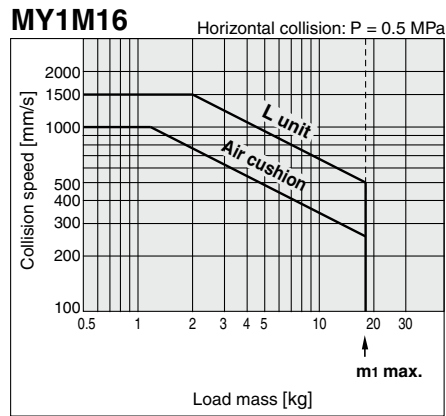

Model Selection

MY1B

MY1M

MY1C

MY1H

MY1HT

Auto Switch Mounting

Made to Order Common Specifications

Specific Product Precautions

MY1M Series

Construction: $\varnothing 16$ to $\varnothing 63$

MY1M16 to 63

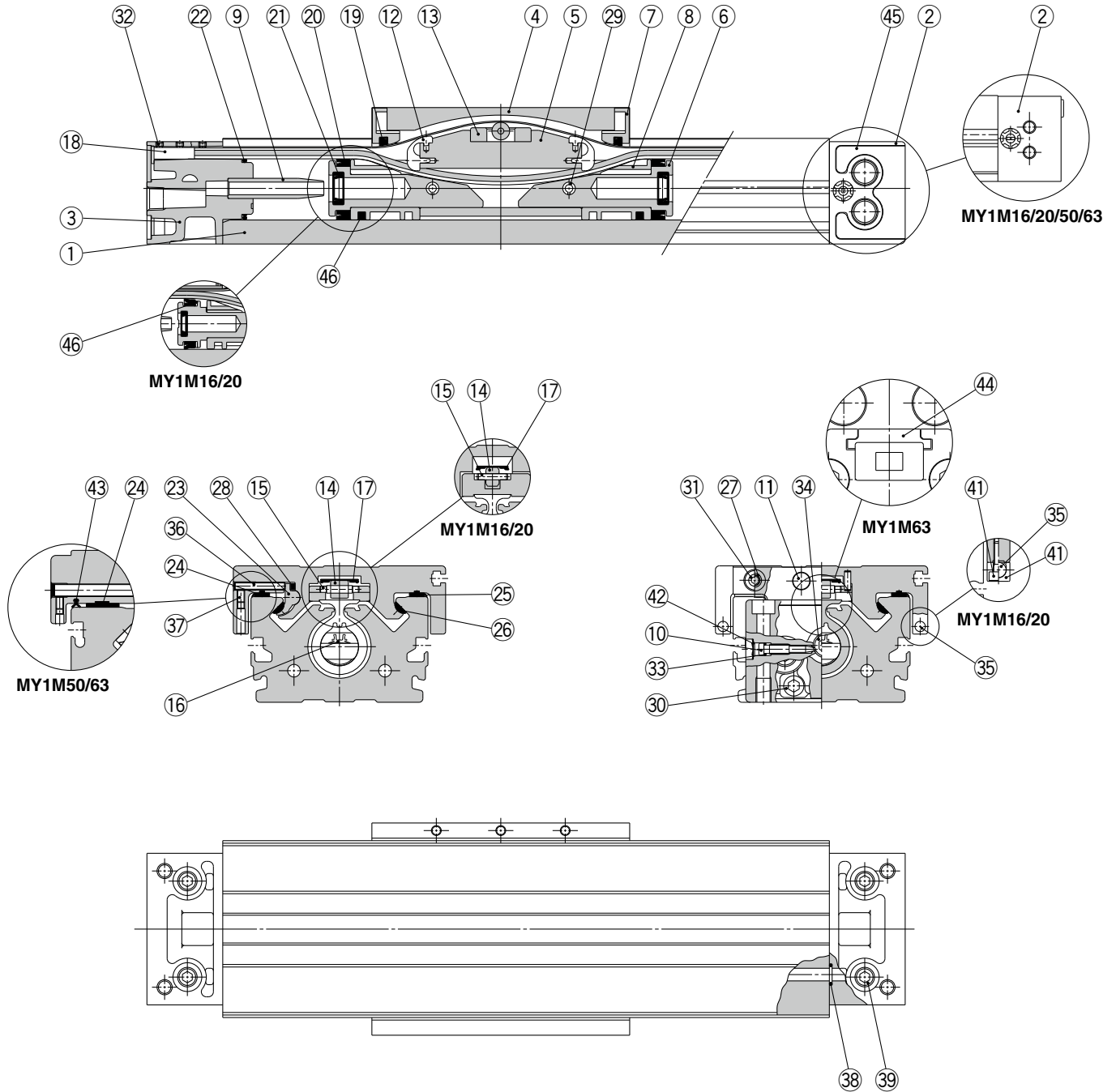

MY1M16 to 63

Component Parts

No.	Description	Material	Note
1	Cylinder tube	Aluminum alloy	Hard anodized
2	Head cover WR	Aluminum alloy	Painted
3	Head cover WL	Aluminum alloy	Painted
4	Slide table	Aluminum alloy	Hard anodized
5	Piston yoke	Aluminum alloy	Chromated
6	Piston	Aluminum alloy	Chromated
7	End cover	Special resin	
8	Wear ring	Special resin	
9	Cushion ring	Aluminum alloy	Anodized
10	Cushion needle	Rolled steel	Nickel plating
11	Stopper	Carbon steel	Nickel plating
12	Belt separator	Special resin	
13	Coupler	Sintered iron material	
14	Guide roller	Special resin	
15	Guide roller shaft	Stainless steel	
18	Belt clamp	Special resin	
23	Adjusting arm	Aluminum alloy	Chromated
24	Bearing R	Special resin	
25	Bearing L	Special resin	
26	Bearing S	Special resin	

No.	Description	Material	Note
27	Spacer	Stainless steel	
28	Backup spring	Stainless steel	
29	Spring pin	Carbon tool steel	
30	Hexagon socket head cap screw	Chromium molybdenum steel	Chromated
31	Hexagon socket button head screw	Chromium molybdenum steel	Chromated
32	Hexagon socket head set screw	Chromium molybdenum steel	Black zinc chromated/Chromated
34	Hexagon socket head taper plug	Carbon steel	Chromated
35	Magnet	—	
36	Hexagon socket head set screw	Chromium molybdenum steel	Black zinc chromated
37	Hexagon socket head set screw	Chromium molybdenum steel	Black zinc chromated
39	Hexagon socket head taper plug	Carbon steel	Chromated
40	Magnet holder	Special resin	(ø16, ø20)
41	Hexagon socket head cap screw	Chromium molybdenum steel	Nickel plating
42	Type CR retaining ring	Spring steel	
44	Head plate	Aluminum alloy	Hard anodized (ø63)
45	Port cover	Special resin	(ø25 to ø40)
46	Lube-retainer	Special resin	

Replacement Parts/Seal Kit

No.	Description	Qty.	MY1M16	MY1M20	MY1M25	MY1M32	MY1M40	MY1M50	MY1M63
16	Seal belt	1	MY16-16C-Stroke	MY20-16C-Stroke	MY25-16C-Stroke	MY32-16C-Stroke	MY40-16C-Stroke	MY50-16C-Stroke	MY63-16A-Stroke
17	Dust seal band	1	MY16-16B-Stroke	MY20-16B-Stroke	MY25-16B-Stroke	MY32-16B-Stroke	MY40-16B-Stroke	MY50-16B-Stroke	MY63-16B-Stroke
33	O-ring	2	KA00309 (ø4 x ø1.8 x ø1.1)	KA00311 (ø5.1 x ø3 x ø1.05)	KA00311 (ø5.1 x ø3 x ø1.05)	KA00320 (ø7.15 x ø3.75 x ø1.7)	KA00402 (ø8.3 x ø4.5 x ø1.9)	KA00777 —	KA00777 —
43	Side scraper	2	—	—	—	—	—	MYM50-15CK0502B	MYM63-15CK0503B
19	Scraper	2							
20	Piston seal	2							
21	Cushion seal	2	MY1M16-PS	MY1M20-PS	MY1M25-PS	MY1M32-PS	MY1M40-PS	MY1M50-PS	MY1M63-PS
22	Tube gasket	2							
38	O-ring	4							

* Seal kit includes (19), (20), (21), (22), and (38). Order the seal kit based on each bore size.

* Seal kit includes a grease pack (10 g).

When (16) and (17) are shipped independently, a grease pack is included. (10 g per 1000 mm stroke)
Order with the following part number when only the grease pack is needed.

Grease pack part number: GR-S-010 (10 g), GR-S-020 (20 g)

* Two types of dust seal bands are available. Since the part number varies depending on the treatment of the hexagon socket head set screw (32), please check a proper dust seal band carefully.

A: Black zinc chromated → MY□□-16B-stroke, B: Chromated → MY□□-16BW-stroke

Model Selection

MY1B

MY1M

MY1C

MY1H

MY1HT

Auto Switch Mounting

Made to Order Common Specifications

Specific Product Precautions

MY1M Series

Standard Type/Centralized Piping Type $\phi 16, \phi 20$

MY1M16□/20□ — Stroke

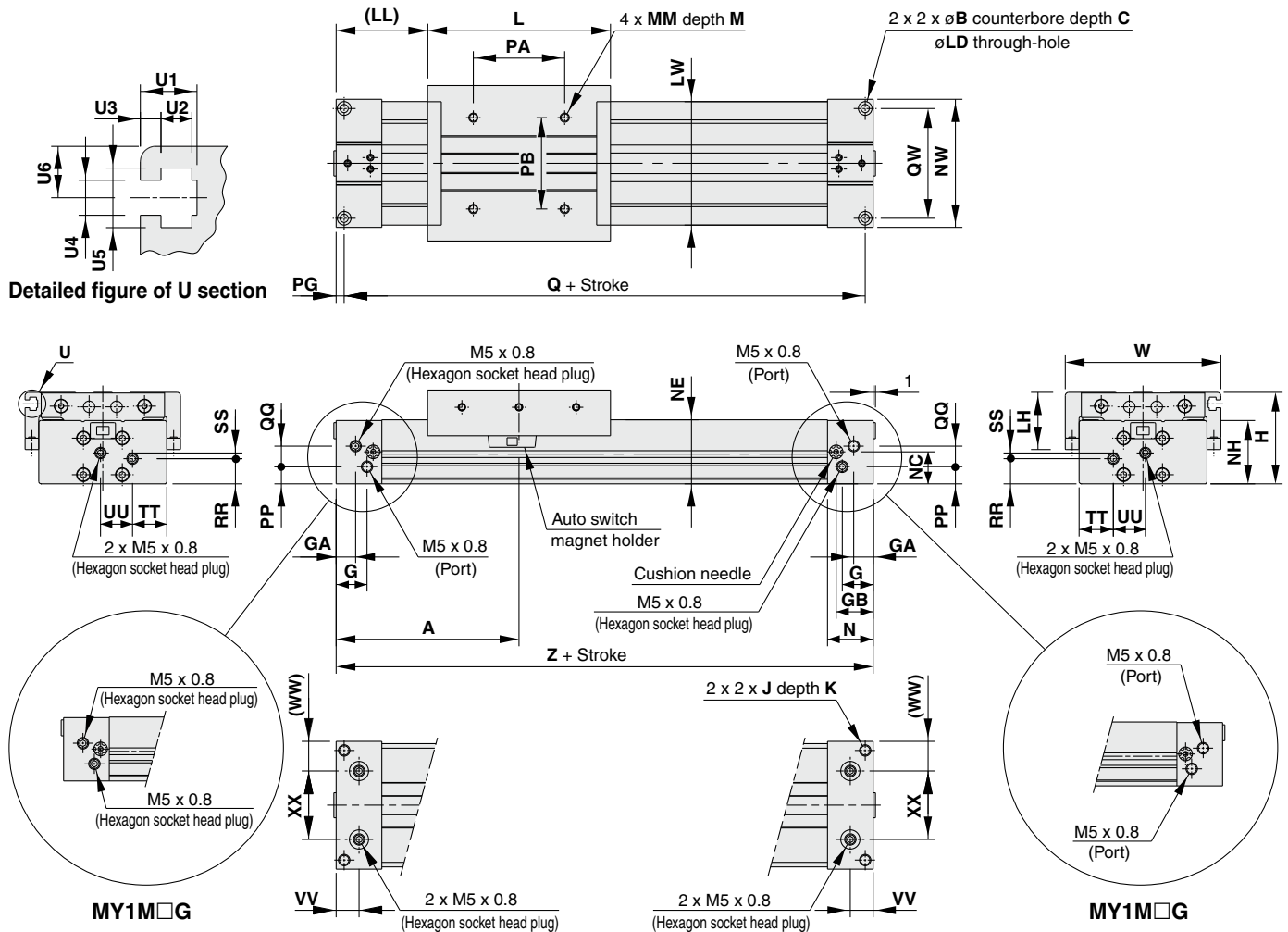

Model	A	B	C	G	GA	GB	H	J	K	L	LD	LH	LL	LW	M	MM	N	NC	NE	NH	NW	PA
MY1M16□	80	6	3.5	13.5	8.5	16.2	40	M5 x 0.8	10	80	3.6	22.5	40	54	6	M4 x 0.7	20	14	28	27.7	56	40
MY1M20□	100	7.5	4.5	12.5	12.5	20	46	M6 x 1	12	100	4.8	23	50	58	7.5	M5 x 0.8	25	17	34	33.7	60	50

Model	PB	PG	PP	Q	QQ	QW	RR	SS	TT	UU	VV	W	WW	XX	Z
MY1M16□	40	3.5	7.5	153	9	48	11	2.5	15	14	10	68	13	30	160
MY1M20□	40	4.5	11.5	191	10	45	14.5	5	18	12	12.5	72	14	32	200

Detailed Dimensions of U Section [mm]

Model	U1	U2	U3	U4	U5	U6
MY1M16□	5.5	3	2	3.4	5.8	5
MY1M20□	5.5	3	2	3.4	5.8	5.5

Centralized Piping on the Bottom

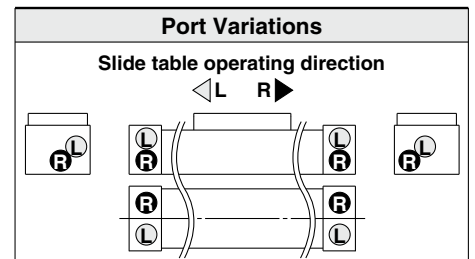
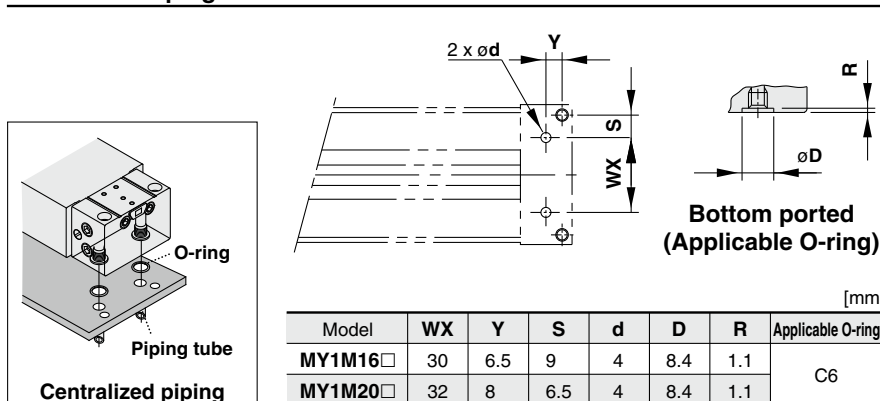

MY1M Series

Standard Type/Centralized Piping Type $\phi 50, \phi 63$

MY1M50□/60□ — Stroke

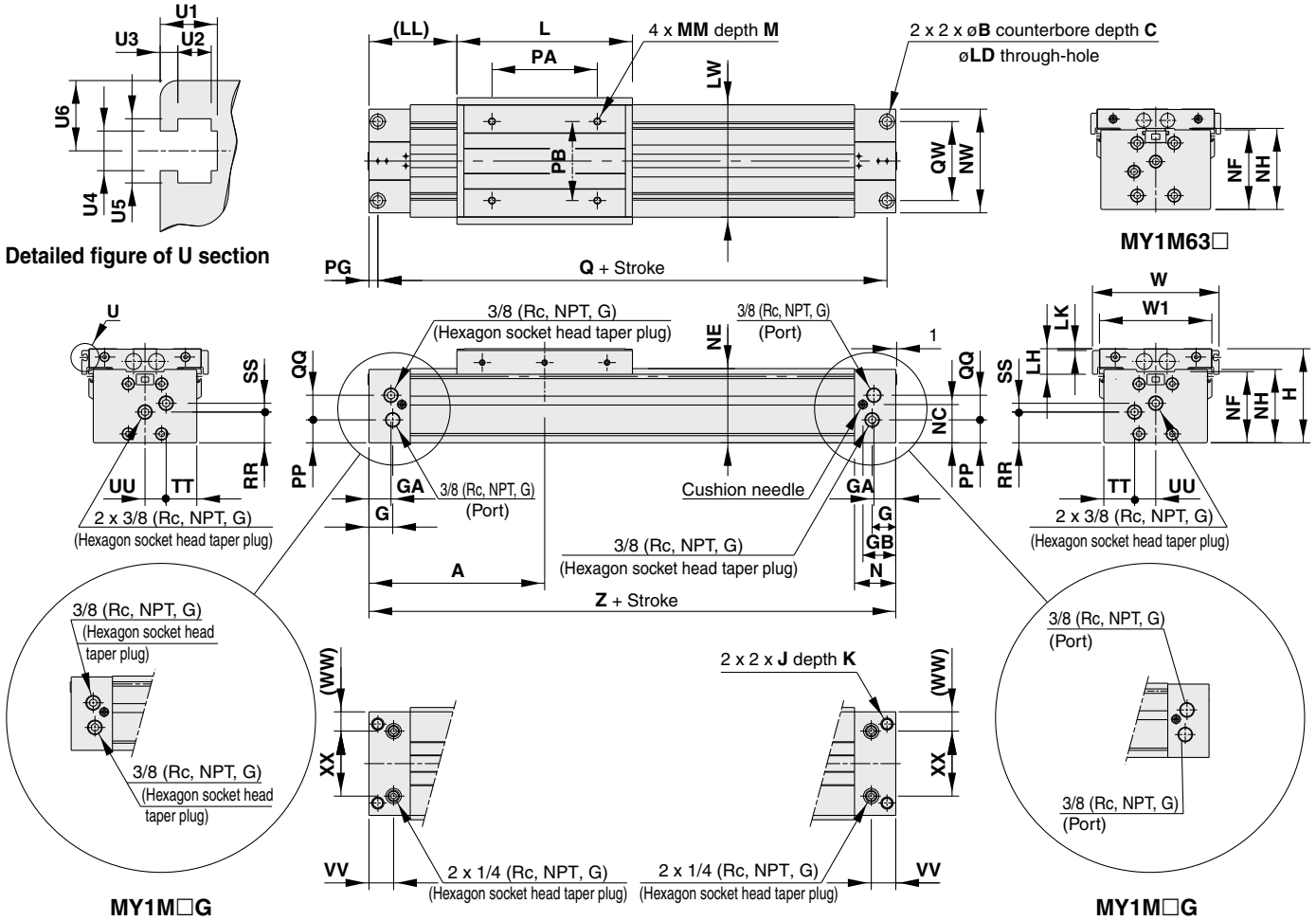

Model	A	B	C	G	GA	GB	H	J	K	L	LD	LH	LK	LL	LW	M	MM	N	NC	NE	NF	NH	NW	PA
MY1M50□	200	17	10.5	27	25	37.5	107	M14 x 2	28	200	11	29	2	100	128	15	M8 x 1.25	47	43.5	84.5	81	83.5	118	120
MY1M63□	230	19	12.5	29.5	27.5	39.5	130	M16 x 2	32	230	13.5	32.5	5.5	115	152	16	M10 x 1.5	50	56	104	103	105	142	140

Model	PB	PG	PP	Q	QQ	QW	RR	SS	TT	UU	VV	W	W1	WW	XX	Z
MY1M50□	90	10	26	380	28	90	35	10	35	24	28	144	128	22	74	400
MY1M63□	110	12	42	436	30	110	49	13	43	28	30	168	152	25	92	460

Model	U1	U2	U3	U4	U5	U6
MY1M50□	6.5	3.8	2	4.5	7.3	8
MY1M63□	8.5	5	2.5	5.5	8.4	8

Centralized Piping on the Bottom

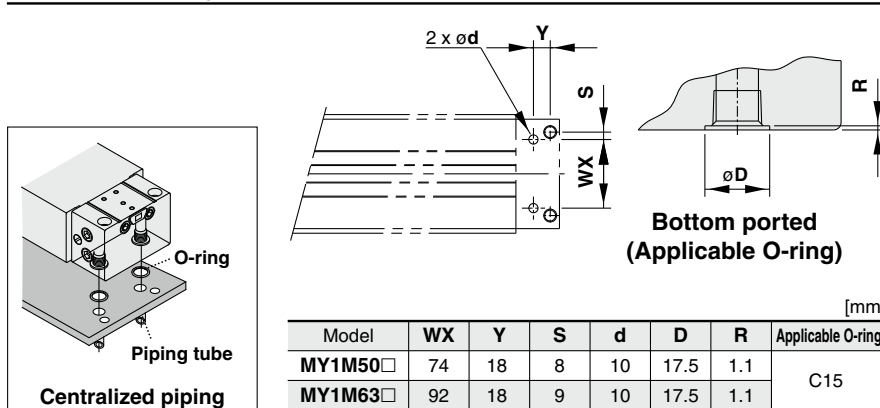

Model	WX	Y	S	d	D	R	Applicable O-ring
MY1M50□	74	18	8	10	17.5	1.1	C15
MY1M63□	92	18	9	10	17.5	1.1	

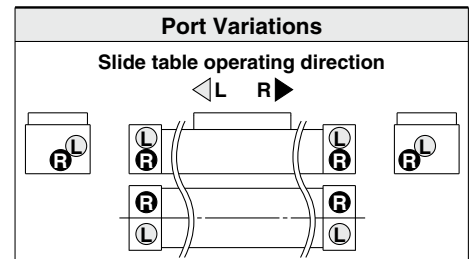

Stroke Adjustment Units

With adjustment bolt

MY1M Bore size — Stroke A

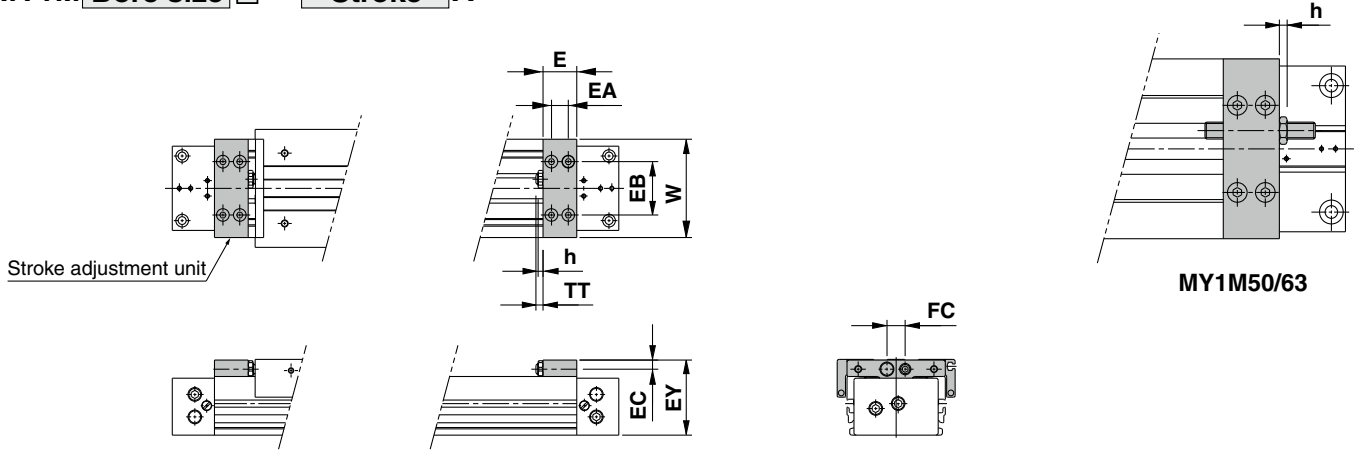

Applicable cylinder	E	EA	EB	EC	EY	FC	h	TT	W
MY1M16	14.6	7	30	5.8	39.5	14	3.6	5.4 (Max. 11)	58
MY1M20	20	10	32	5.8	45.5	14	3.6	5 (Max. 11)	58
MY1M25	24	12	38	6.5	53.5	13	3.5	5 (Max. 16.5)	70
MY1M32	29	14	50	8.5	67	17	4.5	8 (Max. 20)	88
MY1M40	35	17	57	10	83	17	4.5	9 (Max. 25)	104
MY1M50	40	20	66	14	106	26	5.5	13 (Max. 33)	128
MY1M63	52	26	77	14	129	31	5.5	13 (Max. 38)	152

With low load shock absorber + Adjustment bolt

MY1M Bore size — Stroke L

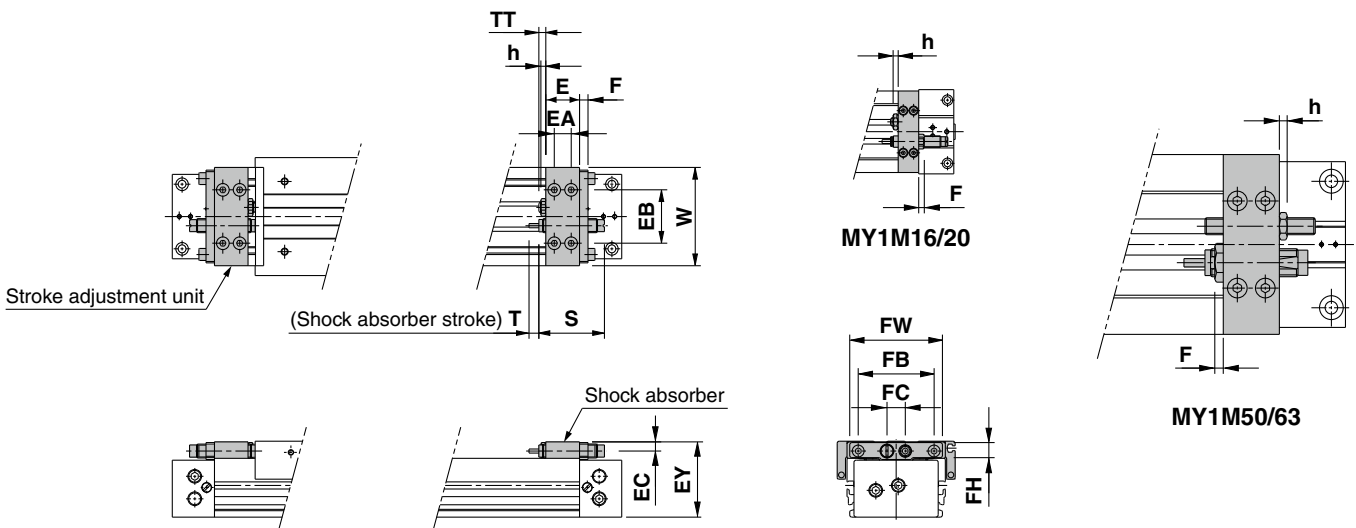

Applicable cylinder	E	EA	EB	EC	EY	F	FB	FC	FH	FW	h	S	T	TT	W	Shock absorber model
MY1M16	14.6	7	30	5.8	39.5	4	—	14	—	—	3.6	40.8	6	5.4 (Max. 11)	58	RB0806
MY1M20	20	10	32	5.8	45.5	4	—	14	—	—	3.6	40.8	6	5 (Max. 11)	58	RB0806
MY1M25	24	12	38	6.5	53.5	6	54	13	13	66	3.5	46.7	7	5 (Max. 16.5)	70	RB1007
MY1M32	29	14	50	8.5	67	6	67	17	16	80	4.5	67.3	12	8 (Max. 20)	88	RB1412
MY1M40	35	17	57	10	83	6	78	17	17.5	91	4.5	67.3	12	9 (Max. 25)	104	RB1412
MY1M50	40	20	66	14	106	6	—	26	—	—	5.5	73.2	15	13 (Max. 33)	128	RB2015
MY1M63	52	26	77	14	129	6	—	31	—	—	5.5	73.2	15	13 (Max. 38)	152	RB2015

Model Selection

MY1B

MY1M

MY1C

MY1H

MY1HT

Auto Switch Mounting

Made to Order Common Specifications

Specific Product Precautions

MY1M Series

Stroke Adjustment Units

With high load shock absorber + Adjustment bolt

MY1M — H

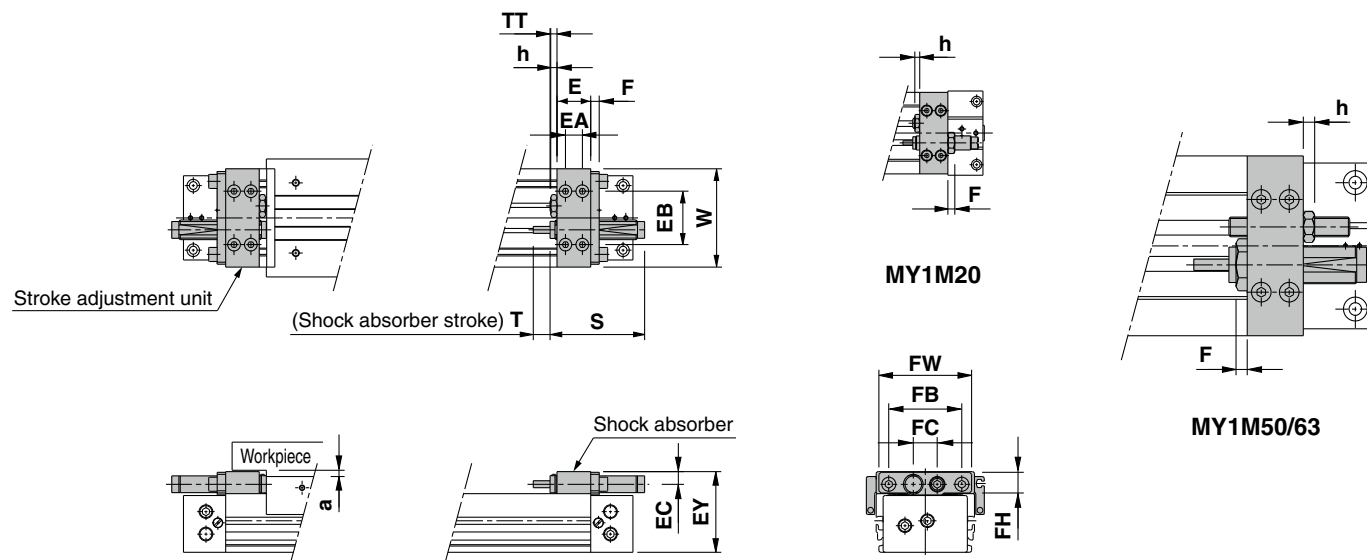

* Since the EY dimension of H unit is longer than the table top height (H dimension), when mounting a workpiece that exceeds the overall length (L dimension) of the slide table, allow a clearance of dimension "a" or longer on the workpiece side.

Applicable cylinder	E	EA	EB	EC	EY	F	FB	FC	FH	FW	h	S	T	TT	W	Shock absorber model	a
MY1M20	20	10	32	7.7	50	5	—	14	—	—	3.5	46.7	7	5 (Max. 11)	58	RB1007	5
MY1M25	24	12	38	9	57.5	6	52	17	16	66	4.5	67.3	12	5 (Max. 16.5)	70	RB1412	4.5
MY1M32	29	14	50	11.5	73	8	67	22	22	82	5.5	73.2	15	8 (Max. 20)	88	RB2015	6
MY1M40	35	17	57	12	87	8	78	22	22	95	5.5	73.2	15	9 (Max. 25)	104	RB2015	4
MY1M50	40	20	66	18.5	115	8	—	30	—	—	11	99	25	13 (Max. 33)	128	RB2725	9
MY1M63	52	26	77	19	138.5	8	—	35	—	—	11	99	25	13 (Max. 38)	152	RB2725	9.5

MY1M Series Accessory Brackets (Option)

Stroke Adjustment Units

MYM-A 25 L2-6N

Stroke adjustment unit

Bore size

16	16 mm
20	20 mm
25	25 mm
32	32 mm
40	40 mm
50	50 mm
63	63 mm

Intermediate fixing spacer

Nil	Without spacer
6	Short spacer
7	Long spacer

Spacer delivery type

Nil	Unit installed
N	Spacer only

- * Spacers are used to fix the stroke adjustment unit at an intermediate stroke position.
- * Spacers are shipped for a set of two.

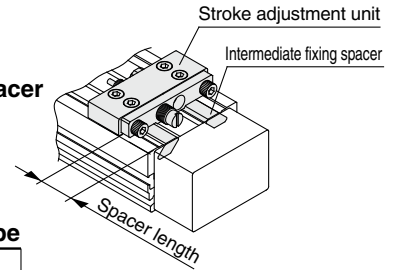

Unit no.

Symbol	Stroke adjustment unit	Mounting position
A1	A unit	Left
A2		Right
L1	L unit	Left
L2		Right
H1	H unit	Left
H2		Right

* A and L unit only for ø16

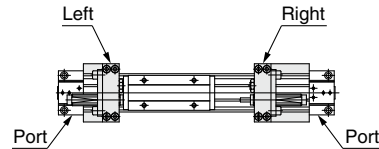

Stroke adjustment range

Bore size	16		20			25			32			40			50			63		
	A	L	A	L	H	A	L	H	A	L	H	A	L	H	A	L	H	A	L	H
Without spacer	0 to -5.6		0 to -6			0 to -11.5			0 to -12			0 to -16			0 to -20			0 to -25		
With short spacer	-5.6 to -11.2		-6 to -12			-11.5 to -23			-12 to -24			-16 to -32			-20 to -40			-25 to -50		
With long spacer	-11.2 to -16.8		-12 to -18			-23 to -34.5			-24 to -36			-32 to -48			-40 to -60			-50 to -75		

Spacer length

Bore size	16	20	25	32	40	50	63
Short spacer	5.6	6	11.5	12	16	20	25
Long spacer	11.2	12	23	24	32	40	50

Component Parts

<p>MYM-A25L2 (Without spacer)</p>	<p>MYM-A25L2-6 (With short spacer)</p>	<p>MYM-A25L2-7 (With long spacer)</p>	<p>MYM-A25L2-6N (Short spacer only)</p> <p>MYM-A25L2-7N (Long spacer only)</p>
--	---	--	--

MY1M Series

Side Supports

Side support A MY-S□A

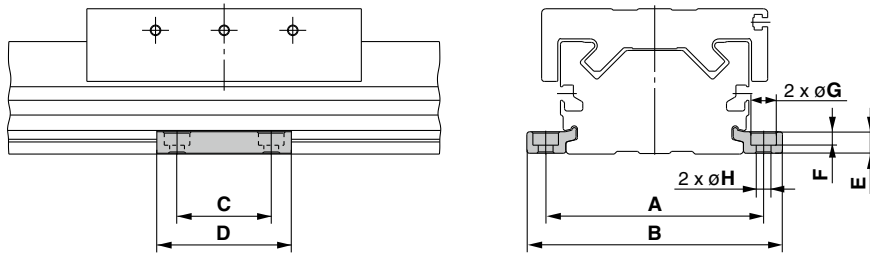

Side support B MY-S□B

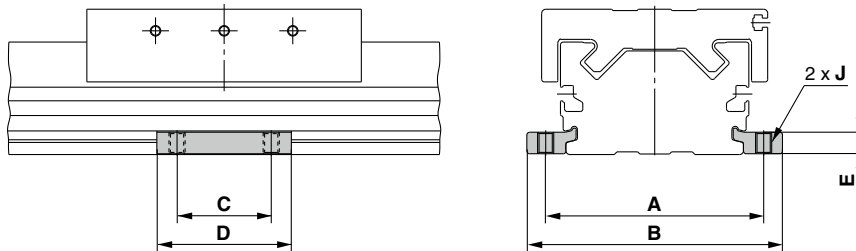

[mm]

Model	Applicable cylinder	A	B	C	D	E	F	G	H	J
MY-S16 ^A _B	MY1M16	61	71.6	15	26	4.9	3	6.5	3.4	M4 x 0.7
MY-S20 ^A _B	MY1M20	67	79.6	25	38	6.4	4	8	4.5	M5 x 0.8
MY-S25 ^A _B	MY1M25	81	95	35	50	8	5	9.5	5.5	M6 x 1
MY-S32 ^A _B	MY1M32	100	118	45	64	11.7	6	11	6.6	M8 x 1.25
MY-S40 ^A _B	MY1M40	120	142	55	80	14.8	8.5	14	9	M10 x 1.5
	MY1M50	142	164							
MY-S63 ^A _B	MY1M63	172	202	70	100	18.3	10.5	17.5	11.5	M12 x 1.75

* Side supports consist of a set of right and left brackets.

Guide for Side Support Application

For long stroke operation, the cylinder tube may be deflected depending on its own weight and the load. In such a case, use a side support in the middle section. The spacing (L) of the support must be no more than the values shown in the graph on the right.

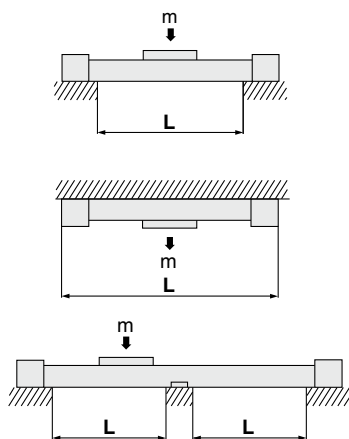

⚠ Caution

1. If the cylinder mounting surfaces are not measured accurately, using a side support may cause poor operation. Therefore, be sure to level the cylinder tube when mounting it. Also, for long stroke operation involving vibration and impact, the use of a side support is recommended even if the spacing value is within the allowable limits shown in the graph.
2. Support brackets are not for mounting; use them solely for providing support.

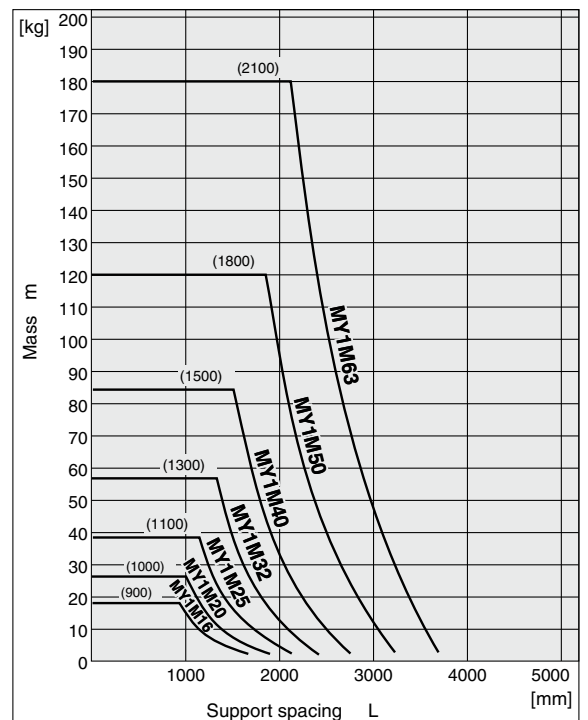

MY1 Series Auto Switch Mounting

Proper Auto Switch Mounting Position (Detection at Stroke End)

MY1B (Basic type) ø10 to ø20

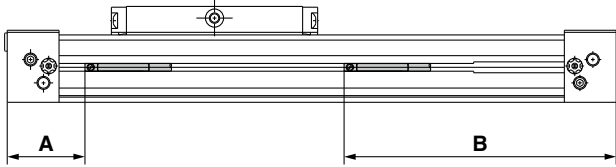

ø25 to ø100

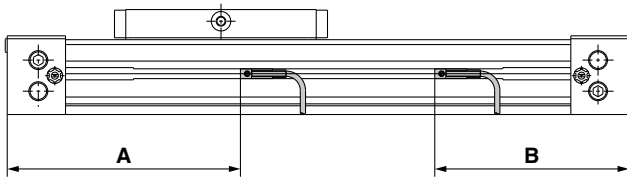

Proper Auto Switch Mounting Position [mm]

Auto switch model	D-M9□ D-M9□V D-M9□W D-M9□WV D-M9□A D-M9□AV		D-A9□ D-A9□V		D-Y59□/Y7P D-Y69□/Y7PV D-Y7□W D-Y7□WV D-Y7BA D-Z7□/Z80	
	A	B	A	B	A	B
Bore size						
10	24	86	20	90	—	—
16	31.5	128.5	27.5	132.5	—	—
20	39	161	35	165	—	—
25	138	82	134	86	—	—
32	186.5	93.5	182.5	97.5	—	—
40	222.5	117.5	218.5	212.5	—	—
50	—	—	—	—	272.5	127.5
63	322.5	137.5	—	—	317.5	142.5
80	489.5	200.5	—	—	484.5	205.5
100	574.5	225.5	—	—	569.5	230.5

* D-M9□□□ type cannot be mounted on ø50.

* Adjust the auto switch after confirming the operating condition in the actual setting.

MY1M (Slide bearing guide type) ø16, ø20

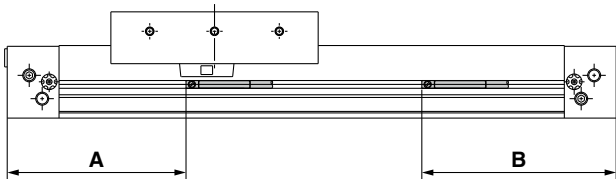

ø25 to ø63

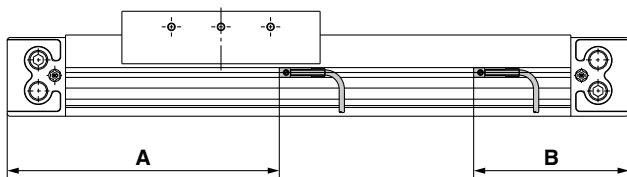

Proper Auto Switch Mounting Position [mm]

Auto switch model	D-M9□ D-M9□V D-M9□W D-M9□WV D-M9□A D-M9□AV		D-A9□ D-A9□V		D-Y59□/Y7P D-Y69□/Y7PV D-Y7□W D-Y7□WV D-Z7□/Z80	
	A	B	A	B	A	B
Bore size						
16	74	86	70	90	—	—
20	94	106	90	110	—	—
25	143.5	75.5	—	—	139.5	80.5
32	189.5	90.5	—	—	184.5	95.5
40	234.5	105.5	—	—	229.5	110.5
50	283.5	116.5	—	—	278.5	121.5
63	328.5	131.5	—	—	323.5	136.5

* Adjust the auto switch after confirming the operating condition in the actual setting.

MY1C (Cam follower guide type) ø16, ø20

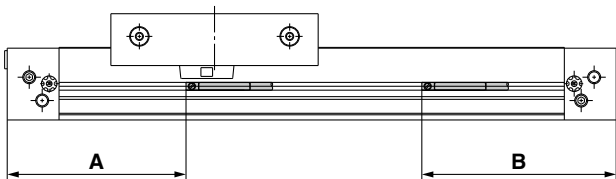

ø25 to ø63

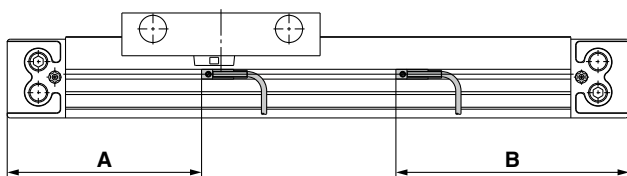

Proper Auto Switch Mounting Position [mm]

Auto switch model	D-M9□ D-M9□V D-M9□W D-M9□WV D-M9□A D-M9□AV		D-A9□ D-A9□V		D-Y59□/Y7P D-Y69□/Y7PV D-Y7□W D-Y7□WV D-Z7□/Z80	
	A	B	A	B	A	B
Bore size						
16	74	86	70	90	—	—
20	94	106	90	110	—	—
25	102	118	—	—	97	123
32	132	148	—	—	127	153
40	162.5	175.5	—	—	157.5	182.5
50	283.5	116.5	—	—	278.5	121.5
63	328.5	131.5	—	—	323.5	136.5

* Adjust the auto switch after confirming the operating condition in the actual setting.

Proper Auto Switch Mounting Position (Detection at Stroke End)

MY1H (Linear guide type)

ø10 to ø20

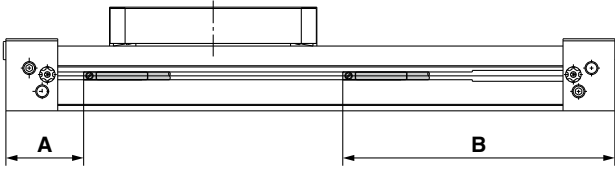

ø25 to ø40

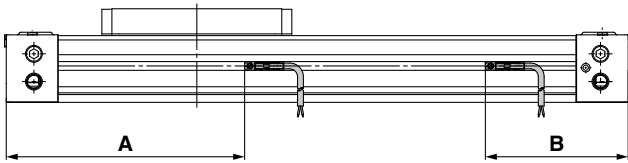

Proper Auto Switch Mounting Position [mm]

Auto switch model	D-M9□ D-M9□V D-M9□W D-M9□WV D-M9□A D-M9□AV		D-A9□ D-A9□V		D-Y59□/Y7P D-Y69□/Y7PV D-Y7□W D-Y7□WV D-Z7□/Z80	
	A	B	A	B	A	B
Bore size						
10	24	86	20	90	—	—
16	31.5	128.5	27.5	132.5	—	—
20	39	161	35	165	—	—
25	138	82	134	86	—	—
32	186.5	93.5	182.5	97.5	—	—
40	222.5	117.5	218.5	121.5	—	—

* Adjust the auto switch after confirming the operating condition in the actual setting.

MY1HT (High rigidity/Linear guide type)

ø50, ø63

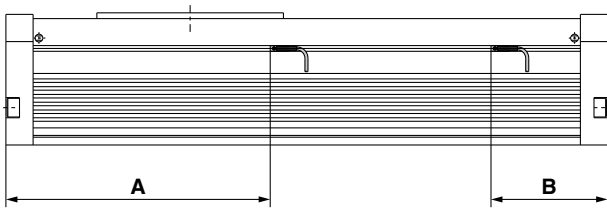

Proper Auto Switch Mounting Position [mm]

Auto switch model	D-Y59□/Y7P D-Y69□/Y7PV D-Y7□W D-Y7□WV D-Y7BA D-Z7□/Z80	
	A	B
Bore size		
50	290.5	123.5
63	335.5	138.5

* Adjust the auto switch after confirming the operating condition in the actual setting.

Model Selection

MY1B

MY1M

MY1C

MY1H

MY1HT

Auto Switch Mounting

Made to Order Common Specifications

Specific Product Precautions

MY1 Series

Operating Range

* Values which include hysteresis are for reference purpose only. They are not a guarantee (assuming approximately $\pm 30\%$ dispersion) and may change substantially depending on the ambient environment.

MY1B (Basic type)

[mm]

Auto switch model	Bore size									
	10	16	20	25	32	40	50	63	80	100
D-M9□/M9□V D-M9□W/M9□WV D-M9□A/M9□AV	3.5	4	5.5	5.0	5.5	5.5	—	12	12	11.5
D-A9□/A9□V	6	6.5	8.5	7.0	10.0	9.0	—	—	—	—
D-Z7□/Z80	—	—	—	—	—	—	11.5	11.5	11.5	11.5
D-Y59□/Y69□ D-Y7P/Y7PV D-Y7□W/Y7□WV	—	—	—	—	—	—	3.5	3.5	3.5	3.5

* D-M9□□□ type cannot be mounted on $\phi 50$.

MY1H (Linear guide type)

[mm]

Auto switch model	Bore size					
	10	16	20	25	32	40
D-M9□/M9□V D-M9□W/M9□WV D-M9□A/M9□AV	3	4.5	5	5.0	5.5	5.5
D-A9□/A9□V	11	6.5	8.5	7.0	10.0	9.0
D-Z7□/Z80	—	—	—	—	—	—
D-Y59□/Y69□ D-Y7P/Y7PV D-Y7□W/Y7□WV	—	—	—	—	—	—

MY1M (Slide bearing guide type)

[mm]

Auto switch model	Bore size						
	16	20	25	32	40	50	63
D-M9□/M9□V D-M9□W/M9□WV D-M9□A/M9□AV	7.5	7.5	8.5	8.5	9.5	7	6
D-A9□/A9□V	11	7.5	—	—	—	—	—
D-Z7□/Z80	—	—	12	12	12	11.5	11.5
D-Y59□/Y69□ D-Y7P/Y7PV D-Y7□W/Y7□WV	—	—	5	5	5	5.5	5.5

MY1C (Cam follower guide type)

[mm]

Auto switch model	Bore size						
	16	20	25	32	40	50	63
D-M9□/M9□V D-M9□W/M9□WV D-M9□A/M9□AV	7.5	7.5	7	8	8.5	7	6
D-A9□/A9□V	11	7.5	—	—	—	—	—
D-Z7□/Z80	—	—	12	12	12	11.5	11.5
D-Y59□/Y69□ D-Y7P/Y7PV D-Y7□W/Y7□WV	—	—	5	5	5	5.5	5.5

MY1HT

(High rigidity/Linear guide type) [mm]

Auto switch model	Bore size	
	50	63
D-Z7□/Z80	11	11
D-Y59□/Y69□ D-Y7P/Y7PV D-Y7□W/Y7□WV D-Y7BA	5	5

Auto Switch Mounting Bracket/Part No.

Auto switch model	Bore size [mm]	
	MY1B, MY1H	
	ø10 to ø20	ø50 to ø100
D-M9□/M9□V D-M9□W/M9□WV D-M9□A/M9□AV D-A9□/A9□V	—	BMG2-012

- * The D-M9□(V)/M9□W(V)/M9□A(V) are not available for bore size ø50 of the MY1B.
- * The D-A9□(V) is not available for bore sizes ø50 to ø100 of the MY1B.
- * There are no bore sizes ø50 to ø100 for the MY1H.

Auto switch model	Bore size [mm]	
	MY1B-Z, MY1H-Z	
	ø25 to ø40	
D-A9□/A9□V D-M9□/M9□V D-M9□W/M9□WV D-M9□A/M9□AV	BMY3-016	

Auto switch model	Bore size [mm]	
	MY1M, MY1C	
	ø10 to ø20	ø25 to ø63
D-M9□/M9□V D-M9□W/M9□WV D-M9□A/M9□AV D-A9□/A9□V	—	BMG2-012

- * The D-A9□(V) is not available for bore sizes ø25 to ø63.

ø25 to ø100: M9□(V)/M9□W(V)/M9□A(V)

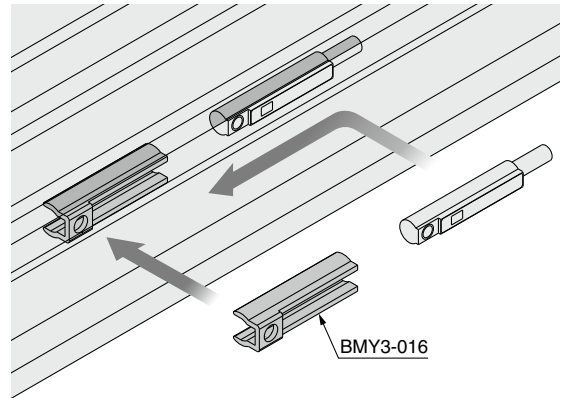
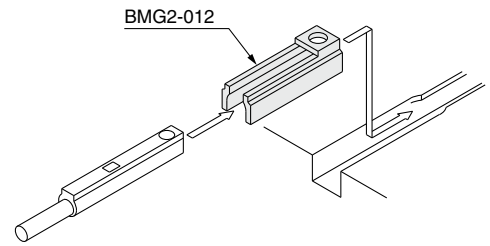

Switch Spacer No.

Cylinder series	Applicable bore size [mm]	
	50	63
MY1HT	BMP1-032	

When attaching an auto switch, first take a switch spacer between your fingers and press it into a switch mounting groove. When doing this, confirm that it is set in the correct mounting orientation, or reattach if necessary. Next, insert an auto switch into the groove and slide it until it is positioned under the switch spacer. After establishing the mounting position, use a watchmaker's flat head screwdriver to tighten the auto switch mounting screw which is included.

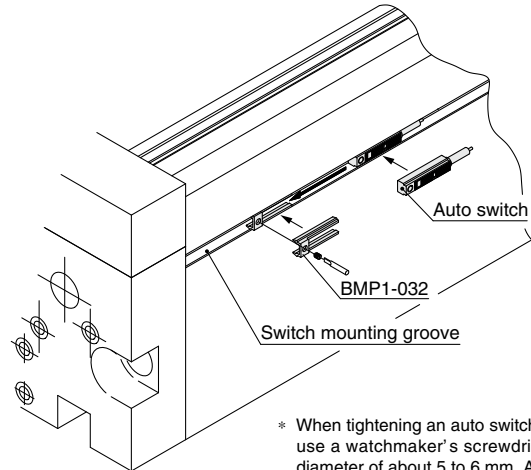
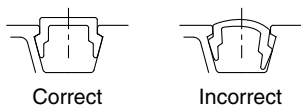

- * When tightening an auto switch mounting screw, use a watchmaker's screwdriver with a handle diameter of about 5 to 6 mm. Also, tighten with a torque of about 0.05 to 0.1 N·m. As a guide, it should be turned about 90° past the point at which tightening can be felt.

Other than the applicable auto switches listed in "How to Order," the following auto switches are mountable. For detailed specifications, refer to the **Web Catalog**.

Type	Model	Electrical entry	Features	Applicable bore size
Solid state auto switch	D-Y69A, Y69B, Y7PV	Grommet (Perpendicular)	—	MY1B ø50 to ø100 MY1M ø25 to ø63 MY1C ø25 to ø63
	D-Y7NWV, Y7PWV, Y7BWV		Diagnostic indication (2-color indicator)	
	D-Y59A, Y59B, Y7P	Grommet (In-line)	—	
	D-Y7NW, Y7PW, Y7BW		Diagnostic indication (2-color indicator)	

- * With pre-wired connector is also available for solid state auto switches. For details, refer to the **Web Catalog**.
- * Normally closed (NC = b contact) solid state auto switches (D-M9□E(V)/Y7G/Y7H) are also available. For details, refer to the **Web Catalog**.

Model Selection

MY1B

MY1M

MY1C

MY1H

MY1HT

Auto Switch Mounting

Made to Order Common Specifications

Specific Product Precautions

Prior to Use

Auto Switch Connections and Examples

Sink Input Specifications

3-wire, NPN

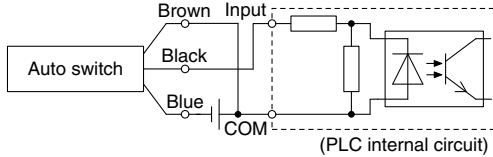

2-wire

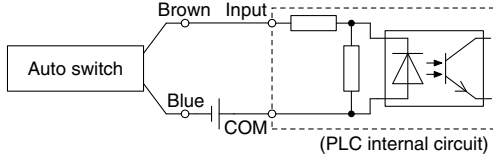

Source Input Specifications

3-wire, PNP

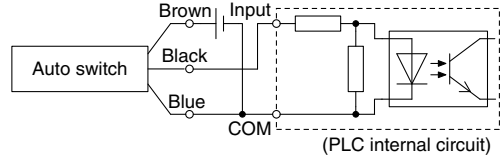

2-wire

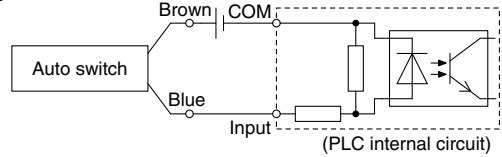

Connect according to the applicable PLC input specifications, as the connection method will vary depending on the PLC input specifications.

Examples of AND (Series) and OR (Parallel) Connections

* When using solid state auto switches, ensure the application is set up so the signals for the first 50 ms are invalid. Depending on the operating environment, the product may not operate properly.

3-wire AND connection for NPN output (Using relays)

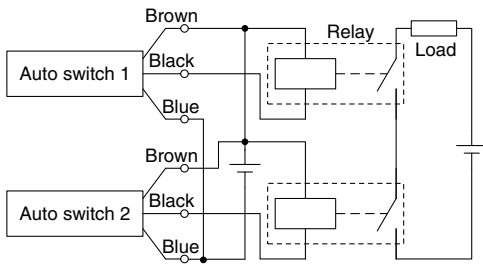

(Performed with auto switches only)

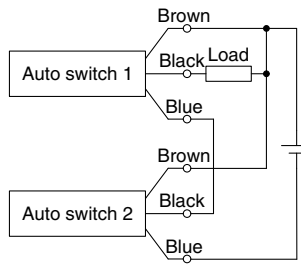

3-wire OR connection for NPN output

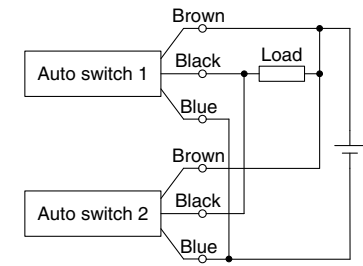

3-wire AND connection for PNP output (Using relays)

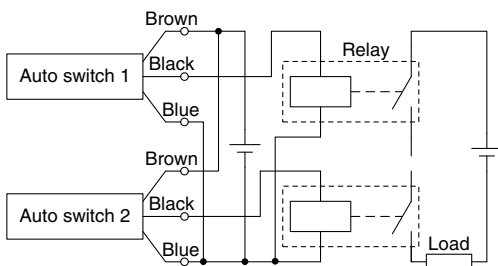

(Performed with auto switches only)

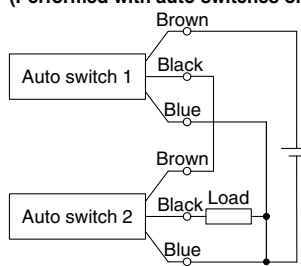

3-wire OR connection for PNP output

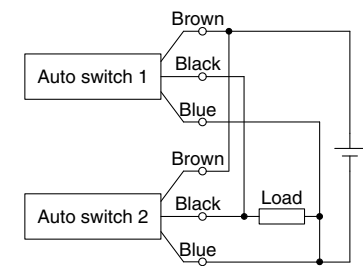

2-wire AND connection

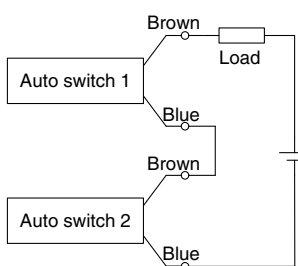

When two auto switches are connected in series, a load may malfunction because the load voltage will decline when in the ON state. The indicator lights will light up when both of the auto switches are in the ON state. Auto switches with a load voltage less than 20 V cannot be used.

$$\begin{aligned} \text{Load voltage at ON} &= \text{Power supply voltage} - \\ &\quad \text{Residual voltage} \times 2 \text{ pcs.} \\ &= 24 \text{ V} - 4 \text{ V} \times 2 \text{ pcs.} \\ &= 16 \text{ V} \end{aligned}$$

Example: Power supply is 24 VDC
Internal voltage drop in auto switch is 4 V.

2-wire OR connection

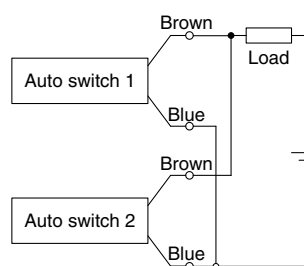

(Solid state)
When two auto switches are connected in parallel, malfunction may occur because the load voltage will increase when in the OFF state.

(Reed)
Because there is no current leakage, the load voltage will not increase when turned OFF. However, depending on the number of auto switches in the ON state, the indicator lights may sometimes grow dim or not light up, due to the dispersion and reduction of the current flowing to the auto switches.

$$\begin{aligned} \text{Load voltage at OFF} &= \text{Leakage current} \times 2 \text{ pcs.} \times \\ &\quad \text{Load impedance} \\ &= 1 \text{ mA} \times 2 \text{ pcs.} \times 3 \text{ k}\Omega \\ &= 6 \text{ V} \end{aligned}$$

Example: Load impedance is 3 k Ω .
Leakage current from auto switch is 1 mA.

MY1 Series

Made to Order Common Specifications

Please contact SMC for detailed specifications, delivery, and prices.



Made to Order Common Specifications

Symbol	Specifications	MY1B (Basic type)	MY1M (Slide bearing guide type)	MY1C (Cam follower guide type)	MY1H (Linear guide type)	MY1HT (High rigidity/Linear guide type)	Page
		ø10, ø16, ø20, ø25, ø32, ø40, ø50, ø63, ø80, ø100	ø16, ø20, ø25, ø32, ø40, ø50, ø63	ø16, ø20, ø25, ø32, ø40, ø50, ø63	ø10, ø16, ø20, ø25, ø32, ø40	ø50, ø63	
-XB22	Shock absorber Soft type RJ series mounted	●*1	●*5	●*5	●		115
-XC56	With knock pin holes			●	●		117
-XC67	Dust seal band NBR lining specifications	●*2	●	●	●*6	●	118
-X168	Helical insert thread specifications	●*3	●	●	●*3	●*7	118
-X1810	Magnet for ø10 solid state auto switch specifications	●*4			●*4		118

- *1 Only applicable to ø10 to ø40
- *2 Only applicable to ø16, ø20, ø50, and ø63
- *3 ø10 is only available as a special product.
- *4 Only applicable to ø10
- *5 Only applicable to ø16 to ø40
- *6 Only applicable to ø16 and ø20
- *7 Produced upon receipt of order.

Model Selection

MY1B

MY1M

MY1C

MY1H

MY1HT

Auto Switch Mounting

Made to Order Common Specifications

Specific Product Precautions



Symbol
-XB22

1 Shock Absorber Soft Type RJ Series Mounted

The standard cylinder has been equipped with shock absorber soft type RJ series type to enable soft stopping at the stroke end. Two different shock absorbers are available in accordance with the operating conditions.

Applicable Series

Description	Model	Bearing type	Applicable bore size
Mechanically jointed rodless cylinder	MY1B	Basic	ø10 to ø40
	MY1M	Slide bearing guide	ø16 to ø40
	MY1C	Cam follower guide	ø16 to ø40
	MY1H	Single-axis linear guide	ø10 to ø40

How to Order

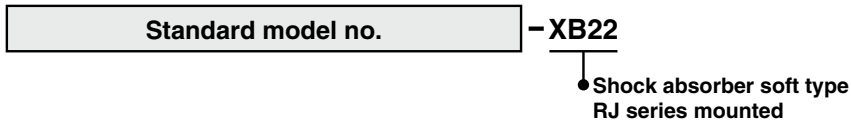

How to Order a Stroke Adjustment Unit for MY Itself



Specifications

Absorbed energy	For the impact mass graph, refer to page 116.
Specifications other than the above and dimensions	Same as the standard type

Cylinders

Model	Type	Stroke adjustment unit	Bore size					
			ø10	ø16	ø20	ø25	ø32	ø40
MY1B	-XB22	L	RJ0805	RJ0604*1	RJ0806H	RJ1007H	RJ1412H	
		H			RJ1007H	RJ1412H	—	—
	Standard	L	RB0805	RB0806	RB1007	RB1412		
		H	RB0805	RB1007	RB1412	RB2015		
MY1M MY1C	-XB22	L	RJ0805	RJ0604*1	RJ0806H	RJ1007H	RJ1412H	
		H			RJ1007H	RJ1412H	—	—
	Standard	L	RB0805	RB0806	RB1007	RB1412		
		H	RB0805	RB1007	RB1412	RB2015		
MY1H	-XB22	L	RJ0805	RJ0604*1	RJ0806H	RJ1007H	RJ1412H	
		H			RJ1007H	RJ1412H	—	—
	Standard	L	RB0805	RB0806	RB1007	RB1412		
		H	RB0805	RB1007	RB1412	RB2015		

*1 The MY1B16 standard model uses an RJ0604.

- * Refer to the **Web Catalog** for the details of the shock absorber RJ and RB series.
- * The shock absorber service life is different from that of each cylinder. Refer to the "Specific Product Precautions" of the RJ series for the replacement period.

Symbol
-XB22

1 Shock Absorber Soft Type RJ Series Mounted

Impact Mass Graph (Shock Absorber Performance Line Graph)

* Values in the impact mass graph are at room temperature (20 to 25°C).

Ensure that the impact mass and the collision speed are within the absorbed energy graphs below.
Refer to each cylinder selection calculation for load factors and guide load factors.

Type of collision

Horizontally-applied impact

Air cylinder impact (horizontal/upward)

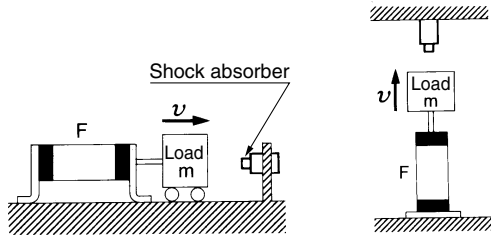

Air cylinder impact (downward)

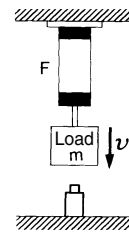

RJ0805 Absorbed Energy

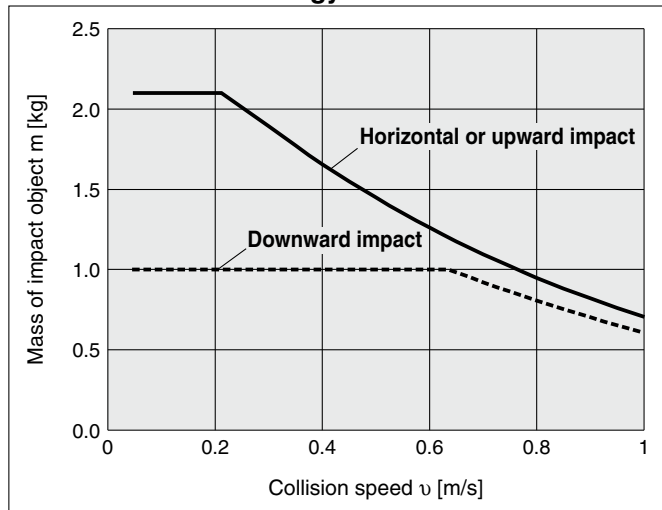

RJ0806H Absorbed Energy

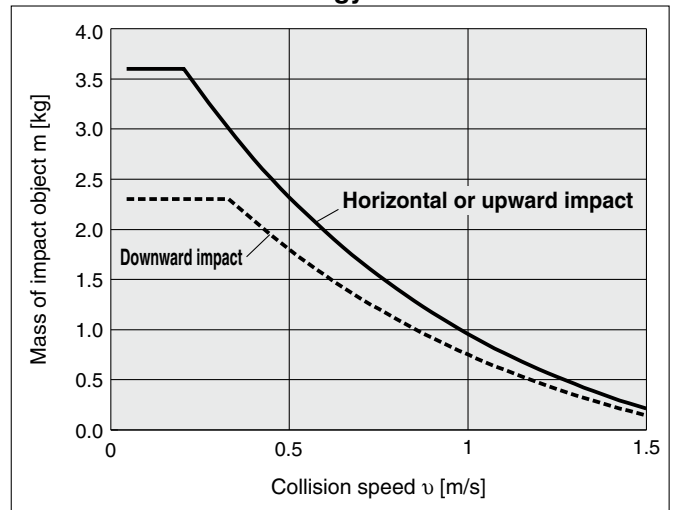

RJ1007H Absorbed Energy

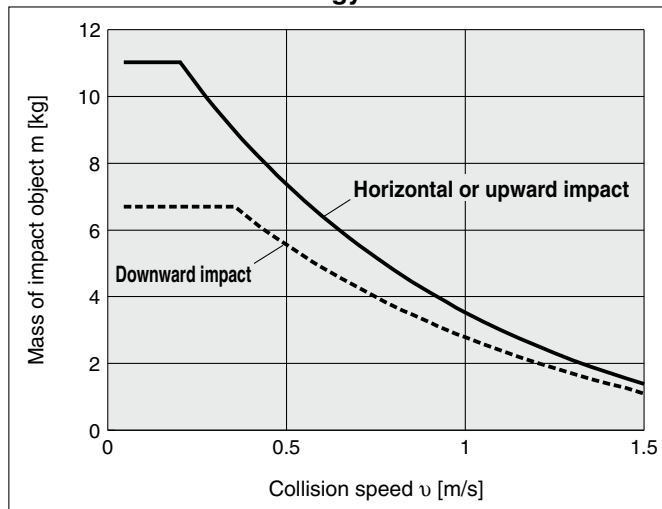

RJ1412H Absorbed Energy

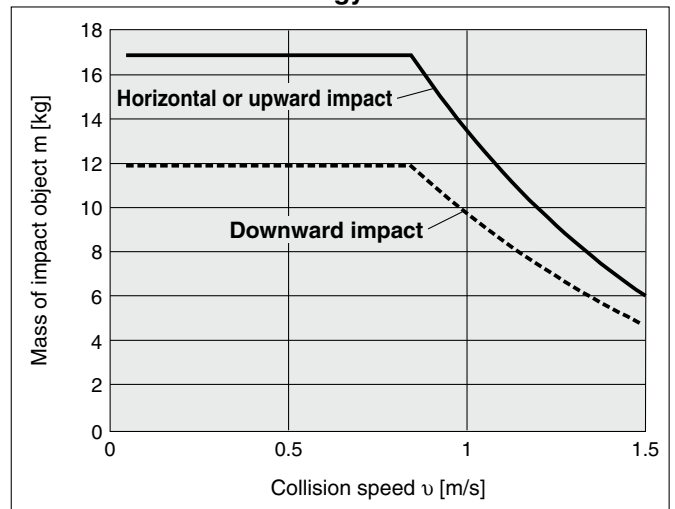

* Be sure to read "Handling Precautions for SMC Products" (M-E03-3) and "Shock Absorber Soft Type RJ Series" (Web Catalog) before use.

Model Selection

MY1B

MY1M

MY1C

MY1H

MY1HT

Auto Switch Mounting

Made to Order Common Specifications

Specific Product Precautions

MY1 Series

Symbol
-XC56

2 With Knock Pin Holes

Cylinder with knock positioning pin hole

Applicable Series

Description	Model	Action
Mechanically jointed rodless cylinder	MY1C	Cam follower guide
	MY1H	Linear guide

How to Order

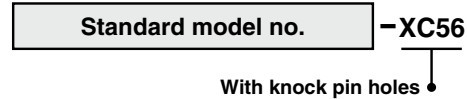

Specifications: Same as the standard type

Dimensions (Dimensions other than specified below are the same as the standard type.)

MY1C series

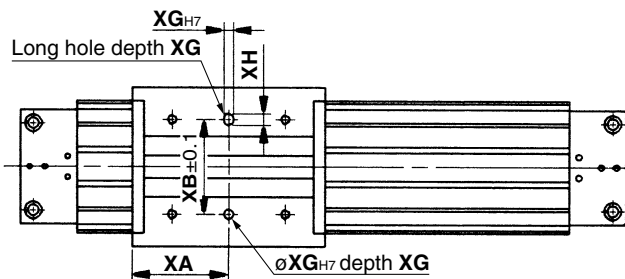

Mounting surface of a workpiece for the slide table

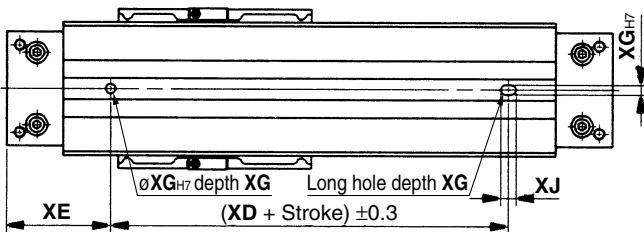

Mounting surface of cylinder tube

Bore size [mm]	XA	XB	XD	XE	XG	XH	XJ
16	40	40	80	40	4	5	9
20	50	40	100	50	4	5	9
25	51	50	110	55	5	6	10
32	66	60	140	70	6	7	11
40	81	80	180	80	6	7	11
50	100	90	230	85	8	9	13
63	115	110	280	90	10	10	15

MY1H(-Z) series

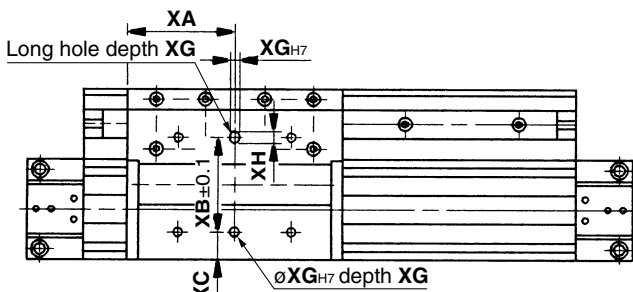

Mounting surface of a workpiece for the slide table

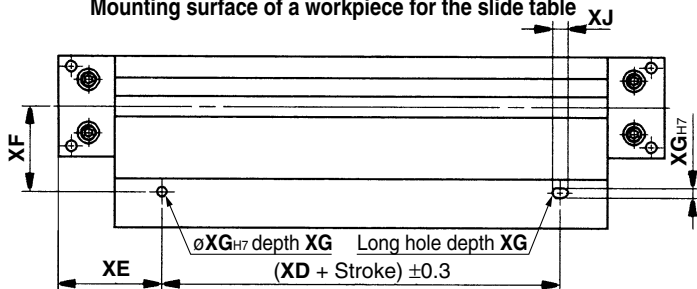

Mounting surface of cylinder tube

Bore size [mm]	XA	XB	XC	XD	XE
10	25	33	3.5	70	20
16	40	40	7.5	80	40
20	50	40	14.5	100	50
25	57	50	14.5	110	55
32	70	60	15	140	70
40	85	80	20.5	180	80

Bore size [mm]	XF	XG	XH	XJ
10	21.5	3	4	5
16	30	4	5	7
20	39	4	5	7
25	45	5	6	8
32	60	6	7	9
40	60.5	6	7	9

3 Dust Seal Band NBR Lining Specifications

Symbol
-XC67

The standard vinyl chloride lining specification is changed to NBR lining.
Oil resistance and peeling resistance are improved.

* Please consult with SMC for specific details on oil resistance.

MY1 **B** **Bore size** - **Stroke** **Stroke adjustment unit** - **Auto switch** **Suffix** -XC67

Type/Bore size		10	16	20	25	32	40	50	63	80	100
B	Basic	●	●	●	●	●	●	●	●	●	●
M	Slide bearing guide	●	●	●	●	●	●	●	●	●	●
C	Cam follower guide	●	●	●	●	●	●	●	●	●	●
H	Linear guide	●	●	●	●	●	●	●	●	●	●
HT	High rigidity/Linear guide							●	●		

Example) MY1B40G-300L-Z73-XC67

For ordering dust seal band (NBR lining) only

MY **Bore size** - 16 **B** **N** **Stroke**

Dust seal band
NBR lining

Dust seal band
Hexagon socket head set
screw thread treatment

Nil	Black zinc chromated
W	Nickel plating

Example) MY25-16BNW-300

For details, refer to "Dust seal band" in the construction of each series.

Applicable Series

Description	Model	Type
Mechanically jointed rodless cylinder	MY1B	Basic
	MY1M	Slide bearing guide
	MY1C	Cam follower guide
	MY1H	Linear guide
	MY1HT	High rigidity/Linear guide

4 Helical Insert Thread Specifications

Symbol
-X168

Helical insert thread is used for the slide table mounting thread, the thread size is the same as the standard model.

MY1 **B** **Bore size** - **Stroke** **(Z)***1 - **Auto switch** **Suffix** -X168

Type/Bore size		10	16	20	25	32	40	50	63	80	100
B	Basic	●	●	●	●	●	●	●	●	●	●
M	Slide bearing guide	●	●	●	●	●	●	●	●	●	●
C	Cam follower guide	●	●	●	●	●	●	●	●	●	●
H	Linear guide	●	●	●	●	●	●	●	●	●	●
HT	High rigidity/Linear guide							●	●		

(●) is available as special orders.

Example) MY1B20G-300L-M9BW-X168

*1 Please specify "Z" for the MY1B25 to 40 and the MY1H25 to 40.

5 Magnet for ø10 Solid State Auto Switch Specifications

Symbol
-X1810

By incorporating the use of the magnet for solid state auto switches, switch operation stability can be achieved.

* If you are using, or planning to use, the cylinder in combination with a solid state auto switch, but are currently only ordering the cylinder, please add the "-X1810" suffix to the end of the product number.

MY1 **B** 10G - **Stroke** **Stroke adjustment unit** -X1810

● Magnet for ø10 solid state auto switch specifications

Type	
B	Basic
H	Linear guide

* If an auto switch is included in the product number, the "-X1810" suffix does not need to be added to the end of the product number.

Example) MY1B10G-300H-M9BL