

# Escapements

# MIW/MIS Series

ø8, ø12, ø20, ø25, ø32

RoHS

## How to Order

**Double finger type** MIW 12 [ ] - 12 D 1 A S - M9BW [ ] - [ ]

**Single finger type** MIS 32 [ ] - 50 D 1 A S - M9BW [ ] - [ ]

**Finger options**

Nil: Basic type (Standard type)

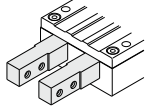

1: Tapped on upper and lower faces

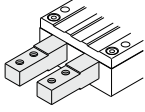

2: Tapped on all faces (5 surfaces including end surface)

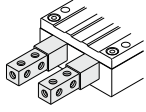

**Cylinder bore**

8	8 mm
12	12 mm
20	20 mm
25	25 mm
32	32 mm

**Port thread type**

Symbol	Type	Bore size
Nil	M thread	ø8, ø12 ø20, ø25
	Rc	
TN	NPT	ø32
TF	G	

**Stroke**

\* Refer to the next page for standard stroke table.

**Scraper**

Nil	No
S	Yes

**Stroke adjuster**

Nil	No
A	Yes

**Number of auto switches**

Nil	2 pcs.
S	1 pc.

**Type of auto switch**

Nil	Without auto switch (built-in magnet)
-----	---------------------------------------

\* Refer to the table below for auto switch part numbers.

**Finger options**

Nil: Basic type (Standard type)

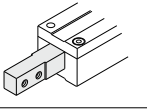

1: Tapped on upper and lower faces

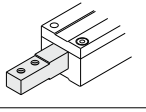

2: Tapped on all faces (5 surfaces including end surface)

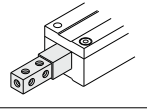

### Applicable auto switches/Refer to pages 941 to 1067 for detailed specifications of auto switches.

Type	Special function	Electrical entry	Indicator light	Wiring (output)	Load voltage		Auto switch models		Lead wire length (m)				Pre-wired connector	Applicable load	
					DC	AC	Perpendicular	In-line	0.5 (Nil)	1 (M)	3 (L)	5 (Z)			
Solid state auto switch	Diagnostic indication (2-color display)	Grommet	Yes	3-wire (NPN)	24 V	—	M9NV	M9N	●	●	●	○	○	IC circuit	
				3-wire (PNP)			M9PV	M9P	●	●	●	○	○		
				2-wire			M9BV	M9B	●	●	●	○	○		
				3-wire (NPN)			M9NVV	M9NV	●	●	●	○	○		IC circuit
				3-wire (PNP)			M9PVV	M9PV	●	●	●	○	○		IC circuit
				2-wire			M9BVV	M9B	●	●	●	○	○		—
	Water resistant (2-color indicator)	Grommet	Yes	3-wire (NPN)	24 V	—	M9NAV**	M9NA**	○	○	●	○	○	IC circuit	
				3-wire (PNP)			M9PAV**	M9PA**	○	○	●	○	○		
				2-wire			M9BAV**	M9BA**	○	○	●	○	○		
				2-wire			M9BAV**	M9BA**	○	○	●	○	○		

\*\* Water resistant type auto switches can be mounted on the above models, but in such case SMC cannot guarantee water resistance.

\* Lead wire length symbols: 0.5 m ..... Nil (Example) M9NW  
 1 m ..... M (Example) M9NW  
 3 m ..... L (Example) M9NWL  
 5 m ..... Z (Example) M9NWZ

\* Solid state auto switches marked with "○" are produced upon receipt of order.

\* Refer to pages 1014 and 1015 for the details of auto switches with a pre-wired connector.

\* Auto switches are shipped together (not assembled).

### Specifications



Series	<b>MIW</b> (Double finger) <b>MIS</b> (Single finger)
Fluid	Air
Operating pressure	0.2 to 0.7 MPa
Ambient temperature and fluid temperature	-10 to 60°C (No freezing)
Lubrication	Non-lube
Action	Double acting
Auto switch (optional) <sup>Note)</sup>	Solid state auto switch (3-wire, 2-wire)
Stroke tolerance	$^{+1}_0$ mm

### Option

Finger options	Standard, Tapped on upper and lower faces, Tapped on all faces (5 surfaces including end surface)
Stroke adjuster (Rear end stroke only)	<b>MI□8</b> : Arrangement range 4 mm
	<b>MI□12</b> : Arrangement range 6 mm
	<b>MI□20</b> : Arrangement range 12 mm
	<b>MI□25</b> : Arrangement range 15 mm
	<b>MI□32</b> : Arrangement range 20 mm
Scraper	Can be mounted on standard products

### Theoretical Output

Unit: N

Bore size (mm)	Rod size (mm)	Operating direction	Piston area (mm <sup>2</sup> )	Operating pressure MPa					
				0.2	0.3	0.4	0.5	0.6	0.7
8	4	OUT	50	10	15	20	26	31	36
		IN	38	7	11	15	19	23	26
12	6	OUT	113	23	34	45	57	68	79
		IN	85	17	26	34	43	51	60
20	10	OUT	314	63	94	126	157	188	220
		IN	236	47	71	94	118	142	165
25	10	OUT	491	98	147	196	245	295	344
		IN	412	82	124	165	206	247	288
32	12	OUT	804	161	241	322	402	482	563
		IN	691	138	207	276	346	415	484

### Standard Stroke

#### Double finger type/MIW (mm)

Bore size	Stroke
8	8 mm
12	12 mm
20	20 mm
25	25 mm
32	32 mm

\* For MIW, same stroke as bore size

#### Single finger type/MIS (mm)

Bore size	Stroke
8	10, 20 mm
12	10, 20, 30 mm
20	10, 20, 30 mm
25	30, 50 mm
32	30, 50 mm

**Made to Order**  
**Made to Order:**  
**Individual Specifications**  
 (For details, refer to page 633.)

Symbol	Specifications
-X4	Heat resistant (-10 to 100°C)
-X5	Fluororubber seal
-X63	Fluorine grease
-X79	Grease for food

### Weight

Model	Model	Stroke (mm)	Weight (g)	Increase by stroke adjuster (g)	Increase by scraper (g)
MIW	MIW8-8D	8	110	6	3
	MIW12-12D	12	240	10	5
	MIW20-20D	20	650	30	10
	MIW25-25D	25	1550	30	20
	MIW32-32D	32	2650	100	35
MIS	MIS8-10D	10	62	3	2
	MIS8-20D	20	80		
	MIS12-10D	10	130	5	3
	MIS12-20D	20	160		
	MIS12-30D	30	190		
	MIS20-10D	10	300	15	5
	MIS20-20D	20	355		
	MIS20-30D	30	410		
	MIS25-30D	30	800	15	10
	MIS25-50D	50	1000		
	MIS32-30D	30	1350	50	18
MIS32-50D	50	1650			

RSQ

RSQ

RS2H

RSH

MIW/MIS

D-□

X-□

# MIW/MIS Series

## Construction/Double Finger Type (MIW)

ø8

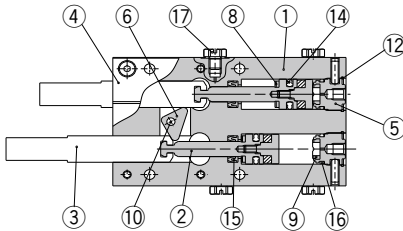

ø12, ø20

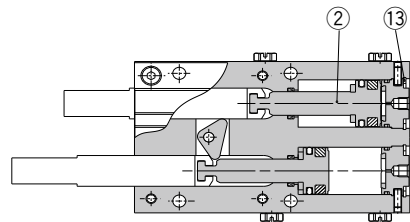

ø25, ø32

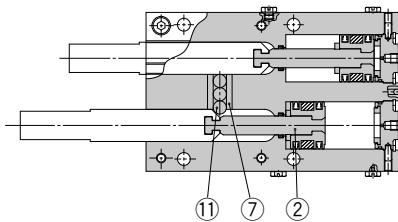

Option

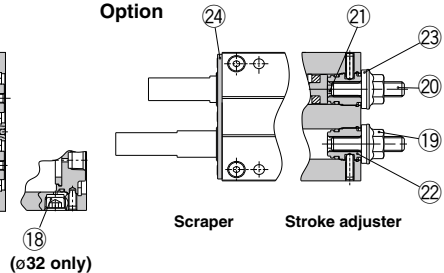

### Component parts

No.	Description	Material	Note
1	Body	Aluminum alloy	Hard anodized
2	Piston assembly	Carbon steel	Heat treatment/Special treatment
3	Finger	Carbon steel	Heat treatment/Special treatment
4	Cover	Aluminum alloy	Hard anodized
5	Cap (W)	Aluminum alloy	White anodized
6	Cam	Stainless steel	Heat treatment (MIW8 to 20)
7	Roller holder	Stainless steel	Heat treatment (MIW25, 32)
8	Bumper	Urethane rubber	
9	Head bumper	Urethane rubber	
10	Needle roller	High carbon chromium bearing steel	(MIW8 to 20)

No.	Description	Material	Note
11	Cylinder roller	Carbon steel	(MIW25, 32)
12	Clip	Carbon steel	(MIW8)
13	R shape retaining ring	Carbon steel	(MIW12 to 32)
14	Piston seal	NBR	
15	Rod seal	NBR	
16	Gasket	NBR	
17	Plug		(MIW8 ... M-3P) (MIW12 to 25 ... M-5P)
18	Hexagon socket taper plug		(MIW32 ... Rc1/8)

### Option: adjuster

No.	Description	Material	Note
19	Hexagon nut with flange	Carbon steel	Nickel plated
20	Adjustment bolt	Carbon steel	Nickel plated
21	Adjustment bumper	Urethane rubber	
22	Adjustment cap	Aluminum alloy	White anodized
23	Die thread		

### Option: scraper

No.	Description	Material	Note
24	Scraper	Stainless steel + NBR	

### Replacement parts

Model	Description	Finger			Seal kit	Scraper assembly	Grease pack
		Standard	Tapped on upper and lower faces	Tapped on all faces			
MIW8-8D		MI-A0801-8	MI-A0802-8	MI-A0803-8	MIW8-PS	MIW-A0804	MH-G01 (contents quantity 30 g)
MIW12-12D		MI-A1201-12	MI-A1202-12	MI-A1203-12	MIW12-PS	MIW-A1204	
MIW20-20D		MI-A2001-20	MI-A2002-20	MI-A2003-20	MIW20-PS	MIW-A2004	
MIW25-25D		MI-A2501-25	MI-A2502-25	MI-A2503-25	MIW25-PS	MIW-A2504	
MIW32-32D		MI-A3201-32	MI-A3202-32	MI-A3203-32	MIW32-PS	MIW-A3204	
Main parts No.		③ (1 pc.)			⑭, ⑮, ⑯	⑳	

**Construction/Single Finger Type (MIS)**

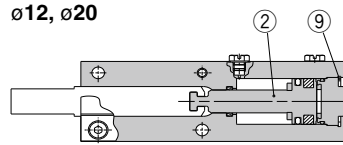
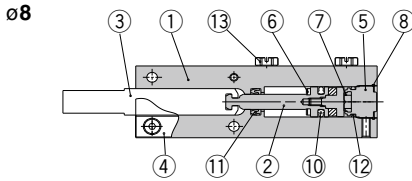

ø25, ø32

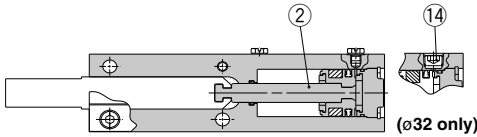

**Option**

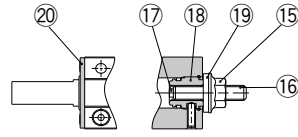

Scraper

Stroke adjuster

**Component parts**

No.	Description	Material	Note
1	Body	Aluminum alloy	Hard anodized
2	Piston assembly		
3	Finger	Carbon steel	Heat treatment/Special treatment
4	Cover	Aluminum alloy	Hard anodized
5	Cap (S)	Aluminum alloy	White anodized
6	Bumper	Urethane rubber	
7	Head bumper	Urethane rubber	
8	Clip	Carbon steel	(MIS8)
9	R shape retaining ring	Carbon steel	(MIS12 to 32)

No.	Description	Material	Note
10	Piston seal	NBR	
11	Rod seal	NBR	
12	Gasket	NBR	
13	Plug		(MIS8 ... M-3P) (MIS12 to 25 ... M-5P)
14	Hexagon socket taper plug		(MIS32 ... Rc1/8)

**Option: adjuster**

No.	Description	Material	Note
15	Hexagon nut with flange	Carbon steel	Nickel plated
16	Adjustment bolt	Carbon steel	Nickel plated
17	Adjustment bumper	Urethane rubber	
18	Adjustment cap	Aluminum alloy	White anodized
19	Die thread		

**Option: scraper**

No.	Description	Material	Note
20	Scraper	Stainless steel + NBR	

**Replacement parts**

Model	Description	Finger			Seal kit	Scraper assembly	Grease pack
		Standard	Tapped on upper and lower faces	Tapped on all faces			
MIS8-10D	MI-A0801-10	MI-A0802-10	MI-A0803-10		MIS8-PS	MIS-A0804	MH-G01 (contents quantity 30 g)
MIS8-20D	MI-A0801-20	MI-A0802-20	MI-A0803-20				
MIS12-10D	MI-A1201-10	MI-A1202-10	MI-A1203-10		MIS12-PS	MIS-A1204	
MIS12-20D	MI-A1201-20	MI-A1202-20	MI-A1203-20				
MIS12-30D	MI-A1201-30	MI-A1202-30	MI-A1203-30		MIS20-PS	MIS-A2004	
MIS20-10D	MI-A2001-10	MI-A2002-10	MI-A2003-10				
MIS20-20D	MI-A2001-20	MI-A2002-20	MI-A2003-20		MIS25-PS	MIS-A2504	
MIS20-30D	MI-A2001-30	MI-A2002-30	MI-A2003-30				
MIS25-30D	MI-A2501-30	MI-A2502-30	MI-A2503-30		MIS32-PS	MIS-A3204	
MIS25-50D	MI-A2501-50	MI-A2502-50	MI-A2503-50				
MIS32-30D	MI-A3201-30	MI-A3202-30	MI-A3203-30		MIS32-PS	MIS-A3204	
MIS32-50D	MI-A3201-50	MI-A3202-50	MI-A3203-50				
<b>Main parts No.</b>		③ (1 pc.)			⑩, ⑪, ⑫	⑳	

RSQ

RSG

RS2H

RSH

MIW  
MIS

D-□

-X□

## Dimensions/Double Finger Type

### MIW□-□D

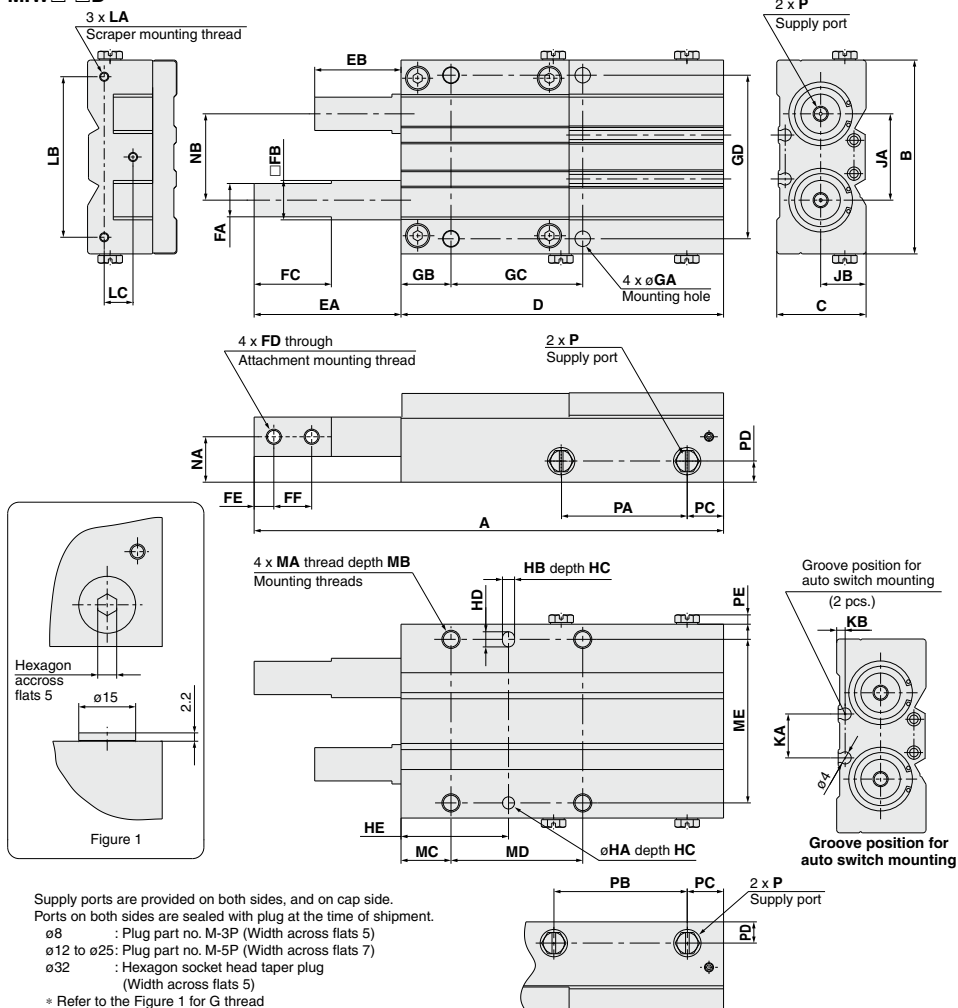

Model	A	B	C	D	EA	EB	FA	FB	FC	FD	FE	FF	FG	GA	GB	GC	GD
MIW8-8	83	34	16	57	26	18	6 <sup>±0.1</sup>	7h9 <sup>±0.036</sup>	15	M3 x 0.5	4	7	6 (Effective depth 2.5)	2.6	9	22	28
MIW12-12	111	44	21	76	35	23	8 <sup>±0.1</sup>	10h9 <sup>±0.036</sup>	19	M3 x 0.5	4.5	9.5	6 (Effective depth 3)	3.3	12.5	34	37
MIW20-20	155	64	29.5	106.5	48.5	28.5	11 <sup>±0.1</sup>	13h9 <sup>±0.043</sup>	25.5	M5 x 0.8	6.5	12.5	10 (Effective depth 4)	5.1	16.5	43.5	54
MIW25-25	200	84	40	134	66	41	15 <sup>±0.1</sup>	17h9 <sup>±0.043</sup>	37	M6 x 1	10	17	15 (Effective depth 7)	6.8	20	58	71
MIW32-32	256	95	47	169	87	55	19.5 <sup>±0.1</sup>	21h9 <sup>±0.052</sup>	51	M8 x 1.25	12.5	22	17 (Effective depth 8.5)	8.6	24.5	73	80

Model	HA, HB	HC	HD	HE	JA	JB	KA	KB	LA	LB
MIW8-8	2H9 <sup>±0.025</sup>	2	3	15	14.5	7.5	20.3	1.6	M2 x 0.4	28.4
MIW12-12	2.5H9 <sup>±0.025</sup>	4	3.5	25	19	11	7.6	2.2	M2.6 x 0.45	37
MIW20-20	4H9 <sup>±0.030</sup>	5	5	35.5	28.5	15	14.5	2.8	M3 x 0.5	53
MIW25-25	5H9 <sup>±0.030</sup>	5	7	40	35.5	20	24.5	3	M3 x 0.5	70
MIW32-32	6H9 <sup>±0.030</sup>	6	8	50	44.5	25	24.1	2.5	M4 x 0.7	81

**Finger options**

**Tapped on upper and lower faces**

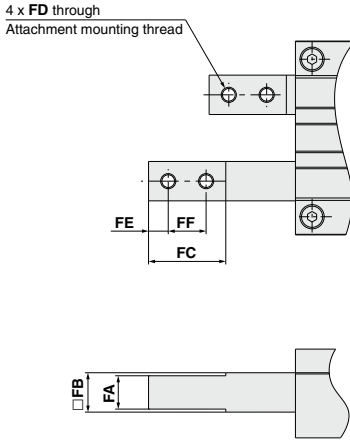

**Tapped on all faces**

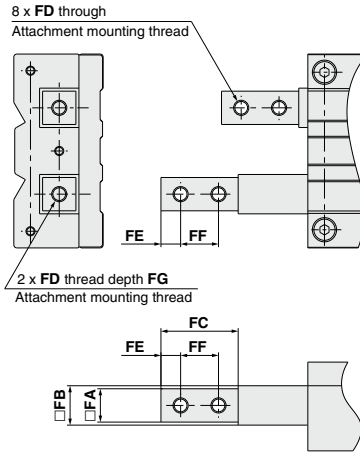

**Stroke adjuster**

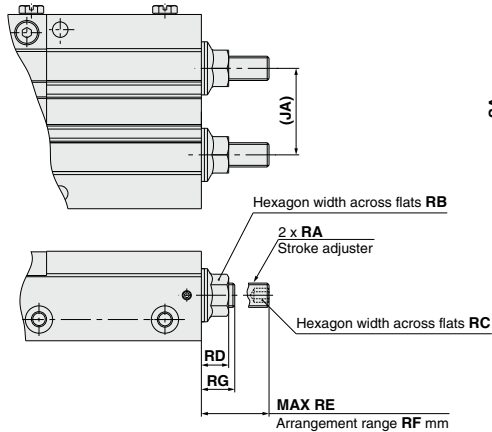

**Scraper**

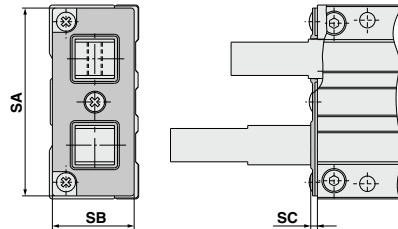

Note) Observe the specified adjustment range when adjusting with a stroke adjuster.

Model	LC	MA	MB	MC	MD	ME	NA	NB	P	PA	PB	PC	PD	PE	RA	RB	RC	RD
MIW8-8	4.5	M3 x 0.5	6	9	22	28	7.5	14.5	M3 x 0.5	22.5	24	8	4.5	2.2	M4 x 0.7	7	2	5.7
MIW12-12	7.5	M4 x 0.7	7	12.5	34	37	11	19	M5 x 0.8	25	27	10	6	2.8	M5 x 0.8	8	2.5	6
MIW20-20	9.5	M6 x 1	10	16.5	43.5	54	15	28.5	M5 x 0.8	41.5	44	12	7	2.7	M8 x 1	12	4	9
MIW25-25	12	M8 x 1.25	12	20	58	71	20	35.5	M5 x 0.8	50	55	14	8.5	2.7	M8 x 1	12	4	9
MIW32-32	16.5	M10 x 1.5	15	24.5	73	80	25	44.5	Rc1/8	69.5	75.5	14.5	11	—	M12 x 1.25	17	6	12.4

Model	RE	RF	RG	SA	SB	SC
MIW8-8	12.5	4	8.5	33	14.5	1.4
MIW12-12	14	6	8	43	18.5	1.8
MIW20-20	22.5	12	10.5	62	27	2.2
MIW25-25	26	15	11	81	35	2.8
MIW32-32	33	20	13	93	42	3.4

RSQ

RSG

RS2H

RSH

MIW  
MIS

D-□

-X□

# MIW/MIS Series

## Dimensions/Single Finger Type

MIS□-□D

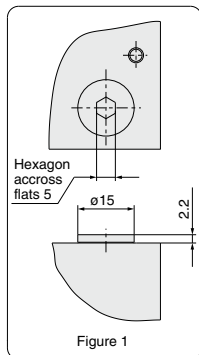
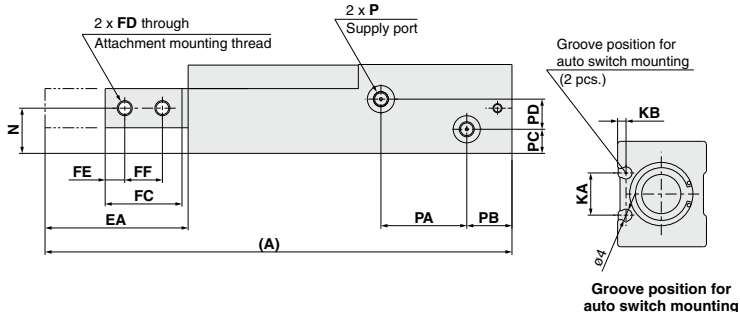
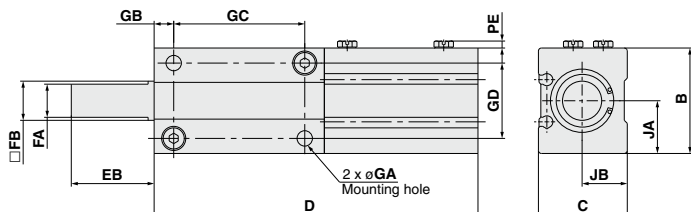
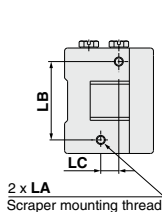
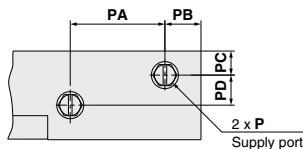
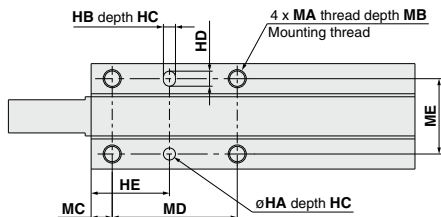

Figure 1



Supply ports are provided on both sides.  
 A port on a side is sealed with plug at the time of shipment.  
 ø8 : Plug part no. M-3P (Width across flats 5)  
 ø12 to ø25: Plug part no. M-5P (Width across flats 7)  
 ø32 : Hexagon socket head taper plug  
 (Width across flats 5)  
 \* Refer to the Figure 1 for G thread

Model	A	B	C	D	EA	EB	FA	FB	FC	FD	FE	FF	FG	GA	GB	GC	GD	HA, HB
MIS8-10	87	19	16	59	28	18	6 <sup>0</sup> <sub>0.1</sub>	7h9 <sup>0</sup> <sub>0.06</sub>	15	M3 x 0.5	4	7	6 (Effective depth 2.5)	2.6	4	20	13	2H9 <sup>0</sup> <sub>0.025</sub>
MIS8-20	117			79	38											30		
MIS12-10	105	26	21	72	33	23	8 <sup>0</sup> <sub>0.1</sub>	10h9 <sup>0</sup> <sub>0.06</sub>	19	M3 x 0.5	4.5	9.5	6 (Effective depth 3)	3.3	5	28	18	2.5H9 <sup>0</sup> <sub>0.025</sub>
MIS12-20	135			92	43											38		
MIS12-30	165			112	53											48		
MIS20-10	125	35	29.5	86.5	38.5	28.5	11 <sup>0</sup> <sub>0.1</sub>	13h9 <sup>0</sup> <sub>0.043</sub>	25.5	M5 x 0.8	6.5	12.5	10 (Effective depth 4)	5.1	7	32	25	4H9 <sup>0</sup> <sub>0.020</sub>
MIS20-20	155			106.5	48.5											42		
MIS20-30	185			126.5	58.5											52		
MIS25-30	215	41	40	144	71	41	15 <sup>0</sup> <sub>0.1</sub>	17h9 <sup>0</sup> <sub>0.043</sub>	37	M6 x 1	10	17	15 (Effective depth 7)	6.8	10	55	28	5H9 <sup>0</sup> <sub>0.020</sub>
MIS25-50	275			184	91											75		
MIS32-30	250	50	47	165	85	55	19.5 <sup>0</sup> <sub>0.1</sub>	21h9 <sup>0</sup> <sub>0.052</sub>	51	M8 x 1.25	12.5	22	17 (Effective depth 8.5)	8.6	12	64	34	6H9 <sup>0</sup> <sub>0.020</sub>
MIS32-50	310			205	105											84		

**Finger options**  
Tapped on upper and lower faces

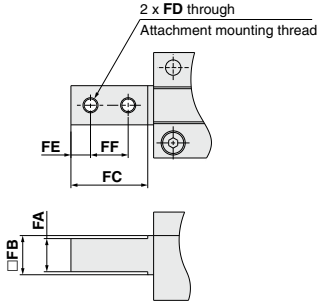

**Tapped on all faces**

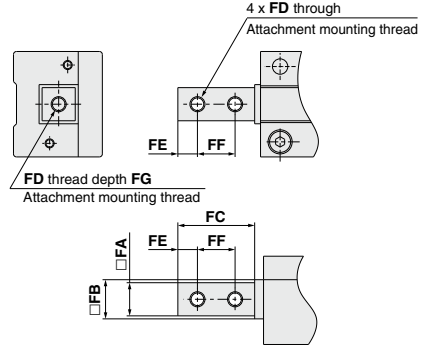

**With adjuster**

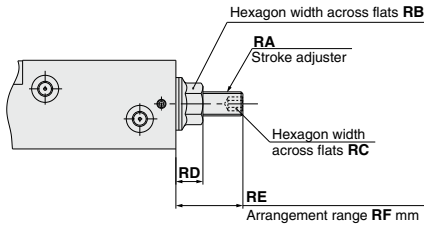

**With scraper**

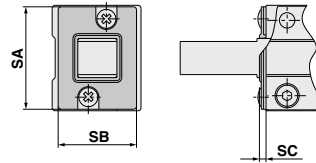

Note) Observe the specified adjustment range when adjusting with a stroke adjuster.

Model	HC	HD	HE	JA	JB	KA	KB	LA	LB	LC	MA	MB	MC	MD	ME	N	P	PA	PB	PC
MIS8-10	2	3	14	9.5	7.5	6.2	1.6	M2 x 0.4	14	3	M3 x 0.5	5	4	20	13	7.5	M3 x 0.5	19	8	4.5
MIS8-20														30				29		
MIS12-10														28				19		
MIS12-20	4	3.5	17.5	13	11	11.6	2.2	M2.6 x 0.45	19	4	M4 x 0.7	7	5	38	18	11	M5 x 0.8	29	10	6
MIS12-30														48				39		
MIS20-10														32				20.5		
MIS20-20	5	5	26	17.5	15	14	2.8	M3 x 0.5	26	6	M6 x 1	10	7	42	25	15	M5 x 0.8	30.5	12	8
MIS20-30														52				40.5		
MIS25-30	5	7	32	20.5	20	11	3	M3 x 0.5	32	10	M8 x 1.25	14	10	55	28	20	M5 x 0.8	47	14	12
MIS25-50														75				67		
MIS32-30	6	8	40	25	25	20.4	2.5	M4 x 0.7	39	12	M10 x 1.5	15	12	64	34	25	Rc1/8	47	14.5	11
MIS32-50														84				67		

Model	PD	PE	RA	RB	RC	RD	RE	RF	SA	SB	SC
MIS8-10	6	2.2	M4 x 0.7	7	2	5.7	12.5	4	18.6	14	1.4
MIS8-20											
MIS12-10											
MIS12-20	7	3	M5 x 0.8	8	2.5	6	14	6	24	18	1.8
MIS12-30											
MIS20-10											
MIS20-20	10	3	M8 x 1	12	4	9	22.5	12	34	26	2.2
MIS20-30											
MIS25-30	14	2.7	M8 x 1	12	4	9	26	15	40	36	2.8
MIS25-50											
MIS32-30	27	—	M12 x 1.25	17	6	12.4	33	20	49	41	3.4
MIS32-50											

RSQ

RSG

RS2H

RSH

MIW  
MIS

D-□

-X□



# MIW/MIS Series Auto Switch Mounting

## Auto Switch Mounting

When mounting an auto switch, insert the auto switch in the switch mounting groove on the escapement from the direction as below figure. Having set the mounting position, tighten the attached auto switch mounting screws with a flat head watchmaker's screwdriver.

- \* When adjusting the auto switch mounting screws, use a watchmaker's screwdriver with a handle 5 to 6 mm in diameter. (This is to prevent fracture due to an excessive torque.)  
The guideline of the tightening torque is 0.1 to 0.15 N·m.

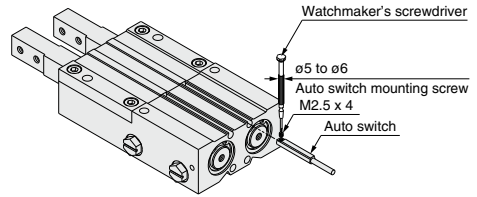

## Proper mounting position for stroke end detection

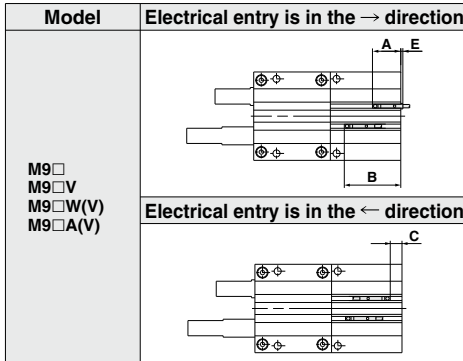

## Auto Switch Operating Range

MIW	(mm)				
Auto switch model	ø8	ø12	ø20	ø25	ø32
D-M9□(V) D-M9□W(V) D-M9□A(V)	3	2.5	4	5.5	7

MIS	(mm)				
Auto switch model	ø8	ø12	ø20	ø25	ø32
D-M9□(V) D-M9□W(V) D-M9□A(V)	3	3.5	4.5	5.5	7

Note) The operating ranges are provided as guidelines including hysteresis and are not guaranteed values (with ±30% variations). Hysteresis may fluctuate due to the operating environments.

Model	Proper mounting position		Model	Proper mounting position		Model	Proper mounting position	
	D-M9□ D-M9□W D-M9□A	D-M9□V D-M9□WV D-M9□AV		D-M9□ D-M9□W D-M9□A	D-M9□V D-M9□WV D-M9□AV		D-M9□ D-M9□W D-M9□A	D-M9□V D-M9□WV D-M9□AV
MIW8-8D	A	16.5	MIS12-30D	A	18.5	MIS25-30D	A	7.5
	B	25		B	49		B	38
	C	4.5		C	6.5		C	21
	D	—		D	—		D	—
	E	6   4		E	3.5   1.5		E	—   —
MIS8-10D	A	16.5	MIW20-20D	A	20.5	MIS25-50D	A	7.5
	B	27		B	41		B	38
	C	4.5		C	8.5		C	21
	D	—		D	—		D	—
	E	6   4		E	4   2		E	—   —
MIS8-20D	A	16.5	MIS20-10D	A	20.5	MIW32-32D	A	8.5
	B	37		B	31		B	41
	C	4.5		C	8.5		C	29
	D	—		D	—		D	—
	E	6   4		E	4   2		E	—   —
MIW12-12D	A	18.5	MIS20-20D	A	20.5	MIS32-30D	A	8.5
	B	31		B	51		B	39
	C	6.5		C	8.5		C	29
	D	—		D	—		D	—
	E	3.5   1.5		E	4   2		E	—   —
MIS12-10D	A	18.5	MIS20-30D	A	20.5	MIS32-50D	A	8.5
	B	29		B	61		B	59
	C	6.5		C	8.5		C	29
	D	—		D	—		D	—
	E	3.5   1.5		E	4   2		E	—   —
MIS12-20D	A	18.5	MIW25-25D	A	7.5			
	B	39		B	33			
	C	6.5		C	21			
	D	—		D	—			
	E	3.5   1.5		E	—   —			

Note) Adjust the auto switch after confirming the operating conditions in the actual setting.



## 1 Heat Resistant (-10 to 100°C)

Symbol

**-X4**

Change seal material and greases, so that it can be used at an ambient temperature range from -10 °C to up to 100 °C.

### How to Order

MIW  - **X4**

● Heat resistant

Note) Magnets are built-in, but the applicable ambient temperature is from -10 °C to 60 °C when auto switches are used.

### Specifications

Ambient temperature range	-10°C to 100°C
Seal material	Fluororubber
Grease	Heat resistant grease (GR-F)
Bore size (mm)	8, 12, 20, 25, 32

\* Dimensions other than the above is the same as the standard type.

### Warning

#### Precautions

Be aware that smoking cigarettes etc. after your hands have come into contact with the grease used in this cylinder can create a gas that is hazardous to humans.

## 2 Fluororubber Seal

Symbol

**-X5**

### How to Order

MIW  - **X5**

● Fluororubber seal

Note) Since the same magnets as for the standard type are built-in, contact SMC for the product adaptability to the operating environment before handling.

### Specifications

Seal material	Fluororubber
Bore size (mm)	8, 12, 20, 25, 32

\* Dimensions other than the above is the same as the standard type.

## 3 Fluorine Grease

Symbol

**-X63**

### How to Order

MIW  - **X63**

● Fluorine grease

### Warning

#### Precautions

Be aware that smoking cigarettes etc. after your hands have come into contact with the grease used in this cylinder can create a gas that is hazardous to humans.

### Specifications

Grease	PTFE grease (GR-F)
Bore size (mm)	8, 12, 20, 25, 32

\* Dimensions other than the above is the same as the standard type.

RSQ

RSG

RS2H

RSH

MIW

MIS

D-□

-X□



## 4 Grease for Food Processing Equipment

Symbol  
**-X79**

Food grade grease (certified by NSF-H1)/Fluorine grease are used as lubricant.

### How to Order

MIW MIS Standard model no. —X79

● Grease for food processing equipment

### Specifications

Grease	Grease for food processing equipment/ Fluorine grease
Bore size (mm)	8, 12, 20, 25, 32

\* Specifications and external dimensions other than above are the same as standard type.

### Warning

#### Precautions

Be aware that smoking cigarettes etc. after your hands have come into contact with the grease used in this cylinder can create a gas that is hazardous to humans.

<Not installable>

Food zone.....An environment where food which will be sold as merchandize, directly touches the cylinder's components.

Splash zone.....An environment where food which will not be sold as merchandize, directly touches the cylinder's components.

<Installable>

Non-food zone.....An environment where there is no contact with food.

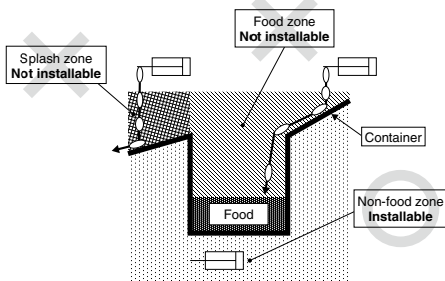

Note 1) Avoid using this product in the food zone. (Refer to the figure above.)

Note 2) Operate without lubrication from a pneumatic system lubricator.

Note 3) Use the following grease pack for the maintenance work.

GR-H-010 (Grease: 10 g)

Note 4) Please contact SMC for details on the maintenance intervals for this cylinder, which differ from those of the standard cylinder.

RSQ

RSG

RS2H

RSH

MIW  
MIS

D-□

-X□