

Process Pump

Automatically Operated Type (Internal Switching Type)

Air Operated Type (External Switching Type)

PA3000 Series

RoHS

How to Order



PA 3 1 1 0 - 03 -

Material of body wetted areas

Symbol	Material of body wetted areas
1	ADC12 (Aluminum)
2	SCS14 (Stainless steel)

Diaphragm material

Symbol	Diaphragm material	Applicable actuation	
		Automatically operated	Air operated
1	PTFE	●	●
2	NBR	●	—

Actuation

Symbol	Actuation
0	Automatically operated
3	Air operated

Option

Symbol	Option	Applicable actuation	
		Automatically operated	Air operated
NII	Body only	●	●
N	With silencer*	●	—

* For AIR EXH: AN20-□02

(□: Either Nil or N is entered as a thread symbol.)

Port size

Symbol	Port size
03	3/8"

Thread type

Symbol	Type
Nil	Rc
N	NPT
F	G
T	NPTF

Symbol

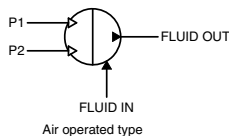
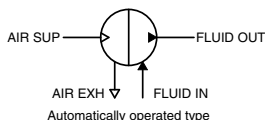

Specifications

Model	PA3110	PA3120	PA3210	PA3220	PA3113	PA3213	
Actuation	Automatically operated				Air operated		
Port size	Main fluid suction/discharge port Rc, NPT, G, NPTF 3/8" Female thread						
	Pilot air supply/exhaust port Rc, NPT, G, NPTF 1/4" Female thread						
Material	Body wetted areas		ADC12		SCS14		
	Diaphragm		PTFE, NBR		PTFE, NBR		
Check valve		PTFE, PFA				PTFE	
Discharge rate	1 to 20 L/min				0.1 to 12 L/min		
Average discharge pressure	0 to 0.6 MPa				0 to 0.4 MPa		
Pilot air pressure	0.2 to 0.7 MPa				0.1 to 0.5 MPa		
Air consumption	Max. 200 L/min (ANR) or less				Max. 150 L/min (ANR) or less		
Suction⁽¹⁾ lifting range	Dry 1 m (Interior of pump dry)						
	Wet Up to 6 m (liquid inside pump)						
Noise	80 dB (A) or less (Option: with silencer, AN20)				72 dB (A) or less (excluding the noise from the quick exhaust and solenoid valve)		
Withstand pressure	1.05 MPa				0.75 MPa		
Diaphragm life	100 million times	50 million times	100 million times	50 million times	50 million times		
Fluid temperature	0 to 60°C (No freezing)						
Ambient temperature	0 to 60°C (No freezing)						
Maximum viscosity	1000 mPa·s						
Recommended operating cycle	—				1 to 7 Hz (0.2 to 1 Hz also possible depending on conditions) ^(Note 2)		
Pilot air solenoid valve recommended Cv factor ^(Note 3)	—				0.20		
Weight	1.7 kg		2.2 kg		1.7 kg	2.2 kg	
Mounting orientation	Horizontal (with mounting foot at bottom)						
Packaging	General environment						

* Each of the values above are for normal temperatures and when the transferred fluid is fresh water.

* Refer to page 558 for maintenance parts.

* For related products, refer to pages 622 and 623.

Note 1) With cycles at 2 Hz or more

Note 2) After initial suction of liquid operating at 1 to 7 Hz, it can be used with operation at lower cycles.

Since a large quantity of liquid will be pumped out, use a suitable throttle in the discharge port if problems occur.

Note 3) With a low number of operating cycles, even a valve with a small Cv factor can be operated.



Made to order specifications
(For details, refer to pages 563 and 564)

Products complying with ATEX
With air operated reset port ^(Note)
With operating cycle counting port ^(Note)

Note) For automatically operated type only.

Process Pump

Automatically Operated Type (Internal Switching Type)

Air Operated Type (External Switching Type)

PA5000 Series

RoHS

PA

PA(P)

PAX

PB

PAF

PA□

PB

How to Order

PA5000



PA 5 1 1 0 - 04 - □

Material of body wetted areas

Symbol	Material of body wetted areas
1	ADC12 (Aluminum)
2	SCS14 (Stainless steel)

Diaphragm material

Symbol	Diaphragm material	Applicable actuation	
		Automatically operated	Air operated
1	PTFE	●	●
2	NBR	●	—

Actuation

Symbol	Actuation
0	Automatically operated
3	Air operated

Option

Symbol	Option	Applicable actuation	
		Automatically operated	Air operated
Nil	Body only	●	●
N	With silencer*	●	—

* For AIR EXH: AN20-□02

(□: Either Nil or N is entered as a thread symbol.)

Port size

Symbol	Port size
04	1/2"
06	3/4"

Thread type

Symbol	Type
Nil	Rc
N	NPT
F	G
T	NPTF

Symbol

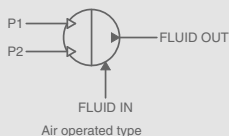
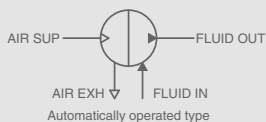

A new type of PA5000 with a polypropylene body is now available. [Click here for details.](#)

Model	PA5110	PA5120	PA5210	PA5220	PA5113	PA5213
Actuation	Automatically operated				Air operated	
Port size	Main fluid suction/discharge port Rc, NPT, G, NPTF 1/2", 3/4" Female thread		Pilot air supply/exhaust port Rc, NPT, G, NPTF 1/4" Female thread			
Material	Body wetted areas ADC12		SCS14		ADC12	SCS14
Check valve	PTFE	NBR	PTFE	NBR	PTFE	
Discharge rate	5 to 45 L/min				1 to 24 L/min	
Average discharge pressure	0 to 0.6 MPa				0 to 0.4 MPa	
Pilot air pressure	0.2 to 0.7 MPa				0.1 to 0.5 MPa	
Air consumption	Max. 300 L/min (ANR) or less				Max. 250 L/min (ANR) or less	
Suction lifting range	Up to 2 m (Interior of pump dry)				Up to 0.5 m (Interior of pump dry)	
	Up to 6 m (Liquid inside pump)					
Noise	78 dB (A) or less (Option: with silencer, AN 20)				72 dB (A) or less (excluding the noise from the quick exhaust and solenoid valve)	
Withstand pressure	1.05 MPa				0.75 MPa	
Diaphragm life	50 million times					
Operating fluid temperature	0 to 60°C (No freezing)					
Ambient temperature	0 to 60°C (No freezing)					
Maximum viscosity	1000 mPa·s					
Recommended operating cycle	—				1 to 7 Hz (0.2 to 1 Hz also possible depending on conditions) ^{Note 2)}	
Pilot air solenoid valve recommended Cv factor	—				0.45	
Weight	3.5 kg		6.5 kg		3.5 kg	6.5 kg
Mounting orientation	Horizontal (with mounting foot at bottom)					
Packaging	General environment					

Made to Order

Made to order specifications (For details, refer to pages 563 and 564)

Products complying with ATEX
With air operated reset port ^{Note)}
With operating cycle counting port ^{Note)}

Note) For automatically operated type only.

* Each of the values above are for normal temperatures and when the transferred fluid is fresh water.

* Refer to page 558 for maintenance parts.

* For related products, refer to pages 622 and 623.

Note 1) With cycles at 2 Hz or more

Note 2) After initial suction of liquid operating at 1 to 7 Hz, it can be used with operation at lower cycles.

Since a large quantity of liquid will be pumped out, use a suitable throttle in the discharge port if problems occur.

Note 3) With a low number of operating cycles, even a valve with a small Cv factor can be operated.

A new type of PA5000 with a polypropylene body is now available. [Click here for details.](#)

Performance Curve: Automatically Operated Type

PA3□□0 Flow Rate Characteristics

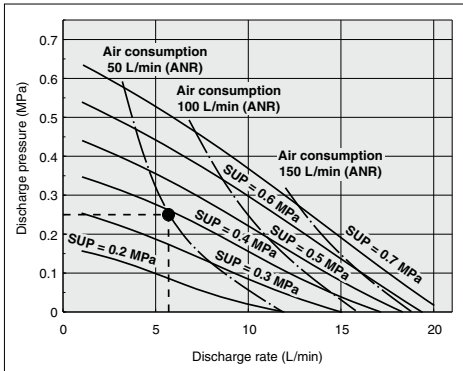

PA5□□0 Flow Rate Characteristics

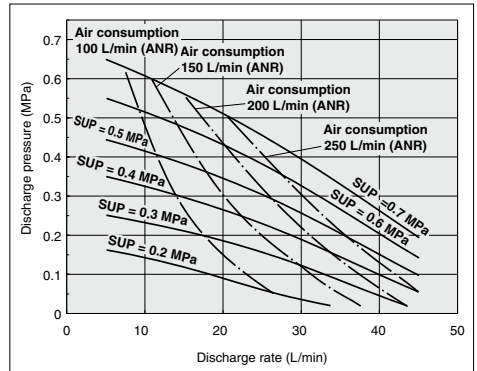

Selection from Flow Rate Characteristic Graph (PA3□□0)

Required specifications example:

Find the pilot air pressure and pilot air consumption for a discharge rate of 6 L/min and a discharge pressure of 0.25 MPa. <The transfer fluid is fresh water (viscosity 1 mPa·s, specific gravity 1.0).>

* If the total lifting height is required instead of the discharge pressure, a discharge pressure of 0.1 MPa corresponds to a total lift of 10 m.

Selection procedures:

1. First mark the intersection point for a discharge rate of 6 L/min and a discharge pressure of 0.25 MPa.
2. Find the pilot air pressure for the marked point. In this case, the point is between the discharge curves (solid lines) for SUP = 0.3 MPa and SUP = 0.4 MPa, and based on the proportional relationship to these lines, the pilot air pressure for this point is approximately 0.38 MPa.
3. Next find the air consumption rate. Since the marked point is below the curve for 50 L/min (ANR), the maximum rate will be about 50 L/min (ANR).

⚠ Caution

1. These flow rate characteristics are for fresh water (viscosity 1 mPa·s, specific gravity 1.0).
2. The discharge rate differs greatly depending on properties (viscosity, specific gravity) of the fluid being transferred and operating conditions (lifting range, transfer distance), etc.
3. Use 0.75 kW per 100 L/min of air consumption as a guide for the relationship of the air consumption to the compressor.

Viscosity Characteristics (Flow rate correction for viscous fluids)

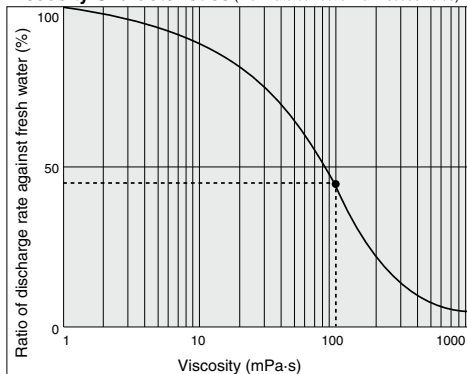

Selection from Viscosity Characteristic Graph

Required specifications example:

Find the pilot air pressure and pilot air consumption for a discharge rate of 2.7 L/min, and a viscosity of 100 mPa·s.

Selection procedures:

1. First find the ratio of the discharge rate for fresh water when viscosity is 100 mPa·s from the graph below. It is determined to be 45%.
2. Next, in the required specification example, the viscosity is 100 mPa·s and the discharge rate is 2.7 L/min. Since this is equivalent to 45% of the discharge rate for fresh water, $2.7 \text{ L/min} \div 0.45 = 6 \text{ L/min}$, indicating that a discharge rate of 6 L/min is required for fresh water.
3. Finally, find the pilot air pressure and pilot air consumption based on selection from the flow characteristic graphs.

⚠ Caution

Viscosities up to 1000 mPa·s can be used.
Dynamic viscosity $v = \text{Viscosity } \mu / \text{Density } \rho$.

$$v = \frac{\mu}{\rho}$$

$$v(10^{-3} \text{ m}^2/\text{s}) = \mu(\text{mPa}\cdot\text{s})/\rho(\text{kg}/\text{m}^3)$$

A new type of PA5000 with a polypropylene body is now available. [Click here for details.](#)

Performance Curve: Air Operated Type

PA3□13 Flow Rate Characteristics

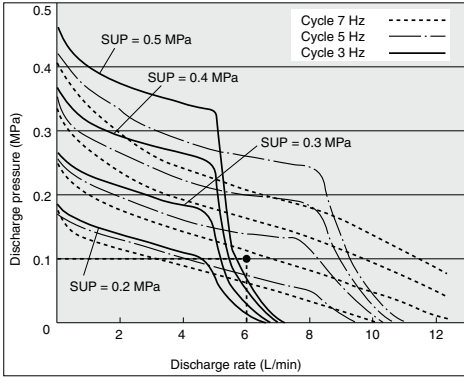

PA5□13 Flow Rate Characteristics

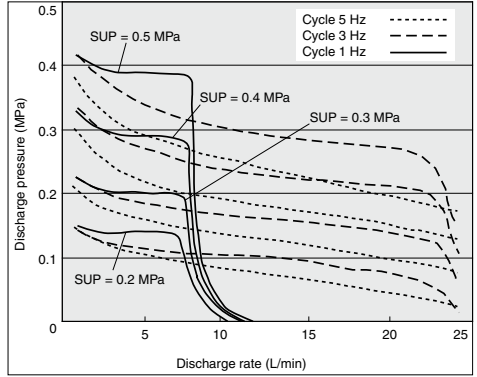

- PA
- PA(P)
- PAX
- PB
- PAF
- PA□
- PB

PA3□13 Air Consumption

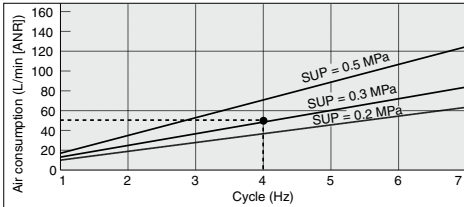

PA5□13 Air Consumption

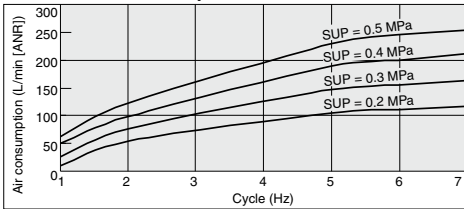

Viscosity Characteristics (Flow rate correction for viscous fluids)

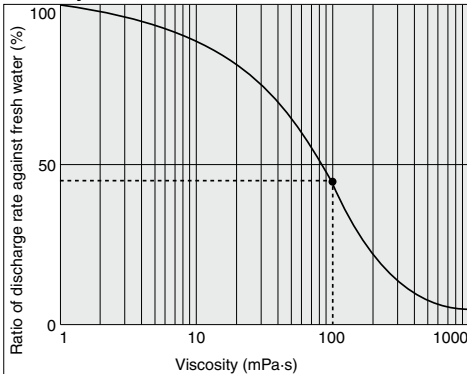

Selection from Flow Rate Characteristic Graph (PA3□13)

Required specification example: Find the pilot air pressure and pilot air consumption for a discharge rate of 6 L/min. <The transfer fluid is fresh water (viscosity 1 mPa-s, specific gravity 1.0).>
 Note 1) If the total lifting height is required instead of the discharge pressure, a discharge pressure of 0.1 MPa corresponds to a total lift of 10 m.

Selection procedures:

1. First mark the intersection point for a discharge rate of 6 L/min and a discharge pressure of 0.1 MPa.
2. Find the pilot air pressure for the marked point. In this case, the point is between the discharge curves (solid lines) for SUP = 0.2 MPa and SUP = 0.3 MPa, and based on the proportional relationship to these lines, the pilot air pressure for this point is approximately 0.25 MPa.

⚠ Caution

1. These flow rate characteristics are for fresh water (viscosity 1 mPa-s, specific gravity 1.0).
2. The discharge rate differs greatly depending on properties (viscosity, specific gravity) of the fluid being transferred and operating conditions (density, lifting range, transfer distance).

Calculating Air Consumption (PA3□13)

Find the air consumption for operation with a 4 Hz switching cycle and pilot air pressure of 0.3 MPa from the air consumption graph.

Selection procedures:

1. Look up from the 4 Hz switching cycle to find the intersection with SUP = 0.3 MPa.
2. From the point just found, draw a line to the Y-axis to find the air consumption. The result is approximately 50 L/min (ANR).

Selection from Viscosity Characteristic Graph

Required specification example: Find the pilot air pressure and pilot air consumption for a discharge rate of 2.7 L/min, and a viscosity of 100 mPa-s.

Selection procedures:

1. First find the ratio of the discharge rate for fresh water when viscosity is 100 mPa-s from the graph below. It is determined to be 45%.
2. Next, in the required specification example, the viscosity is 100m Pa-s and the discharge rate is 2.7 L/min. Since this is equivalent to 45% of the discharge rate for fresh water, $2.7 \text{ L/min} \div 0.45 = 6 \text{ L/min}$, indicating that a discharge rate of 6 L/min is required for fresh water.
3. Finally, find the pilot air pressure and pilot air consumption based on selection from the flow characteristic graphs.

⚠ Caution

Viscosities up to 1000 mPa-s can be used.
 Dynamic viscosity $v = \text{Viscosity } \mu / \text{Density } \rho$.

$$v = \frac{\mu}{\rho}$$

$$v(10^{-3} \text{ m}^2/\text{s}) = \mu(\text{mPa}\cdot\text{s})/\rho(\text{kg}/\text{m}^3)$$

A new type of PA5000 with a polypropylene body is now available. [Click here for details.](#)

Working Principle

Automatically Operated Type

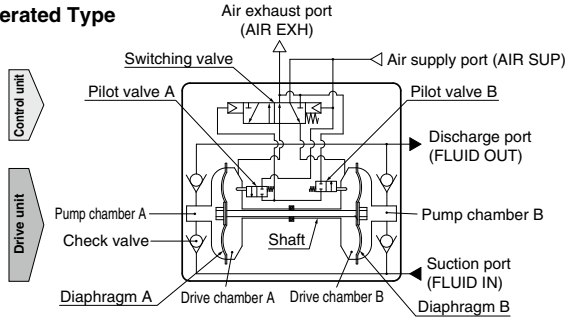

Control unit

1. When air is supplied, it passes through the switching valve and enters drive chamber B.
2. Diaphragm B moves to the right, and at the same time diaphragm A also moves to the right pushing pilot valve A.
3. When pilot valve A is pushed, air acts upon the switching valve, drive chamber A switches to a supply state, and the air which was in drive chamber B is exhausted to the outside.
4. When air enters drive chamber A, diaphragm B moves to the left pushing pilot valve B.
5. When pilot valve B is pushed, the air which was acting upon the switching valve is exhausted, and drive chamber B once again switches to a supply state. A continuous reciprocal motion is generated by this repetition.

Drive unit

1. When air enters drive chamber B, the fluid in pump chamber B is forced out, and at the same time fluid is sucked into pump chamber A.
2. When the diaphragm moves in the opposite direction, the fluid in pump chamber A is forced out, and fluid is sucked into pump chamber B.
3. Continuous suction and discharge is performed by the reciprocal motion of the diaphragm.

Air Operated Type

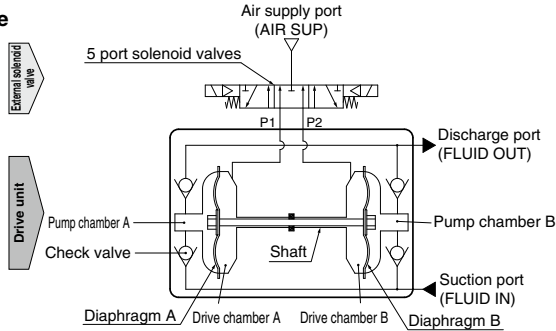

1. When air is supplied to P1 port, it enters drive chamber A.
2. Diaphragm A moves to the left, and at the same time diaphragm B also moves to the left.
3. The fluid in pump chamber A is forced out to the discharge port, and the fluid is sucked into pump chamber B from the suction port.
4. If air is supplied to the P2 port, the opposite will occur. Continuous suction and discharge of fluid is performed by repeating this process with the control of an external solenoid valve (5 port valve).

Maintenance Parts

- ⚠ While it is not possible to disassemble this product without voiding the warranty, if disassembly is to be carried out anyway due to necessity, be sure to follow the maintenance procedures.
- When carrying out this work, wear appropriate protective equipment.

PA3000/5000 Series

Description	PA3000 series			PA5000 series		
	PA3□10	PA3□20	PA3□13	PA5□10	PA5□20	PA5□13
Diaphragm kit	KT-PA3-31	KT-PA3-32	KT-PA3-31	KT-PA5-31	KT-PA5-32	KT-PA5-31
Check valve kit	KT-PA3-36			KT-PA5-36		
Switching valve assembly kit	KT-PA3-37□ (Note)			—		
Switching valve parts kit	—			KT-PA5-37		
Pilot valve kit	KT-PA5-38			KT-PA5-38		
Manual cap assembly kit	KT-PA3-45			KT-PA5-45		

Note) One of Nil, N, F or T is entered as a thread symbol.

A new type of PA5000 with a polypropylene body is now available. [Click here for details.](#)

Piping and Operation: Automatically Operated Type

Piping diagram

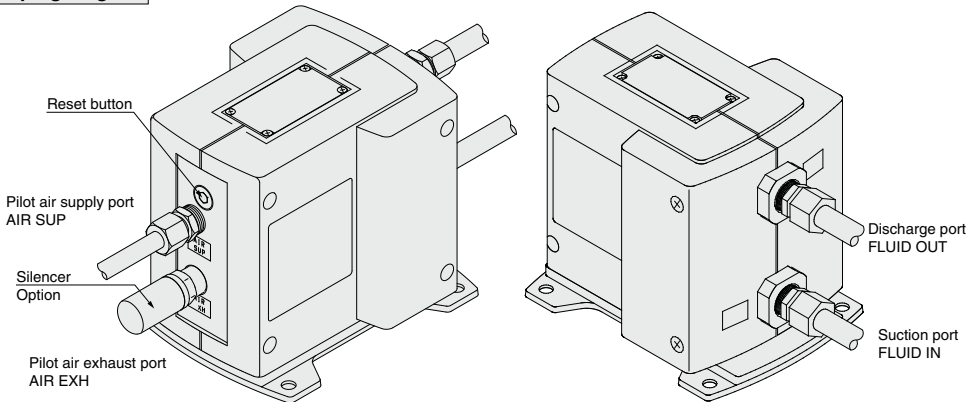

⚠ Caution

Mounting posture of the pump is set with the mounting bracket facing downward. Air to be supplied to the air supply port <AIR SUP> should be cleaned and filtered through AF filter, etc. Air with foreign matter or drainage etc. will have negative effects on the built-in directional control valve and will lead to malfunction. When air needs additional purification, use a filter (AF series), and a mist separator (AM series) together.

Maintain the proper tightening torque for fittings and mounting bolts, etc. Looseness can cause problems such as fluid and air leaks, while over tightening can cause damage to threads and parts, etc.

Operation

<Starting and Stopping> Refer to circuit example (1)

1. Connect air piping to the air supply port <AIR SUP> and connect piping for the fluid to be transferred to the suction port <FLUID IN> and the discharge port <FLUID OUT>.
 2. Using a regulator, set the pilot air pressure within the range of 0.2 to 0.7 MPa. Then, the pump operates when power is applied to the 3 port solenoid valve of the air supply port <AIR SUP>, the sound of exhaust begins from the air exhaust port <AIR EXH> and fluid flows from the suction port <FLUID IN> to the discharge port <FLUID OUT>.
- At this time, the throttle on the discharge side is in an open state. The pump performs suction with its own power even without priming. (Dry state suction lifting range: max. 1 m) To restrict exhaust noise, attach a silencer (AN20-02: option) to the air exhaust port <AIR EXH>.
3. To stop the pump, exhaust the air pressure being supplied to the pump by the 3 port solenoid valve of the air supply port <AIR SUP>. The pump will also stop if the throttle on the discharge side is closed.

<Discharge Flow Rate Adjustment>

1. To adjust the flow rate from the discharge port <FLUID OUT>, use the throttle connected to the discharge side. Refer to circuit example (1). Note that this product cannot be used as a fixed quantity liquid dispense pump.
2. When operating with a discharge flow rate below the specification range, provide a by-pass circuit from the discharge side to the suction side to ensure the minimum flow rate inside the process pump. With a discharge flow rate below the minimum flow rate, the process pump may stop due to unstable operation. Refer to circuit example (2). (Minimum flow rates: PA3000 1 L/min, PA5000 5 L/min)

<Reset Button>

When the pump stops during operation, press the reset button. This makes it possible to restore operation in case the switching valve becomes clogged due to foreign matter in the supply air.

Circuit example (1)

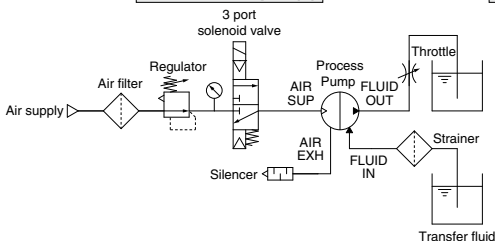

Circuit example (2)

For related products, refer to pages 622 and 623.

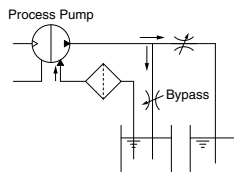

A new type of PA5000 with a polypropylene body is now available. [Click here for details.](#)

Piping and Operation: Air Operated Type

Piping diagram

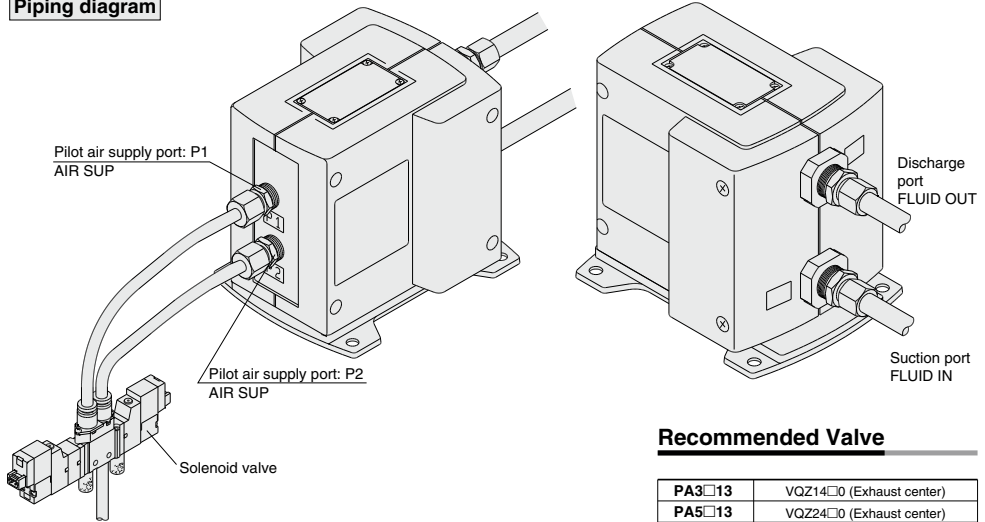

⚠ Caution

Maintain the proper tightening torque for fittings and mounting bolts, etc. Looseness can cause problems such as fluid and air leaks, while over tightening can cause damage to threads and parts, etc.

Operation

<Starting and Stopping> Refer to circuit example

1. Connect air piping ^{Note 1)} to the pilot air supply port <P1>, <P2> and connect piping for the fluid to be transferred to the suction port <FLUID IN> and the discharge port <FLUID OUT>.
2. Using a regulator, set the pilot air pressure within the range of 0.1 to 0.5 MPa. Then, the pump operates when power is applied to the solenoid valve ^{Note 2)} of the pilot air supply port and fluid flows from the suction port <FLUID IN> to the discharge port <FLUID OUT>. At this time, the throttle on the discharge side is in an open state. The pump performs suction with its own power even without priming. (Dry state suction lifting range: PA3 1 m, PA5 up to 0.5 m ^{Note 3)}) To restrict exhaust noise, attach a silencer to the solenoid valve air exhaust port.
3. To stop the pump, exhaust the air pressure being supplied to the pump with the solenoid valve of the air supply port.

Note 1) When used for highly permeable fluids, the solenoid valve may malfunction due to the gas contained in the exhaust. Implement measures to keep the exhaust from going to the solenoid valve side.

Note 2) For the solenoid valve, use an exhaust center 5 port valve, or a combination of residual exhaust 3 port valve and a pump drive 4 port valve. If air in the drive chamber is not released when the pump is stopped, the diaphragm will be subjected to pressure and its life will be shortened.

Note 3) When the pump is dry, operate the solenoid valve at a switching cycle of 1 to 7 Hz. If operated outside of this range, the suction lifting height may not reach the prescribed value.

<Discharge Flow Rate Adjustment>

1. The flow rate from the discharge port <FLUID OUT> can be adjusted easily by changing the switching cycle of the solenoid valve on the air supply port.

Circuit example (1)

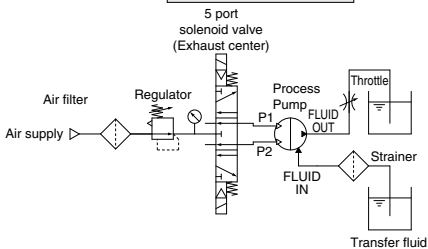

Circuit example (2)

For related products, refer to pages 622 and 623.

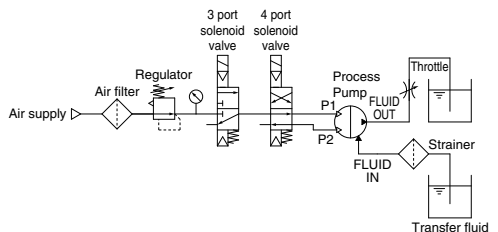

Dimensions

PA3□□0/Automatically Operated Type

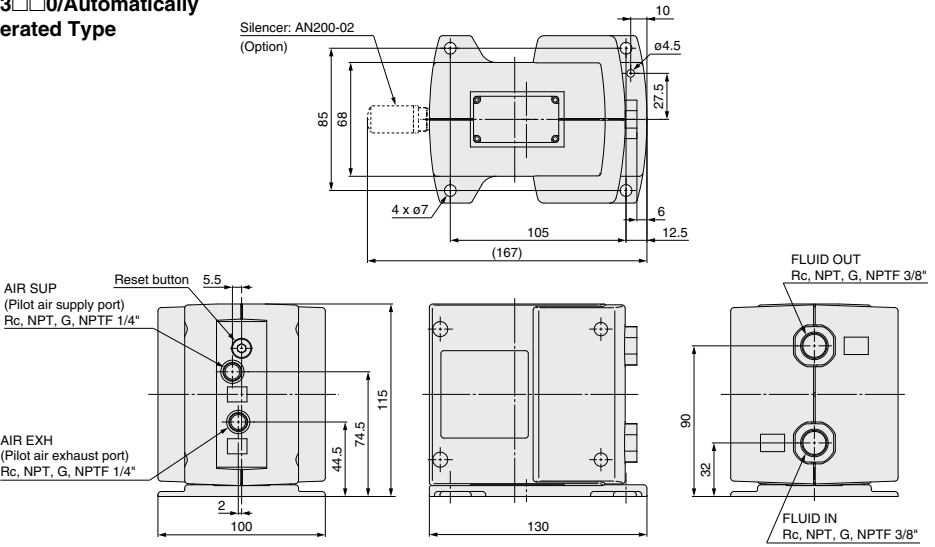

PA
PA(P)
PAX
PB
PAF
PA□
PB

PA3□13/Air Operated Type

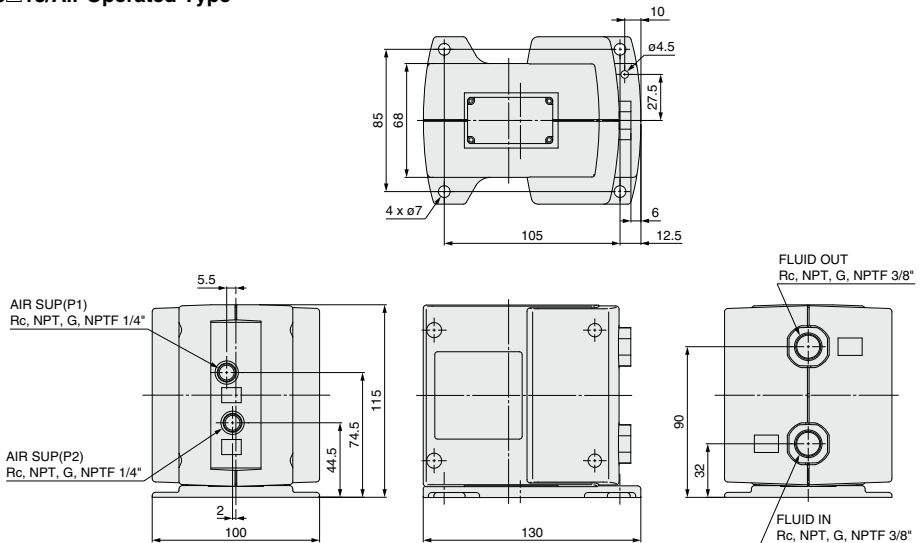

Dimensions

PA5□□0/Automatically Operated Type

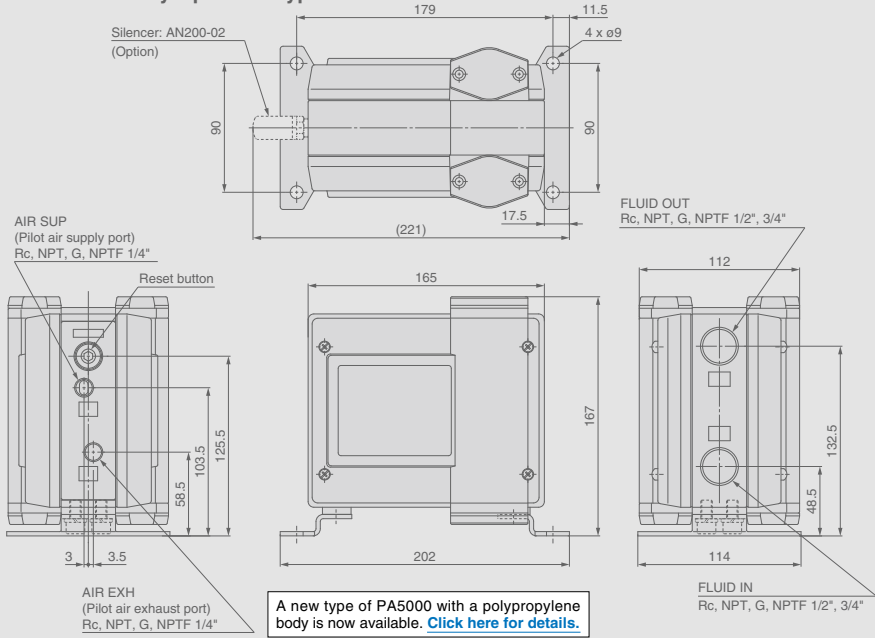

PA5□13/Air Operated Type

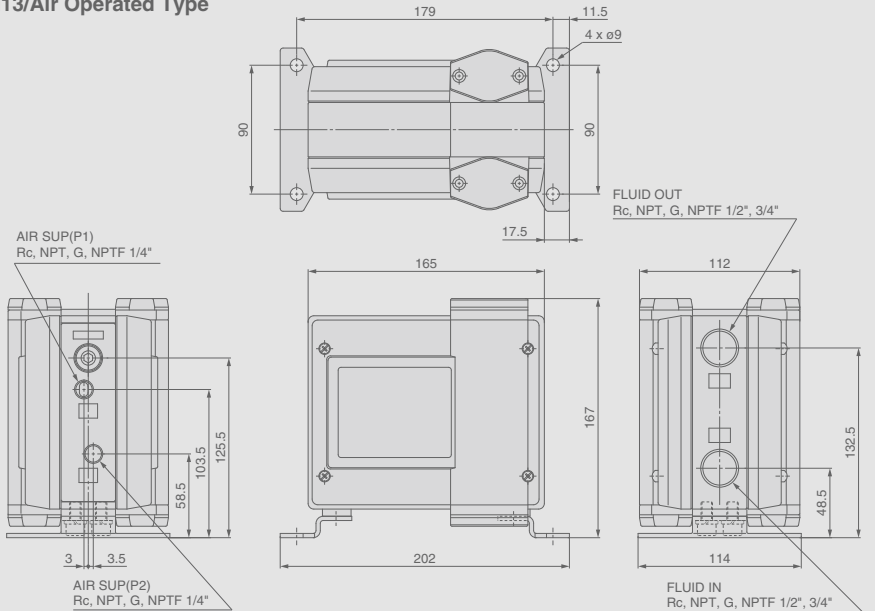

PA3000/5000 Series

Made to Order Specifications

Please contact SMC for detailed dimensions, specifications and lead times.



CE Ex	For 55-PA3□□0: I2G Ex h IIB T6 Gb
	I2D Ex h IIIB T68°C Db
	For 55-PA3□□3: I2G Ex h IIB T5 Gb
	I2D Ex h IIIB T89°C Db
	For 55-PA5□□0: I2G Ex h IIB T6 Gb
	I2D Ex h IIIB T68°C Db
For 55-PA5□□3: I2G Ex h IIB T6 Gb	
I2D Ex h IIIB T78°C Db	
0°C ≤ Ta ≤ +60°C	

CE Ex	For 56-PA3□□0: I3G Ex h IIB T6 Gc
	I3D Ex h IIIB T68°C Dc
	For 56-PA3□□3: I3G Ex h IIB T5 Gc
	I3D Ex h IIIB T89°C Dc
	For 56-PA5□□0: I3G Ex h IIB T6 Gc
	I3D Ex h IIIB T68°C Dc
For 56-PA5□□3: I3G Ex h IIB T6 Gc	
I3D Ex h IIIB T78°C Dc	
0°C ≤ Ta ≤ +60°C	

● PA3000/5000 Series

A new type of PA5000 with a polypropylene body is now available. [Click here for details.](#)

1. Products Complying with ATEX

55-PA3110-□03-□

Products complying with the ATEX Directive

55	Products complying with the ATEX Directive, Category 2
56	Products complying with the ATEX Directive, Category 3

Body size

Symbol	Body size
3	3/8"
5	1/2"

Wetted body material

Symbol	Body material
1	ADC12 (Aluminum)
2	SCS14 (Stainless steel)

Diaphragm material

Symbol	Diaphragm material	Operating method	
		Automatically operated	Air operated
1	PTFE	●	●
2	NBR	●	—

* Dimensions are the same as those of the standard products.

Actuation

Symbol	Actuation
0	Automatic operation
3	Air operated

Option

Symbol	Option	Operating method	
		Automatically operated	Air operated
Nil	None	●	●
N	With silencer*	●	—

* This product is equipped with a 2504-002 (NPT: 2504-N002) silencer.

* For AIR EXH

55-PA: 2504-□002

56-PA: AN20-□02

(□: Either Nil or N is entered as a thread symbol.)

Port size

Symbol	Port size	Applicable model	
		PA3000	PA5000
03	3/8"	●	—
04	1/2"	—	●
06	3/4"	—	●

Thread type

Symbol	Type
Nil	Rc
N	NPT
F	G
T	NPTF

PA

PA(P)

PAX

PB

PAF

PA□
PB

PA3000/5000 Series

A new type of PA5000 with a polypropylene body is now available. [Click here for details.](#)

2. With Air Operated Reset Port

PA 3 1 1 0 - 03 - X2

Body size

Symbol	Body size
3	3/8"
5	1/2"

Wetted body material

Symbol	Body material
1	ADC12 (Aluminum)
2	SCS14 (Stainless steel)

Diaphragm material

Symbol	Diaphragm material
1	PTFE
2	NBR

Thread type

Symbol	Type
Nil	Rc
N	NPT
F	G
T	NPTF

Option

Symbol	Option	
Nil	None	* For AIR EXH: AN20-□02 (□: Either Nil or N is entered as a thread symbol.)
N	With silencer*	

Port size

Symbol	Port size	Applicable model	
		PA3000	PA5000
03	3/8"	●	—
04	1/2"	—	●
06	3/4"	—	●

Made to order specifications
X2 With air operated reset port

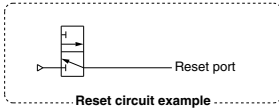

PA3□□0

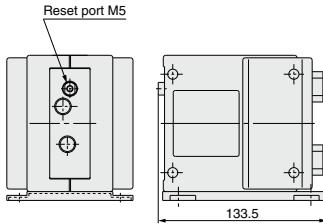

PA5□□0

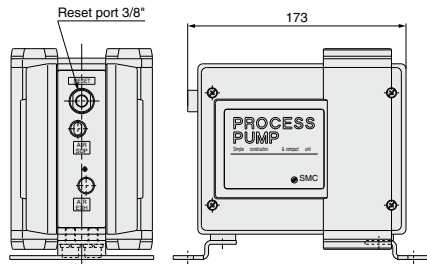

3. With Operating Cycle Counting Port

PA 3 1 1 0 - 03 - X8

Body size

Symbol	Body size
3	3/8"
5	1/2"

Wetted body material

Symbol	Body material
1	ADC12 (Aluminum)
2	SCS14 (Stainless steel)

Diaphragm material

Symbol	Diaphragm material
1	PTFE
2	NBR

Thread type

Symbol	Type
Nil	Rc
N	NPT
F	G
T	NPTF

Option

Symbol	Option	
Nil	None	* For AIR EXH: AN20-□02 (□: Either Nil or N is entered as a thread symbol.)
N	With silencer*	

Port size

Symbol	Port size	Applicable model	
		PA3000	PA5000
03	3/8"	●	—
04	1/2"	—	●
06	3/4"	—	●

Made to order specifications
X8 With Operating Cycle Counting Port

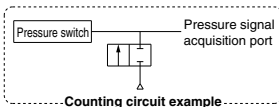

PA3□□0

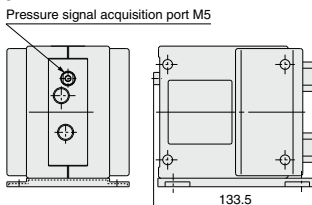

PA5□□0

