

Magnetically Coupled Rodless Cylinder Slider Type: Ball Bushing Bearing

Series CY1L

ø6, ø10, ø15, ø20, ø25, ø32, ø40

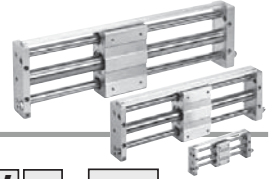

How to Order

Ball Bushing Bearing **CY1L 25** **H** - **300** - **J79W** -

Slider type
(Ball bushing bearing)

Bore size

6	6 mm	25	25 mm
10	10 mm	32	32 mm
15	15 mm	40	40 mm
20	20 mm		

Port thread type

Symbol	Type	Bore size
Nil	M thread	ø6, ø10, ø15
	Rc	ø20, ø25, ø32, ø40
TN	NPT	ø32, ø40
TF	G	

Magnetic holding force

Refer to page 1501 for specifications.

Standard stroke

Refer to "Standard Stroke" on page 1501.

Auto switch

Nil	Without auto switch (Built-in magnet)
-----	--

* For the applicable auto switch model, refer to the table below.

Number of auto switches

Nil	2 pcs.
S	1 pc.
n	"n" pcs.

Refer to page 1501 for details.

Adjustment type

Nil	With adjusting bolt
B	With shock absorbers (2 pcs.)
BS	With shock absorber (With plate A) * Installed on side A at time of shipment.

Shock Absorbers

Type	Bore size (mm)				
	6	10, 15	20	25	32, 40
Standard (shock absorber Series RB)	RB0805	RB1006	RB1411	RB2015	
Shock absorber soft type Series RJ type (-XB22)	RJ0805	RJ0806H	RJ1007H	RJ1412H	—

* The shock absorber service life is different from that of the CY1L cylinder.

Refer to "Specific Product Precautions" for each shock absorber for the replacement period.

* The shock absorber soft type Series RJ type (-XB22) is a made to order specification. For details, refer to page 1722.

Applicable Auto Switches Refer to pages 1559 to 1673 for further information on auto switches.

Type	Special function	Electrical entry	Indicator light	Wiring (Output)	Load voltage		Auto switch model		Lead wire length (m) *				Pre-wired connector	Applicable load						
					DC	AC	Perpendicular	In-line	0.5 (Nil)	3 (L)	5 (Z)	None (N)		IC circuit	Relay, PLC					
																5 V, 12 V	—	●	●	○
Solid state auto switch	—	Grommet	Yes	3-wire (NPN)	5 V, 12 V	—	F7NV	F79	●	●	○	—	○	IC circuit	Relay, PLC					
				3-wire (PNP)			F7PV	F7P	●	●	○	—	○							
		Connector		2-wire	12 V	—	F7BV	J79	●	●	○	—	○							
	Diagnostic indication (2-color indication)	Grommet		3-wire (NPN)	24 V	5 V, 12 V	—	—	●	●	●	●	—			—				
				3-wire (PNP)			F7NWW	F79W	●	●	○	—	○							
				Water resistant (2-color indication)	2-wire	12 V	—	—	F7PW	—	●	●	○			—	○			
With diagnostic output (2-color indication)	Grommet	No	Yes	4-wire (NPN)	5 V, 12 V	—	F7BWW	J79W	●	●	○	—	○	IC circuit	—					
				—			—	F7BAV**	F7BA**	—	●	○	—			○				
				—	—	—	—	F79F	—	●	●	○	—			○				
Reed auto switch	—	Grommet	Yes	3-wire (NPN equivalent)	—	5 V	—	A76H	●	●	—	—	—	IC circuit	—					
				—			—	200 V	A72	A72H	●	●	—			—				
				Connector	No	Yes	2-wire	24 V	12 V	100 V	A73	A73H	●	●	●	—	—	IC circuit	Relay, PLC	
											5 V, 12 V	100 V or less	A80	A80H	●	●	—			—
											12 V	—	A73C	—	●	●	●			●
5 V, 12 V	—	A80C	—	●	●	●	●	—	—											

** Water resistant type auto switches can be mounted on the above models, but in such case SMC cannot guarantee water resistance. Consult with SMC regarding water resistant types with the above model numbers.

* Lead wire length symbols: 0.5 m..... Nil (Example) J79W
3 m..... L (Example) J79WL
5 m..... Z (Example) J79WZ
None..... N (Example) J79CN

* Solid state auto switches marked with "○" are produced upon receipt of order.

• Since there are other applicable auto switches than listed, refer to page 1504 for details.

• For details about auto switches with pre-wired connector, refer to pages 1626 and 1627.

* Auto switches are shipped together, (but not assembled).

1500



Symbol

Rubber bumper
(Magnet type)



Easy piping and wiring

Hollow shafts are used, and centralization of ports on one side makes piping easy. Auto switches can be mounted through the use of special switch rails.

Shock absorbers and adjusting bolt are standard equipment

Impacts at stroke end due to high speed use can be absorbed, and fine adjustment of the stroke is possible.



Made to Order: Individual Specifications
(For details, refer to pages 1522 and 1523.)

Symbol	Specifications
-X116	Hydro specifications
-X168	Helical insert thread specifications
-X322	Outside of cylinder tube with hard chrome plated
-X431	Auto switch rails on both side faces (with 2 pcs.)

Made to Order Specifications
(For details, refer to pages 1699 to 1818.)

Symbol	Specifications
-XB9	Low speed cylinder (15 to 50 mm/s)
-XB13	Low speed cylinder (7 to 50 mm/s)
-XB22	Shock absorber soft type Series RJ type

Amount of Adjustment by Adjusting Bolt

CY1L

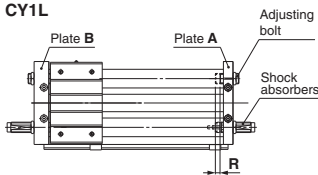

Bore size (mm)	Amount of adjustment by adjusting bolt: R(mm)	
	Single side	Both sides
6	6	12
10	5.5	11
15	3.5	7
20	5.5	11
25	5	10
32	5.5	11
40	4.5	9

- * Since the cylinder is in an intermediate stop condition when stroke adjustment is performed, use caution regarding the operating pressure and the kinetic energy of the load.
- * The amount of adjustment for adjustment bolts is the total amount when adjusted on both plate ends. For the adjustment on a single plate end, the amount of adjustment is half of the figures in the table above.
- * Adjust the stroke adjustment with an adjustment bolt. It cannot be adjusted by a shock absorber.

Specifications

Bore size (mm)	6	10	15	20	25	32	40	
Fluid	Air							
Proof pressure	1.05 MPa							
Maximum operating pressure	0.7 MPa							
Minimum operating pressure	0.18 MPa							
Ambient and fluid temperature	-10 to 60°C (No freezing)							
Piston speed *	50 to 500 mm/s							
Cushion	Rubber bumper/Shock absorber							
Lubrication	Not required (Non-lube)							
Stroke length tolerance (mm)	0 to 250 st: $^{+1.0}_0$, 251 to 1000 st: $^{+1.4}_0$, 1001 st and up: $^{+1.8}_0$							
Holding force (N)	Type H	19.6	53.9	137	231	363	588	922
	Type L	-	-	81.4	154	221	358	569
Standard equipment	Auto switch mounting rail							

* In the case of setting an auto switch at the intermediate position, the maximum piston speed is subject to restrict for detection upon the response time of a load (Relays, Sequence controller, etc.).

Standard Stroke

Bore size (mm)	Standard stroke (mm)	Maximum available stroke (mm)
6	50, 100, 150, 200	300
10	50, 100, 150, 200, 250, 300	500
15	50, 100, 150, 200, 250, 300, 350 400, 450, 500	750
20	100, 150, 200, 250, 300, 350 400, 450, 500, 600, 700, 800	1000
25		1500
32	100, 150, 200, 250, 300, 350 400, 450, 500, 600, 700, 800 900, 1000	1500
40		1500

Note) Intermediate stroke is available by the 1 mm interval.

Weight

Bore size (mm)	(kg)							
	6	10	15	20	25	32	40	
Number of magnets	6	10	15	20	25	32	40	
Basic weight	CY1L \square H	0.324	0.580	1.10	1.85	2.21	4.36	4.83
	CY1L \square L	—	—	1.02	1.66	2.04	4.18	4.61
Additional weight per each 50mm of stroke	0.044	0.077	0.104	0.138	0.172	0.267	0.406	

Calculation

(Example) **CY1L32H-500**

• Basic weight 4.36 kg • Additional weight 0.267/50 st • Cylinder stroke 500 st
4.36 + 0.267 x 500 ÷ 50 = 7.03 kg

Shock Absorber Specifications

Refer to the Series RB in Best Pneumatics No. 3 for the details on shock absorbers.

Applicable rodless cylinder	CY1L $\frac{6}{15}$	CY1L20	CY1L25	CY1L $\frac{32}{40}$	
Shock absorber model	RB0805	RB1006	RB1411	RB2015	
Maximum energy absorption: (J)	0.98	3.92	14.7	58.8	
Stroke absorption: (mm)	5	6	11	15	
Collision speed: (m/s)	0.05 to 5				
Max. operating frequency: (cycle/min) *	80	70	45	25	
Ambient temperature range	-10 to 80 °C				
Spring force: (N)	Extended	1.96	4.22	6.86	8.34
	Retracted	3.83	6.18	15.3	20.50

* It denotes the values at the maximum energy absorption per one cycle. Therefore, the operating frequency can be increased according to the energy absorption.

The shock absorber service life is different from that of the CY1L cylinder. Refer to the Specific Product Precautions for the replacement period.



CY3B
CY3R
CY1S
-Z
CY1L
CY1H
CY1F
CYP
D-
-X
Technical data

Series CY1L

Construction

Slider type/Ball bushing bearing

CY1L6

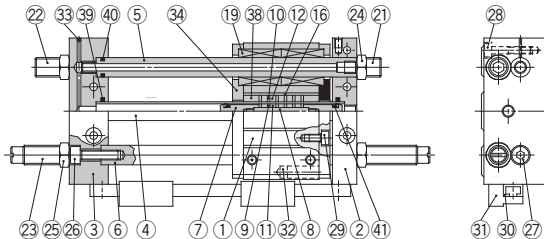

CY1L10 to 40

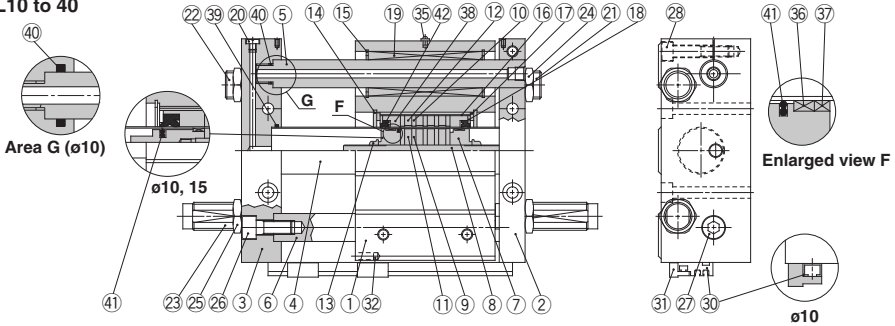

Component Parts

No.	Description	Material	Note
1	Slide block	Aluminum alloy	Anodized
2	Plate A	Aluminum alloy	Anodized
3	Plate B	Aluminum alloy	Anodized
4	Cylinder tube	Stainless steel	
5	Guide shaft A	Carbon steel	Hard chrome plated
6	Guide shaft B	Carbon steel	Hard chrome plated
7	Piston	Aluminum alloy ^{Note 1)}	Chromated
8	Shaft	Stainless steel	
9	Piston side yoke	Rolled steel	Zinc chromated
10	External slider side yoke	Rolled steel	Zinc chromated
11	Magnet A	—	
12	Magnet B	—	
13	Piston nut	Carbon steel	Zinc chromated ø25 to ø40
14	Retaining ring	Carbon tool steel	Phosphate coated
15	Retaining ring	Carbon tool steel	Phosphate coated
16	External slider tube	Aluminum alloy	
17	Slider spacer	Rolled steel	Nickel plated
18	Spacer	Rolled steel	Nickel plated
19	Ball bushing	—	
20	Plug	Brass	ø25, ø32, ø40 only
21	Adjusting bolt A	Chromium molybdenum steel	Nickel plated
22	Adjusting bolt B	Chromium molybdenum steel	Nickel plated
23	Shock absorber	—	
24	Hexagon nut	Carbon steel	Nickel plated
25	Hexagon nut	Carbon steel	Nickel plated
26	Hexagon socket head cap screw	Chromium molybdenum steel	Nickel plated
27	Hexagon socket head cap screw	Chromium molybdenum steel	Nickel plated
28	Hexagon socket head cap screw	Chromium molybdenum steel	Nickel plated

Note 1) Brass for ø6

No.	Description	Material	Note
29	Hexagon socket head cap screw	Chromium molybdenum steel	Nickel plated
30	Switch mounting rail	Aluminum alloy	
31	Auto switch	—	
32	Magnet for auto switch	—	
33	Steel ball	—	ø6, ø10, ø15 only
34	Side cover	Carbon steel	ø6 only
35	Grease cup	Carbon steel	ø15 or larger
36*	Wear ring A	Special resin	
37*	Wear ring	Special resin	
38*	Wear ring B	Special resin	
39*	Cylinder tube gasket	NBR	
40*	Guide shaft gasket	NBR	
41*	Piston seal	NBR	
42*	Scraper	NBR	

Replacement Parts: Seal Kit

Bore size (mm)	Kit no.	Contents
6	CY1S6-PS-N	Set of nos. above 38, 39, 40, 41
10	CY1L10-PS-N	Set of nos. above 38, 39, 40, 41, 42
15	CY1L15-PS-N	
20	CY1L20-PS-N	Set of nos. above
25	CY1L25-PS-N	36, 37, 38, 39, 40,
32	CY1L32-PS-N	41, 42
40	CY1L40-PS-N	

Note 1) Seal kit includes 38, 39, 40, 41 for ø6, 36, 38 to 42 are for ø10, ø15.
36 to 42 are for ø20 to ø40. Order the seal kit, based on each bore size.

Note 2) ø6: Same for CY1S6

Note 3) For replacement of the ø10 wear ring A, contact SMC or your nearest sales representative.

* Seal kit includes a grease pack (ø6, ø10: 5 and 10 g, ø15 to ø40: 10 g).
Order with the following part number when only the grease pack is needed.
Grease pack part no. for ø6, ø10: GR-F-005 (5 g) for external sliding parts,
GR-S-010 (10 g) for tube interior
Grease pack part no. for ø15 to ø40: GR-S-010 (10 g)

Dimensions

Slider type/Ball bushing bearing

CY1L6/10

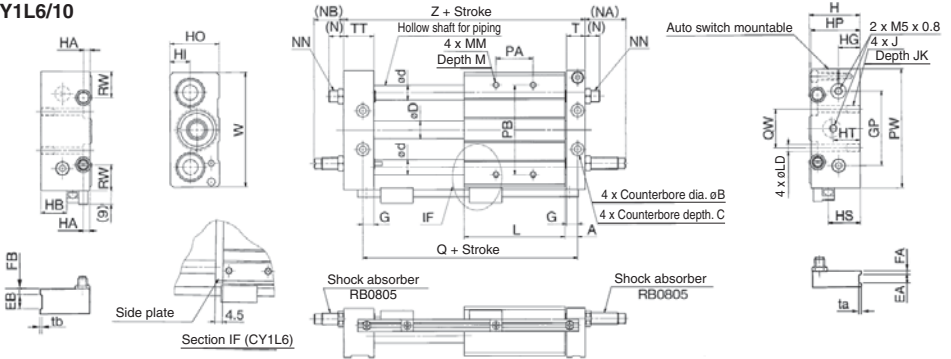

Model	A	B	C	D	d	EA	EB	FA	FB	G	GP	H	HA	HB	HG	HI	HO	HP	HS	HT	J	JK
CY1L6	7	6.5	3	7.6	8	—	—	—	6	36	27	6	10	11	9	25	26	14	16	M4 x 0.7	6.5	—
CY1L10	8.5	8	4	12	10	6	12	3	5	7.5	50	34	6	17.5	14.5	13.5	33	33	21.5	18	M5 x 0.8	9.5

Model	L	LD	M	MM	(N)	(NA)	(NB)	NN	PA*	PB	PW	Q	QW	RW	T	TT	ta	tb	W	Z
CY1L6	40	3.5	6	M4 x 0.7	11	30	24	M8 x 1.0	24	40	60	54	20	12	10	16	—	—	56	68
CY1L10	68	4.3	8	M4 x 0.7	10.5	27	19	M8 x 1.0	30	60	80	85	26	17.5	12.5	20.5	0.5	1.0	77	103

* PA dimensions are for split from center.

CY1L15/20/25/32/40

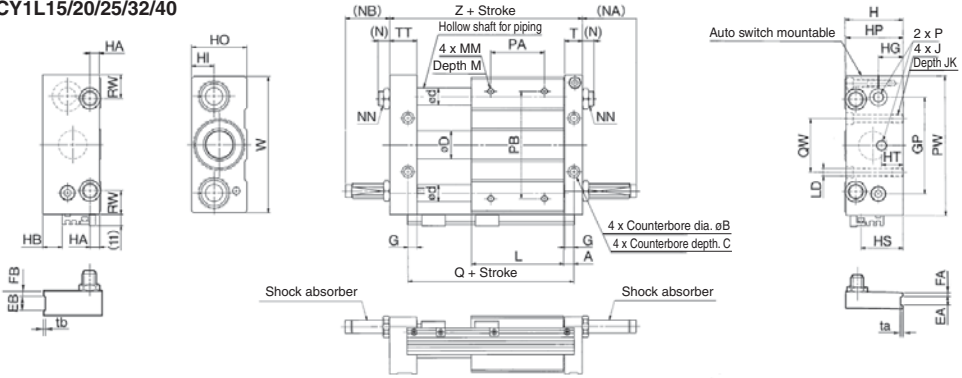

Model	A	B	C	D	d	EA	EB	FA	FB	G	GP	H	HA	HB	HG	HI	HO	HP	HS	HT	J	JK	L	LD
CY1L15	7.5	9.5	5	16.6	12	6	13	3	6	6.5	65	40	6.5	4	16	14	38	39	25	16	M6 x 1.0	9.5	7.5	5.6
CY1L20	9.5	9.5	5.2	21.6	16	—	—	—	8.5	80	46	9	10	18	16	44	45	31	20	—	M6 x 1.0	10	86	5.6
CY1L25	9.5	11	6.5	26.4	16	8	14	4	7	8.5	90	54	9	18	23	21	52	53	39	20	M8 x 1.25	10	86	7
CY1L32	10.5	14	8	33.6	20	8	16	5	7	9.5	110	66	12	26.5	26.5	24.5	64	64	47.5	25	M10 x 1.5	15	100	9.2
CY1L40	11.5	14	8	41.6	25	10	20	5	10	10.5	130	78	12	35	30.5	28.5	76	74	56	30	M10 x 1.5	15	136	9.2

Model	M	MM	(N)	(NA)	(NB)	NN	P	PA*	PB	PW	Q	QW	RW	T	ta	tb	TT	W	Z	Shock absorber
CY1L15	8	M5 x 0.8	8.5	27	17	M8 x 1.0	M5 x 0.8	45	70	95	90	30	15	12.5	0.5	1.0	22.5	92	112	RB0805
CY1L20	10	M6 x 1.0	10.5	29	20	M10 x 1.0	Rc 1/8	50	90	120	105	40	28	16.5	—	—	25.5	117	130	RB1006
CY1L25	10	M6 x 1.0	12.5	49	40	M14 x 1.5	Rc 1/8	60	100	130	105	50	22	16.5	0.5	1.0	25.5	127	130	RB1411
CY1L32	12	M8 x 1.25	13.5	52	42	M20 x 1.5	Rc 1/8	70	120	160	121	60	33	18.5	0.5	1.0	28.5	157	149	RB2015
CY1L40	12	M8 x 1.25	12.5	51	36	M20 x 1.5	Rc 1/4	90	140	190	159	84	35	20.5	1.0	1.0	35.5	187	194	RB2015

* PA dimensions are for split from center.

- CY3B
- CY3R
- Z
- CY1L
- CY1H
- CY1F
- CYP

- D
- X
- Technical data

Series CY1L Auto Switch Mounting

Proper Auto Switch Mounting Position (Detection at stroke end)

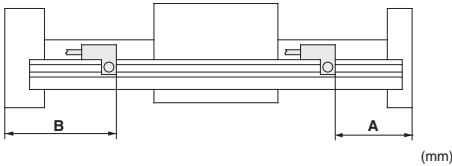

Bore size (mm)	Applicable auto switch					
	D-A73/A80		D-A72 D-A7□H/A80H D-A73C/A80C D-F7□J/J79 D-F7□V/J79C D-F7□W/J79W D-F7□WV D-F7BA/F7BAV D-F79F		D-F7NT	
	A	B	A	B	A	B
6	23	45	23.5	44.5	28.5	39.5
10	58	45	58.5	44.5	63.5	39.5
15	65	47	65.5	46.5	70.5	41.5
20	76	54	76.5	53.5	81.5	48.5
25	76	54	76.5	53.5	81.5	48.5
32	92	57	92.5	56.5	97.5	51.5
40	130	64	130.5	63.5	135.5	58.5

Note 1) 50 mm is the minimum stroke available with 2 auto switches mounted.
In the case of a stroke less than this, please contact SMC.

Note 2) Adjust the auto switch after confirming the operating conditions in the actual setting.

Mounting of Auto Switch

When mounting an auto switch, the auto switch mounting screw should be screwed into a hexagon nut (M3 x 0.5) which has been inserted into the groove of the switch mounting rail. (Tightening torque: Approx. 0.5 to 0.7 N·m)

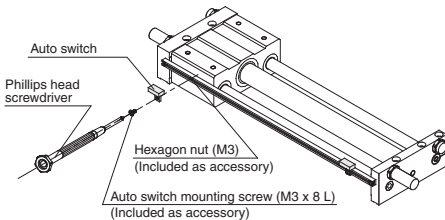

Operating Range

Auto switch model	Bore size (mm)						
	6	10	15	20	25	32	40
D-A7□/A8□	6	6	6	6	6	6	6
D-F7□/J7□	3	3	4	3	3	3	3.5
D-F79F	4.5	4.5	4.5	4.5	4.5	4.5	4.5

* Since this is a guideline including hysteresis, not meant to be guaranteed. (Assuming approximately ±30% dispersion)
There may be the case it will vary substantially depending on an ambient environment.

Other than the models listed in "How to Order", the following auto switches are applicable.
For detailed specifications, refer to page 1611.

Type	Model	Electrical entry (Fetching direction)	Features
Solid state auto switch	D-F7NT	Grommet (In-line)	With timer

* With pre-wired connector is available for D-F7NT type, too.
For details, refer to pages 1626 and 1627.