

Speed Controller with One-touch Fitting Stainless Steel Type Push-lock type Elbow Type/Universal Type **AS-FG Series**



Model

Model		Port size	Seal method	Applicable tubing O.D.														
Elbow type	Universal type			Metric size						Inch size								
AS12□1FG-M5	AS13□1FG-M5	M5 x 0.8	Gasket seal	2 Note 2	3.2	4	6	8	10	12	16	1/8"	5/32"	1/4"	5/16"	3/8"	1/2"	
AS12□1FG-U10/32	AS13□1FG-U10/32	10-32UNF		● Note 3	●	●	●						●	●	●			
AS22□1FG-□01	AS23□1FG-□01	R NPT	Sealant						● Note 3									
AS22□1FG-□02	AS23□1FG-□02			1/8														
AS32□1FG-□02	AS33□1FG-□02			1/4	● Note 3	●	●	●						● Note 3	●	●	●	
AS32□1FG-□03	AS33□1FG-□03			1/4														
AS32□1FG-□03	AS33□1FG-□03	3/8																
AS42□1FG-□04	AS43□1FG-□04	1/2															●	
AS22□1FG-G01	AS23□1FG-G01	G	Face seal		●	●	●	●	● Note 3									
AS22□1FG-G02	AS23□1FG-G02			1/8	● Note 3	●	●	●	●									
AS32□1FG-G02	AS33□1FG-G02			1/4														
AS32□1FG-G03	AS33□1FG-G03			1/4														
AS32□1FG-G03	AS33□1FG-G03			3/8														
AS42□1FG-G04	AS43□1FG-G04			1/2														

Note 1) "Without sealant" type can be selected as a standard option.

Note 2) Only polyurethane tubing is applicable for ø2.

Note 3) Universal type is not available.

Flow Direction Symbols on Body

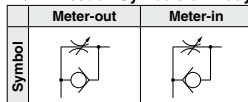

Specifications

Fluid	Air
Proof pressure	1.5 MPa
Max. operating pressure	1 MPa
Min. operating pressure	0.1 MPa
Ambient and fluid temperature	-5 to 60°C (No freezing)
Applicable tubing material	Nylon, Soft nylon, Polyurethane Note), FEP, PFA

Note) Use caution at the max. operating pressure when using soft nylon or polyurethane tubing.
(Refer to pages 464 and 465 for details.)

Flow Rate and Sonic Conductance

Model	AS12□1FG-M5 AS13□1FG-M5		AS22□1FG-□01 AS23□1FG-□01		AS22□1FG-□02 AS23□1FG-□02		AS32□1FG AS33□1FG		AS42□1FG AS43□1FG						
	Metric size	ø2 ø4 ø6	ø3.2 ø4 ø6	ø6 ø8 ø10	ø3.2 ø4 ø6	ø8 ø10	ø6 ø8 ø10 ø12	ø6 ø8 ø10 ø12	ø10 ø12	ø12 ø16					
Tubing O.D.	Inch size	—	ø1/8" ø1/4" ø5/32"	ø1/8" ø5/32" ø1/4" ø5/16"	ø1/8" ø5/32"	—	ø1/4" ø5/16" ø3/8"	ø1/4" ø5/16"	ø3/8" ø3/8"	ø1/2"					
C values: Sonic conductance (dm ³ /sbar)	Free flow	0.2	0.3	0.4	0.6	0.6	0.7	1.0	1.3	1.5	1.6	1.7	2.5	4.4	4.8
	Controlled flow	0.2	0.3	0.4	0.7	0.8	0.6	0.9	1.3	2.1	2.4	3.3	4.4	4.9	
b values: Critical pressure ratio	Free flow	0.3	0.4	0.2	0.3		0.3		0.4		0.4	0.3		0.3	
	Controlled flow		0.2	0.2	0.3		0.3		0.3		0.3		0.3		

Note 1) 10-32UNF has the same specification as M5.

Note 2) C and b values are for controlled flow with the needle fully open and free flow with the needle fully closed.

⚠ Caution

Be sure to read this before handling the products. Refer to back page 50 for Safety Instructions, pages 543 to 546 for Flow Control Equipment Precautions, and pages 573 to 575 for Specific Product Precautions.

AS-FG Series



How to Order

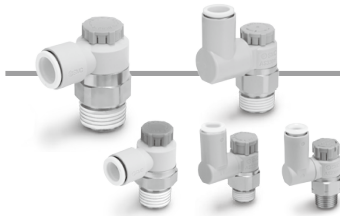

Body size

1	M5 x 0.8 10-32UNF
---	----------------------

Port size

M5	M5 x 0.8
U10/32	10-32UNF

Applicable tubing O.D. Note 1)

Metric size		Inch size	
02	ø2	01	ø1/8"
23	ø3.2 <small>Note 2)</small>	03	ø5/32"
04	ø4	07	ø1/4"
06	ø6		

Note 1) For selecting applicable tubing O.D., refer to the "Model" on page 667. The color of the release button is white (metric, inch).
Note 2) Use ø1/8" tube.

Body size 1

Body size 2/3/4

AS 1 2 0 1 FG - M5 - 06 A -

AS 2 2 0 1 FG - 01 - 06 S A -

Body size

2	1/8, 1/4
3	3/8
4	1/2

Type

2	Elbow
3	Universal

Control type Note)

0	Meter-out
1	Meter-in

Note) Meter-out and meter-in types can be visually identified by color of the knob.
Meter-out: Gray
Meter-in: Light blue

Stainless steel type (Stainless steel 303)

Note 1) The material can be visually identified by color of the release button.
Stainless steel type: White
Note 2) White is also used for inch size.

Thread type

Nil	R
N	NPT
G	G

Made to Order
Refer to page 678 for details.

Push-lock type

Seal method

Nil	Without sealant
S	With sealant

Note) Face seal method is used for the G thread type.
Select "Nil/Without sealant."
Example) AS2201FG-G01-06A

Applicable tubing O.D. Note 1)

Metric size		Inch size <small>Note 3)</small>	
23	ø3.2 <small>Note 2)</small>	01	ø1/8"
04	ø4	03	ø5/32"
06	ø6	07	ø1/4"
08	ø8	09	ø5/16"
10	ø10	11	ø3/8"
12	ø12	13	ø1/2"
16	ø16		

Note 1) For selecting applicable tubing O.D., refer to the "Model" on page 667. The color of the release button is white (metric, inch).
Note 2) Use ø1/8" tube.
Note 3) Only the metric size is available for the G thread type.

Port size

01	1/8
02	1/4
03	3/8
04	1/2



Made to Order
(For details, refer to page 678.)

Symbol	Specifications
-X12	Lubricant: Vaseline
-X21	Grease-free (Seal: Fluorine-coated) + Restrictor (Without check valve)
-X214	Restrictor (Without check valve)
10-	Clean Series

Needle Valve/Flow Rate Characteristics

**AS1201FG-M5, AS1211FG-M5
AS1301FG-M5, AS1311FG-M5**

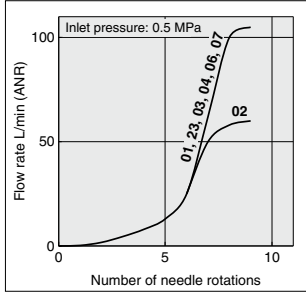

Note) -U10/32 has the same specification as M5.

**AS2201FG-01, AS2211FG-01
AS2301FG-01, AS2311FG-01**

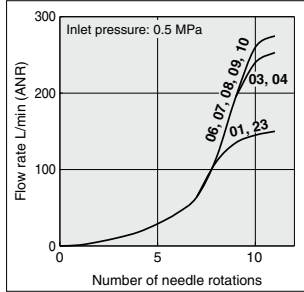

**AS2201FG-02, AS2211FG-02
AS2301FG-02, AS2311FG-02**

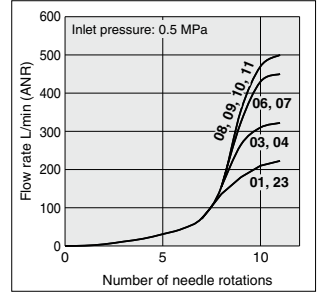

**AS3201FG, AS3211FG
AS3301FG, AS3311FG**

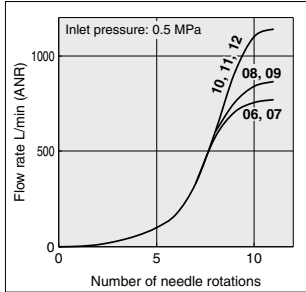

**AS4201FG, AS4211FG
AS4301FG, AS4311FG**

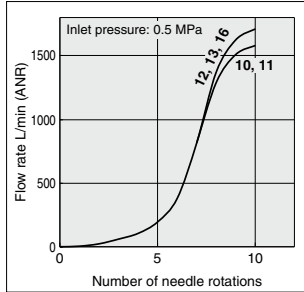

Note) The numbers above the flow rate characteristic curves in the charts show the applicable tubing outside diameter as defined by the product number.

- AS-F
- TMH
- ASD
- AS
- AS-FE
- KE
- AS-FG
- AS-FP
- AS-FM
- AS-D
- AS-T
- ASP
- ASN
- AQ
- ASV
- AK
- VCHC
- ASR
- ASQ

AS-FG Series

Construction

Elbow type

Seal method: Gasket seal
For M5, 10-32UNF

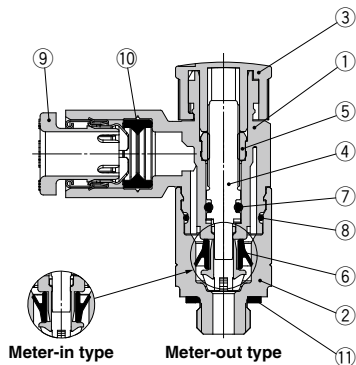

Seal method: Sealant
For R, NPT thread

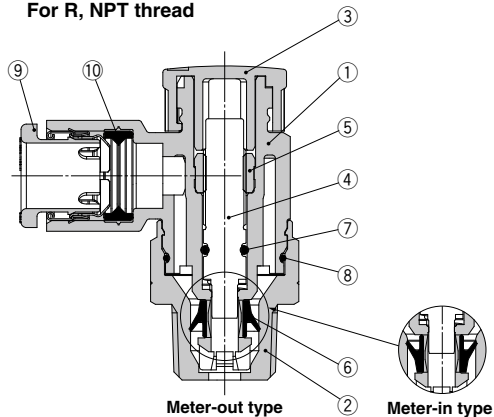

Seal method: Face seal
For G thread

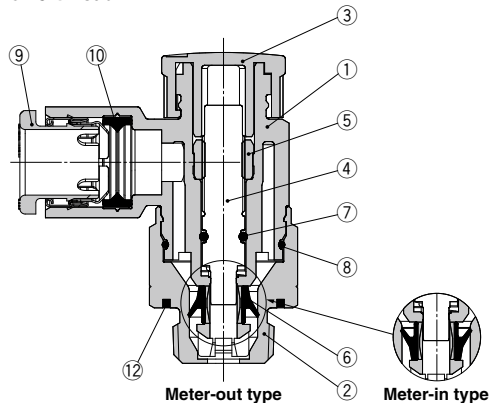

Component Parts

No.	Description	Material	Note
1	Body A	PBT	
2	Body B	Stainless steel	
3	Knob	POM	
4	Needle	PBT	
5	Needle guide	Stainless steel	
6	U-seal	HNBR	
7	O-ring	NBR	
8	O-ring	NBR	
9	Cassette	—	
10	Seal	NBR	
11	Gasket	NBR/Stainless steel	
12	Seal	NBR	

Construction

Universal type

Seal method: Gasket seal
For M5, 10-32UNF

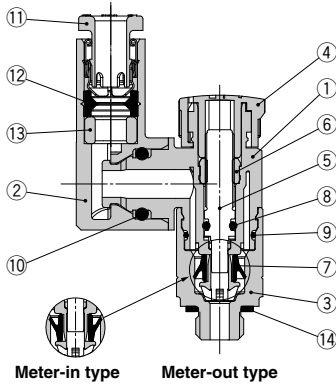

Seal method: Sealant
For R, NPT thread

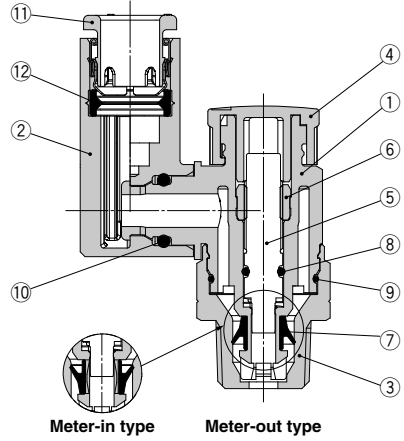

Seal method: Face seal
For G thread

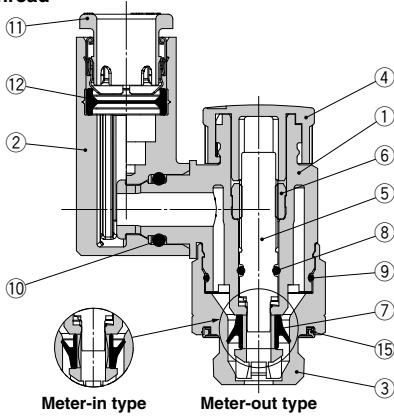

Component Parts

No.	Description	Material	Note
1	Body A	PBT	
2	Elbow body	PBT	
3	Body B	Stainless steel	
4	Knob	POM	
5	Needle	PBT	
6	Needle guide	Stainless steel	
7	U-seal	HNBR	
8	O-ring	NBR	
9	O-ring	NBR	
10	O-ring	NBR	
11	Cassette	—	
12	Seal	NBR	
13	Spacer ^{Note)}	PBT	
14	Gasket	NBR/Stainless steel	
15	Seal	NBR	

Note) Spacer is included only for the applicable tubing O.D. ø3.2, ø1/8", ø4, ø5/32" and ø6.

AS-F
TMH
ASD
AS
AS-FE
KE
AS-FG
AS-FP
AS-FM
AS-D
AS-T
ASP
ASN
AQ
ASV
AK
VCHC
ASR
ASQ

AS-FG Series For M5, 10-32UNF

Dimensions/ Elbow type

Seal method: Gasket seal
For M5, 10-32UNF

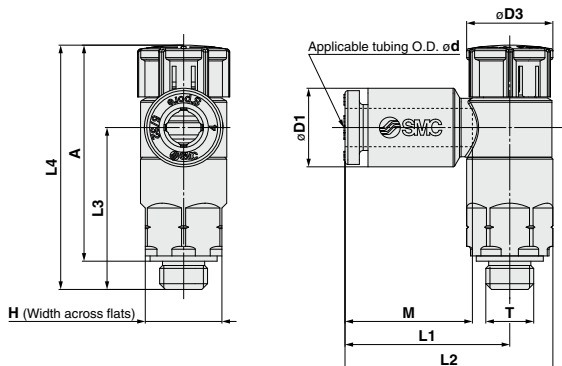

Metric Size

Model	d	T	H	D1	D3	L1	L2	L3	L4 <small>Note 1)</small>		A <small>Note 2)</small>		M	Weight [g]
									Unlocked	Locked	Unlocked	Locked		
AS12□1FG-M5-02A	2	M5 x 0.8 10/32UNF	8	5.8	9.4	15.8	20.3	16.9	26.5	25.4	23.5	22.4	11.9	5
AS12□1FG-U10/32-02A														
AS12□1FG-M5-23A	3.2			7.2										
AS12□1FG-U10/32-23A														
AS12□1FG-M5-04A	4			8.2										
AS12□1FG-U10/32-04A														
AS12□1FG-M5-06A	6	10.4	18.6	23.1	16.5									
AS12□1FG-U10/32-06A														

Note 1) Reference dimensions

Note 2) Reference dimensions of threads after installation

Inch Size

Model	d	T	H	D1	D3	L1	L2	L3	L4 <small>Note 1)</small>		A <small>Note 2)</small>		M	Weight [g]			
									Unlocked	Locked	Unlocked	Locked					
AS12□1FG-M5-01A	1/8"	M5 x 0.8 10/32UNF	8	7.2	9.4	17.2	21.7	16.9	26.5	25.4	23.5	22.4	13.3	5			
AS12□1FG-U10/32-01A																	
AS12□1FG-M5-03A	5/32"			8.2													
AS12□1FG-U10/32-03A																	
AS12□1FG-M5-07A	1/4"			11.2											18.6	23.1	16.5
AS12□1FG-U10/32-07A																	

Note 1) Reference dimensions

Note 2) Reference dimensions of threads after installation

Dimensions/ Universal type

Seal method: Gasket seal
For M5, 10-32UNF

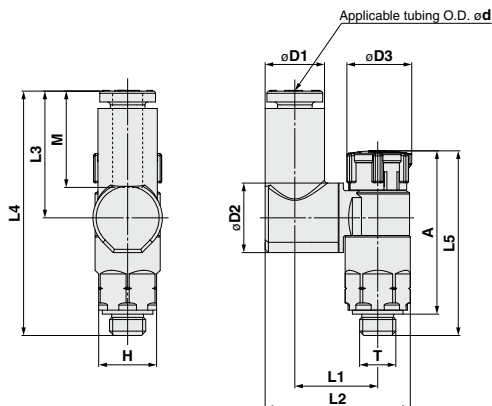

Metric Size

Model	d	T	H	D1	D2	D3	L1	L2	L3	L4	L5 Note 1)		A Note 2)		M	Weight [g]
											Unlocked	Locked	Unlocked	Locked		
AS13□1FG-M5-23A	3.2	M5 x 0.8 10/32UNF	8	7.2	9.6	9.4	11.6	19.7	17.5	33.8	26.5	25.4	23.5	22.4	13.3	6
AS13□1FG-U10/32-23A				8.2												
AS13□1FG-M5-04A	4			8.2			11.5	20.1								
AS13□1FG-U10/32-04A				8.2												
AS13□1FG-M5-06A	6			10.4			11.5	21.2	20.4	36.6						
AS13□1FG-U10/32-06A		10.4														

Note 1) Reference dimensions

Note 2) Reference dimensions of threads after installation

Inch Size

Model	d	T	H	D1	D2	D3	L1	L2	L3	L4	L5 Note 1)		A Note 2)		M	Weight [g]
											Unlocked	Locked	Unlocked	Locked		
AS13□1FG-M5-01A	1/8"	M5 x 0.8 10/32UNF	8	7.2	9.6	9.4	11.6	19.7	17.5	33.8	26.5	25.4	23.5	22.4	13.3	6
AS13□1FG-U10/32-01A				8.2												
AS13□1FG-M5-03A	5/32"			8.2			11.5	20.1								
AS13□1FG-U10/32-03A				8.2												
AS13□1FG-M5-07A	1/4"			11.2			11.5	21.6	20.2	36.5						
AS13□1FG-U10/32-07A		11.2														

Note 1) Reference dimensions

Note 2) Reference dimensions of threads after installation

- AS-F
- TMH
- ASD
- AS
- AS-FE
- KE
- AS-FG**
- AS-FP
- AS-FM
- AS-D
- AS-T
- ASP
- ASN
- AQ
- ASV
- AK
- VCHC
- ASR
- ASQ

AS-FG Series For R, NPT thread

Dimensions/ Elbow type

Seal method: Sealant
For R, NPT thread

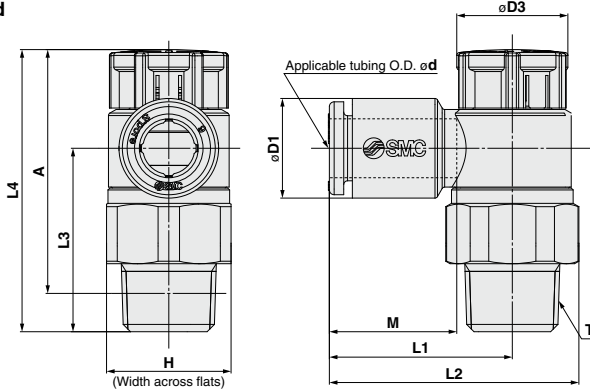

Metric Size

Model	d	T	H	D1	D3	L1	L2	L3	L4 Note 1)		A Note 1)		M	Weight [g]
									Unlocked	Locked	Unlocked	Locked		
AS22□1FG-01-23(S)A	3.2	1/8	13 (12.7)	7.2	12	19.1	26.2	19.1	30.6	29.2	27.5	26.1	13.3	9 (9)
AS22□1FG-01-04(S)A	4			8.2										10 (9)
AS22□1FG-01-06(S)A	6			10.4										11 (10)
AS22□1FG-01-08(S)A	8			13.2										12 (11)
AS22□1FG-01-10(S)A	10	15.9	15.9	32.4										
AS22□1FG-02-23(S)A	3.2	1/4	17 (17.5)	7.2	13	20.9	30.2 (30.3)	22.6	36.6	35	31.1	29.5	13.3	17 (18)
AS22□1FG-02-04(S)A	4			8.2										17 (18)
AS22□1FG-02-06(S)A	6			10.4										18 (19)
AS22□1FG-02-08(S)A	8			13.2										19 (20)
AS22□1FG-02-10(S)A	10	15.9	15.9	36.3)										
AS32□1FG-02-06(S)A	6	1/4	19	10.4	16.6	21.8	32.1	36.4	50	48.4	44.5	42.9	13.3	40 (40)
AS32□1FG-02-08(S)A	8			13.2										41 (41)
AS32□1FG-02-10(S)A	10			15.9										42 (42)
AS32□1FG-02-12(S)A	12			18.5										43 (43)
AS32□1FG-03-06(S)A	6	3/8	19	10.4	16.6	21.8	32.1	28.7	42.3	40.7	37.1	35.5	13.3	29 (30)
AS32□1FG-03-08(S)A	8			13.2										30 (31)
AS32□1FG-03-10(S)A	10			15.9										31 (32)
AS32□1FG-03-12(S)A	12			18.5										32 (33)
AS42□1FG-04-10(S)A	10	1/2	24 (23.8)	15.9	18.8	27.4	40.3 (40.2)	36.2	50.8	49.2	43.7	42.1	15.6	52 (51)
AS42□1FG-04-12(S)A	12			18.5										53 (53)
AS42□1FG-04-14(S)A	14			23.8										54 (54)
AS42□1FG-04-16(S)A	16			34.8										58 (57)

Note 1) Reference dimensions Note 2) Reference dimensions of threads after installation Note 3) The values in () are for NPT thread.

Inch Size

Model	d	T	H	D1	D3	L1	L2	L3	L4 Note 1)		A Note 2)		M	Weight [g]
									Unlocked	Locked	Unlocked	Locked		
AS22□1FG-01-01(S)A	1/8"	1/8	13 (12.7)	7.2	12	19.1	26.2	19.1	30.6	29.2	27.5	26.1	13.3	9 (9)
AS22□1FG-01-03(S)A	5/32"			8.2										10 (9)
AS22□1FG-01-07(S)A	1/4"			11.2										11 (10)
AS22□1FG-01-09(S)A	5/16"			13.2										12 (11)
AS22□1FG-02-01(S)A	1/8"	1/4	17 (17.5)	7.2	13	20.9	30.2 (30.3)	22.6	36.6	35	31.1	29.5	13.3	17 (18)
AS22□1FG-02-03(S)A	5/32"			8.2										18 (19)
AS22□1FG-02-07(S)A	1/4"			11.2										19 (20)
AS22□1FG-02-09(S)A	5/16"			13.2										20 (21)
AS22□1FG-02-11(S)A	3/8"	15.5	15.5	35.8)										
AS32□1FG-02-07(S)A	1/4"	1/4	19	11.2	16.6	21.8	32.1	36.4	50	48.4	44.5	42.9	13.3	40 (40)
AS32□1FG-02-09(S)A	5/16"			13.2										41 (41)
AS32□1FG-02-11(S)A	3/8"			15.5										42 (43)
AS32□1FG-03-07(S)A	1/4"			11.2										43 (43)
AS32□1FG-03-09(S)A	5/16"	3/8	19	13.2	16.6	22.7	33	28.7	42.3	40.7	37.1	35.5	13.3	29 (30)
AS32□1FG-03-11(S)A	3/8"			15.5										30 (31)
AS42□1FG-04-11(S)A	3/8"			11.2										31 (32)
AS42□1FG-04-13(S)A	1/2"			15.5										32 (33)
AS42□1FG-04-13(S)A	1/2"	1/2	24 (23.8)	15.5	18.8	27.4	40.3 (40.2)	36.2	50.8	49.2	43.7	42.1	15.6	52 (51)
AS42□1FG-04-13(S)A	3/8"			19.3										54 (53)

Note 1) Reference dimensions Note 2) Reference dimensions of threads after installation Note 3) The values in () are for NPT thread.

Dimensions/ Universal type

Seal method: Sealant
For R, NPT thread

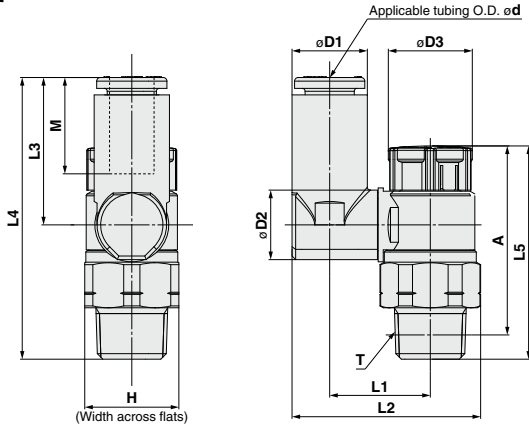

Metric Size

Model	d	T	H	D1	D2	D3	L1	L2	L3	L4	L5 Note 1)		A Note 2)		M	Weight [g]			
											Unlocked	Locked	Unlocked	Locked		(g)			
AS23□1FG-01-23(S)A	3.2	1/8	13 (12.7)	7.2	9.6	12	13.3	24	17.5	36	30.6	29.2	27.5	26.1	13.3	10 (9)			
AS23□1FG-01-04(S)A	4			8.2			13.9	25.1								20.4	20.4	38.8	10 (10)
AS23□1FG-01-06(S)A	6			10.4			16.4	26.2								20.4	38.8	14.2	12 (11)
AS23□1FG-01-08(S)A	8	1/4	17 (17.5)	13.2	12.9	13	16.4	30.1	21.5	40	36.6	35	31.1	29.5	13.3	18 (19)			
AS23□1FG-02-04(S)A	4			8.2			16.5	29.9 (30)								17.5	40.1	20 (21)	
AS23□1FG-02-06(S)A	6			11.2			19	33.8 (33.9)								21.4	43.9	14.2	21 (22)
AS23□1FG-02-08(S)A	8	1/2	24 (23.8)	13.2	17.4	18	19	34.9 (35)	23.5	46	50.8	49.2	43.7	42.1	15.6	23 (23)			
AS23□1FG-02-10(S)A	10			15.9			20.9	38.1 (38.2)								24.7	47.3	15.6	23 (23)
AS23□1FG-02-06(S)A	6			11.2			20.2	36								21.4	57.8	13.3	42 (42)
AS33□1FG-02-08(S)A	8	3/8	19	13.2	12.9	16.6	23	41.2	26.1	54.8	42.3	40.7	44.5	42.9	14.2	43 (43)			
AS33□1FG-02-10(S)A	10			15.9			23	42.5								28.3	57	15.6	46 (46)
AS33□1FG-02-12(S)A	12			18.5			23	42.5								28.3	64.7	17	48 (48)
AS33□1FG-03-06(S)A	6	1/2	24 (23.8)	11.2	12.9	16.6	20.2	36	21.4	50.1	42.3	40.7	37.1	35.5	13.3	32 (33)			
AS33□1FG-03-08(S)A	8			13.2			20.2	37.1								23.5	52.2	14.2	33 (34)
AS33□1FG-03-10(S)A	10			15.9			23	41.2								26.1	54.8	15.6	37 (38)
AS33□1FG-03-12(S)A	12	3/4	30	18.5	17.4	18.8	23	42.5	28.3	57	50.8	49.2	43.7	42.1	17	38 (39)			
AS43□1FG-04-10(S)A	10			15.9			25.6	46.4 (46.3)								26.1	61.2	15.6	58 (57)
AS43□1FG-04-12(S)A	12			18.5			26.2	48.3 (48.2)								28.3	63.4	15.6	62 (61)

Note 1) Reference dimensions Note 2) Reference dimensions of threads after installation Note 3) The values in () are for NPT thread.

Inch Size

Model	d	T	H	D1	D2	D3	L1	L2	L3	L4	L5 Note 1)		A Note 2)		M	Weight [g]			
											Unlocked	Locked	Unlocked	Locked		(g)			
AS23□1FG-01-01(S)A	1/8"	1/8	13 (12.7)	7.2	9.6	12	13.3	24	17.5	36	30.6	29.2	27.5	26.1	13.3	10 (9)			
AS23□1FG-01-03(S)A	5/32"			8.2			13.9	25.1								20.4	20.4	38.8	10 (10)
AS23□1FG-01-07(S)A	1/4"			11.2			16.4	29.1								21.2	38.7	11 (10)	
AS23□1FG-01-09(S)A	5/16"	1/4	17 (17.5)	13.2	12.9	13	16.4	30.1	21.5	40	36.6	35	31.1	29.5	13.3	12 (11)			
AS23□1FG-02-03(S)A	5/32"			8.2			16.5	29.9 (30)								17.5	40.1	18 (19)	
AS23□1FG-02-07(S)A	1/4"			11.2			19	33.8 (33.9)								21.4	43.9	20 (21)	
AS23□1FG-02-09(S)A	5/16"	3/8	19	13.2	12.9	16.6	19	34.9 (35)	23.5	46	50.8	49.2	43.7	42.1	15.6	21 (22)			
AS23□1FG-02-11(S)A	3/8"			15.9			20.9	38.1 (38.2)								24.7	47.3	15.6	23 (23)
AS33□1FG-02-07(S)A	1/4"			11.2			20.2	36								21.4	57.8	13.3	42 (42)
AS33□1FG-02-09(S)A	5/16"	3/4	30	13.2	12.9	16.6	23	41.2	26.1	54.8	42.3	40.7	44.5	42.9	14.2	43 (43)			
AS33□1FG-02-11(S)A	3/8"			15.9			23	41.2								26.1	62.5	15.6	46 (46)
AS33□1FG-03-07(S)A	1/4"			11.2			20.2	36								21.4	50.1	13.3	32 (33)
AS33□1FG-03-09(S)A	5/16"	3/4	30	13.2	12.9	16.6	23	37.1	23.5	52.2	42.3	40.7	37.1	35.5	14.2	33 (34)			
AS33□1FG-03-11(S)A	3/8"			15.9			23	41.2								26.1	54.8	15.6	37 (38)
AS43□1FG-04-11(S)A	3/8"			18.5			25.6	46.4 (46.3)								26.1	61.2	15.6	58 (57)
AS43□1FG-04-13(S)A	1/2"	1/2	24 (23.8)	18.5	17.4	18.8	26.2	48.3 (48.2)	28.3	63.4	50.8	49.2	43.7	42.1	17	61 (60)			
AS43□1FG-04-13(S)A	1/2"			21			26.2	48.3 (48.2)								28.3	63.4	17	62 (61)

Note 1) Reference dimensions Note 2) Reference dimensions of threads after installation Note 3) The values in () are for NPT thread.

AS-FG Series For G thread

Dimensions/ Elbow type

Seal method: Face seal
For G thread

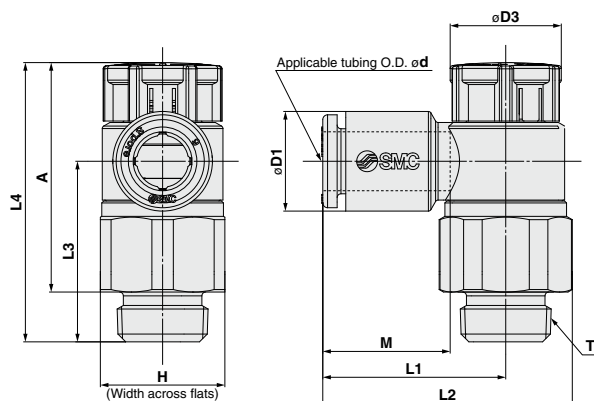

Metric Size

[mm]

Model	d	T	H	D1	D3	L1	L2	L3	L4		A		M	Weight [g]		
									Unlocked	Locked	Unlocked	Locked				
AS22□1FG-G01-23A	3.2	1/8	13	7.2	12	19.1	26.2	18.8	30.3	28.9	24.8	23.4	13.3	10		
AS22□1FG-G01-04A	4			8.2												
AS22□1FG-G01-06A	6			10.4												
AS22□1FG-G01-08A	8			13.2											22.4	29.5
AS22□1FG-G01-10A	10	15.9	25.3	32.4									14.2	11		
AS22□1FG-G02-23A	3.2	1/4	17	7.2	13	23.4	32.7	22.6	36.6	35	30.1	28.5	13.3	20		
AS22□1FG-G02-04A	4			8.2											20.9	30.2
AS22□1FG-G02-06A	6			10.4											23.4	32.7
AS22□1FG-G02-08A	8			13.2											23.9	33.2
AS22□1FG-G02-10A	10	15.9	26.9	36.2									15.6	22		
AS32□1FG-G02-06A	6	1/4	21	10.4	16.6	21.8	33	36.4	50	48.4	43.5	41.9	13.3	50		
AS32□1FG-G02-08A	8			13.2		22.7	33.9						14.2			
AS32□1FG-G02-10A	10			15.9		26.7	37.9						35.7		15.6	52
AS32□1FG-G02-12A	12			18.5		29.7	40.9						34.5		17	53
AS32□1FG-G03-06A	6	3/8	21	10.4	16.6	21.8	33	28.7	42.3	40.7	34.8	33.2	13.3	37		
AS32□1FG-G03-08A	8			13.2		22.7	33.9						14.2		38	
AS32□1FG-G03-10A	10			15.9		26.7	37.9						28		15.6	39
AS32□1FG-G03-12A	12			18.5		29.7	40.9						26.8		17	41
AS42□1FG-G04-10A	10	1/2	27	15.9	18.8	27.4	41.8	36.2	50.8	49.2	41.8	40.2	15.6	69		
AS42□1FG-G04-12A	12			18.5		30.8	45.2	35.1					17		71	
AS42□1FG-G04-16A	16			23.8		34.8	49.2	32.7					20.6		75	

Dimensions/ Universal type

Seal method: Face seal
For G thread

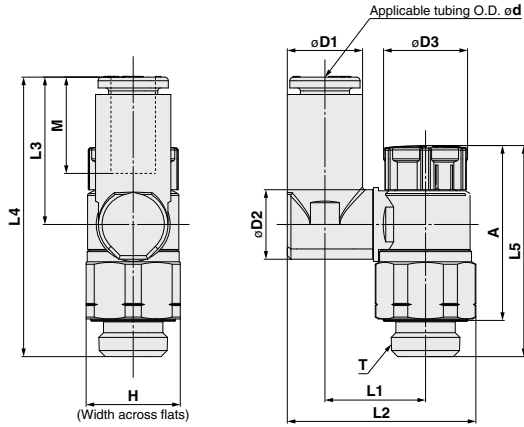
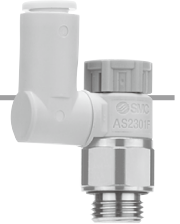

Metric Size

Model	d	T	H	D1	D2	D3	L1	L2	L3	L4	L5		A		M	Weight [g]
											Unlocked	Locked	Unlocked	Locked		
AS23□1FG-G01-23A	3.2	1/8	13	7.2	9.6	12	13.3	24.0	17.5	35.7	30.3	28.9	24.8	23.4	13.3	10
AS23□1FG-G01-04A	4			8.2			13.9	25.1								10
AS23□1FG-G01-06A	6			10.4	16.4		26.2	20.4	11							
AS23□1FG-G01-08A	8	1/4	17	13.2	10.2	13	16.4	30.1	21.5	39.7	36.6	35	30.1	28.5	14.2	12
AS23□1FG-G02-04A	4			8.2	16.5		29.9	17.5	40.1	21						
AS23□1FG-G02-06A	6			10.4	19		33.8	21.4	43.9	13.3						
AS23□1FG-G02-08A	8	13.2	20.9	34.9	23.5	46.0	14.2	24								
AS23□1FG-G02-10A	10	15.9	20.9	38.1	24.7	47.3	15.6	25								
AS33□1FG-G02-06A	6	1/4	21	10.4	12.9	16.6	20.2	36.6	21.4	57.8	50	48.4	43.5	41.9	13.3	51
AS33□1FG-G02-08A	8			13.2			38.0	23.5	59.9	14.2					52	
AS33□1FG-G02-10A	10			15.9	42.2		26.1	58.0	15.6	55						
AS33□1FG-G02-12A	12	18.5	23	43.5	28.3	59.9	17	57								
AS33□1FG-G03-06A	6	3/8	21	10.4	12.9	16.6	20.2	36.6	21.4	50.1	42.3	40.7	34.8	33.2	13.3	40
AS33□1FG-G03-08A	8			13.2			38.0	23.5	52.2	14.2					41	
AS33□1FG-G03-10A	10			15.9	42.2		26.1	50.3	15.6	44						
AS33□1FG-G03-12A	12	18.5	23	43.5	28.3	52.2	17	46								
AS43□1FG-G04-10A	10	1/2	27	15.9	17.4	18.8	25.6	47.9	26.1	61.2	50.8	49.2	41.8	40.2	15.6	75
AS43□1FG-G04-12A	12			18.5	21		26.2	49.8	28.3	63.4					17	79

- AS-F
- TMH
- ASD
- AS
- AS-FE
- KE
- AS-FG
- AS-FP
- AS-FM
- AS-D
- AS-T
- ASP
- ASN
- AQ
- ASV
- AK
- VCHC
- ASR
- ASQ

AS-FG Series

Made to Order

Please contact SMC for detailed dimensions, specifications and lead times.

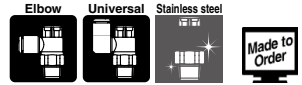

1 Lubricant: Vaseline

-X12

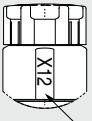

Laser printing

Example) AS2201FG-01-04SA-X12

2 Grease-free (Seal: Fluorine-coated) + Restrictor (Without check valve)

-X21

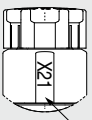

Laser printing

Example) AS2201FG-01-04SA-X21

Note 1) Not particle-free

Note 2) This product is a restrictor without a check valve (no control direction). Be aware that all part numbers are for a meter-out type; there is no part number for a meter-in type.

3 Restrictor (Without check valve)

-X214

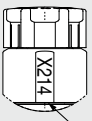

Laser printing

Example) AS2201FG-01-04SA-X214

Note) This product is a restrictor without a check valve (no control direction). Be aware that all part numbers are for a meter-out type; there is no part number for a meter-in type.

4 Clean Series

10-

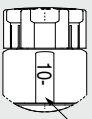

Laser printing

Example) 10-AS2201FG-01-04SA

Note 1) Fluorine grease is used.

Note 2) The cleanliness class (ISO class) is 5.

Note 3) Excluding G thread type.