

# Multi-connector DM Series

RoHS

The use of the multiconnector enables panel mount connections with other apparatus and can provide the reliability of one-touch installation and removal of multi-tubes (nylon, polyurethane). As a result, separate transportation of panel, machinery, and backup units is made easy.

## One-touch installation and removal

Employs the unique built-in keying mechanism which provides one-touch installation and removal capability even in hard to see locations. In addition, it prevents installation mistakes when re-connecting.

## Installation processes are reduced considerably

As compared with the use of many bulkhead unions, this installation is very easy and installation time is reduced considerably.

## Reliable tube retaining force

This construction mechanism enables clamping and unclamping of every tube in use by one operation and can provide a reliable tube retaining force.

## No. of connecting tubes

2 types—6 tubes & 12 tubes.

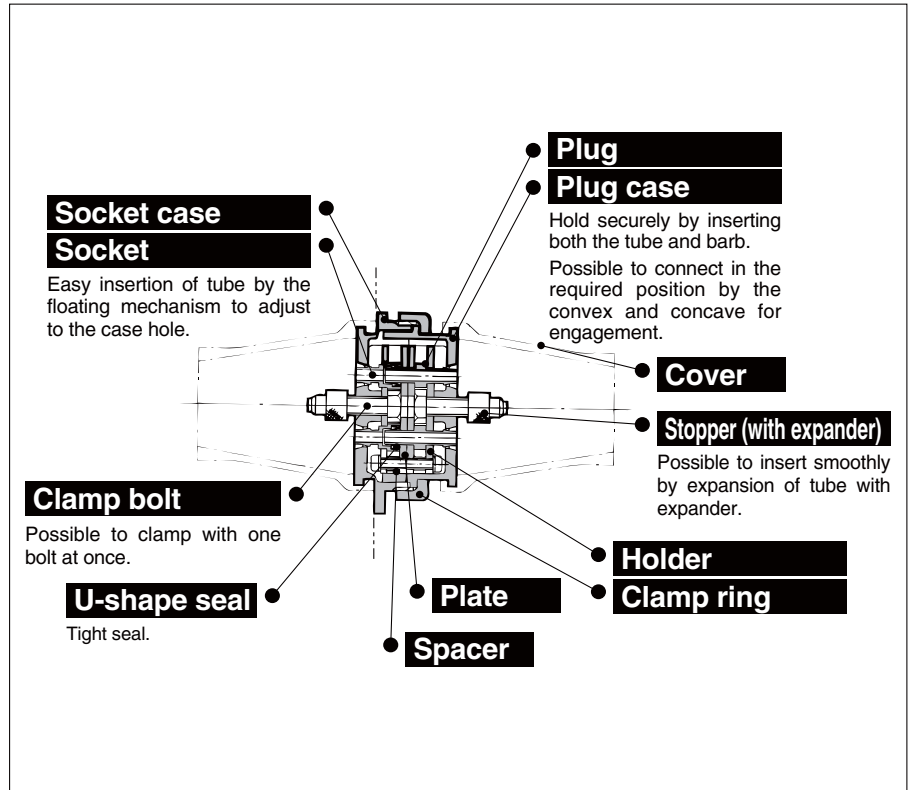
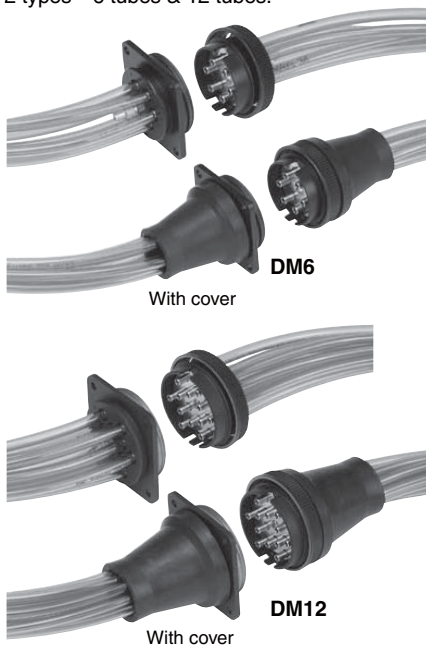

## Model

No. of connecting tubes	Model			Applicable tubing			Replacement parts no.	
	Multi-connector	Plug side	Socket side	Nylon	Soft nylon	Polyurethane	Cover	Clamp ring
6	DM6-04N	DM6P-04N	DM6S-04N	T0425	—	—	DM-C-6	DM6-P01
	DM6-04NU	DM6P-04NU	DM6S-04NU	T0403	TS0425	TU0425		
	DM6-06N	DM6P-06N	DM6S-06N	T0604	—	—		
	DM6-06NU	DM6P-06NU	DM6S-06NU	T0645	TS0604	TU0604		
12	DM12-04N	DM12P-04N	DM12S-04N	T0425	—	—	DM-C-12	DM12-P01
	DM12-04NU	DM12P-04NU	DM12S-04NU	T0403	TS0425	TU0425		
	DM12-06N	DM12P-06N	DM12S-06N	T0604	—	—		
	DM12-06NU	DM12P-06NU	DM12S-06NU	T0645	TS0604	TU0604		

## Specifications

Fluid	Air
Operating pressure range	0 to 1 MPa
Ambient and fluid temperature	-5 to 60°C (No freezing)

## Principal Parts Material

Socket case, Plug case, Clamp ring	ADC12, Black semi-gloss baking finish after chromated
Plate	SPCC, Chromated
Holder	SPCC, Zinc chromated
Socket, Plug, Stopper	C3604
U packing	NBR
Cover	CR
Cross-recessed head machine screw, Clamp bolt	SWRM Zinc chromated
Spacer	SPC Zinc chromated

**How to Use**

**⚠ Caution**

**Removing**

Loosen clamp ring (1), and separate the multiconnector into two parts, multiconnector into two parts, socket side and plug side.

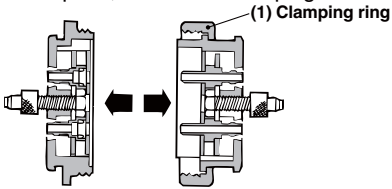

**Insertion and removal of tube**

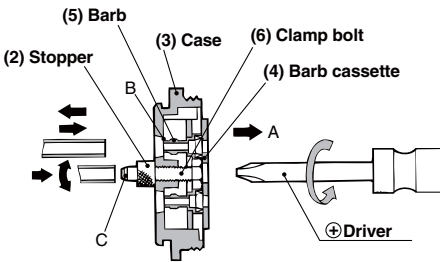

1. Turn the clamp bolt (6) to the left with a screwdriver, loosen until the stopper (2) touches the case (3), and barb cassette (4) will be pulled out in the direction A. Then clamp portion B, consisting of barb (5) and case (3), will be freed. Next, insert or remove the tube.
2. The corresponding numbers are stamped on both the socket and plug sides for each tube connection.
3. If it is hard to insert the tube, enlarge the tube end with the head of stopper (2), expander C, before inserting tube.
4. Insert tube until it clears mounting of barb (5) completely.

**Clamping of tube**

1. After inserting tube, tighten clamp bolt (6) clockwise with a screwdriver.
2. Barb cassette creeps into the direction D and the tube will be clamped at the B clamp portion (5) consisting of barb (3) and case.

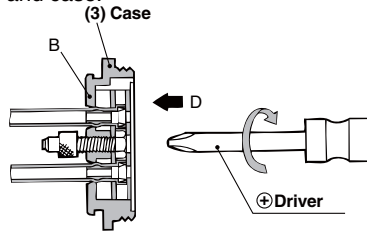

**Connection**

1. Push together and rotate both of the cases, and the plug side will slide into the socket side at the proper position.
2. The ring E, male and female, of the plug side and socket side will interlock with each other at the proper position by pushing together and rotating.
3. Final process of connection is to screw-in the clamp ring.

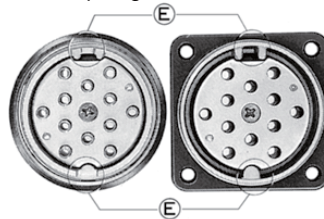

**Cover mounting**

1. Cover is mountable on both sides, plug side and socket side.
2. Enlarge cover and mount cover onto mounting area.

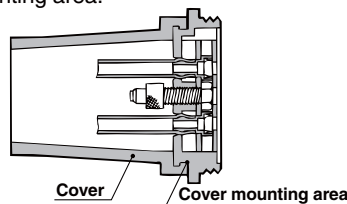

**How to Order**

**DM 6 - 04 N -**

**Number of connecting tubes**

6	6
12	12

**Type**

Nil	Multi-connector
P	Plug side
S	Socket side

**Accessory (Option)**

C1	1 cover (Single side)
C2	2 covers (Both sides)

**Tube material**

N	Nylon
NU	Soft nylon Polyurethane

**Tubing O.D.**

04	4 mm
06	6 mm

KQ2

KQB2

KS  
KX

KM

KF

M

H/DL  
L/LL

KC

KK

KK130

**DM**

KDM

KB

KR

KA

KQG2

KG

KFG2

MS

KKA

KP

LQ

MQR

T

IDK

# DM Series

## Dimensions: DM6/12

### DM6

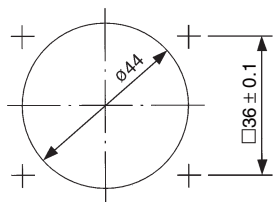

Panel mounting hole  
(with the cover at socket side)

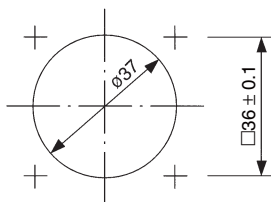

Panel mounting hole

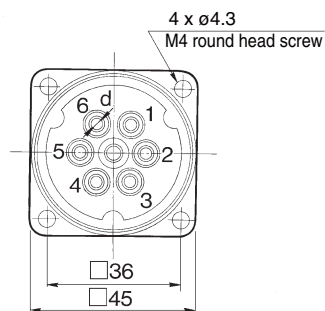
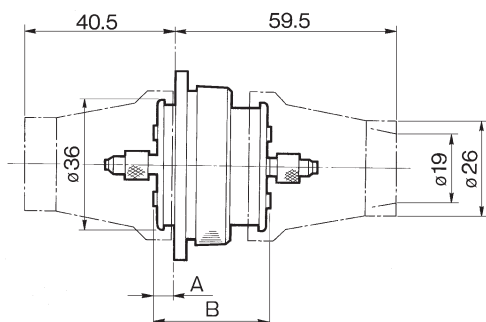

### DM12

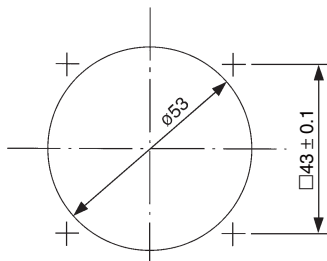

Panel mounting hole  
(with the cover at socket side)

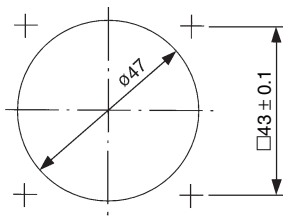

Panel mounting hole

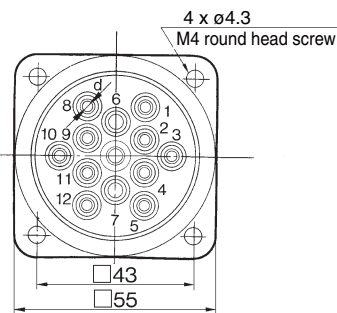
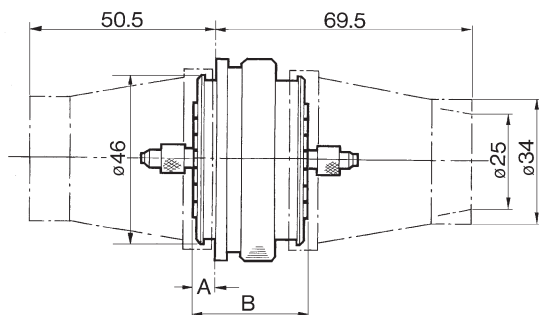

Mode		Barb I.D. (d)	A	B
DM6-04N	DM12-04N	1.6	5	31
DM6-06N	DM12-06N	3		
DM6-04NU	DM12-04NU	1.6	6	31
DM6-06NU	DM12-06NU	3		