

# Prior to Use

## Auto Switches Common Specifications 1

Refer to the Auto Switch Precautions on pages 8 to 12 before using auto switches.

### Auto Switches Common Specifications

| Type                  | Reed auto switch  | Solid state auto switch                               |
|-----------------------|---|---|
| Leakage current       | None  | 3-wire: 100 $\mu$ A or less, 2-wire: 0.8 mA or less   |
| Operating time        | 1.2 ms  | 1ms or less *3)                                       |
| Impact resistance     | 300 m/s <sup>2</sup>  | 1000 m/s <sup>2</sup> *4)                             |
| Insulation resistance | 50 M $\Omega$ or more (500 VDC measured via megohmmeter) (Between lead wire and case) |   |
| Withstand voltage     | 1500 VAC for 1 minute *1)<br>(Between lead wire and case)                             | 1000 VAC for 1 minute<br>(Between lead wire and case) |
| Ambient temperature   | -10 to 60°C   |   |
| Enclosure             | IEC60529 Standard IP67 *2)  |   |

- \* 1) Electrical entry: Connector type (A73C/A80C/C73C/C80C): 1000 VAC/min. (Between lead wire and the case)
- \* 2) The terminal conduit type (D-A3/A3□/A3□C/G39/G39A/G39C/K39/K39A/K39C), DIN terminal type (D-A44/A44A/A44C) and heat resistant auto switch (D-F7NJ) conform to IEC60529 Standard IP63.  
The trimmer type amplifier section (D-R□K) conforms to IP40.  
The enclosure IP rating does not include the switch lead wire end.  
For switches with a connector, the enclosure IP requirements are satisfied when the connector is connected.
- \* 3) Excluding the solid state auto switches with a timer (G5NT/F7NT/F5NT types) and magnetic field resistant 2-color indicator solid state auto switch (D-P3DW□/P4DW).  
The operating time for D-J51 is 2 ms or less and for D-P3DW□/P4DW are 40 ms or less.
- \* 4) 980 m/s<sup>2</sup> for the trimmer type sensor section, 98 m/s<sup>2</sup> for the amplifier section.

### Lead Wire

#### Lead wire length indication

(Example)

D-M9BW L

Auto switch model

Lead wire length

| Symbol | Length | Tolerance    | Connector specifications                        | Solid state | Reed  |
|--------|--------|--------------|---|-------------|-------|
| Nll    | 0.5 m  | $\pm$ 15 mm  | /   | ●           | ●     |
| M      | 1 m    | $\pm$ 30 mm  |   | ● *2)       | ● *2) |
| L      | 3 m    | $\pm$ 90 mm  |   | ●           | ●     |
| Z      | 5 m    | $\pm$ 150 mm |   | ●           | ● *3) |
| N *1)  | None   | —            |   | ●           | ●     |
| SAPC   | 0.5 m  | $\pm$ 15 mm  | M8-3 pin  | ○           | —     |
| MAPC   | 1 m    | $\pm$ 30 mm  | Plug connector                                  | ○           | —     |
| SBPC   | 0.5 m  | $\pm$ 15 mm  | M8-4 pin  | ○           | —     |
| MBPC   | 1 m    | $\pm$ 30 mm  | Plug connector                                  | ○           | —     |
| SDPC   | 0.5 m  | $\pm$ 15 mm  | M12-4 pin A code (Normal key)<br>Plug connector | ○           | —     |
| MDPC   | 1 m    | $\pm$ 30 mm  |   | ○           | —     |
| LDPC   | 3 m    | $\pm$ 90 mm  |   | ○           | —     |

●: Standard ○: Produced upon receipt of order (Standard)

- \* 1) Applicable to the connector type (D-□□C) only.
- \* 2) Applicable to the D-M9□ (V), D-M9□V (V), D-M9□A (V), and D-A93 only.
- \* 3) Applicable to the D-B53/B54, D-C73(C)/C80C, D-A93(V), D-A73(C)/A80C, D-A53/A54, D-Z73, and D-90/97/90A/93A only.
- \* 4) For reed auto switches M8 and M12 type with connector, please contact SMC.
- \* 5) The standard lead wire length of the trimmer auto switch is 3 m.
- \* 6) The standard lead wire length of the solid state auto switch with the timer except for the D-P3DW and D-M9□A (V)□, water-resistant 2-color display solid state auto switch, wide range detection auto switch, heat resistant 2-color display solid state auto switch, and strong magnetic field resistant 2-color display solid state auto switch is 3 m or 5 m. (Product with a lead wire length of 0.5 m is not available.)

#### Lead wires with a connector indication

##### Part No. of Lead Wires with Connectors

(Applicable only for connector type)

| Model  | Lead wire length |
|--------|------------------|
| D-LC05 | 0.5 m            |
| D-LC30 | 3 m              |
| D-LC50 | 5 m              |

# Prior to Use

## Auto Switches Common Specifications 2

Refer to the Auto Switch Precautions on pages 8 to 12 before using auto switches.

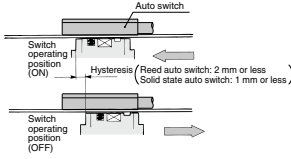
| Term  | Meaning   |
|---|---|
| <b>Hysteresis</b>                           |  <p>A deviation amount between the ON position and OFF position caused by auto switch characteristics (difference in sensitivity between ON and OFF). When the switch is turned ON once and the switch (or piston) is moved in the opposite direction, a symptom occurs that the position where the switch turns OFF deviates to a position where it is further returned from the ON position. This deviation amount is called "hysteresis".</p> <p>Note) Hysteresis may fluctuate due to the operating environment. Please contact SMC if hysteresis causes an operational problem.</p>   |
| <b>Most sensitive position</b>              | A position (sensor layout position) where the sensitivity is highest on the detection surface of the auto switch enclosure. When the center of the magnet is aligned with this position, this becomes almost the center of the operating range and stable operation can be obtained.  |
| <b>Programmable Logic Controller (PLC)</b>  | One of elements making up the sequence control. The PLC is so designed that it receives signals, such as auto switch output and outputs them to other devices so as to perform the electrical control according to the preset program.  |
| <b>Ambient temperature</b>                  | A temperature range, in which the auto switch can be used. If significant temperature change or freezing occurs even in this temperature range, this may cause the auto switch to malfunction.  |
| <b>Operating voltage</b>                    | A voltage, at which the auto switch can be used. The operating voltage is indicated using generally used voltage (24 VDC or 100 VAC, etc.). For 2-wire type, the operating voltage has the same meaning as the power supply voltage or load voltage.  |
| <b>Operating current range</b>              | A range of the current value that can be flowed to the output of the auto switch. If the operating current is lower than this range, the auto switch does not operate correctly. Conversely, if the operating current is higher than this range, this may cause the auto switch to break.   |
| <b>Current consumption</b>                  | This current value is necessary for the 3-wire type auto switch to operate the circuit through the power cable. For 2-wire type, as the current consumption is a part of the load current, it is not defined.   |
| <b>Insulation resistance</b>                | A resistance between the electric circuit and enclosure. Unless otherwise described particularly, 50 M $\Omega$ (Min) is used for auto switch.  |
| <b>Magnetic field resistant auto switch</b> | An auto switch, for which measures against effects arising from external (welding) magnetic field generated in the spot welding process, etc. are taken. The solid state auto switch functions as it detects the frequency of the applied magnetic field. If the external magnetic field (AC) is applied, the last signal is retained not to be affected by the external magnetic field. This system can be used by the cylinder with normal magnetic force. The reed auto switch built-in a magnetic field shielded sensor with a low sensitivity to make the effect of the external magnetic field (DC or AC magnetic field) insusceptible. Therefore, a dedicated cylinder built-in the strong magnet needs to be selected and there is also an operable range (conditions). |
| <b>Impact resistance value</b>              | A minimum acceleration that may cause the auto switch to malfunction or break when the standard impact is applied.  |
| <b>Water-resistant type auto switch</b>     | A model, long-term water resistance of which is improved by taking structural measures for the general (general purpose) product.   |
| <b>Withstand voltage</b>                    | A tolerance dose when the voltage is applied to the portion between the electrical circuit and enclosure. The withstand voltage shows a strength level of the product against the voltage. If a voltage exceeding the withstand voltage is applied, this may cause the product to break. (The voltage described here is different from the power supply voltage necessary to operate the product.)  |
| <b>Proper mounting position</b>             | A dimension that shows the mounting position when the position is detected at the stroke end of the cylinder. As this position is set, the maximum sensitivity position is aligned with the center of the magnet. However, make the adjustment with the actual machine by considering the characteristic difference during actual setting. When an adjustment allowance is needed for the detection before the stroke, set a value with an adjustment allowance added to the proper mounting position.  |
| <b>Applicable load</b>                      | A device that is assumed as a target load of the auto switch.   |
| <b>Operating time</b>                       | A period of time until the auto switch output becomes stable after the magnetic force to operate the auto switch has been received.   |
| <b>Operating range</b>                      | An auto switch operating range in response to the cylinder piston movement (ON length in response to the stroke). The operating range is determined by the magnetic force of the magnet (range, in which the magnetic force acts) and switch sensitivity. So, the operating range may vary as these conditions are changed by the ambient environment, etc. The operating range in the standard status (normal temperature, single cylinder, magnetic force, and sensitivity, etc.) is described in the catalog.  |

D-□

# Prior to Use

## Auto Switches Common Specifications 3

Refer to the Auto Switch Precautions on pages 8 to 12 before using auto switches.

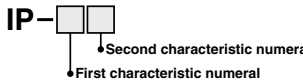
| Term   | Meaning  |   |               |   |  |   |  |   |   |   |   |   |                |   |           |   |               |   |  |   |  |   |  |   |                                   |   |                              |   |                                       |   |   |   |  |
|--|--|---|---------------|---|--|---|--|---|---|---|---|---|----------------|---|-----------|---|---------------|---|--|---|--|---|--|---|-----------------------------------|---|------------------------------|---|---------------------------------------|---|---|---|--|
| <b>Minimum Stroke for Auto Switch Mounting</b> | A minimum stroke value of the auto switch that can be mounted on the cylinder.<br>The minimum stroke is determined by the specification limit (auto switch operation or position setting ability, etc.) and physical limit (mechanical interference associated with the auto switch mounting).<br>Note that the catalog shows the value assuming that the position detection is performed at the stroke end and this value does not consider the adjustment allowance.<br>When an adjustment allowance is needed, such as detection before the stroke, a value is set that this adjustment allowance is added to the minimum stroke.   |   |               |   |  |   |  |   |   |   |   |   |                |   |           |   |               |   |  |   |  |   |  |   |                                   |   |                              |   |                                       |   |   |   |  |
| <b>Internal voltage drop</b>                   | A voltage that is applied to the portion between the COM and signal line when the auto switch is ON.<br>As only a value that the internal voltage drop is subtracted from the power supply voltage is applied to the input side of the PLC, the detection fault (incorrect input) may occur if this value is lower than the minimum operating voltage. So, take great care when selecting a device.  |   |               |   |  |   |  |   |   |   |   |   |                |   |           |   |               |   |  |   |  |   |  |   |                                   |   |                              |   |                                       |   |   |   |  |
| <b>2-Color Indicator</b>                       | As the end part of the auto switch operating range (boundary between ON and OFF) is an area where is susceptible to the external disturbance or stroke change during cylinder operation, this function is intended to quickly and properly make the setting at the center of the operating range where the stable operation can be obtained by changing the operation indication color of the auto switch.   |   |               |   |  |   |  |   |   |   |   |   |                |   |           |   |               |   |  |   |  |   |  |   |                                   |   |                              |   |                                       |   |   |   |  |
| <b>Load</b>                                    | A device that is connected to the output of the auto switch so as to do any work is called "load".<br>For example, the load is a relay or PLC, etc.<br>To check the operation of the auto switch, a device equivalent to the load (such as resistor, etc.) is connected.   |   |               |   |  |   |  |   |   |   |   |   |                |   |           |   |               |   |  |   |  |   |  |   |                                   |   |                              |   |                                       |   |   |   |  |
| <b>Load current</b>                            | A current that flows to the load when the ON-OFF output is ON.   |   |               |   |  |   |  |   |   |   |   |   |                |   |           |   |               |   |  |   |  |   |  |   |                                   |   |                              |   |                                       |   |   |   |  |
| <b>Enclosure</b>                               | A class of protection against solid or water entry of the electrical machinery and apparatus specified in IEC60529.<br> <p>●<b>First Characteristics:</b><br/><b>Degrees of protection against solid foreign objects</b></p> <table border="1"> <tbody> <tr><td>0</td><td>Non-protected</td></tr> <tr><td>1</td><td>Protected against solid foreign objects of 50 mm ø and greater</td></tr> <tr><td>2</td><td>Protected against solid foreign objects of 12 mm ø and greater</td></tr> <tr><td>3</td><td>Protected against solid foreign objects of 2.5 mm ø and greater</td></tr> <tr><td>4</td><td>Protected against solid foreign objects of 1.0 mm ø and greater</td></tr> <tr><td>5</td><td>Dust-protected</td></tr> <tr><td>6</td><td>Dusttight</td></tr> </tbody> </table> <p>●<b>Second Characteristics:</b><br/><b>Degrees of protection against water</b></p> <table border="1"> <tbody> <tr><td>0</td><td>Non-protected</td></tr> <tr><td>1</td><td>Protected against vertically falling water drops</td></tr> <tr><td>2</td><td>Protected against vertically falling water drops when enclosure tilted up to 15°</td></tr> <tr><td>3</td><td>Protected against rainfall when enclosure tilted up to 60°</td></tr> <tr><td>4</td><td>Protected against splashing water</td></tr> <tr><td>5</td><td>Protected against water jets</td></tr> <tr><td>6</td><td>Protected against powerful water jets</td></tr> <tr><td>7</td><td>Protected against the effects of temporary immersion in water</td></tr> <tr><td>8</td><td>Protected against the effects of continuous immersion in water</td></tr> </tbody> </table> <p>Example) In the case of stipulated as IP65, we can know the degrees of protection is dusttight and water jet-proof on the grounds that the first characteristic numeral is 6 and the second characteristic numeral is 5 respectively, that gives it will not be adversely affected by direct water jets from any direction.</p> | 0 | Non-protected | 1 | Protected against solid foreign objects of 50 mm ø and greater | 2 | Protected against solid foreign objects of 12 mm ø and greater | 3 | Protected against solid foreign objects of 2.5 mm ø and greater | 4 | Protected against solid foreign objects of 1.0 mm ø and greater | 5 | Dust-protected | 6 | Dusttight | 0 | Non-protected | 1 | Protected against vertically falling water drops | 2 | Protected against vertically falling water drops when enclosure tilted up to 15° | 3 | Protected against rainfall when enclosure tilted up to 60° | 4 | Protected against splashing water | 5 | Protected against water jets | 6 | Protected against powerful water jets | 7 | Protected against the effects of temporary immersion in water | 8 | Protected against the effects of continuous immersion in water |
| 0  | Non-protected  |   |               |   |  |   |  |   |   |   |   |   |                |   |           |   |               |   |  |   |  |   |  |   |                                   |   |                              |   |                                       |   |   |   |  |
| 1  | Protected against solid foreign objects of 50 mm ø and greater   |   |               |   |  |   |  |   |   |   |   |   |                |   |           |   |               |   |  |   |  |   |  |   |                                   |   |                              |   |                                       |   |   |   |  |
| 2  | Protected against solid foreign objects of 12 mm ø and greater   |   |               |   |  |   |  |   |   |   |   |   |                |   |           |   |               |   |  |   |  |   |  |   |                                   |   |                              |   |                                       |   |   |   |  |
| 3  | Protected against solid foreign objects of 2.5 mm ø and greater  |   |               |   |  |   |  |   |   |   |   |   |                |   |           |   |               |   |  |   |  |   |  |   |                                   |   |                              |   |                                       |   |   |   |  |
| 4  | Protected against solid foreign objects of 1.0 mm ø and greater  |   |               |   |  |   |  |   |   |   |   |   |                |   |           |   |               |   |  |   |  |   |  |   |                                   |   |                              |   |                                       |   |   |   |  |
| 5  | Dust-protected   |   |               |   |  |   |  |   |   |   |   |   |                |   |           |   |               |   |  |   |  |   |  |   |                                   |   |                              |   |                                       |   |   |   |  |
| 6  | Dusttight  |   |               |   |  |   |  |   |   |   |   |   |                |   |           |   |               |   |  |   |  |   |  |   |                                   |   |                              |   |                                       |   |   |   |  |
| 0  | Non-protected  |   |               |   |  |   |  |   |   |   |   |   |                |   |           |   |               |   |  |   |  |   |  |   |                                   |   |                              |   |                                       |   |   |   |  |
| 1  | Protected against vertically falling water drops   |   |               |   |  |   |  |   |   |   |   |   |                |   |           |   |               |   |  |   |  |   |  |   |                                   |   |                              |   |                                       |   |   |   |  |
| 2  | Protected against vertically falling water drops when enclosure tilted up to 15°   |   |               |   |  |   |  |   |   |   |   |   |                |   |           |   |               |   |  |   |  |   |  |   |                                   |   |                              |   |                                       |   |   |   |  |
| 3  | Protected against rainfall when enclosure tilted up to 60°   |   |               |   |  |   |  |   |   |   |   |   |                |   |           |   |               |   |  |   |  |   |  |   |                                   |   |                              |   |                                       |   |   |   |  |
| 4  | Protected against splashing water  |   |               |   |  |   |  |   |   |   |   |   |                |   |           |   |               |   |  |   |  |   |  |   |                                   |   |                              |   |                                       |   |   |   |  |
| 5  | Protected against water jets   |   |               |   |  |   |  |   |   |   |   |   |                |   |           |   |               |   |  |   |  |   |  |   |                                   |   |                              |   |                                       |   |   |   |  |
| 6  | Protected against powerful water jets  |   |               |   |  |   |  |   |   |   |   |   |                |   |           |   |               |   |  |   |  |   |  |   |                                   |   |                              |   |                                       |   |   |   |  |
| 7  | Protected against the effects of temporary immersion in water  |   |               |   |  |   |  |   |   |   |   |   |                |   |           |   |               |   |  |   |  |   |  |   |                                   |   |                              |   |                                       |   |   |   |  |
| 8  | Protected against the effects of continuous immersion in water   |   |               |   |  |   |  |   |   |   |   |   |                |   |           |   |               |   |  |   |  |   |  |   |                                   |   |                              |   |                                       |   |   |   |  |
| <b>Solid state auto switch</b>                 | A switch that detects the magnetic field by the MR element and incorporates the judgement circuit to turn ON or OFF the output regardless of the contact or non-contact of the mechanical contact like transistor (non-contact part).  |   |               |   |  |   |  |   |   |   |   |   |                |   |           |   |               |   |  |   |  |   |  |   |                                   |   |                              |   |                                       |   |   |   |  |
| <b>Leak current</b>                            | A current that flows to operate the internal circuit when the ON-OFF output is OFF. In particular, if this leak current exceeds the detection current in the 2-wire type auto switch or PLC, this may cause reset fault. So, take great care when selecting a device.  |   |               |   |  |   |  |   |   |   |   |   |                |   |           |   |               |   |  |   |  |   |  |   |                                   |   |                              |   |                                       |   |   |   |  |
| <b>Reed auto switch</b>                        | A switch that uses the reed switch to detect the magnetic field and turn ON or OFF the output by the contact or non-contact of the mechanical contact (contact part is provided like relay or limit switch).   |   |               |   |  |   |  |   |   |   |   |   |                |   |           |   |               |   |  |   |  |   |  |   |                                   |   |                              |   |                                       |   |   |   |  |
| <b>Induction load</b>                          | A load that has the coil. The connection target of the auto switch is a relay.   |   |               |   |  |   |  |   |   |   |   |   |                |   |           |   |               |   |  |   |  |   |  |   |                                   |   |                              |   |                                       |   |   |   |  |
| <b>Recommended lead wire bending radius</b>    | A minimum bending radius (reference value) of the lead wire when the lead wire is secured and constructed (oscillation or rotation is not considered).<br>(As the temperature or current value conforms to the auto switch specifications, this lead wire bending radius differs from the value disclosed by the electric wire manufacturer.)  |   |               |   |  |   |  |   |   |   |   |   |                |   |           |   |               |   |  |   |  |   |  |   |                                   |   |                              |   |                                       |   |   |   |  |
| <b>Electrical entry</b>                        | A structure, in which the lead wire of the auto switch is taken out in the horizontal direction when the cylinder is laid out horizontally (cylinder rod is horizontal), is called "in-line entry". A structure, in which the lead wire is taken out in a direction perpendicular to the cylinder axis center, is called "perpendicular entry".  |   |               |   |  |   |  |   |   |   |   |   |                |   |           |   |               |   |  |   |  |   |  |   |                                   |   |                              |   |                                       |   |   |   |  |

# Prior to Use

## Auto Switches/Internal Circuit

### Solid State Auto Switches

**Solid state 3-wire, NPN**

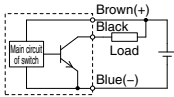

**Solid state 3-wire, PNP**

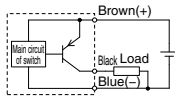

**Solid state 2-wire**

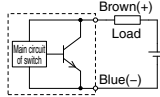

**Solid state 2-wire, Non-polar type**

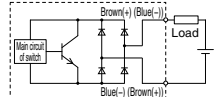

(Power supply for switch and load are separate)

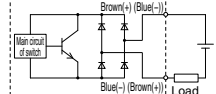
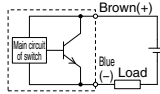
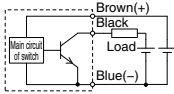

### Reed Auto Switches

| No.             | ①                                       | ②                                  | ③                                  | ④                                  |
|-----------------|---|------------------------------------|------------------------------------|------------------------------------|
| Circuit diagram | <p><b>2-wire (Reed switch)</b></p>      | <p><b>2-wire (Reed switch)</b></p> | <p><b>2-wire (Reed switch)</b></p> | <p><b>2-wire (Reed switch)</b></p> |
| No.             | ⑤                                       | ⑥                                  | ⑦                                  |                                    |
| Circuit diagram | <p><b>3-wire (Reed switch, NPN)</b></p> | <p><b>2-wire (Reed switch)</b></p> | <p><b>2-wire (Reed switch)</b></p> |                                    |

### Contact Protection Box/CD-P11, CD-P12

<Applicable switch models>

D-A7/A8, D-A7□H/A80H, D-A73C, A80C, D-C7/C8, D-C73C/C80C, D-E7□A, E80A, D-Z7/Z8, D-9/9□A, D-A9/A9□V, D-A79W

The auto switches above do not have a built-in contact protection circuit.

A contact protection box is not required for solid state auto switches due to their construction.

1. Where the operation load is an inductive load.
2. Where the wiring length to load is greater than 5 m.
3. Where the load voltage is 100/200 VAC.

Therefore, use a contact protection box with the switch for any of the above cases:

The contact life may be shortened (due to permanent energizing conditions). **D-A72(H) must be used with the contact protection box regardless of load types and lead wire length since it is greatly affected by loads. (Where the load voltage is 110 VAC)**

When the load voltage is increased by more than 10% to the rating of applicable auto switches (except D-A73C/A80C/C73C/C80C/90/97/A79W) above, use a contact protection box (CD-P11) to reduce the upper limit of the load current by 10% so that it can be set within the range of the load current range, 110 VAC.

Even for the built-in contact protection circuit type (D-A34[A][C], DA44[A][C], D-A54/A64, D-A59W, D-B59W), **use the contact protection box when the wiring length to load is very long (over 30 m) and PLC (Programmable Logic Controller) with a large inrush current is used.**

### Contact Protection Box Specifications

| Part no.          | CD-P11          | CD-P12         |
|-------------------|-----------------|----------------|
| Load voltage      | 100 VAC or less | 200 VAC 24 VDC |
| Max. load current | 25 mA           | 12.5 mA 50 mA  |

※Lead wire length — Auto switch connection side 0.5 m  
Load connection side 0.5 m



### Contact Protection Box Internal Circuit

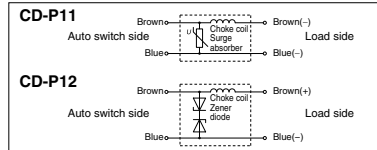

### Contact Protection Box/Dimensions

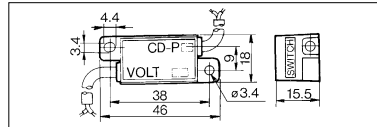

### Contact Protection Box Connection

To connect a switch unit to a contact protection box, connect the lead wire from the side of the contact protection box marked SWITCH to the lead wire coming out of the switch unit. Keep the switch as close as possible to the contact protection box, with a lead wire length of no more than 1 meter.

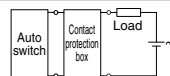

# Prior to Use

## Auto Switch Connection and Example

### Sink Input Specifications

#### 3-wire, NPN

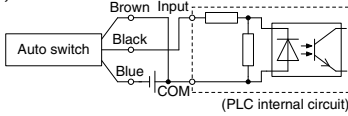

#### 2-wire

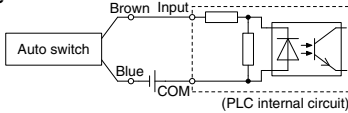

### Source Input Specifications

#### 3-wire, PNP

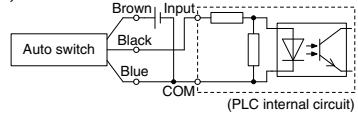

#### 2-wire

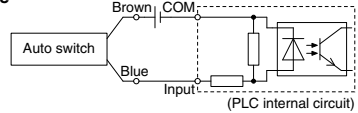

Connect according to the applicable PLC input specifications, as the connection method will vary depending on the PLC input specifications.

### Example of AND (Series) and OR (Parallel) Connection

\* When using solid state auto switches, ensure the application is set up so the signals for the first 50 ms are invalid. Depending on the operating environment, the product may not operate properly.

#### 3-wire AND connection for NPN output (Using relays)

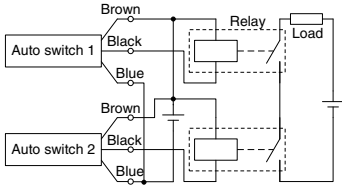

#### (Performed with auto switches only)

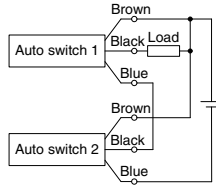

#### 3-wire OR connection for NPN output

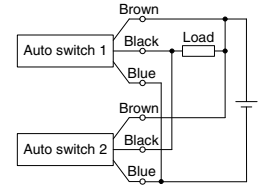

#### 3-wire AND connection for PNP output (Using relays)

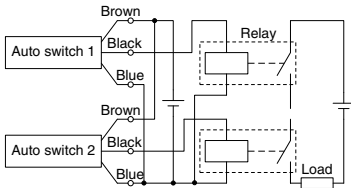

#### (Performed with auto switches only)

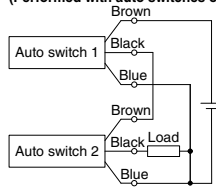

#### 3-wire OR connection for PNP output

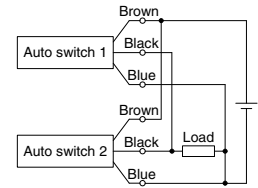

#### 2-wire AND connection

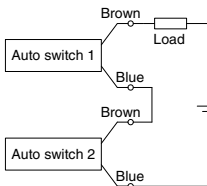

When two auto switches are connected in series, a load may malfunction because the load voltage will decline when in the ON state. The indicator lights will light up when both of the auto switches are in the ON state. Auto switches with load voltage less than 20V cannot be used.

Load voltage at ON = Power supply voltage – Residual voltage x 2 pcs.  
= 24 V – 4 V x 2 pcs.  
= 16 V

Example: Power supply is 24 VDC  
Internal voltage drop in auto switch is 4 V.

#### 2-wire OR connection

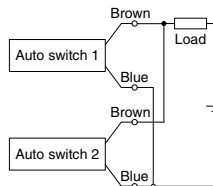

(Solid state)  
When two auto switches are connected in parallel, malfunction may occur because the load voltage will increase when in the OFF state.

(Reed)  
Because there is no current leakage, the load voltage will not increase when turned OFF. However, depending on the number of auto switches in the ON state, the indicator lights may sometimes grow dim or not light up, due to the dispersion and reduction of the current flowing to the auto switches.

Load voltage at OFF = Leakage current x 2 pcs. x Load impedance  
= 1 mA x 2 pcs. x 3 kΩ  
= 6 V

Example: Load impedance is 3 kΩ.  
Leakage current from auto switch is 1 mA.



# Solid State Auto Switches

General Purpose Type, 2-color Indicator, 2-color Indicator with Diagnostic Output, Water Resistant 2-color Indicator, Hygienic Type, Timer Equipped Type, Magnetic Field Resistant Type, Heat Resistant Type, Trimmer Auto Switch

## Solid State Auto Switch Variations

| Type                      | Function  | Auto switch mounting type                | Electrical entry      | Auto switch model                  | Page   |      |
|---------------------------|---|--|-----------------------|------------------------------------|--------|------|
| Solid State Auto Switch   | General purpose                                     | Direct                                   | Grommet               | D-M9N/M9P/M9B                      | 1591   |      |
|                           |   |  |                       | D-M9NV/M9PV/M9BV                   | 1592   |      |
|                           |   |  |                       | D-F8N/F8P/F8B                      | 1592-1 |      |
|                           |   |  |                       | D-M9NE/M9PE/M9BE (Normally closed) | 1593   |      |
|                           |   | D-M9NEV/M9PEV/M9BEV (Normally closed)    | 1593                  |                                    |        |      |
|                           |   | D-F9G/F9H (Normally closed)              | 1594                  |                                    |        |      |
|                           |   | D-Y59A/Y59B/Y7P                          | 1595                  |                                    |        |      |
|                           |   | D-Y69A/Y69B /Y7PV                        | 1597                  |                                    |        |      |
|                           |   | D-Y7G/Y7H (Normally closed)              | 1598                  |                                    |        |      |
|                           |   | D-H7A1/H7A2/H7B                          | 1599                  |                                    |        |      |
|                           |   | D-G59/G5P/K59                            | 1600                  |                                    |        |      |
|                           |   | D-H7C                                    | 1601                  |                                    |        |      |
|                           |   | D-G39/K39                                | 1601                  |                                    |        |      |
|                           |   | D-G39A/K39A                              | 1602                  |                                    |        |      |
|                           |   | D-F79/F7P/J79                            | 1603                  |                                    |        |      |
|                           |   | D-F7NV/F7PV/F7BV                         | 1604                  |                                    |        |      |
|                           | D-J79C  | 1605                                     |                       |                                    |        |      |
|                           | D-F59/F5P/J59                                       | 1606                                     |                       |                                    |        |      |
|                           | D-G39C/K39C   | 1607                                     |                       |                                    |        |      |
|                           | 2-color indicator                                   | Direct                                   | Grommet               | D-M9NW/M9PW/M9BW                   | 1608   |      |
|                           |   |  |                       | D-M9NVV/M9PVV/M9BVV                | 1610   |      |
|                           |   |  |                       | D-Y7NW/Y7PW/Y7BW                   | 1611   |      |
|                           |   |  |                       | D-Y7NVV/Y7PVV/Y7BVV                | 1612   |      |
|                           |   | Band                                     | Grommet               | D-H7NW/H7PW/H7BW                   | 1613   |      |
|                           |   |  |                       | D-G59W/G5PW/K59W                   | 1614   |      |
|                           |   | Rail                                     | Grommet               | D-F79W/F7PW/J79W                   | 1615   |      |
|                           |   |  |                       | D-F7NWV/F7BWW                      | 1616   |      |
|                           |   | Tie-rod                                  | Grommet               | D-F59W/F5PW/J59W                   | 1617   |      |
|                           |   |  |                       | D-H7NF                             | 1618   |      |
|                           |   | 2-color indicator with diagnostic output | Band                  | Grommet                            | D-G59F | 1619 |
|                           |   |  |                       |                                    | D-F79F | 1620 |
|                           | Rail  |  | Grommet               | D-F59F                             | 1621   |      |
|                           |   |  |                       | D-F59F                             | 1622   |      |
|                           | Tie-rod   |  | Grommet               | D-M9PA/M9NA/M9BA                   | 1623   |      |
|                           |   |  |                       | D-M9PAV/M9NAV/M9BAV                | 1624   |      |
|                           | Water resistant 2-color indicator                   | Direct                                   | Grommet               | D-Y7BA                             | 1625   |      |
|                           |   |  |                       | D-H7BA                             | 1626   |      |
|                           |   |  |                       | D-G5BA                             | 1627   |      |
|                           |   |  |                       | D-F7BA                             | 1628   |      |
|                           | Hygienic  | Direct                                   | Grommet               | D-F7BAV                            | 1629   |      |
| D-F5BA                    |   |  |                       | 1630                               |        |      |
| With timer                | Direct  | Grommet                                  | D-F6N/F6P/F6B         | 1631                               |        |      |
|                           |   |  | D-G5NT                | 1632                               |        |      |
|                           |   |  | D-F7NT                | 1633                               |        |      |
|                           |   |  | D-F5NT                | 1634                               |        |      |
| Magnetic field resistance | Rail, Tie-rod, Direct                               | Grommet                                  | D-P3DWASC/P3DWASE     | 1635                               |        |      |
|                           |   |  | D-P3DWA               | 1636                               |        |      |
|                           |   |  | D-P3DWSC/P3DWSE       | 1637                               |        |      |
|                           |   |  | D-P3DW                | 1638                               |        |      |
|                           | Rail  | Grommet                                  | D-P4DWSC/P4DWSE       | 1639                               |        |      |
|                           |   |  | D-P4DW                | 1640                               |        |      |
|                           |   |  | D-M9NJ/M9PJ           | 1641                               |        |      |
|                           |   |  | D-F7NJ                | 1642                               |        |      |
| Heat resistant            | Sensor section: Rail<br>Amplifier section: DIN rail | Grommet                                  | D-M9K/F7K/Y7K/RNK/RPK | 1643                               |        |      |
|                           |   |  | D-F7NJ                | 1644                               |        |      |
| Trimmer Auto Switch       | Rail  | Grommet                                  | D-M9K/F7K/Y7K/RNK/RPK | 1645                               |        |      |
|                           |   |  | D-F7NJ                | 1646                               |        |      |

# Solid State Auto Switch Direct Mounting Type

## D-M9N(V)/D-M9P(V)/D-M9B(V)

 RoHS

### Grommet

- 2-wire load current is reduced (2.5 to 40 mA).
- Using flexible cable as standard spec.



### ⚠ Caution

#### Precautions

Fix the auto switch with the existing screw installed on the auto switch body. The auto switch may be damaged if a screw other than the one supplied is used.

### Auto Switch Specifications

Refer to SMC website for the details of the products conforming to the international standards.

PLC: Programmable Logic Controller

| D-M9□, D-M9□V (With indicator light) |   |               |         |               |                       |               |
|--------------------------------------|---|---------------|---------|---------------|-----------------------|---------------|
| Auto switch model                    | D-M9N   | D-M9NV        | D-M9P   | D-M9PV        | D-M9B                 | D-M9BV        |
| Electrical entry direction           | In-line                                       | Perpendicular | In-line | Perpendicular | In-line               | Perpendicular |
| Wiring type                          | 3-wire  |               |         |               |                       | 2-wire        |
| Output type                          | NPN   |               | PNP     |               | —                     |               |
| Applicable load                      | IC circuit, Relay, PLC                        |               |         |               | 24 VDC relay, PLC     |               |
| Power supply voltage                 | 5, 12, 24 VDC (4.5 to 28 V)                   |               |         |               |                       | —             |
| Current consumption                  | 10 mA or less                                 |               |         |               |                       | —             |
| Load voltage                         | 28 VDC or less                                |               | —       |               | 24 VDC (10 to 28 VDC) |               |
| Load current                         | 40 mA or less                                 |               |         |               |                       | 2.5 to 40 mA  |
| Internal voltage drop                | 0.8 V or less at 10 mA (2 V or less at 40 mA) |               |         |               | 4 V or less           |               |
| Leakage current                      | 100 μA or less at 24 VDC                      |               |         |               | 0.8 mA or less        |               |
| Indicator light                      | Red LED illuminates when turned ON.           |               |         |               |                       |               |
| Standard                             | CE marking, RoHS                              |               |         |               |                       |               |

### Oilproof Heavy-duty Lead Wire Specifications

| Auto switch model                              |                                   | D-M9N(V)                   | D-M9P(V) | D-M9B(V)             |
|--|-----------------------------------|----------------------------|----------|----------------------|
| Sheath   | Outside diameter [mm]             | 2.6                        |          |                      |
| Insulator                                      | Number of cores                   | 3 cores (Brown/Blue/Black) |          | 2 cores (Brown/Blue) |
|  | Outside diameter [mm]             | 0.88                       |          |                      |
| Conductor                                      | Effective area [mm <sup>2</sup> ] | 0.15                       |          |                      |
|  | Strand diameter [mm]              | 0.05                       |          |                      |
| Minimum bending radius [mm] (Reference values) |                                   | 17                         |          |                      |

Note 1) Refer to page 1584 for solid state auto switch common specifications.

Note 2) Refer to page 1584 for lead wire lengths.

### Weight

(g)

| Auto switch model |             | D-M9N(V) | D-M9P(V) | D-M9B(V) |
|-------------------|-------------|----------|----------|----------|
| Lead wire length  | 0.5 m (Nii) | 8        | 7        | 7        |
|                   | 1 m (M)     | 14       | 13       | 13       |
|                   | 3 m (L)     | 41       | 38       | 38       |
|                   | 5 m (Z)     | 68       | 63       | 63       |

### Dimensions

(mm)

#### D-M9□

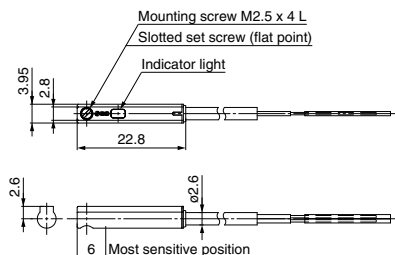

#### D-M9□V

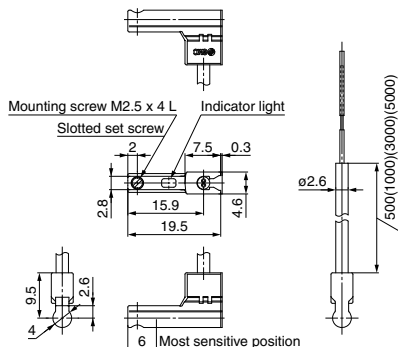



# Solid State Auto Switch Direct Mounting Type D-F8N/D-F8P/D-F8B



Refer to SMC website for the details of the products conforming to the international standards.

## Grommet



## Caution

### Precautions

Fix the auto switch with the existing screw installed on the auto switch body. The auto switch may be damaged if a screw other than the one supplied is used.

## Auto Switch Specifications

PLC: Programmable Logic Controller

| D-F8□ (With indicator light) |  |               |                          |
|------------------------------|--|---------------|--------------------------|
| Auto switch model            | D-F8N  | D-F8P         | D-F8B                    |
| Electrical entry direction   | Perpendicular  | Perpendicular | Perpendicular            |
| Wiring type                  | 3-wire   |               | 2-wire                   |
| Output type                  | NPN  | PNP           | —                        |
| Applicable load              | IC circuit, 24 VDC Relay, PLC                          |               | 24 VDC relay, PLC        |
| Power supply voltage         | 5, 12, 24 VDC (4.5 to 28 VDC)                          |               | —                        |
| Current consumption          | 10 mA or less  |               | —                        |
| Load voltage                 | 28 VDC or less   | —             | 24 VDC (10 to 28 VDC)    |
| Load current                 | 40 mA or less  | 80 mA or less | 2.5 to 40 mA             |
| Internal voltage drop        | 1.5 V or less<br>(0.8 V or less at 10 mA load current) | 0.8 V or less | 4 V or less              |
| Leakage current              | 100 μA or less at 24 VDC                               |               | 0.8 mA or less at 24 VDC |
| Indicator light              | Red LED illuminates when turned ON.                    |               |                          |
| Standard                     | CE marking, RoHS                                       |               |                          |

## Oilproof Heavy-duty Lead Wire Specifications

| Auto switch model |  | D-F8N                      | D-F8P | D-F8B                |
|-------------------|--|----------------------------|-------|----------------------|
| Sheath            | Outside diameter [mm]                          | ø2.7                       |       |                      |
|                   | Number of cores                                | 3 cores (Brown/Blue/Black) |       | 2 cores (Brown/Blue) |
| Insulator         | Outside diameter [mm]                          | ø0.91                      |       | ø0.96                |
|                   | Effective area [mm <sup>2</sup> ]              | 0.15                       |       | 0.18                 |
| Conductor         | Strand diameter [mm]                           | ø0.08                      |       |                      |
|                   | Minimum bending radius [mm] (Reference values) | 17                         |       |                      |

Note 1) Refer to page 1584 for solid state auto switch common specifications.

Note 2) Refer to page 1584 for lead wire lengths.

## Weight

(g)

| Auto switch model |             | D-F8N | D-F8P | D-F8B |
|-------------------|-------------|-------|-------|-------|
| Lead wire length  | 0.5 m (NII) | 7     |       |       |
|                   | 3 m (L)     | 32    |       |       |
|                   | 5 m (Z)     | 52    |       |       |

## Dimensions

(mm)

### D-F8N/D-F8P/D-F8B

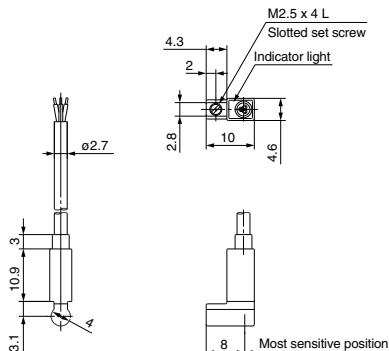

# Normally Closed Solid State Auto Switch Direct Mounting Type

## D-M9NE(V)/D-M9PE(V)/D-M9BE(V)



Refer to SMC website for the details of the products conforming to the international standards.

### Grommet

- Output signal turns on when no magnetic force is detected.
- Can be used for the actuator adopted by the solid state auto switch D-M9 series (excluding special order products)

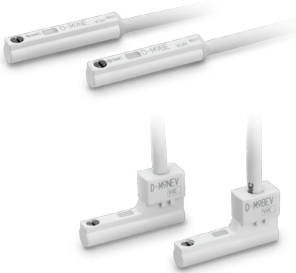

### Caution

#### Precautions

Fix the auto switch with the existing screw installed on the auto switch body. The auto switch may be damaged if a screw other than the one supplied is used.

### Auto Switch Specifications

PLC: Programmable Logic Controller

| D-M9□E, D-M9□EV (With indicator light) |   |               |         |               |                       |               |
|--|---|---------------|---------|---------------|-----------------------|---------------|
| Auto switch model                      | D-M9NE  | D-M9NEV       | D-M9PE  | D-M9PEV       | D-M9BE                | D-M9BEV       |
| Electrical entry direction             | In-line                                       | Perpendicular | In-line | Perpendicular | In-line               | Perpendicular |
| Wiring type                            | 3-wire  |               |         |               | 2-wire                |               |
| Output type                            | NPN   |               |         | PNP           |                       | —             |
| Applicable load                        | IC circuit, Relay, PLC                        |               |         |               | 24 VDC relay, PLC     |               |
| Power supply voltage                   | 5, 12, 24 VDC (4.5 to 28 V)                   |               |         |               | —                     |               |
| Current consumption                    | 10 mA or less                                 |               |         |               | —                     |               |
| Load voltage                           | 28 VDC or less                                |               | —       |               | 24 VDC (10 to 28 VDC) |               |
| Load current                           | 40 mA or less                                 |               |         |               | 2.5 to 40 mA          |               |
| Internal voltage drop                  | 0.8 V or less at 10 mA (2 V or less at 40 mA) |               |         |               | 4 V or less           |               |
| Leakage current                        | 100 $\mu$ A or less at 24 VDC                 |               |         |               | 0.8 mA or less        |               |
| Indicator light                        | Red LED illuminates when turned ON.           |               |         |               |                       |               |
| Standard                               | CE marking, RoHS                              |               |         |               |                       |               |

### Oilproof Heavy-duty Lead Wire Specifications

| Auto switch model                              |                                   | D-M9NE(V)                  | D-M9PE(V) | D-M9BE(V)            |
|--|-----------------------------------|----------------------------|-----------|----------------------|
| Sheath   | Outside diameter [mm]             | 2.6                        |           |                      |
| Insulator                                      | Number of cores                   | 3 cores (Brown/Blue/Black) |           | 2 cores (Brown/Blue) |
|  | Outside diameter [mm]             | 0.88                       |           |                      |
| Conductor                                      | Effective area [mm <sup>2</sup> ] | 0.15                       |           |                      |
|  | Strand diameter [mm]              | 0.05                       |           |                      |
| Minimum bending radius [mm] (Reference values) |                                   | 17                         |           |                      |

Note 1) Refer to page 1584 for solid state auto switch common specifications.  
Note 2) Refer to page 1584 for lead wire lengths.

### Weight

(g)

| Auto switch model |             | D-M9NE(V) | D-M9PE(V) | D-M9BE(V) |
|-------------------|-------------|-----------|-----------|-----------|
| Lead wire length  | 0.5 m (NII) | 8         | 7         | 7         |
|                   | 1 m (M)*    | 14        | 13        | 13        |
|                   | 3 m (L)     | 41        | 38        | 38        |
|                   | 5 m (Z)*    | 68        | 63        | 63        |

\* The 1 m and 5 m options are produced upon receipt of order.

### Dimensions

(mm)

#### D-M9□E

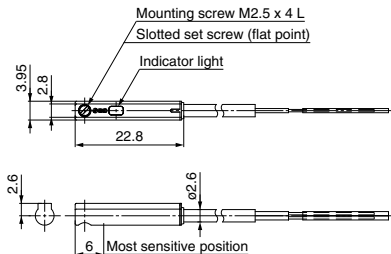

#### D-M9□EV

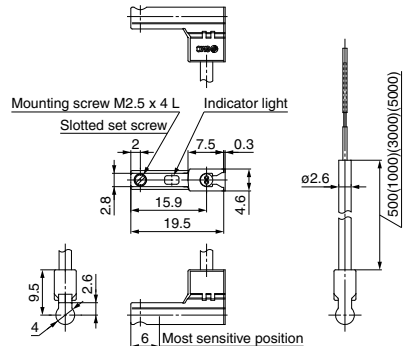

# Solid State Auto Switch Direct Mounting Type D-Y59<sub>A</sub>/D-Y69<sub>A</sub>/D-Y7P(V)

Refer to SMC website for the details of the products conforming to the international standards.

## Grommet

Using flexible cable as standard spec.



## Auto Switch Specifications

PLC: Programmable Logic Controller

| D-Y5□, D-Y6□, D-Y7P, D-Y7PV (With indicator light) |  |               |               |               |                          |               |
|--|--|---------------|---------------|---------------|--------------------------|---------------|
| Auto switch model                                  | D-Y59A   | D-Y69A        | D-Y7P         | D-Y7PV        | D-Y59B                   | D-Y69B        |
| Electrical entry direction                         | In-line  | Perpendicular | In-line       | Perpendicular | In-line                  | Perpendicular |
| Wiring type  | 3-wire   |               |               | 2-wire        |                          |               |
| Output type  | NPN  |               | PNP           |               | —                        |               |
| Applicable load                                    | IC circuit, Relay, PLC                                 |               |               |               | 24 VDC relay, PLC        |               |
| Power supply voltage                               | 5, 12, 24 VDC (4.5 to 28 VDC)                          |               |               |               | —                        |               |
| Current consumption                                | 10 mA or less  |               |               |               | —                        |               |
| Load voltage                                       | 28 VDC or less   |               | —             |               | 24 VDC (10 to 28 VDC)    |               |
| Load current                                       | 40 mA or less  |               | 80 mA or less |               | 2.5 to 40 mA             |               |
| Internal voltage drop                              | 1.5 V or less<br>(0.8 V or less at 10 mA load current) |               | 0.8 V or less |               | 4 V or less              |               |
| Leakage current                                    | 100 μA or less at 24 VDC                               |               |               |               | 0.8 mA or less at 24 VDC |               |
| Indicator light                                    | Red LED illuminates when turned ON.                    |               |               |               |                          |               |
| Standard   | CE marking, RoHS                                       |               |               |               |                          |               |

## Oilproof Flexible Heavy-duty Lead Wire Specifications

| Auto switch model |  | D-Y□9A                     | D-Y7P□ | D-Y□9B               |
|-------------------|--|----------------------------|--------|----------------------|
| Sheath            | Outside diameter [mm]                          | ø3.4                       |        |                      |
|                   | Number of cores                                | 3 cores (Brown/Blue/Black) |        | 2 cores (Brown/Blue) |
| Insulator         | Outside diameter [mm]                          | ø1.0                       |        |                      |
|                   | Effective area [mm <sup>2</sup> ]              | 0.15                       |        |                      |
| Conductor         | Strand diameter [mm]                           | ø0.05                      |        |                      |
|                   | Minimum bending radius [mm] (Reference values) | 21                         |        |                      |

Note 1) Refer to page 1584 for solid state auto switch common specifications.  
Note 2) Refer to page 1584 for lead wire lengths.

## Weight

(g)

| Auto switch model |             | D-Y59A | D-Y69A | D-Y7P(V) | D-Y59B | D-Y69B |
|-------------------|-------------|--------|--------|----------|--------|--------|
| Lead wire length  | 0.5 m (NII) | 10     |        |          | 9      |        |
|                   | 3 m (L)     | 53     |        |          | 50     |        |
|                   | 5 m (Z)     | 87     |        |          | 83     |        |

## Dimensions

(mm)

### D-Y59A/D-Y7P/D-Y59B

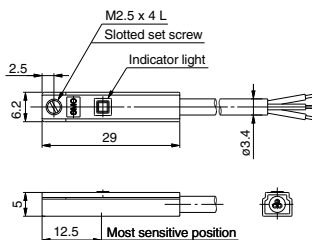

### D-Y69A/D-Y7PV/D-Y69B

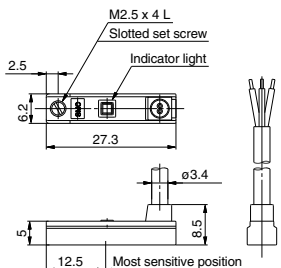

# Normally Closed Solid State Auto Switch Direct Mounting Type D-Y7G/D-Y7H



Refer to SMC website for the details of the products conforming to the international standards.

## Grommet

- Output signal turns on when no magnetic force is detected.
- Using flexible cable as standard spec.



## Auto Switch Specifications

PLC: Programmable Logic Controller

| D-Y7G, D-Y7H (With indicator light) |  |               |
|-------------------------------------|--|---------------|
| Auto switch model                   | D-Y7G  | D-Y7H         |
| Wiring type                         | 3-wire   |               |
| Output type                         | NPN  | PNP           |
| Applicable load                     | IC circuit, Relay, PLC                                 |               |
| Power supply voltage                | 5, 12, 24 VDC (4.5 to 28 VDC)                          |               |
| Current consumption                 | 10 mA or less  |               |
| Load voltage                        | 28 VDC or less   | —             |
| Load current                        | 40 mA or less  | 80 mA or less |
| Internal voltage drop               | 1.5 V or less<br>(0.8 V or less at 10 mA load current) | 0.8 V or less |
| Leakage current                     | 100 $\mu$ A or less at 24 VDC                          |               |
| Indicator light                     | Red LED illuminates when detecting nothing.            |               |
| Standard                            | CE marking, RoHS                                       |               |

## Oilproof Flexible Heavy-duty Lead Wire Specifications

| Auto switch model                              |                                   | D-Y7G                      | D-Y7H |
|--|-----------------------------------|----------------------------|-------|
| Sheath   | Outside diameter [mm]             | $\phi$ 3.4                 |       |
| Insulator                                      | Number of cores                   | 3 cores (Brown/Blue/Black) |       |
|  | Outside diameter [mm]             | $\phi$ 1.0                 |       |
| Conductor                                      | Effective area [mm <sup>2</sup> ] | 0.15                       |       |
|  | Strand diameter [mm]              | $\phi$ 0.05                |       |
| Minimum bending radius [mm] (Reference values) |                                   | 21                         |       |

Note 1) Refer to page 1584 for solid state auto switch common specifications.

Note 2) Refer to page 1584 for lead wire lengths.

## Weight

(g)

| Auto switch model |             | D-Y7G | D-Y7H |
|-------------------|-------------|-------|-------|
| Lead wire length  | 0.5 m (NII) | 10    |       |
|                   | 3 m (L)     | 53    |       |
|                   | 5 m (Z)     | 87    |       |

## Dimensions

(mm)

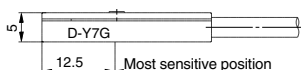
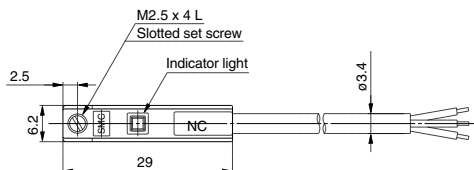

D-□



# Made to Order Specifications: Solid State Auto Switch



Refer to SMC website for the details of the products conforming to the international standards.

## 1 With Pre-wired Connector

- Eliminates the harnessing work by cable with connector specifications
- Adopts global standardized connector (IEC947-5-2)
- IP67 construction



## How to Order

D-**M9N**S**A**PC

Solid state auto switch  
Standard part no.

\* For the applicable auto switch model, refer to the table below.

Cable length

|   |       |
|---|-------|
| S | 0.5 m |
| M | 1.0 m |

Connector model

|   |           |
|---|-----------|
| A | M8-3 pin  |
| B | M8-4 pin  |
| D | M12-4 pin |

(Note) Type A is not selectable for the auto switch with diagnostic output.

## Connector Specifications

| Connector model       | M8-3 pin  | M8-4 pin | M12-4 pin |
|-----------------------|---|----------|-----------|
| Pin arrangement       |   |          |           |
| Conformed standard    | JIS C 4524, JIS C 4525, IEC 947-5-2, NECA 0402                  |          |           |
| Impact resistance     | 300 m/s <sup>2</sup>  |          |           |
| Enclosure             | Only with screw tightened IP67 (IEC60529 standard)              |          |           |
| Insulation resistance | 100 MΩ or more at 500 VDC measured via megohmmeter              |          |           |
| Withstand voltage     | 1500 VAC 1 minute (between contacts), Leak current 1 mA or less |          |           |

## Applicable Auto Switch

For details on the D-P3DWA series magnetic field resistant auto switch, refer to page 1632. And for details on the D-P4DW series, refer to page 1634.

### 2-wire

| Mounting              | Function          | Applicable model  |             |
|-----------------------|-------------------|-------------------|-------------|
| Rail mounting type    | —                 | J79, F7BV         |             |
|                       | 2-color indicator | J79W, F7BWV       |             |
|                       | Water resistant   | F7BA, F7BAV       |             |
| Band mounting type    | —                 | H7B               |             |
|                       | —                 | K59               |             |
|                       | 2-color indicator | H7BW              |             |
|                       | —                 | K59W              |             |
|                       | Water resistant   | H7BA              |             |
|                       | Water resistant   | G5BA              |             |
| Tie-rod mounting type | —                 | J59               |             |
|                       | 2-color indicator | J59W              |             |
|                       | Water resistant   | F5BA              |             |
| Direct mounting type  | —                 | Y59B, Y69B        |             |
|                       |                   | M9B, M9BV         |             |
|                       |                   | F8B               |             |
|                       |                   | M9BE, M9BEV       |             |
|                       | Normally closed   | —                 | M9BE, M9BEV |
|                       |                   | 2-color indicator | Y7BW, Y7BWV |
|                       |                   | Water resistant   | M9BW, M9BWV |
|                       | Water resistant   | —                 | Y7BA        |
|                       |                   | Water resistant   | M9BA, M9BAV |
|                       | Hygienic          | —                 | F6B         |
| —                     |                   | F6B               |             |
| Rotary actuator       | —                 | T791/2            |             |
|                       | —                 | T991/2, T99V1/2   |             |

### 3-wire

| Mounting              | Function          | Applicable model        |                          |
|-----------------------|-------------------|-------------------------|--------------------------|
| Rail mounting type    | —                 | F79, F7P, F7NV, F7PV    |                          |
|                       | 2-color indicator | F79W, F7PW, F7NWV       |                          |
|                       | With timer        | F7NT                    |                          |
| Band mounting type    | —                 | H7A1, H7A2              |                          |
|                       | 2-color indicator | G59, G5P                |                          |
|                       | —                 | H7NW, H7PW              |                          |
|                       | 2-color indicator | G59W, G5PW              |                          |
|                       | With timer        | G5NT                    |                          |
|                       | —                 | F59, F5P                |                          |
| Tie-rod mounting type | —                 | F59, F5P                |                          |
|                       | 2-color indicator | F59W, F5PW              |                          |
|                       | With timer        | F5NT                    |                          |
| Direct mounting type  | —                 | Y59A, Y7P, Y69A, Y7PV   |                          |
|                       |                   | M9N, M9P, M9NV, M9PV    |                          |
|                       |                   | F8N, F8P                |                          |
|                       |                   | Y7G, Y7H                |                          |
|                       | Normally closed   | —                       | F9G, F9H                 |
|                       |                   | —                       | M9NE, M9PE, M9NEV, M9PEV |
|                       |                   | 2-color indicator       | Y7NW, Y7PW, Y7NWV, Y7PWV |
|                       | Water resistant   | 2-color indicator       | M9NW, M9PW, M9NWV, M9PWV |
|                       |                   | Water resistant         | M9NA, M9NAV, M9PA, M9PAV |
|                       | Hygienic          | —                       | F6N, F6P                 |
| —                     |                   | F6N, F6P                |                          |
| Rotary actuator       | —                 | S791/2, S7P1/2          |                          |
|                       | —                 | S991/2, S9P1/2, S99V1/2 |                          |

### 4-wire

| Mounting              | Function             | Applicable model |
|-----------------------|----------------------|------------------|
| Rail mounting type    | Direct mounting type | F79F             |
| Band mounting type    |                      | H7NF             |
| Tie-rod mounting type |                      | G59F             |
|                       |                      | F59F             |

(Note) M8-3 pins are not selectable for the 4-wire auto switch.

## Connector pin arrangement

| Sensor type | Meaning of contact number |                   |       |        |
|-------------|---------------------------|-------------------|-------|--------|
|             | 1 pin                     | 2 pin             | 3 pin | 4 pin  |
| 2-wire      | OUT(+)                    | —                 | —     | OUT(-) |
| 3-wire      | DC(+)                     | —                 | DC(-) | OUT    |
| 4-wire      | DC(+)                     | Diagnostic output | DC(-) | OUT    |

Note1) For details on the D-P3DWASC and D-P3DWASE, refer to page 1630. And for details on the D-P4DWSC and D-P4DWSE, refer to page 1634.

Note2) For details on the pin arrangement, refer to the pin arrangement in the connector specifications above.

# With Pre-wired Connector

## Dimensions



M8-3 pin  
4 pin



M8-4 pin



M12-4 pin

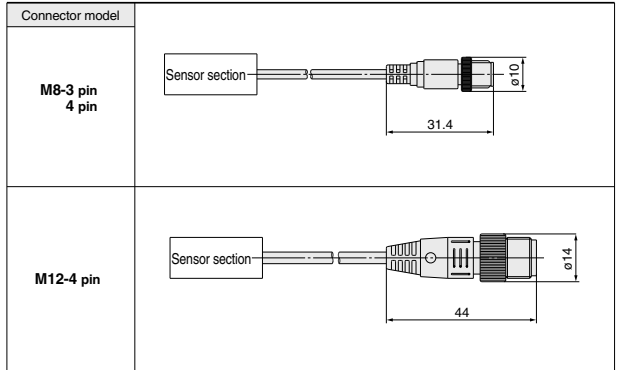

## Connection (Female side) Connector Cable

As the parts are not supplied from SMC, refer to the application examples listed in the below.  
(For detail such as catalog availability, etc., please contact each manufacturer.)

| Connector size | Number of pins | Manufacturer              | Applicable series example |
|----------------|----------------|---------------------------|---------------------------|
| M8             | 3              | Phoenix Contact           | SAC-3P                    |
|                |                | Corrence Corporation      | M8-3D                     |
|                |                | OMROM Corporation         | M8-4D                     |
| M12            | 4              | Phoenix Contact           | SAC-4P                    |
|                |                | Corrence Corporation      | VA-4D                     |
|                |                | OMROM Corporation         | XS2                       |
|                |                | Azbil Corp.               | PA5-4I                    |
|                |                | HIROSE ELECTRIC CO., LTD. | HR24                      |
|                |                | DDK Ltd.                  | CM01-8DP4S                |

## Weight for Connector Type

| Part no. | Connector type | Weight     |
|----------|----------------|------------|
| D-□□□APC | M8-3 pin       | 4 g        |
| D-□□□BPC | M8-4 pin       | 4 g        |
| D-□□□DPC | M12-4 pin      | About 11 g |



# Made to Order Specifications: Solid State Auto Switch

## -50: Without Indicator Light (Dark room) Specifications

## -61: Oilproof Flexible Heavy-duty Cord Specifications

### 2 Without Indicator Light (for dark room specifications)

Symbol

-50

Possible to use under the environment which hates a light.

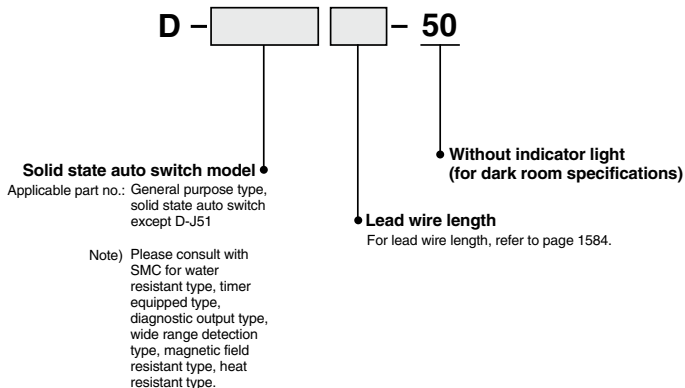

Dimensions and specifications are common as standard products with the exception of no indicator light.

### 3 Oilproof Flexible Heavy-duty Cord Specifications

Symbol

-61

This is the product which uses a heavy-duty cord having flexible characteristics 5 times (SMC comparison) as strong as oilproof heavy-duty cord used in the standard products.

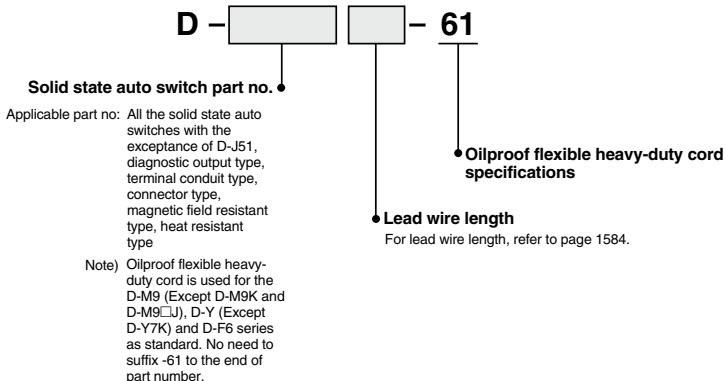

Specifications are the same as standard products with the exception of lead wire specifications.

Lead wire: For D-F8 type..... ø2.7, 0.15 mm<sup>2</sup>, 3 cores (Brown, Blue, Black), 2 cores (Brown, Blue)  
For other model nos..... ø3.4, 0.15 mm<sup>2</sup>, 3 cores (Brown, Blue, Black), 2 cores (Brown, Blue)

Dimensions are identical with D-F5 type, G5 type, J59 type, K59 type. Lead wire diameter is changed from ø4 to ø3.4. In other series products, it is common as standard product's specifications.