

# Series 10-AFF

## Main Line Filter

RoHS

Can remove impurities such as oil, water and foreign matter in compressed air and can improve the function of a dryer in the downstream, extend the replacement period of precision filter element, and prevent trouble with the equipment.

Modular connection is possible with 10-AFF2C to 22C.

(For details, refer to page 1001.)



10-AFF2C to 22C



10-AFF37B/75B

### Caution

Be sure to read this before handling.  
Refer to page 1382 for Safety Instructions and pages 1064 to 1066 for Air Preparation Equipment Precautions.

### Model

Model	10-AFF2C	10-AFF4C	10-AFF8C	10-AFF11C	10-AFF22C	10-AFF37B	10-AFF75B
Rated flow <sup>Note)</sup> (L/min [ANR])	300	750	1500	2200	3700	6000	12000
Port size	1/8, 1/4	1/4, 3/8	3/8, 1/2	1/2, 3/4	3/4, 1	1, 1 1/2	1 1/2, 2
Weight (kg)	0.38	0.55	0.9	1.4	2.1	4.2	10.5

Note) Maximum flow capacity at 0.7 MPa.

Maximum flow capacity varies depending on the operating pressure.

Refer to Flow Rate Characteristics (page 962) and Max. Flow Capacity Line below.

### Specifications

Fluid	Compressed air
Max. operating pressure	1.0 MPa
Min. operating pressure	0.05 MPa
Proof pressure	1.5 MPa
Ambient and fluid temperature	5 to 60°C
Nominal filtration rating	3 μm (Filtration efficiency: 99%)
Element replacement period	2 years or when pressure drop reached 0.1 MPa
Cleanliness class (ISO class)	Class 3

### Accessory/For 10-AFF2C to 22C, 10-AFF37B/75B

Applicable model	10-AFF2C	10-AFF4C	10-AFF8C	10-AFF11C	10-AFF22C	10-AFF37B	10-AFF75B
Bracket assembly (with 2 mounting screws)	10-AM-BM101	10-AM-BM102	10-AM-BM103	10-AM-BM104	10-AM-BM105	10-BM56	10-BM57

### Model Selection

Select a model in accordance with the following procedure taking the inlet pressure and the maximum flow capacity into consideration.

(Example) Inlet pressure: 0.6 MPa

Maximum flow capacity: 5 m<sup>3</sup>/min [ANR]

1. Obtain the intersecting point A of inlet pressure and maximum flow capacity in the graph.
2. The 10-AFF37B is obtained when the max. flow capacity line is above the intersecting point A in the graph.

Note) Make sure to select a model that has the max. flow capacity line above the obtained intersecting point. With a model that has the max. flow capacity line below the obtained intersecting point, the flow rate will be exceeded, thus leading to a problem such as being unable to satisfy the specifications.

### Max. Flow Capacity Line

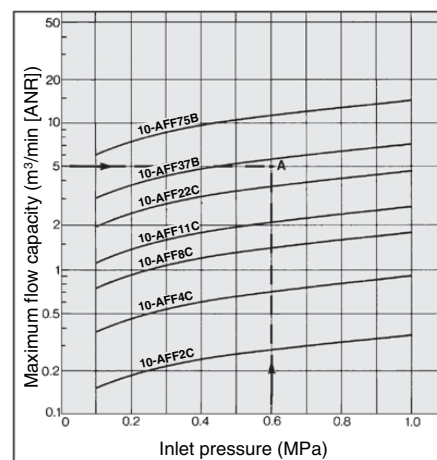



### How to Order

#### 10-AFF2C to 10-AFF22C

**10-AFF 22C - [ ] 10 [ ] - J [ ]**

Clean series

Body size

2C
4C
8C
11C
22C

Thread type

Symbol	Type
Nil	Rc
F	G
N	NPT

Port size

Symbol	Size	Applicable body size				
		2C	4C	8C	11C	22C
01	1/8	●				
02	1/4	●	●			
03	3/8		●	●		
04	1/2			●	●	
06	3/4				●	●
10	1					●

Option

Symbol	Description
Nil	—
F	Rubber material: Fluororubber*3
H	For medium air pressure (1.6 MPa)*3
R	IN-OUT reversal direction
T	With element service indicator*3

\*3 Combination of T and F or H is not available.

Drain guide\*2 1/4 female thread

\*2 Drain piping and piping for a stop valve such as ball valve are required.

Accessory

Symbol	Description
Nil	—
B	Bracket *1

\*1 Bracket is included (but not assembled).

### Options

#### Symbol F: Rubber material: Fluororubber

Fluororubber is used for the parts such as O-ring and gasket.

#### Symbol H: For medium air pressure (1.6 MPa)

Can be used up to 1.6 MPa at maximum.

#### Symbol R: IN-OUT reversal direction

Air flow direction is changed to right to left.  
(Air flow direction of the standard: Left to right.)

#### Symbol T: With element service indicator

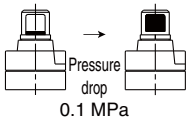

Saturation of the element can be observed visually.

Directional Control Valves

Air Cylinders

Rotary Actuators

Air Grippers

Air Preparation Equipment

Modular F. R.

Pressure Control Equipment

Fittings & Tubing

Flow Control Equipment

Pressure Switches/ Pressure Sensors

**How to Order**



**10-AFF37B, 75B**

**10 - AFF 37B - [ ] 10 [ ] - J [ ]**

Clean series

Body size

37B
75B

Thread type

Symbol	Type
Nil	Rc
F	G
N	NPT

Port size

Symbol	Size	Applicable body size	
		37B	75B
10	1	●	—
14	1 1/2	●	●
20	2	—	●

Option

Symbol	Description
Nil	—
R	IN-OUT reversal direction
T	With element service indicator

Drain guide\*2 1/4 female thread (10-AFF37B),  
3/8 female thread (10-AFF75B)

\*2 Drain piping and piping for a stop valve such as ball valve are required.

Accessory

Symbol	Description
Nil	—
B	Bracket *1

\*1 Bracket is included (but not assembled).

**Flow Rate Characteristics/Select the model under the max. flow capacity line. (Element oil saturation)**

Note) Compressed air over max. flow capacity line in the table below may not meet the specifications of the product.

**10-AFF2C**

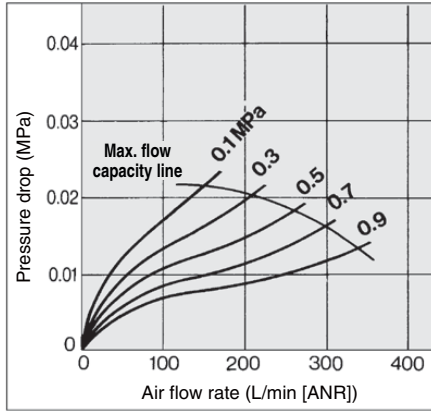

**10-AFF11C**

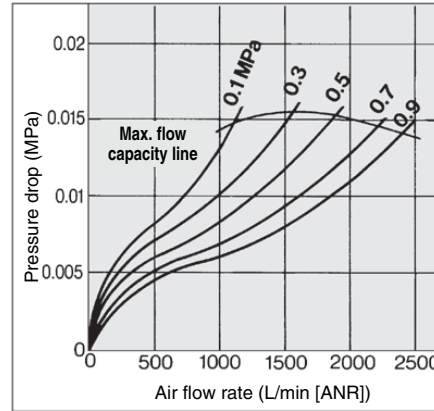

**10-AFF75B**

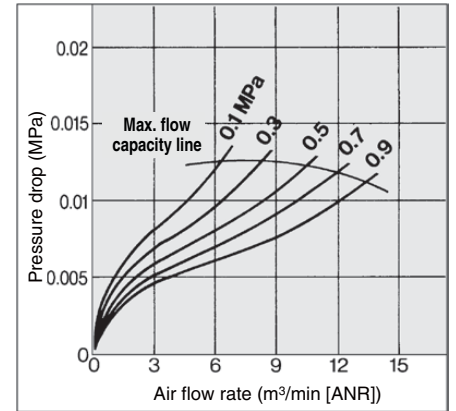

**10-AFF4C**

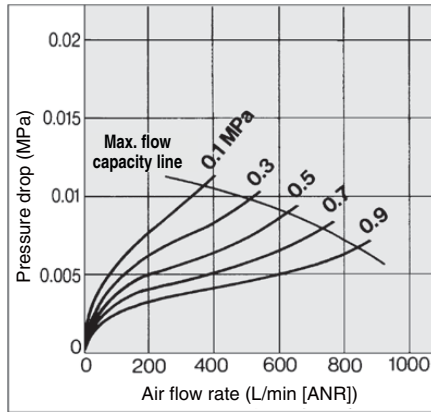

**10-AFF22C**

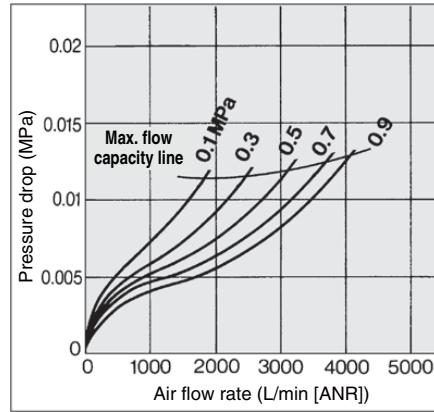

**10-AFF8C**

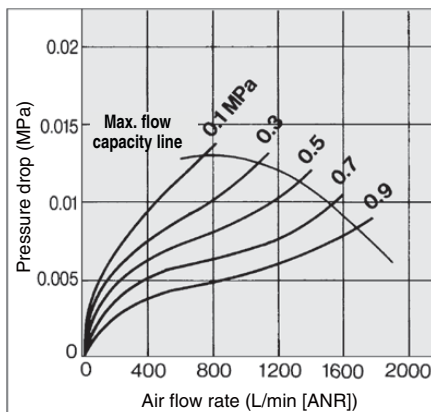

**10-AFF37B**

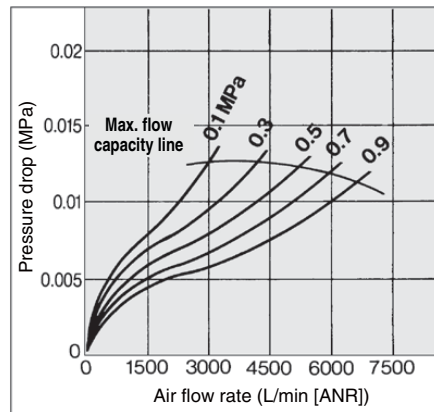

Directional Control Valves

Air Cylinders

Rotary Actuators

Air Grippers

Air Preparation Equipment

Modular F. R.

Pressure Control Equipment

Fittings & Tubing

Flow Control Equipment

Pressure Switches/ Pressure Sensors

**Construction**

**10-AFF2C to 22C, 10-AFF37B**

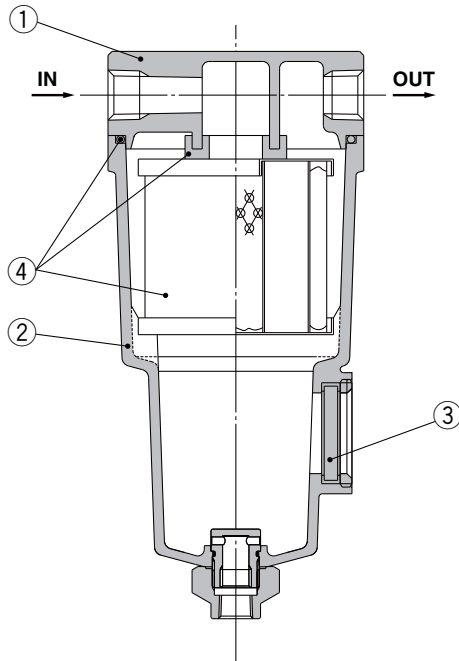

**10-AFF75B**

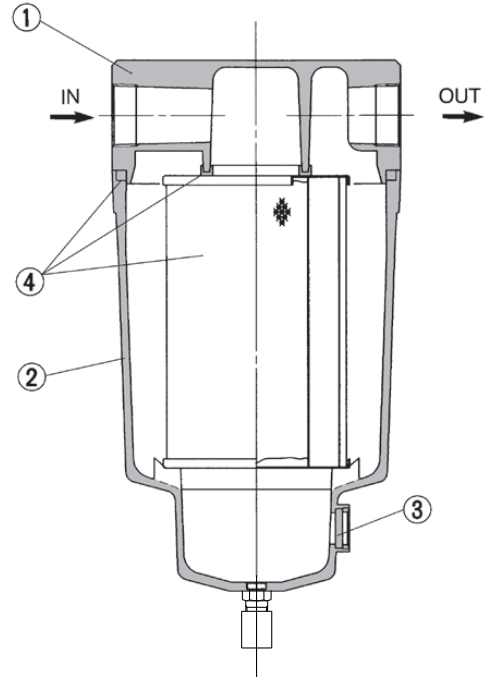

**Component Parts**

No.	Description	Material	Note
1	<b>Body</b>	Aluminum die-casted	Inner/outer surface coating
2	<b>Housing</b>	Aluminum die-casted*	
3	<b>Sight glass</b>	Tempered glass	—

\* The 10-AFF75B is aluminum casted.

Note) Sight glass is indicated in the figure for easy understanding of component parts. However, it differs from the actual construction. Refer to Dimensions on pages 964 to 965 for details.

**Replacement Parts**

No.	Description	Material	Applicable model	Model						
				10-AFF2C	10-AFF4C	10-AFF8C	10-AFF11C	10-AFF22C	10-AFF37B	10-AFF75B
4	<b>Element assembly</b>	Cotton paper, others	Except option F	10-AFF-EL2B	10-AFF-EL4B	10-AFF-EL8B	10-AFF-EL11B	10-AFF-EL22B	10-AFF-EL37B	10-AFF-EL75B
			For option F	10-AFF-EL2B-F	10-AFF-EL4B-F	10-AFF-EL8B-F	10-AFF-EL11B-F	10-AFF-EL22B-F	—	—

- Element assembly: With gasket (1 pc.) and O-ring (1 pc.)
- Refer to How to Order Bowl Assembly on page 1002.

**Dimensions**

**10-AFF2C to 22C**

**Option**

**T: With element service indicator**

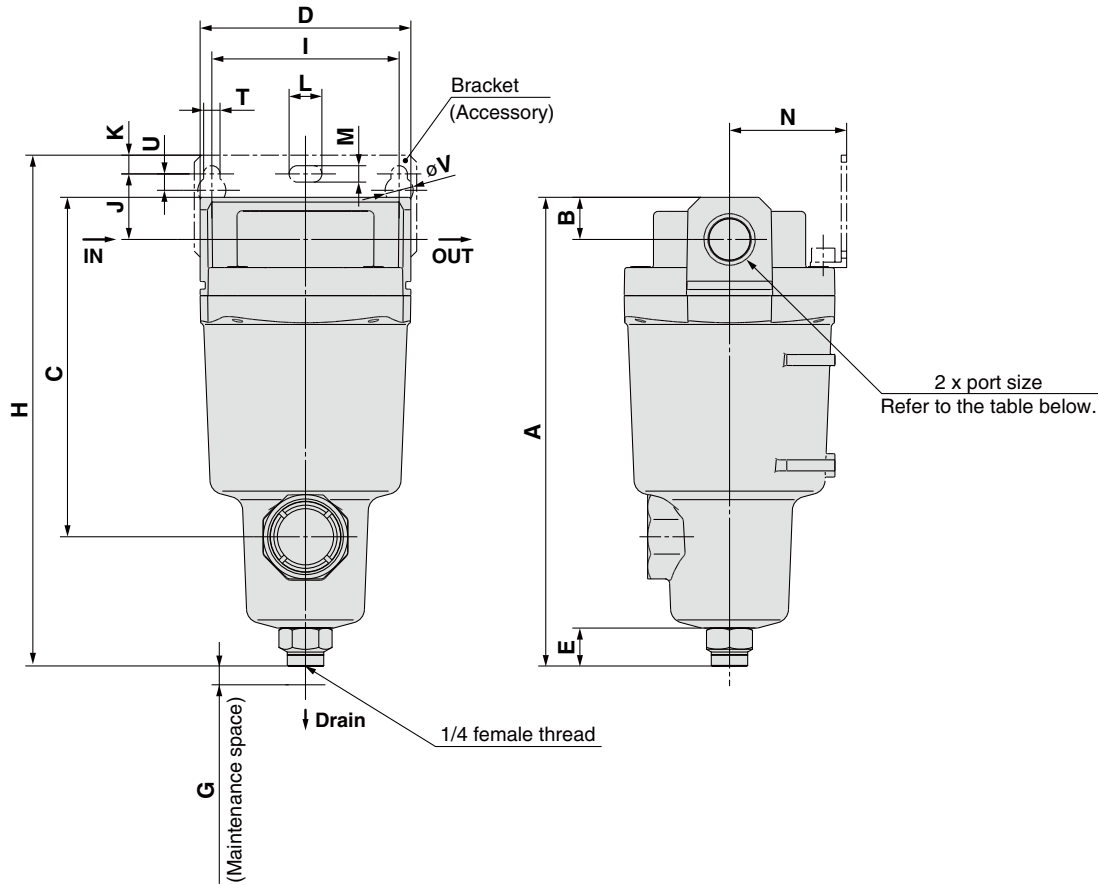
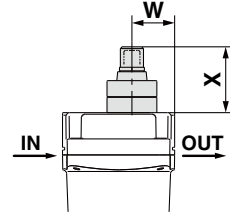
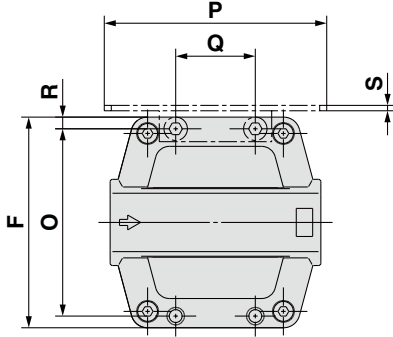

Model	Port size	A	B	C	D	E	F	G	Bracket related dimensions											Element service indicator related dimensions					
									H	I	J	K	T	U	L	M	V	N	O	P	Q	R	S	W	X
<b>10-AFF2C</b>	1/8, 1/4	158	10	99	63	20	63	10	173	56	20	5	6	6	12	6	10	35	54	70	26	4.5	1.6	24	37
<b>10-AFF4C</b>	1/4, 3/8	172	14	113	76	20	76	10	190	66	24	8	6	6	12	6	10	40	66	80	28	5	2	27	37
<b>10-AFF8C</b>	3/8, 1/2	204	18	145	90	20	90	10	222	80	28	8	7	7	14	7	12	50	80	95	34	5	2.3	32	37
<b>10-AFF11C</b>	1/2, 3/4	225	20	166	106	20	106	10	246	90	31	10	9	9	18	9	15	55	88	111	50	9	3.2	37	37
<b>10-AFF22C</b>	3/4, 1	259	24	200	122	20	122	15	278	100	33	10	9	9	18	9	15	65	102	126	60	10	3.2	39	37

- Directional Control Valves
- Air Cylinders
- Rotary Actuators
- Air Grippers
- Air Preparation Equipment**
- Modular F. R.
- Pressure Control Equipment
- Fittings & Tubing
- Flow Control Equipment
- Pressure Switches/ Pressure Sensors

**Dimensions**

**10-AFF37B**

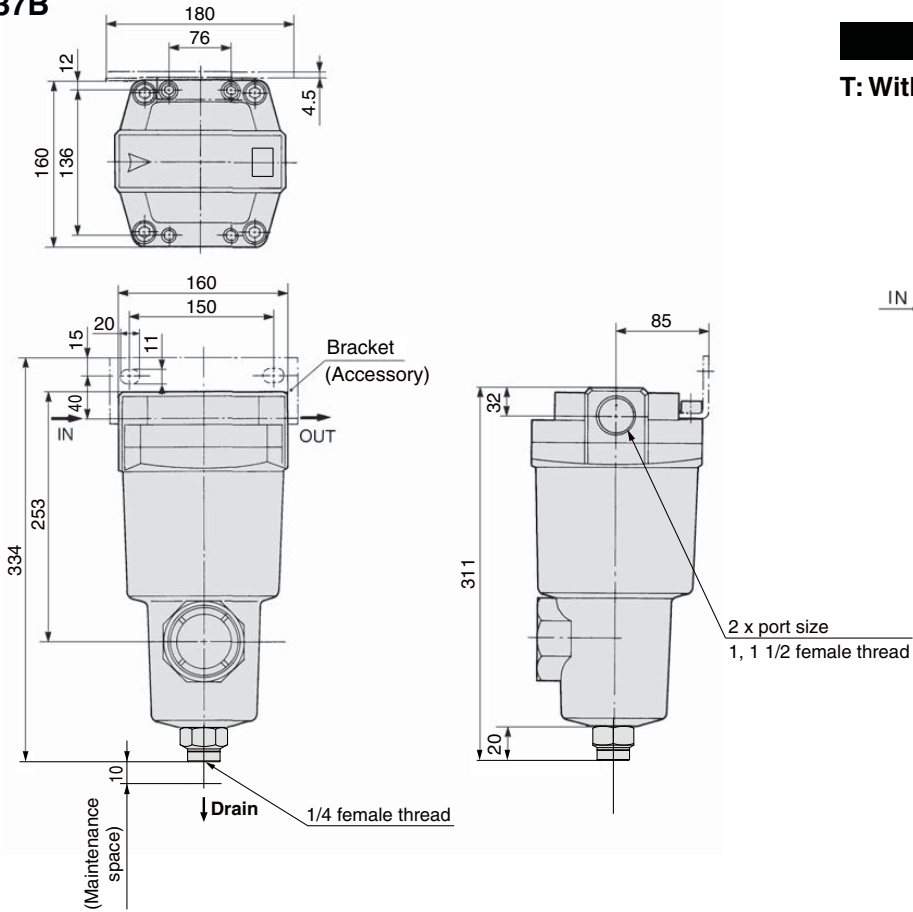

**Option**

**T: With element service indicator**

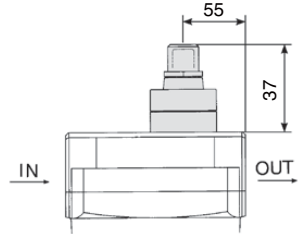

**10-AFF75B**

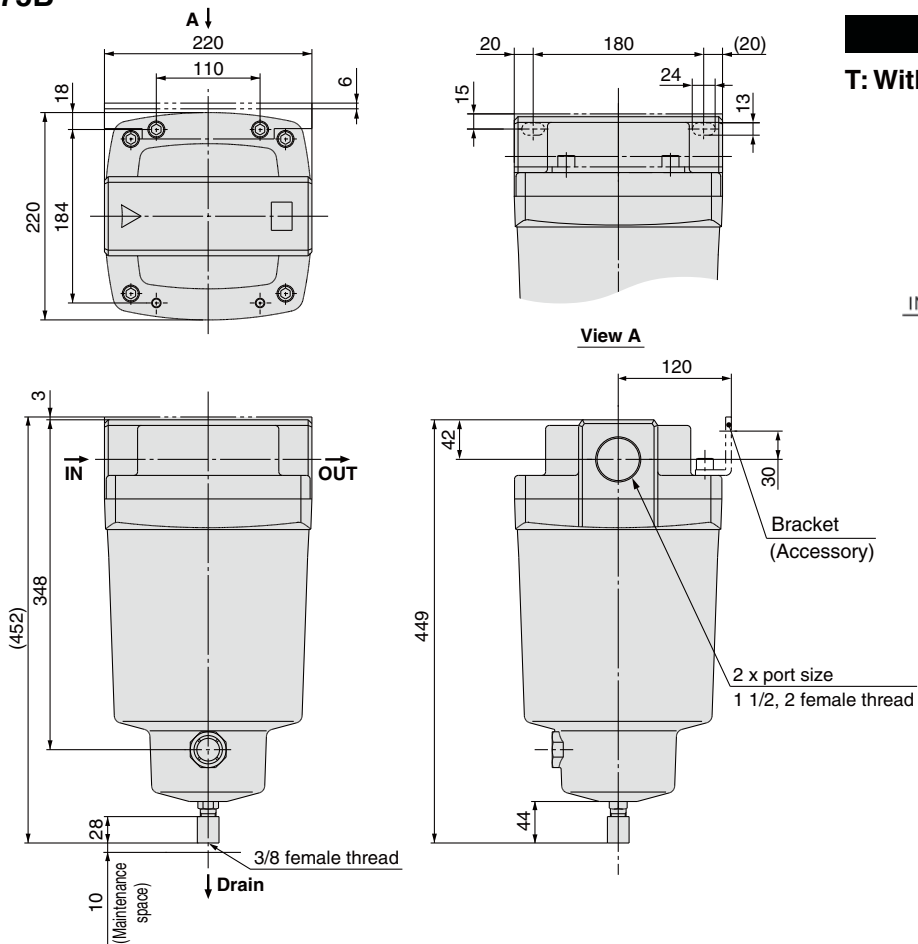

**Option**

**T: With element service indicator**

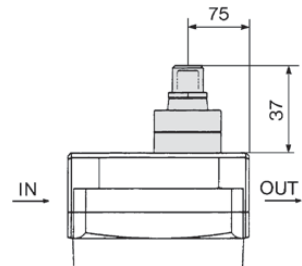

# Series 10-AM Mist Separator

RoHS

Can remove oil mist in compressed air and remove particles such as rust or carbon of more than 0.3 μm.

Modular connection is possible with 10-AM150C to 550C. (For details, refer to page 1001.)



10-AM150C to 550C

10-AM650/850

## Model

Model	10-AM150C	10-AM250C	10-AM350C	10-AM450C	10-AM550C	10-AM650	10-AM850
Rated flow (L/min [ANR]) <sup>Note)</sup>	300	750	1500	2200	3700	6000	12000
Port size	1/8, 1/4	1/4, 3/8	3/8, 1/2	1/2, 3/4	3/4, 1	1, 1 1/2	1 1/2, 2
Weight (kg)	0.38	0.55	0.9	1.4	2.1	4.2	10.5

Note) Maximum flow capacity at 0.7 MPa.

Maximum flow capacity varies depending on the operating pressure.

Refer to Flow Rate Characteristics (page 969) and Max. Flow Capacity Line (page 970).

## Specifications

Fluid	Compressed air
Max. operating pressure	1.0 MPa
Min. operating pressure	0.05 MPa
Proof pressure	1.5 MPa
Ambient and fluid temperature	5 to 60°C
Nominal filtration rating	0.3 μm (Filtration efficiency: 99.9%)
Oil mist density at outlet	Max. 1.0 mg/m <sup>3</sup> [ANR] (≈0.8 ppm)*1
Element replacement period	2 years or when pressure drop reached 0.1 MPa
Cleanliness class (ISO class)	Class 3

\*1 Oil mist density at 30 mg/m<sup>3</sup> [ANR] blown out by compressor.

## Accessory

Applicable model	10-AM150C	10-AM250C	10-AM350C	10-AM450C	10-AM550C	10-AM650	10-AM850
Bracket assembly (with 2 mounting screws)	10-AM-BM101	10-AM-BM102	10-AM-BM103	10-AM-BM104	10-AM-BM105	10-BM56	10-BM57

## ⚠ Caution

Be sure to read this before handling.  
Refer to page 1382 for Safety Instructions and pages 1064 to 1066 for Air Preparation Equipment Precautions.

Directional Control Valves

Air Cylinders

Rotary Actuators

Air Grippers

Air Preparation Equipment

Modular F. R.

Pressure Control Equipment

Fittings & Tubing

Flow Control Equipment

Pressure Switches/ Pressure Sensors



**How to Order**



**10-AM150C to 550C**

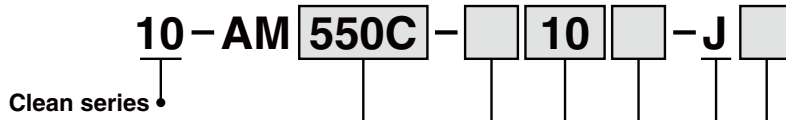

**Body size**

150C
250C
350C
450C
550C

**Thread type**

Symbol	Type
Nil	Rc
F	G
N	NPT

**Port size**

Symbol	Size	Applicable body size				
		150C	250C	350C	450C	550C
01	1/8	●				
02	1/4	●				
03	3/8		●	●		
04	1/2			●	●	
06	3/4				●	●
10	1					●

**Option**

Symbol	Description
Nil	—
F	Rubber material: Fluororubber <sup>*3</sup>
H	For medium air pressure (1.6 MPa) <sup>*3</sup>
R	IN-OUT reversal direction
T	Element service indicator <sup>*3</sup>

<sup>\*3</sup> Combination of T and F or H is not available.

**Drain guide<sup>\*2</sup> 1/4 female thread**

<sup>\*2</sup> Drain piping and piping for a stop valve such as ball valve are required.

**Accessory**

Symbol	Description
Nil	—
B	Bracket <sup>*1</sup>

<sup>\*1</sup> Bracket is included (but not assembled).

**Options**

**Symbol F: Rubber material: Fluororubber**

Fluororubber is used for the parts such as O-ring and gasket.

**Symbol H: For medium air pressure (1.6 MPa)**

Can be used up to 1.6 MPa at maximum.

**Symbol R: IN-OUT reversal direction**

Air flow direction is changed to right to left.  
(Air flow direction of the standard: Left to right.)

**Symbol T: With element service indicator**

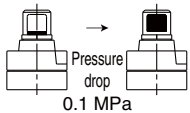

Saturation of the element can be observed visually.



### How to Order

#### 10-AM650/850

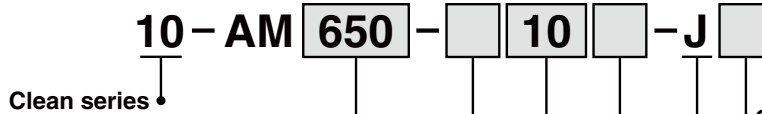

Clean series

Body size

650
850

Thread type

Symbol	Type
Nil	Rc
F	G
N	NPT

Port size

Symbol	Size	Applicable body size	
		650	850
10	1	●	—
14	1 1/2	●	●
20	2	—	●

Option

Symbol	Description
Nil	—
R	IN-OUT reversal direction
T	With element service indicator

Drain guide \*2 1/4 female thread (10-AM650),  
3/8 female thread (10-AM850)

\*2 Drain piping and piping for a stop valve such as ball valve are required.

Accessory

Symbol	Description
Nil	—
B	Bracket *1

\*1 Bracket is included (but not assembled).

Directional Control Valves

Air Cylinders

Rotary Actuators

Air Grippers

Air Preparation Equipment

Modular F. R.

Pressure Control Equipment

Fittings & Tubing

Flow Control Equipment

Pressure Switches/ Pressure Sensors

**Flow Rate Characteristics/Select the model under the max. flow capacity line. (Element oil saturation)**

Note) Compressed air over max. flow capacity line in the table below may not meet the specifications of the product.

**10-AM150C**

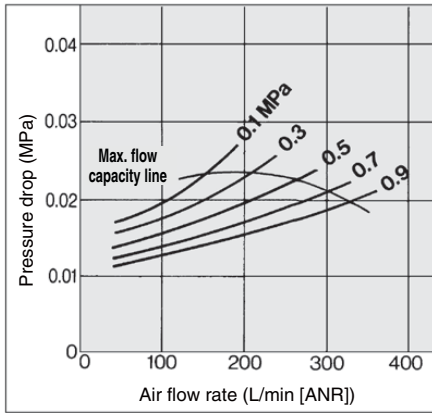

**10-AM450C**

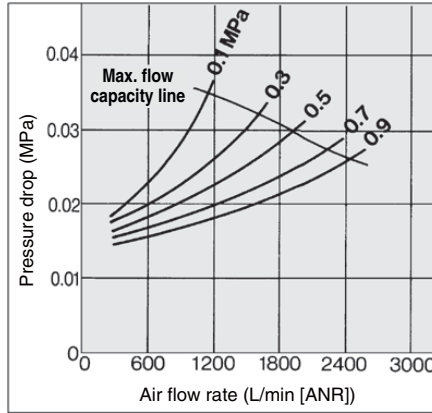

**10-AM850**

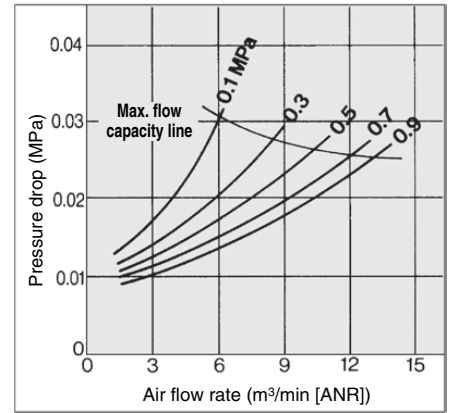

**10-AM250C**

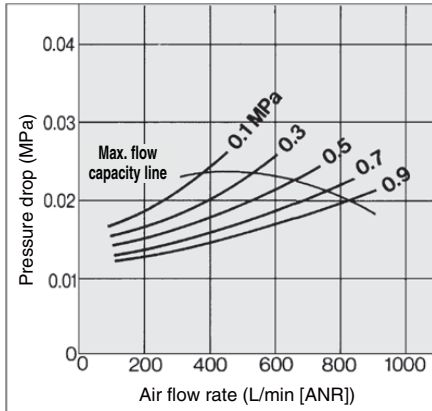

**10-AM550C**

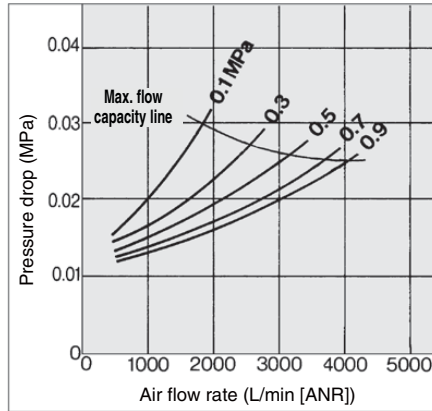

**10-AM350C**

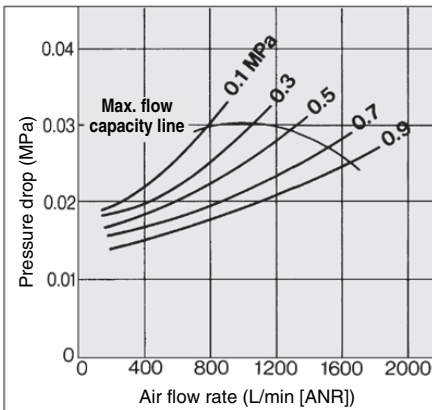

**10-AM650**

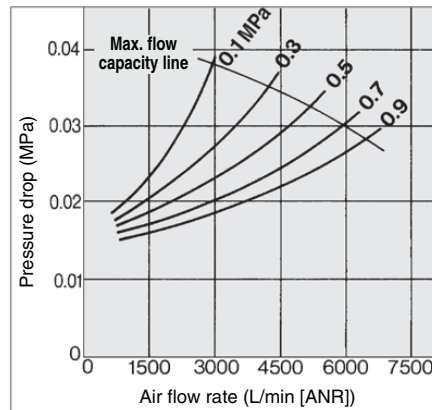

## Construction

### 10-AM150C to 550C, 10-AM650

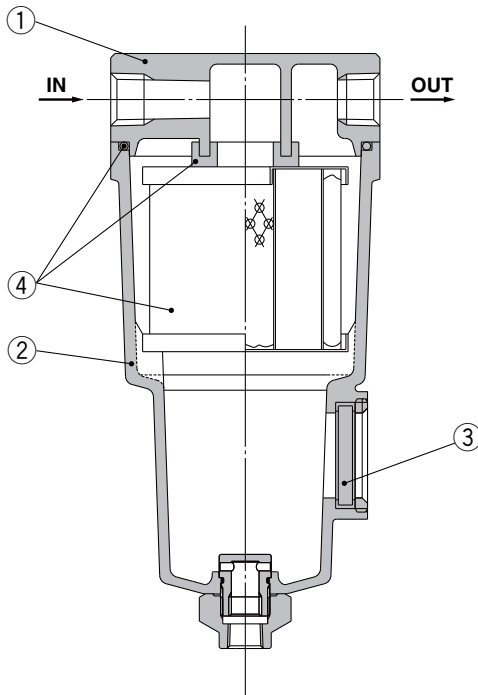

### 10-AM850

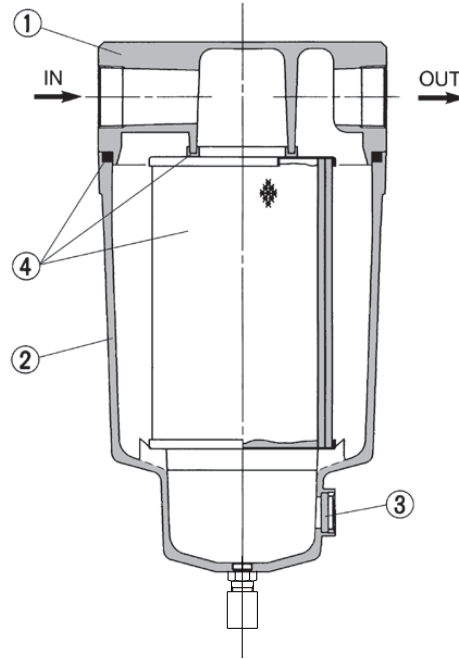

### Component Parts

No.	Description	Material	Note
1	<b>Body</b>	Aluminum die-casted	Inner/outer surface coating
2	<b>Housing</b>	Aluminum die-casted*	
3	<b>Sight glass</b>	Tempered glass	—

\* The 10-AM850 is aluminum casted.

Note) Sight glass is indicated in the figure for easy understanding of component parts. However, it differs from the actual construction. Refer to Dimensions on pages 971 to 972 for details.

### Replacement Parts

No.	Description	Material	Applicable model	Model						
				10-AM150C	10-AM250C	10-AM350C	10-AM450C	10-AM550C	10-AM650	10-AM850
4	<b>Element assembly</b>	Glass fiber, others	Except option F	10-AM-EL150	10-AM-EL250	10-AM-EL350	10-AM-EL450	10-AM-EL550	10-AM-EL650	10-AM-EL850
			For option F	10-AM-EL150-F	10-AM-EL250-F	10-AM-EL350-F	10-AM-EL450-F	10-AM-EL550-F	—	—

- Element assembly: With gasket (1 pc.) and O-ring (1 pc.)
- Refer to How to Order Bowl Assembly on page 1002.

## Max. Flow Capacity Line

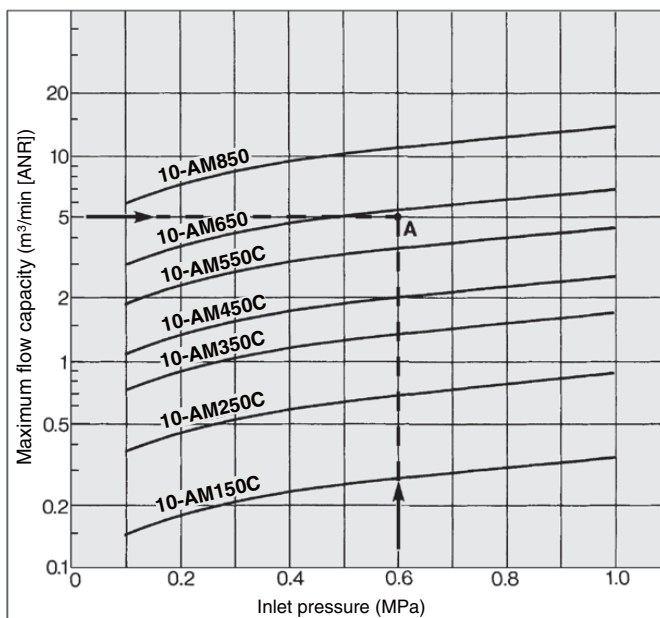

## Model Selection

Select a model in accordance with the following procedure taking the inlet pressure and the maximum flow capacity into consideration.  
(Example) Inlet pressure: 0.6 MPa

Maximum flow capacity: 5 m<sup>3</sup>/min [ANR]

1. Obtain the intersecting point A of inlet pressure and maximum flow capacity in the graph.
2. The 10-AM650 is obtained when the max. flow capacity line is above the intersecting point A in the graph.

Note) Make sure to select a model that has the max. flow capacity line above the obtained intersecting point. With a model that has the max. flow capacity line below the obtained intersecting point, the flow rate will be exceeded, thus leading to a problem such as being unable to satisfy the specifications.

**Dimensions**

**10-AM150C to 550C**

**Option**

**T: With element service indicator**

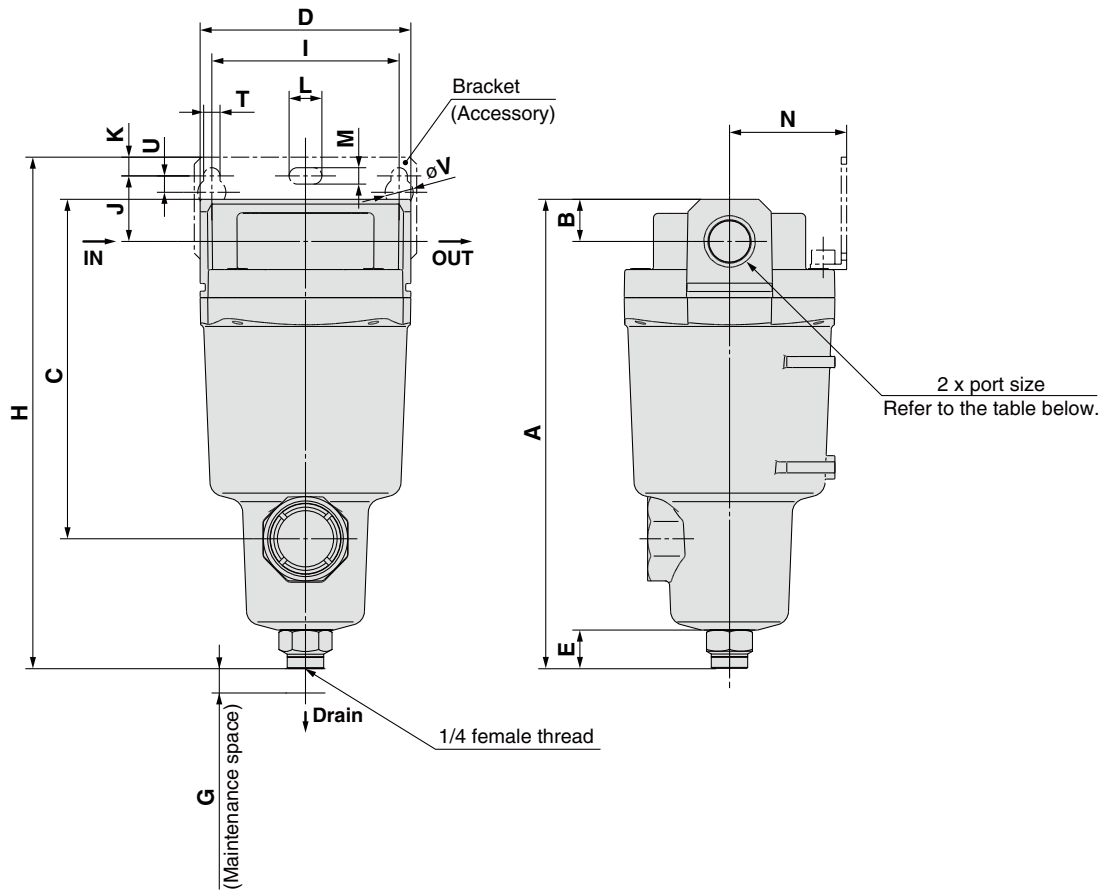
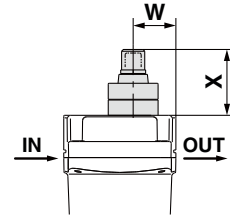
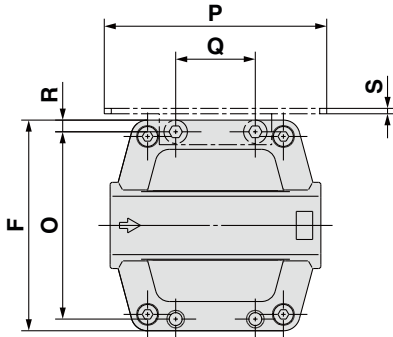

(mm)

Model	Port size	A	B	C	D	E	F	G	Bracket related dimensions											Element service indicator related dimensions					
									H	I	J	K	T	U	L	M	V	N	O	P	Q	R	S	W	X
<b>10-AM150C</b>	1/8, 1/4	158	10	99	63	20	63	10	173	56	20	5	6	6	12	6	10	35	54	70	26	4.5	1.6	24	37
<b>10-AM250C</b>	1/4, 3/8	172	14	113	76	20	76	10	190	66	24	8	6	6	12	6	10	40	66	80	28	5	2	27	37
<b>10-AM350C</b>	3/8, 1/2	204	18	145	90	20	90	10	222	80	28	8	7	7	14	7	12	50	80	95	34	5	2.3	32	37
<b>10-AM450C</b>	1/2, 3/4	225	20	166	106	20	106	10	246	90	31	10	9	9	18	9	15	55	88	111	50	9	3.2	37	37
<b>10-AM550C</b>	3/4, 1	259	24	200	122	20	122	15	278	100	33	10	9	9	18	9	15	65	102	126	60	10	3.2	39	37

**Dimensions**

**10-AM650**

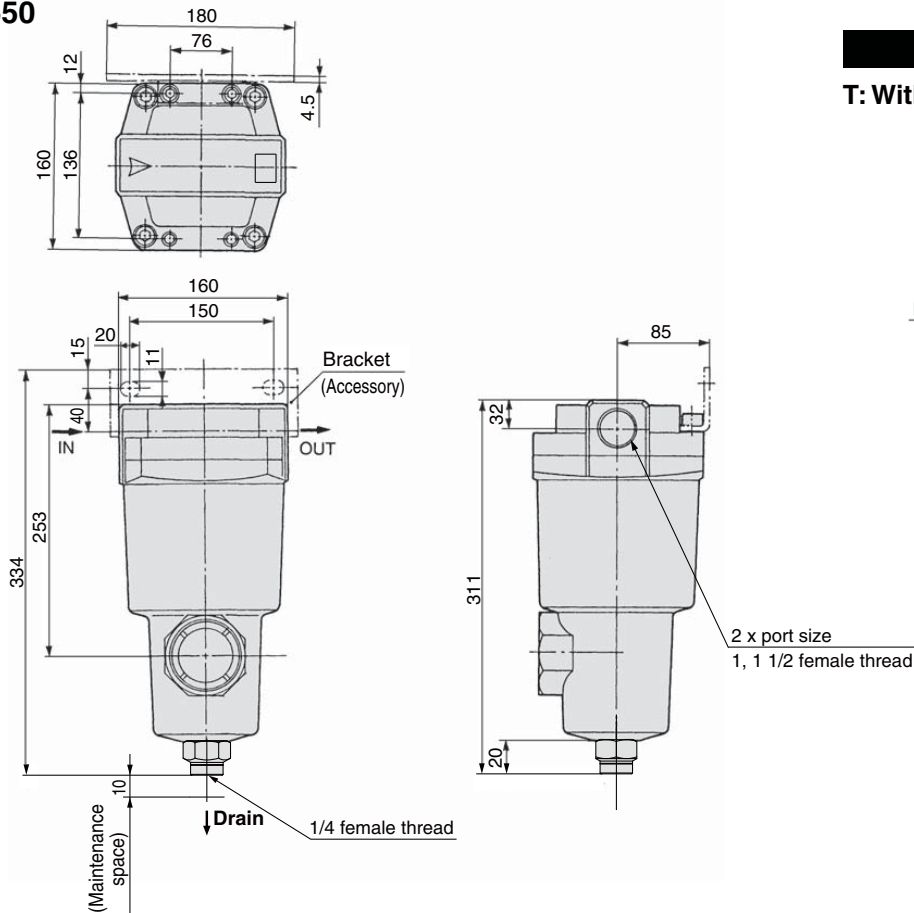

**Option**  
T: With element service indicator

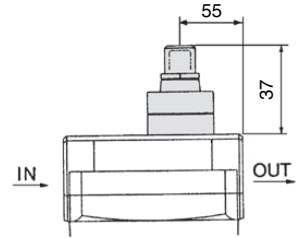

**10-AM850**

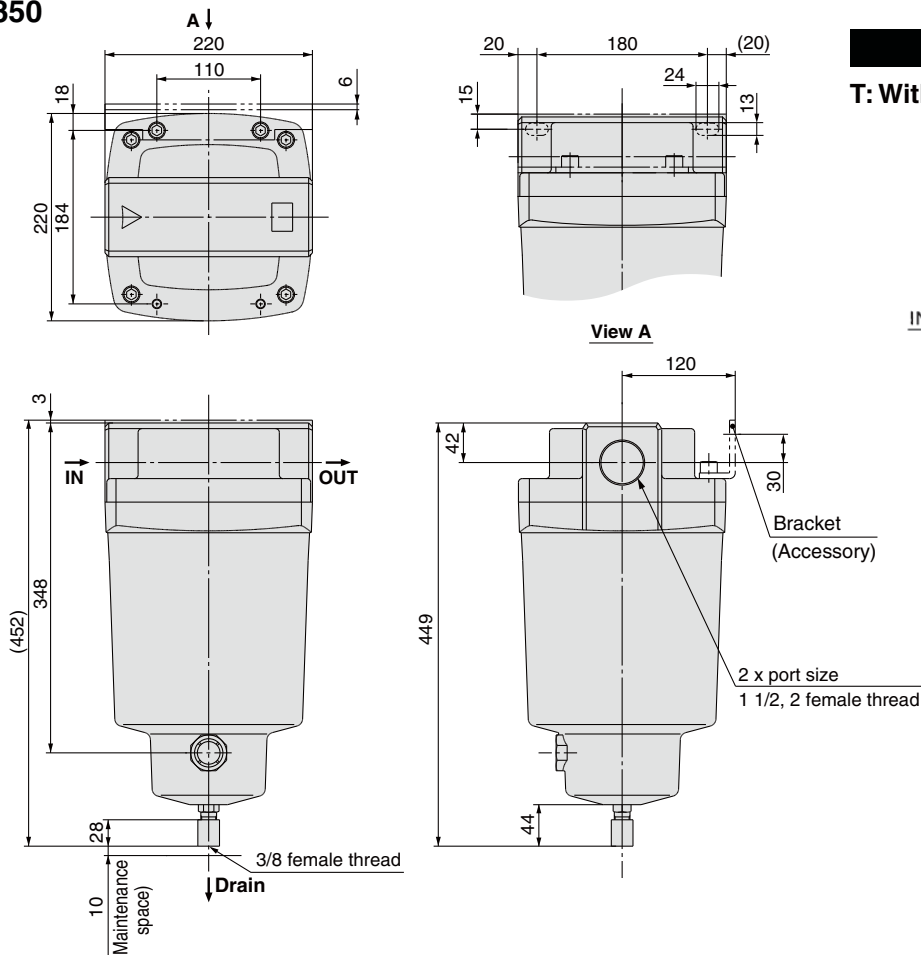

**Option**  
T: With element service indicator

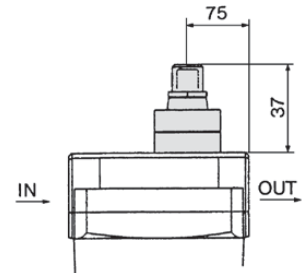

Directional Control Valves
Air Cylinders
Rotary Actuators
Air Grippers
Air Preparation Equipment
Modular F. R.
Pressure Control Equipment
Fittings & Tubing
Flow Control Equipment
Pressure Switches/ Pressure Sensors

# Series 10-AMD

## Micro Mist Separator

RoHS

Can separate and remove aerosol state oil mist in compressed air and remove particles such as carbon or dust of more than 0.01  $\mu\text{m}$ .  
Use this product as a pre-filter for compressed air for precision instruments or clean room requiring higher clean air.

Modular connection is possible with 10-AMD150C to 550C.  
(For details, refer to page 1001.)



10-AMD150C to 550C    10-AMD650/850

### Model

Model	10-AMD150C	10-AMD250C	10-AMD350C	10-AMD450C	10-AMD550C	10-AMD650	10-AMD850
Rated flow (L/min [ANR]) <small>Note)</small>	200	500	1000	2000	3700	6000	12000
Port size	1/8, 1/4	1/4, 3/8	3/8, 1/2	1/2, 3/4	3/4, 1	1, 1 1/2	1 1/2, 2
Weight (kg)	0.38	0.55	0.9	1.4	2.1	4.2	10.5

Note) Maximum flow capacity at 0.7 MPa.

Maximum flow capacity varies depending on the operating pressure.

Refer to Flow Rate Characteristics (page 976) and Max. Flow Capacity Line (page 975).

### Specifications

Fluid	Compressed air
Max. operating pressure	1.0 MPa
Min. operating pressure*	0.05 MPa
Proof pressure	1.5 MPa
Ambient and fluid temperature	5 to 60°C
Nominal filtration rating	0.01 $\mu\text{m}$ (Filtration efficiency: 99.9%)
Oil mist density at outlet	Max. 0.1 mg/m <sup>3</sup> [ANR] <sup>*1</sup> (Before saturated with oil, less than 0.01 mg/m <sup>3</sup> [ANR] $\approx$ 0.008 ppm)
Element replacement period	2 years or when pressure drop reached 0.1 MPa
Cleanliness class (ISO class)	Class 3

\* Oil mist density at 30 mg/m<sup>3</sup> [ANR] blown out by compressor.

### Accessory

Applicable model	10-AMD150C	10-AMD250C	10-AMD350C	10-AMD450C	10-AMD550C	10-AMD650	10-AMD850
Bracket assembly (with 2 mounting screws)	10-AM-BM101	10-AM-BM102	10-AM-BM103	10-AM-BM104	10-AM-BM105	10-BM56	10-BM57

### ⚠ Caution

Be sure to read this before handling.  
Refer to page 1382 for Safety Instructions and pages 1064 to 1066 for Air Preparation Equipment Precautions.



### How to Order

#### 10-AMD150C to 550C

**10-AMD 550C - [ ] 10 [ ] - J [ ]**

Clean series

Body size

150C
250C
350C
450C
550C

Thread type

Symbol	Type
Nil	Rc
F	G
N	NPT

Port size

Symbol	Size	Applicable body size				
		150C	250C	350C	450C	550C
01	1/8	●				
02	1/4	●	●			
03	3/8		●	●		
04	1/2			●	●	
06	3/4				●	●
10	1					●

Option

Symbol	Description
Nil	—
F	Rubber material: Fluororubber*3
H	For medium air pressure (1.6 MPa)
R	IN-OUT reversal direction*3
T	With element service indicator*3

\*3 Combination of T and F or H is not available.

Drain guide\*2 1/4 female thread

\*2 Drain piping and piping for a stop valve such as ball valve are required.

Accessory

Symbol	Description
Nil	—
B	Bracket *1

\*1 Bracket is included (but not assembled).

Directional Control Valves

Air Cylinders

Rotary Actuators

Air Grippers

Air Preparation Equipment

Modular F. R.

Pressure Control Equipment

Fittings & Tubing

Flow Control Equipment

Pressure Switches/ Pressure Sensors

### Options

#### Symbol F: Rubber material: Fluororubber

Fluororubber is used for the parts such as O-ring and gasket.

#### Symbol H: For medium air pressure (1.6 MPa)

Can be used up to 1.6 MPa at maximum.

#### Symbol R: IN-OUT reversal direction

Air flow direction is changed to right to left.  
(Air flow direction of the standard: Left to right.)

#### Symbol T: With element service indicator

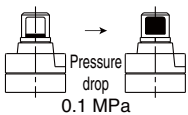

Saturation of the element can be observed visually.



**How to Order**



**10-AMD650/850**



Clean series

**Body size**

650
850

**Thread type**

Symbol	Type
Nil	Rc
F	G
N	NPT

**Port size**

Symbol	Size	Applicable body size	
		650	850
10	1	●	—
14	1 1/2	●	●
20	2	—	●

**Option**

Symbol	Description
Nil	—
R	IN-OUT reversal direction
T	With element service indicator

**Drain guide** \*2 1/4 female thread (10-AMD650),  
3/8 female thread (10-AMD850)

\*2 Drain piping and piping for a stop valve such as ball valve are required.

**Accessory**

Symbol	Description
Nil	—
B	Bracket *1

\*1 Bracket is included (but not assembled).

**Model Selection**

Select a model in accordance with the following procedure taking the inlet pressure and the maximum flow capacity into consideration.  
(Example) Inlet pressure: 0.6 MPa

Maximum flow capacity: 5 m<sup>3</sup>/min [ANR]

1. Obtain the intersecting point A of inlet pressure and maximum flow capacity in the graph.
2. The 10-AMD650 is obtained when the max. flow capacity line is above the intersecting point A in the graph.

Note) Make sure to select a model that has the max. flow capacity line above the obtained intersecting point. With a model that has the max. flow capacity line below the obtained intersecting point, the flow rate will be exceeded, thus leading to a problem such as being unable to satisfy the specifications.

**Max. Flow Capacity Line**

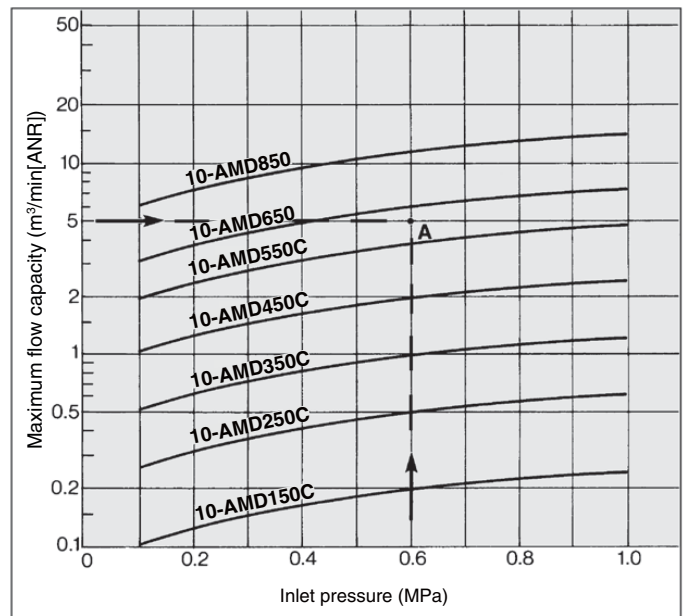

**Flow Rate Characteristics**Select the model under the max. flow capacity line. ( — Element oil saturation - - - - - Initial condition)

Note) Compressed air over max. flow capacity line in the table below may not meet the specifications of the product.

**10-AMD150C**

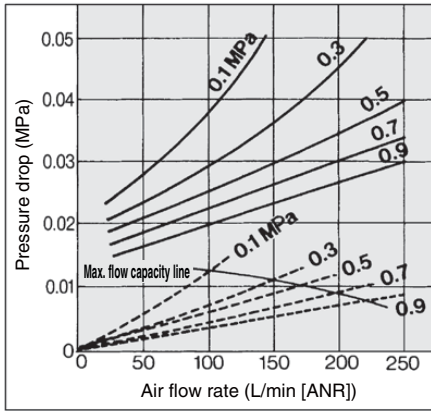

**10-AMD450C**

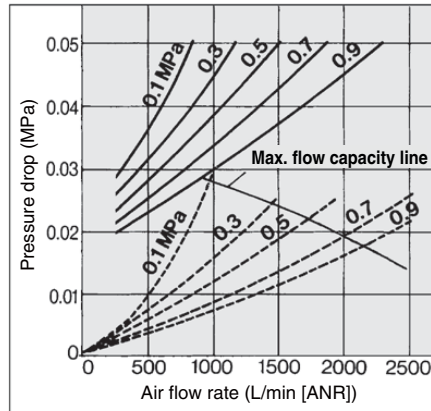

**10-AMD850**

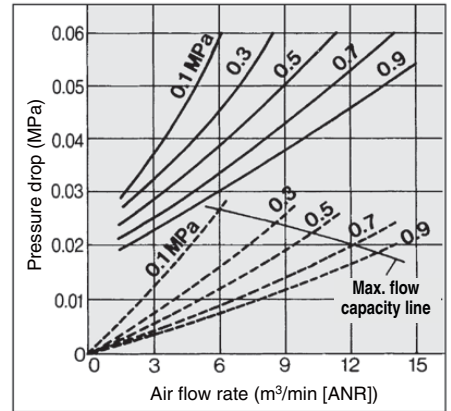

**10-AMD250C**

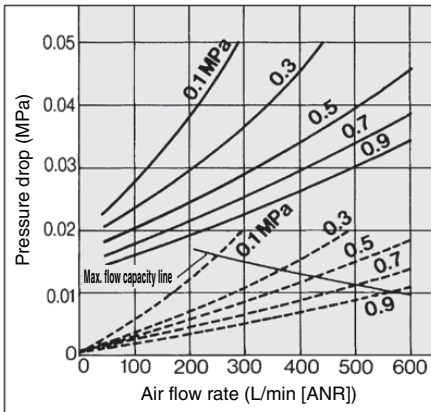

**10-AMD550C**

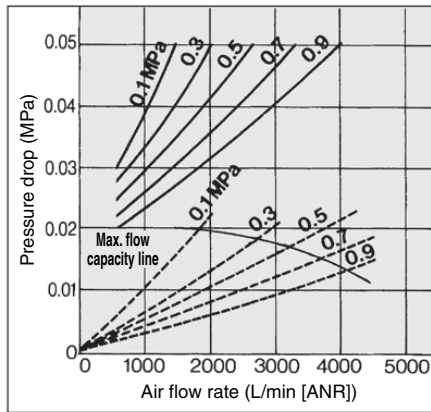

**10-AMD350C**

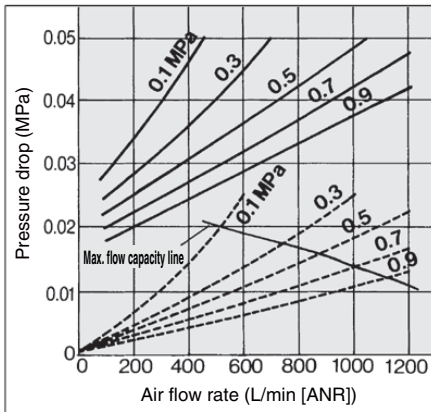

**10-AMD650**

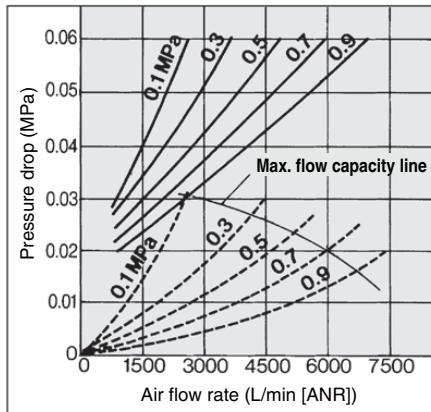

Directional Control Valves

Air Cylinders

Rotary Actuators

Air Grippers

Air Preparation Equipment

Modular F. R.

Pressure Control Equipment

Fittings & Tubing

Flow Control Equipment

Pressure Switches/ Pressure Sensors

**Construction**

**10-AMD150C to 550C, 10-AMD650**

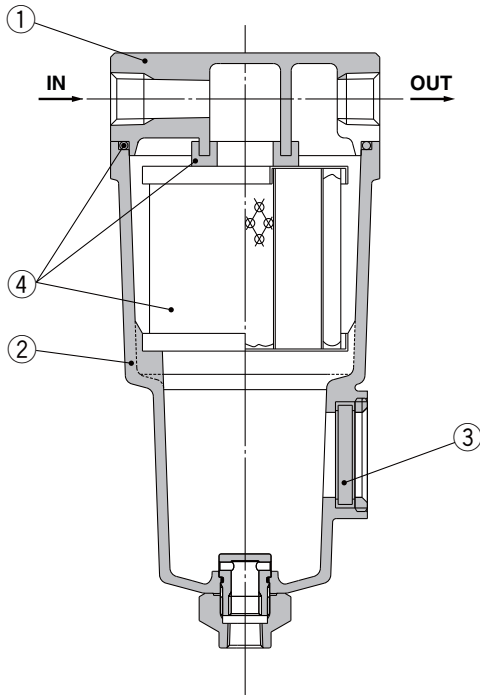

**10-AMD850**

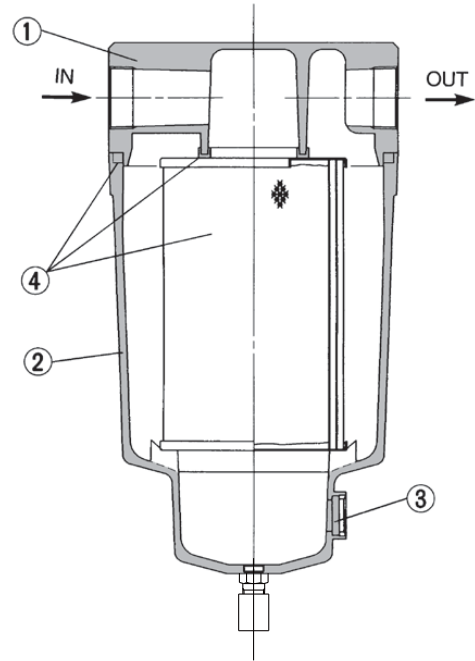

**Component Parts**

No.	Description	Material	Note
1	<b>Body</b>	Aluminum die-casted	Inner/outer surface coating
2	<b>Housing</b>	Aluminum die-casted*	
3	<b>Sight glass</b>	Tempered glass	—

\* The 10-AMD850 is aluminum casted.

Note) Sight glass is indicated in the figure for easy understanding of component parts. However, it differs from the actual construction. Refer to Dimensions on pages 978 to 979 for details.

**Replacement Parts**

No.	Description	Material	Applicable model	Model						
				10-AMD150C	10-AMD250C	10-AMD350C	10-AMD450C	10-AMD550C	10-AMD650	10-AMD850
4	<b>Element assembly</b>	Glass fiber, others	Except option F	10-AMD-EL150	10-AMD-EL250	10-AMD-EL350	10-AMD-EL450	10-AMD-EL550	10-AMD-EL650	10-AMD-EL850
			For option F	10-AMD-EL150-F	10-AMD-EL250-F	10-AMD-EL350-F	10-AMD-EL450-F	10-AMD-EL550-F	—	—

- Element assembly: With gasket (1 pc.) and O-ring (1 pc.)
- Refer to How to Order Bowl Assembly on page 1002.

**Dimensions**

**10-AMD150C to 550C**

**Option**

**T: With element service indicator**

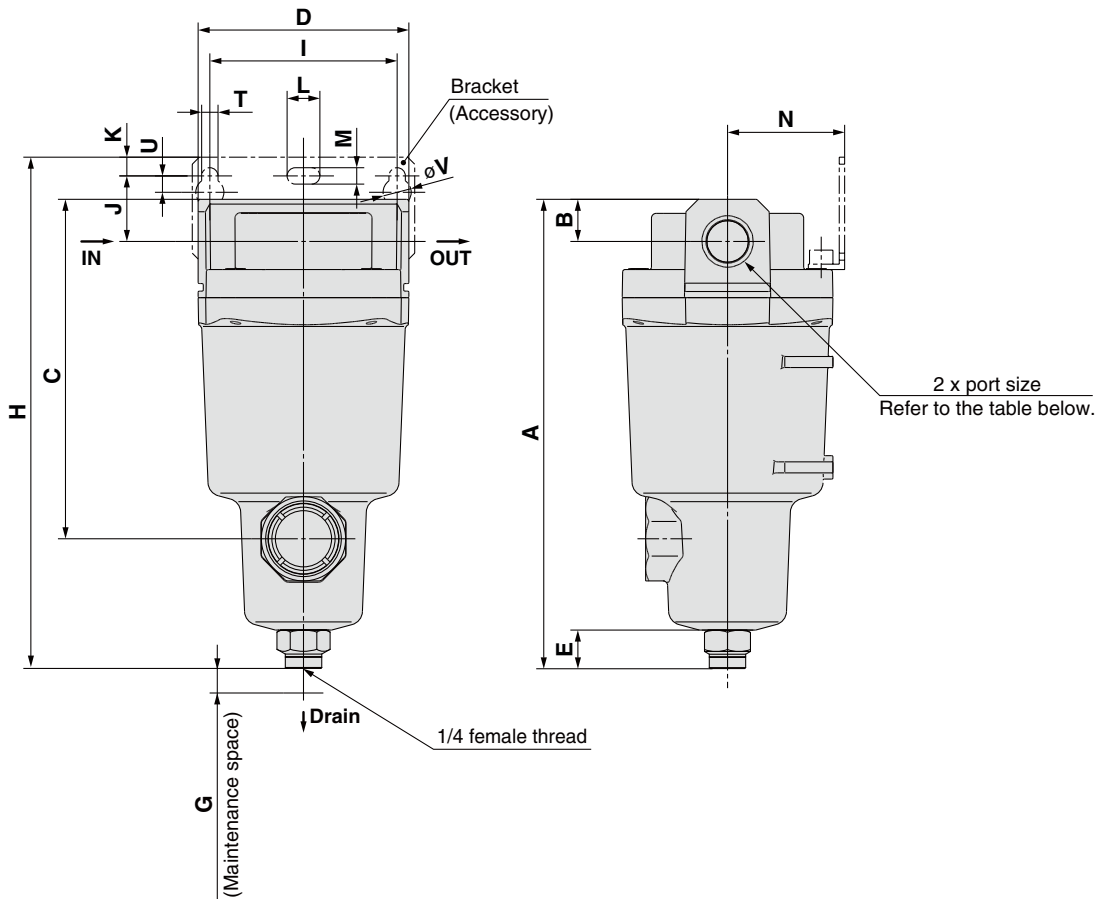
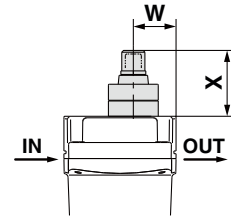
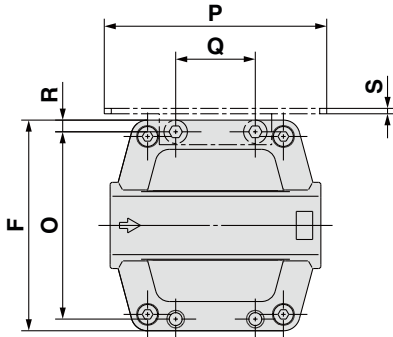

Model	Port size	A	B	C	D	E	F	G	Bracket related dimensions											Element service indicator related dimensions					
									H	I	J	K	T	U	L	M	V	N	O	P	Q	R	S	W	X
10-AMD150C	1/8, 1/4	158	10	99	63	20	63	10	173	56	20	5	6	6	12	6	10	35	54	70	26	4.5	1.6	24	37
10-AMD250C	1/4, 3/8	172	14	113	76	20	76	10	190	66	24	8	6	6	12	6	10	40	66	80	28	5	2	27	37
10-AMD350C	3/8, 1/2	204	18	145	90	20	90	10	222	80	28	8	7	7	14	7	12	50	80	95	34	5	2.3	32	37
10-AMD450C	1/2, 3/4	225	20	166	106	20	106	10	246	90	31	10	9	9	18	9	15	55	88	111	50	9	3.2	37	37
10-AMD550C	3/4, 1	259	24	200	122	20	122	15	278	100	33	10	9	9	18	9	15	65	102	126	60	10	3.2	39	37

Directional Control Valves

Air Cylinders

Rotary Actuators

Air Grippers

Air Preparation Equipment

Modular F. R.

Pressure Control Equipment

Fittings & Tubing

Flow Control Equipment

Pressure Switches/ Pressure Sensors

**Dimensions**

**10-AMD650**

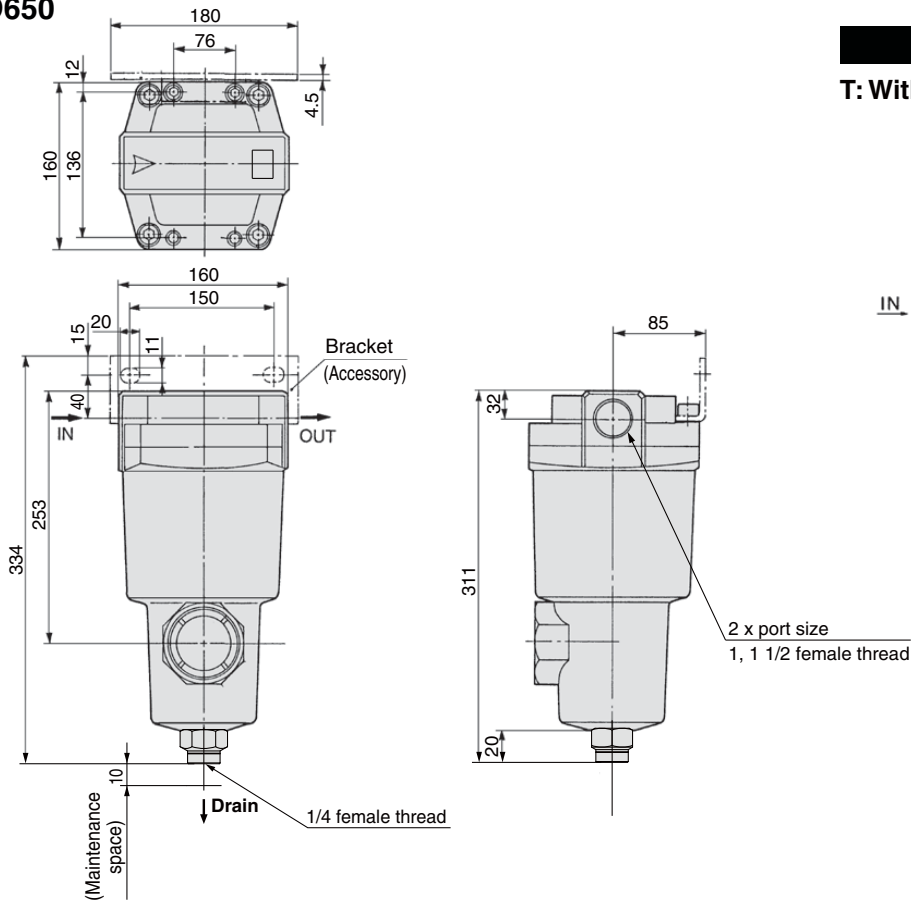

**Option**

**T: With element service indicator**

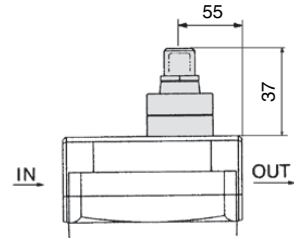

**10-AMD850**

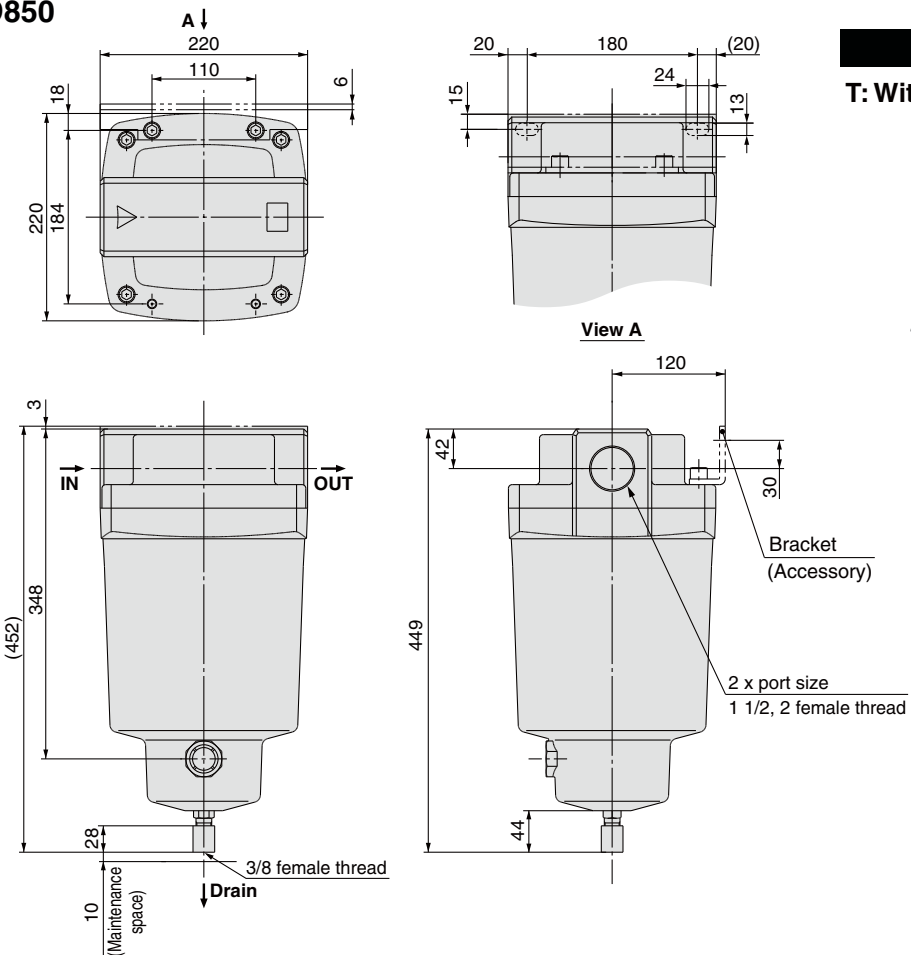

**Option**

**T: With element service indicator**

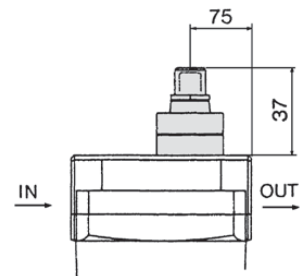

# Series 10-AMH

## Micro Mist Separator with Pre-filter

RoHS

Can separate and remove aerosol state oil mist in compressed air and remove particles such as carbon or dust of more than 0.01 μm.

Use this product as a pre-filter for compressed air for precision instruments or clean room requiring higher clean air.

The conventional pneumatic pressure line, 10-AM series + 10-AMD series have been integrated to achieve a reduction in installation space and in piping labor.

Modular connection is possible with 10-AMH150C to 550C. (For details, refer to page 1001.)



10-AMH150C to 550C      10-AMH650/850

### Model

Model	10-AMH150C	10-AMH250C	10-AMH350C	10-AMH450C	10-AMH550C	10-AMH650	10-AMH850
Rated flow (L/min [ANR]) <small>Note)</small>	200	500	1000	2000	3700	6000	12000
Port size	1/8, 1/4	1/4, 3/8	3/8, 1/2	1/2, 3/4	3/4, 1	1, 1 1/2	1 1/2, 2
Weight (kg)	0.38	0.55	0.9	1.4	2.1	4.2	10.5

Note) Maximum flow capacity at 0.7 MPa.

Maximum flow capacity varies depending on the operating pressure.

Refer to Flow Rate Characteristics (page 983) and Max. Flow Capacity Line below.

### Specifications

Fluid	Compressed air
Max. operating pressure	1.0 MPa
Min. operating pressure*	0.05 MPa
Proof pressure	1.5 MPa
Ambient and fluid temperature	5 to 60°C
Nominal filtration density	0.01 μm (Filtration efficiency: 99.9%)
Oil mist density at outlet	Max. 0.1 mg/m <sup>3</sup> [ANR]* (Before saturated with oil, less than 0.01 mg/m <sup>3</sup> [ANR] ≈0.008 ppm)
Element replacement period	2 years or when pressure drop reached 0.1 MPa
Cleanliness class (ISO class)	Class 3

\* Oil mist density at 30 mg/m<sup>3</sup> [ANR] blown out by compressor.

### Accessory

Applicable model	10-AMH150C	10-AMH250C	10-AMH350C	10-AMH450C	10-AMH550C	10-AMH650	10-AMH850
Bracket assembly (with 2 mounting screws)	10-AM-BM101	10-AM-BM102	10-AM-BM103	10-AM-BM104	10-AM-BM105	10-BM56	10-BM57

### Model Selection

Select a model in accordance with the following procedure taking the inlet pressure and the maximum flow capacity into consideration.

(Example) Inlet pressure: 0.6 MPa

Maximum flow capacity: 5 m<sup>3</sup>/min [ANR]

1. Obtain the intersecting point A of inlet pressure and maximum flow capacity in the graph.
2. The 10-AMH650 is obtained when the max. flow capacity line is above the intersecting point A in the graph.

Note) Make sure to select a model that has the max. flow capacity line above the obtained intersecting point. With a model that has the max. flow capacity line below the obtained intersecting point, the flow rate will be exceeded, thus leading to a problem such as being unable to satisfy the specifications.

### Max. Flow Capacity Line

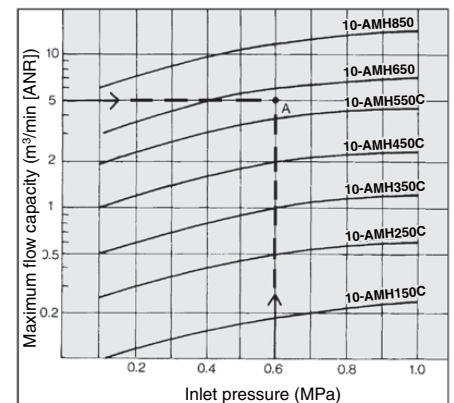

### Caution

Be sure to read this before handling.

Refer to page 1382 for Safety Instructions and pages 1064 to 1066 for Air Preparation Equipment Precautions.

Directional Control Valves

Air Cylinders

Rotary Actuators

Air Grippers

Air Preparation Equipment

Modular F. R.

Pressure Control Equipment

Fittings & Tubing

Flow Control Equipment

Pressure Switches/ Pressure Sensors



## How to Order

### 10-AMH150C to 550C

**10-AMH 550C** - **10** - **J**

Clean series

Body size

150C
250C
350C
450C
550C

Thread type

Symbol	Type
Nil	Rc
F	G
N	NPT

Port size

Symbol	Size	Applicable body size				
		150C	250C	350C	450C	550C
01	1/8	●				
02	1/4	●	●			
03	3/8		●	●		
04	1/2			●	●	
06	3/4				●	●
10	1					●

Option

Symbol	Description
Nil	—
F	Rubber material: Fluororubber*3
H	For medium air pressure (1.6 MPa)*3
R	IN-OUT reversal direction
T	With element service indicator*3

\*3 Combination of T and F or H is not available.

Drain guide\*2 1/4 female thread

\*2 Drain piping and piping for a stop valve such as ball valve are required.

Accessory

Symbol	Description
Nil	—
B	Bracket *1

\*1 Bracket is included (but not assembled).

## Options

### Symbol F: Rubber material: Fluororubber

Fluororubber is used for the parts such as O-ring and gasket.

### Symbol H: For medium air pressure (1.6 MPa)

Can be used up to 1.6 MPa at maximum.

### Symbol R: IN-OUT reversal direction

Air flow direction is changed to right to left.  
(Air flow direction of the standard: Left to right.)

### Symbol T: With element service indicator

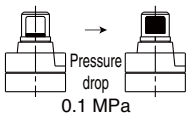

Saturation of the element can be observed visually.



**How to Order**

**10-AMH650/850**

**10-AMH 650 - 10 - J**

Clean series

Body size

650
850

Thread type

Symbol	Type
Nil	Rc
F	G
N	NPT

Port size

Symbol	Size	Applicable body size	
		650	850
10	1	●	—
14	1 1/2	●	●
20	2	—	●

Option

Symbol	Description
Nil	—
R	IN-OUT reversal direction
T	With element service indicator

Drain guide \*2 1/4 female thread (10-AMH650), 3/8 female thread (10-AMH850)

\*2 Drain piping and piping for a stop valve such as ball valve are required.

Accessory

Symbol	Description
Nil	—
B	Bracket *1

\*1 Bracket is included (but not assembled).

Directional Control Valves

Air Cylinders

Rotary Actuators

Air Grippers

Air Preparation Equipment

Modular F. R.

Pressure Control Equipment

Fittings & Tubing

Flow Control Equipment

Pressure Switches/ Pressure Sensors



**Flow Rate Characteristics**/Select the model under the max. flow capacity line. ( — Element oil saturation - - - - Initial condition)

Note) Compressed air over max. flow capacity line in the table below may not meet the specifications of the product.

**10-AMH150C**

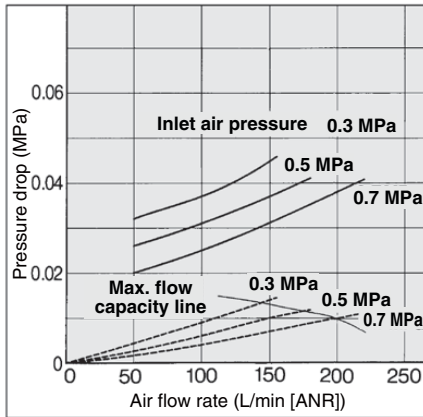

**10-AMH450C**

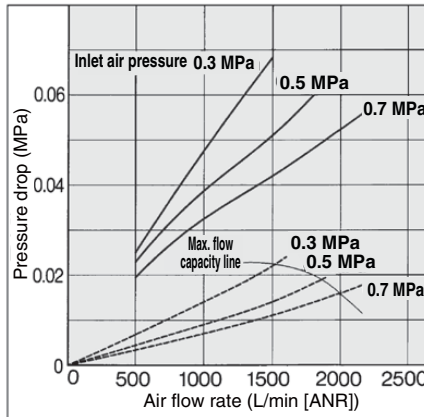

**10-AMH850**

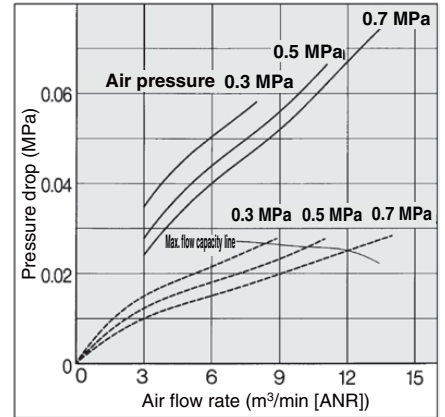

**10-AMH250C**

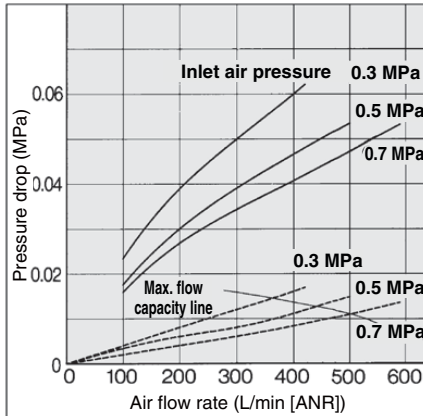

**10-AMH550C**

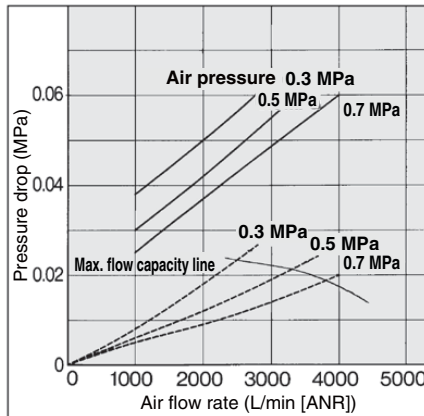

**10-AMH350C**

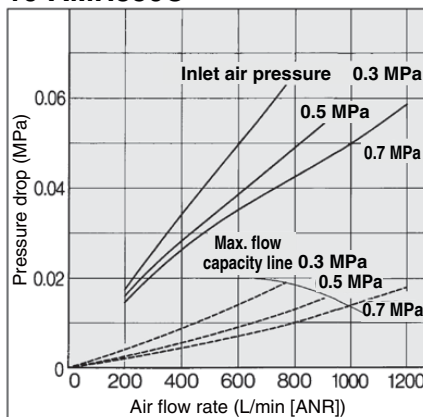

**10-AMH650**

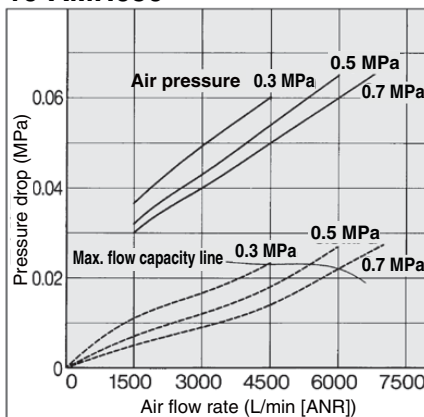

**Construction**

**10-AMH150C to 550C, 10-AMH650**

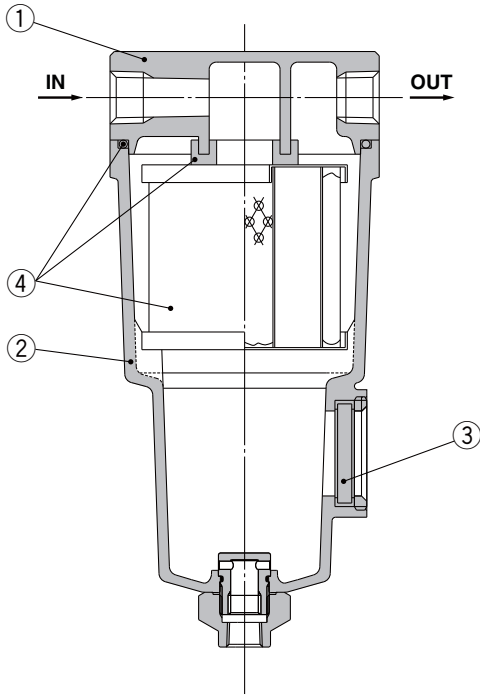

**10-AMH850**

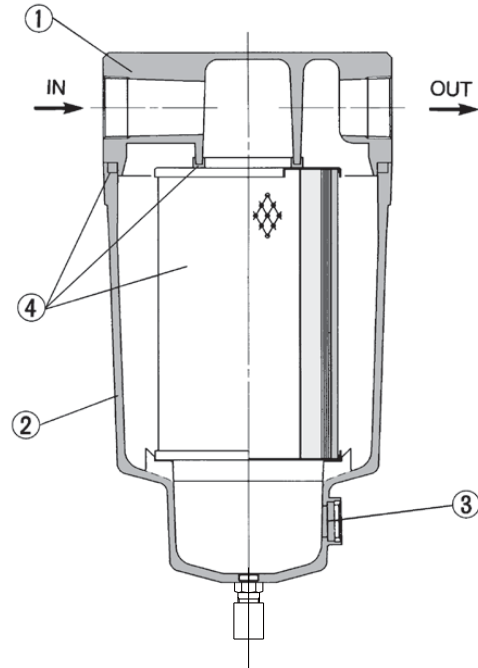

**Component Parts**

No.	Description	Material	Note
1	<b>Body</b>	Aluminum die-casted	Inner/outer
2	<b>Housing</b>	Aluminum die-casted*	surface coating
3	<b>Sight glass</b>	Tempered glass	—

\* The 10-AMH850 is aluminum casted.

Note) Sight glass is indicated in the figure for easy understanding of component parts. However, it differs from the actual construction. Refer to Dimensions on pages 985 to 986 for details.

**Replacement Parts**

No.	Description	Material	Applicable model	Model						
				10-AMH150C	10-AMH250C	10-AMH350C	10-AMH450C	10-AMH550C	10-AMH650	10-AMH850
4	<b>Element assembly</b>	Glass fiber, others	Except option F	10-AMH-EL150	10-AMH-EL250	10-AMH-EL350	10-AMH-EL450	10-AMH-EL550	10-AMH-EL650	10-AMH-EL850
			For option F	10-AMH-EL150-F	10-AMH-EL250-F	10-AMH-EL350-F	10-AMH-EL450-F	10-AMH-EL550-F	—	—

- Element assembly: With gasket (1 pc.) and O-ring (1 pc.)
- Refer to How to Order Bowl Assembly on page 1002.

Directional Control Valves

Air Cylinders

Rotary Actuators

Air Grippers

Air Preparation Equipment

Modular F. R.

Pressure Control Equipment

Fittings & Tubing

Flow Control Equipment

Pressure Switches/ Pressure Sensors

**Dimensions**

**10-AMH150C to 550C**

**Option**

**T: With element service indicator**

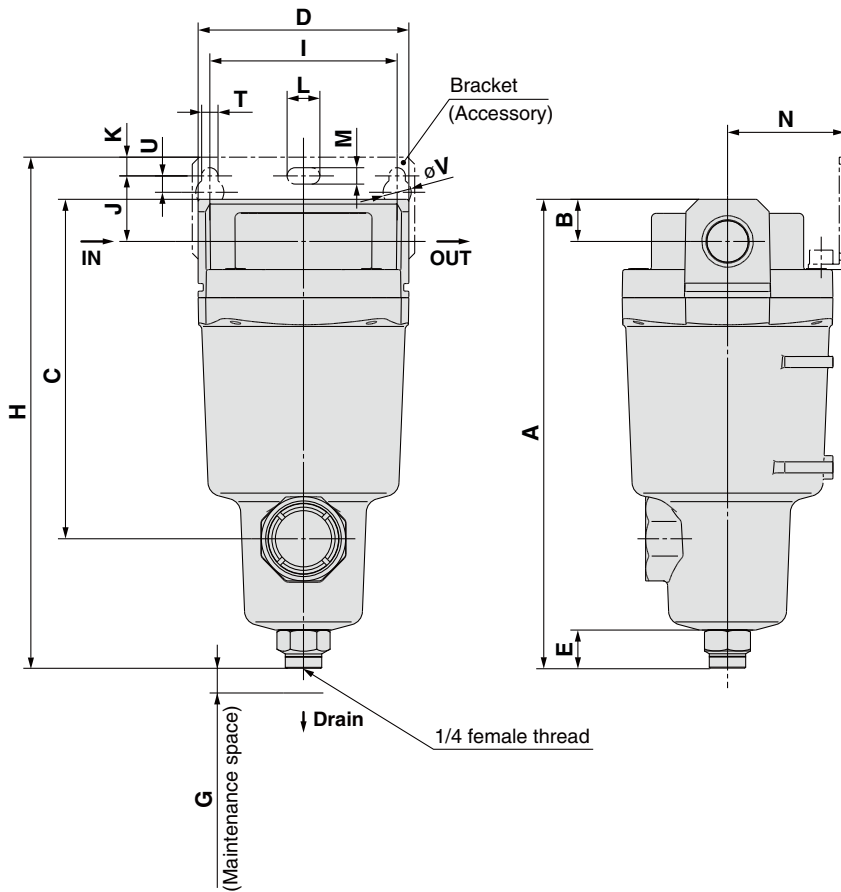
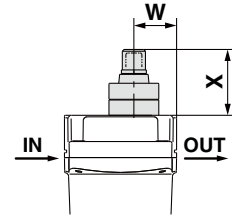
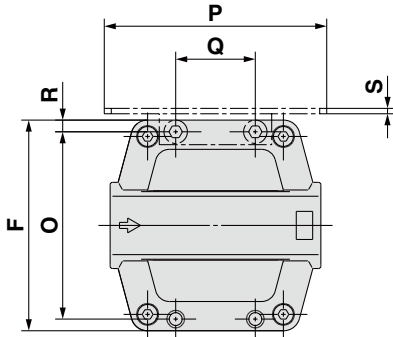

(mm)

Model	Port size	A	B	C	D	E	F	G	Bracket related dimensions													Element service indicator related dimensions			
									H	I	J	K	T	U	L	M	V	N	O	P	Q	R	S	W	X
10-AMH150C	1/8, 1/4	158	10	99	63	20	63	10	173	56	20	5	6	6	12	6	10	35	54	70	26	4.5	1.6	24	37
10-AMH250C	1/4, 3/8	172	14	113	76	20	76	10	190	66	24	8	6	6	12	6	10	40	66	80	28	5	2	27	37
10-AMH350C	3/8, 1/2	204	18	145	90	20	90	10	222	80	28	8	7	7	14	7	12	50	80	95	34	5	2.3	32	37
10-AMH450C	1/2, 3/4	225	20	166	106	20	106	10	246	90	31	10	9	9	18	9	15	55	88	111	50	9	3.2	37	37
10-AMH550C	3/4, 1	259	24	200	122	20	122	15	278	100	33	10	9	9	18	9	15	65	102	126	60	10	3.2	39	37

**Dimensions**

**10-AMH650**

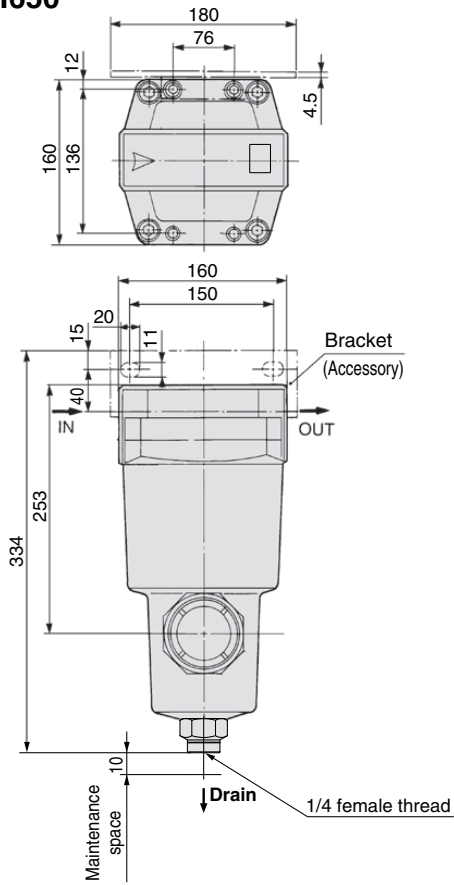

**Option**  
T: With element service indicator

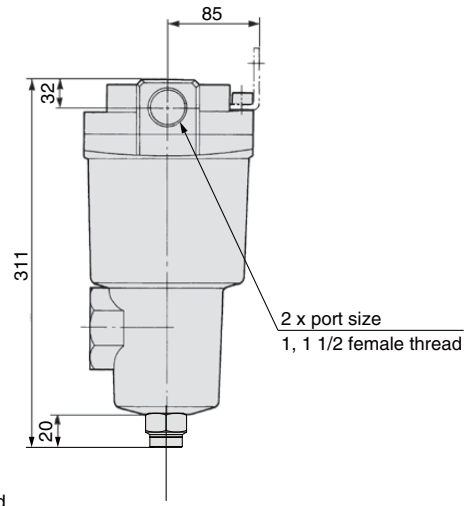
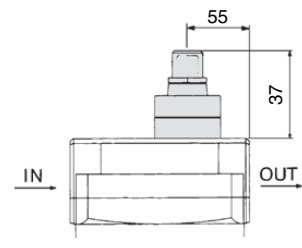

**10-AMH850**

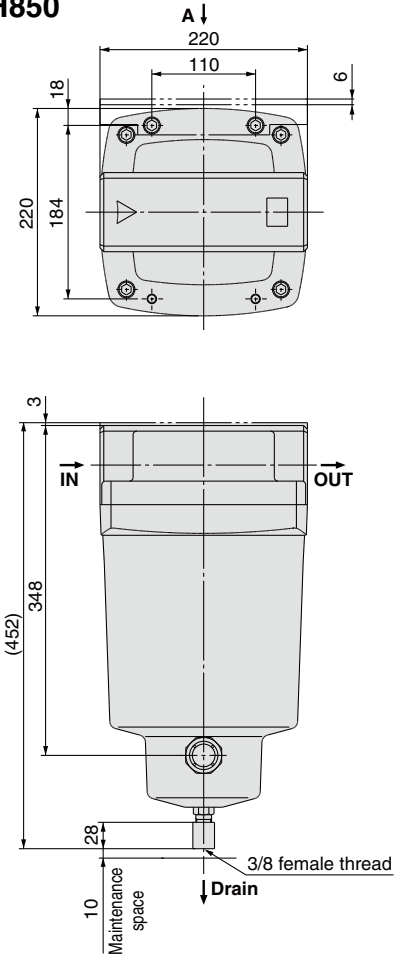

**Option**  
T: With element service indicator

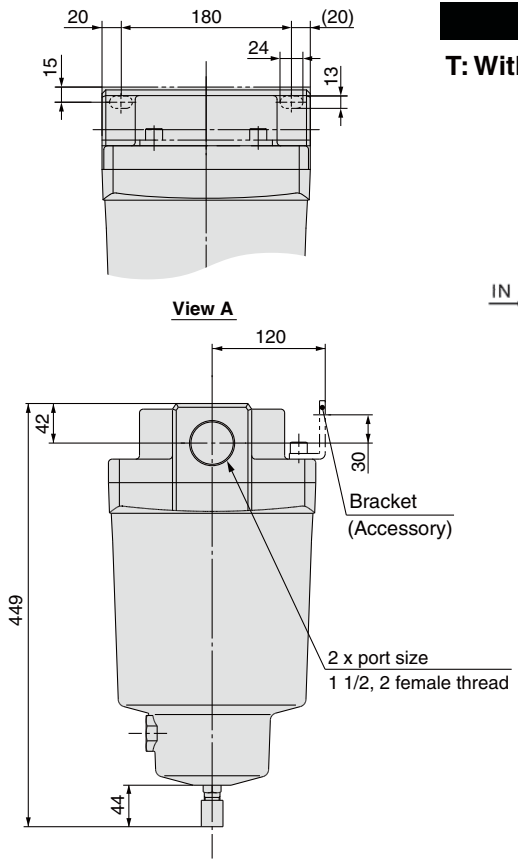
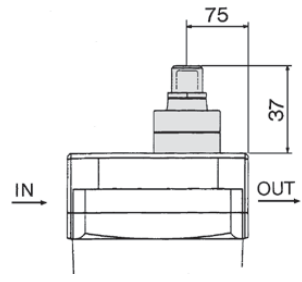

Directional Control Valves
Air Cylinders
Rotary Actuators
Air Grippers
Air Preparation Equipment
Modular F. R.
Pressure Control Equipment
Fittings & Tubing
Flow Control Equipment
Pressure Switches/ Pressure Sensors

# Series 10-AME

Super Mist Separator

RoHS

Can separate and adsorb aerosol state fine oil particles in compressed air and change the oil lubricating compressed air to oilless air or equivalent.

Use this product for filtration of compressed air requiring higher clean air for painting lines, compressed air for clean rooms and/or equipment where oils must be avoided.

Indicates the replacement time of the filter element by a color change. Accordingly, the replacement time can be judged visually. (A red color spot indicates the replacement time.)

## ⚠ Caution

By all means the AM series should be used as a pre-filter.

Modular connection is possible with 10-AME150C to 550C. (For details, refer to page 1001.)



10-AME150C to 350C 10-AME450C/550C



10-AME650/850

## Model

Model	10-AME150C	10-AME250C	10-AME350C	10-AME450C	10-AME550C	10-AME650	10-AME850
Rated flow (L/min [ANR]) <small>Note)</small>	200	500	1000	2000	3700	6000	12000
Port size	1/8, 1/4	1/4, 3/8	3/8, 1/2	1/2, 3/4	3/4, 1	1, 1 1/2	1 1/2, 2
Weight (kg)	0.3	0.48	0.8	1.3	2.0	4.2	10.5

Note) Maximum flow capacity at 0.7 MPa.

Maximum flow capacity varies depending on the operating pressure.

Refer to Flow Rate Characteristics (page 990) and Max. Flow Capacity Line (page 990).

## Specifications

Fluid	Compressed air
Max. operating pressure	1.0 MPa
Min. operating pressure	0.05 MPa
Proof pressure	1.5 MPa
Ambient and fluid temperature	5 to 60°C
Nominal filtration rating	0.01 μm (Filtration efficiency: 99.9%)
Cleanliness at outlet	Less than 100 particles of 0.3 μm or larger per cubic foot [Less than 35 particles per 10 liters [ANR]]
Oil mist density at outlet	Max. 0.01 mg/m <sup>3</sup> [ANR] (≈0.008 ppm)
Element replacement period	① Element color indicator (Replace the element when a red color spot occurred on the surface.) ② Even if a red color spot does not appear on the surface, the replacement interval for the element is when the pressure drop reaches 0.1 MPa or after two years of operation, whichever comes first.
Cleanliness class (ISO class)	Class 3

## Accessory

Applicable model	10-AME150C	10-AME250C	10-AME350C	10-AME450C	10-AME550C	10-AME650	10-AME850
Bracket assembly (with 2 mounting screws)	10-AM-BM101	10-AM-BM102	10-AM-BM103	10-AM-BM104	10-AM-BM105	10-BM56	10-BM57

## ⚠ Caution

Be sure to read this before handling. Refer to page 1382 for Safety Instructions and pages 1064 to 1066 for Air Preparation Equipment Precautions.

**How to Order**



**10-AME150C to 550C**

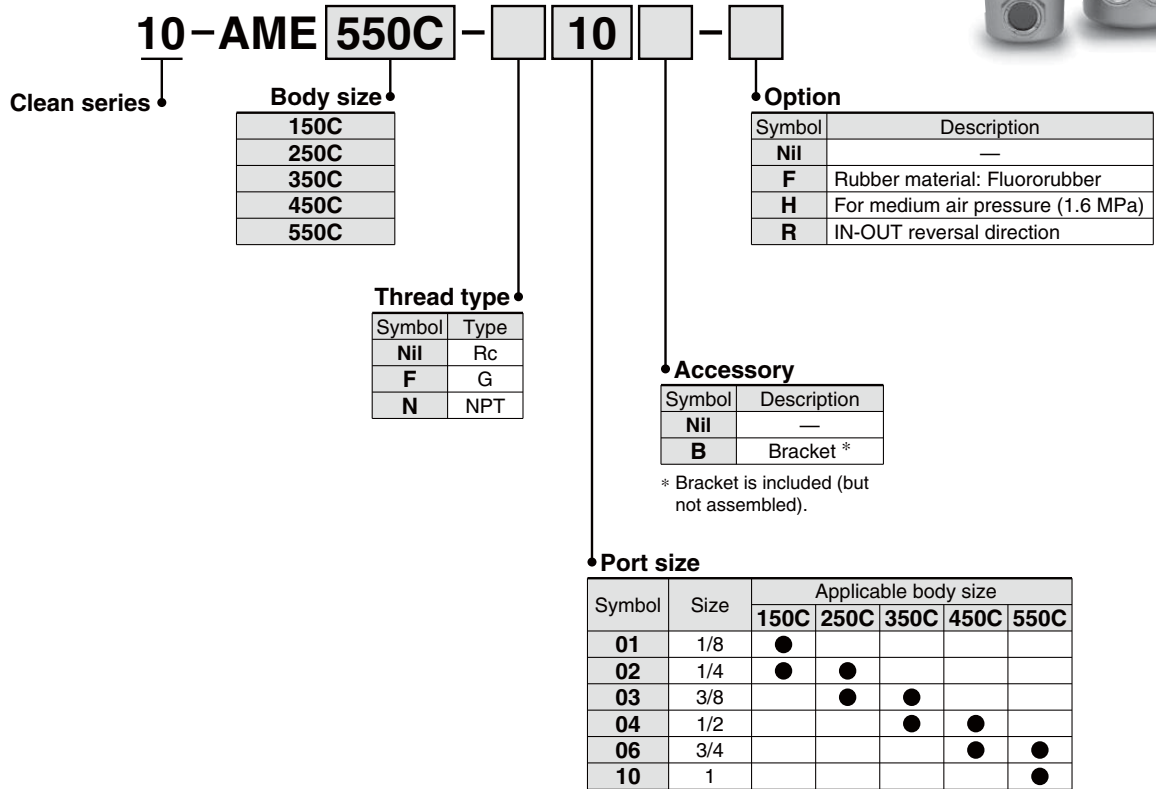

- Directional Control Valves
- Air Cylinders
- Rotary Actuators
- Air Grippers
- Air Preparation Equipment
- Modular F. R.
- Pressure Control Equipment
- Fittings & Tubing
- Flow Control Equipment
- Pressure Switches/ Pressure Sensors

**Options**

**Symbol F: Rubber material: Fluororubber**

Fluororubber is used for the parts such as O-ring and gasket.

**Symbol H: For medium air pressure (1.6 MPa)**

Can be used up to 1.6 MPa at maximum.

**Symbol R: IN-OUT reversal direction**

Air flow direction is changed to right to left.  
(Air flow direction of the standard: Left to right.)

**How to Order**



**10-AME650/850**

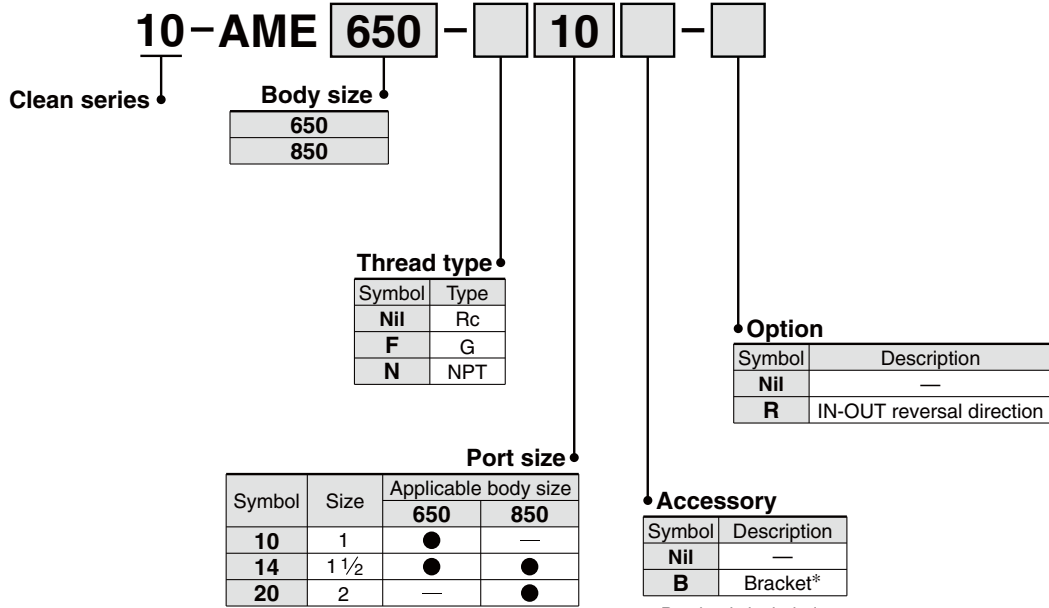

\* Bracket is included (but not assembled).

**Flow Rate Characteristics/Select the model under the max. flow capacity line. (Element initial condition)**

Note) Compressed air over max. flow capacity line line in the table below may not meet the specifications of the product.

**10-AME150C**

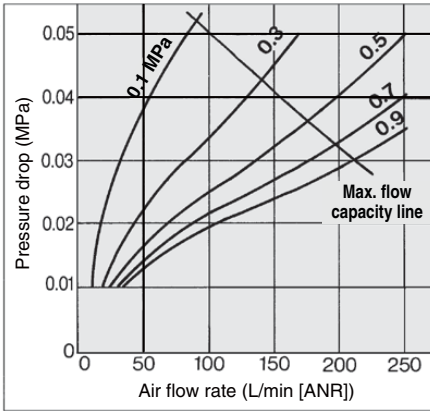

**10-AME450C**

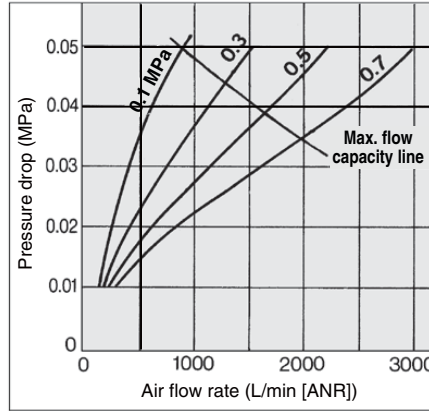

**10-AME650**

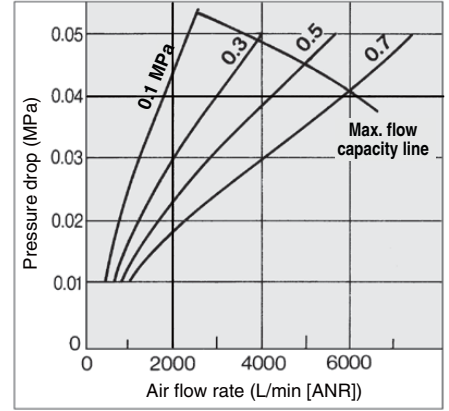

**10-AME250C**

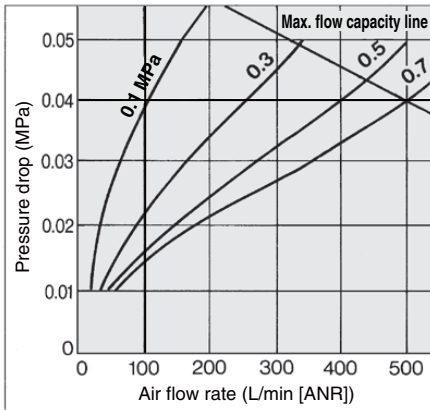

**10-AME550C**

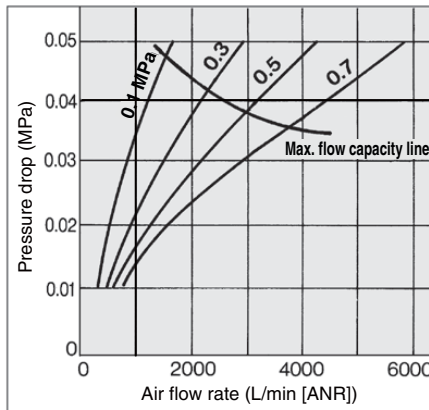

**10-AME850**

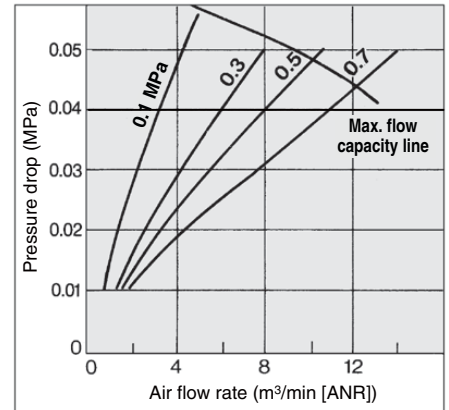

**10-AME350C**

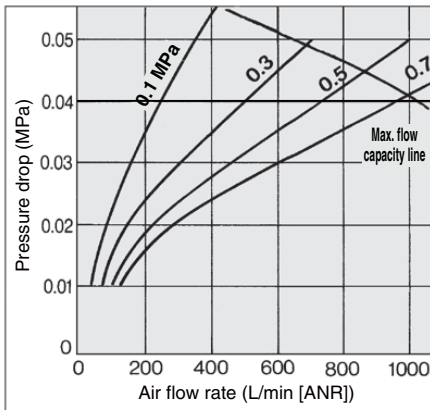

**Model Selection**

Select a model in accordance with the following procedure taking the inlet pressure and the maximum flow capacity into consideration.

(Example) Inlet pressure: 0.6 MPa

Maximum flow capacity: 5 m<sup>3</sup>/min [ANR]

1. Obtain the intersecting point A of inlet pressure and maximum flow capacity in the graph.
2. The 10-AME650 is obtained when the max. flow capacity line is above the intersecting point A in the graph.

Note) Make sure to select a model that has the max. flow capacity line above the obtained intersecting point. With a model that has the max. flow capacity line below the obtained intersecting point, the flow rate will be exceeded, thus leading to a problem such as being unable to satisfy the specifications.

**Max. Flow Capacity Line**

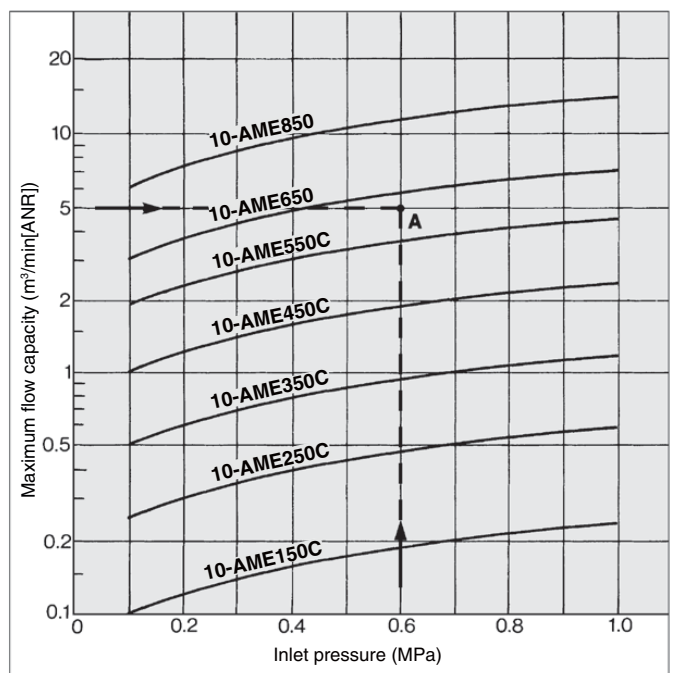

Directional Control Valves

Air Cylinders

Rotary Actuators

Air Grippers

Air Preparation Equipment

Modular F. R.

Pressure Control Equipment

Fittings & Tubing

Flow Control Equipment

Pressure Switches/ Pressure Sensors



**Construction**

**10-AME150C to 550C**

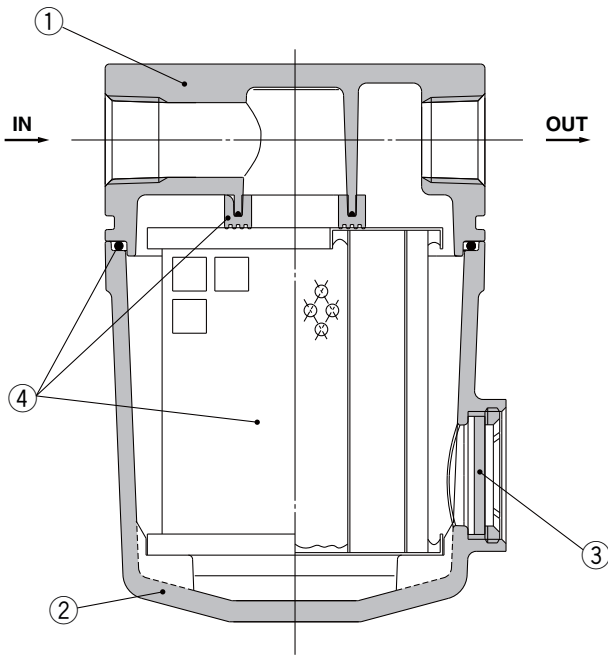

**10-AME650/850**

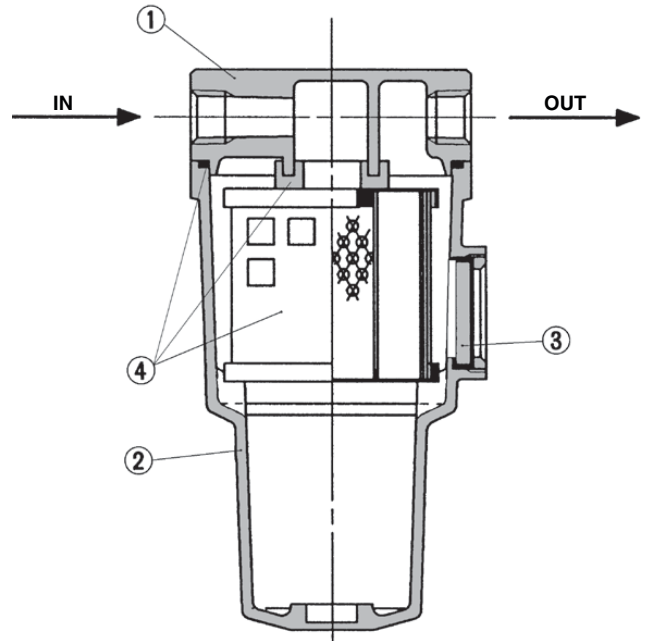

**Component Parts**

No.	Description	Material	Note
1	<b>Body</b>	Aluminum die-casted	Chrome treated
2	<b>Housing</b>	Aluminum die-casted*	Epoxy coating on inner surface
3	<b>Sight glass</b>	Tempered glass	—

\* The 10-AME850 is aluminum casted.

Note) Sight glass is indicated in the figure for easy understanding of component parts. However, it differs from the actual construction. Refer to Dimensions on pages 992 to 993 for details.

**Replacement Parts**

No.	Description	Material	Applicable model	Model						
				10-AME150C	10-AME250C	10-AME350C	10-AME450C	10-AME550C	10-AME650	10-AME850
4	<b>Element assembly</b>	Glass fiber, others	Except option F For option F	10-AME-EL150 10-AME-EL150-F	10-AME-EL250 10-AME-EL250-F	10-AME-EL350 10-AME-EL350-F	10-AME-EL450 10-AME-EL450-F	10-AME-EL550 10-AME-EL550-F	10-AME-EL650	10-AME-EL850

- Element assembly: With gasket (1 pc.) and O-ring (1 pc.)
- Refer to How to Order Bowl Assembly on page 1002.

**Dimensions**

**10-AME150C to 350C**

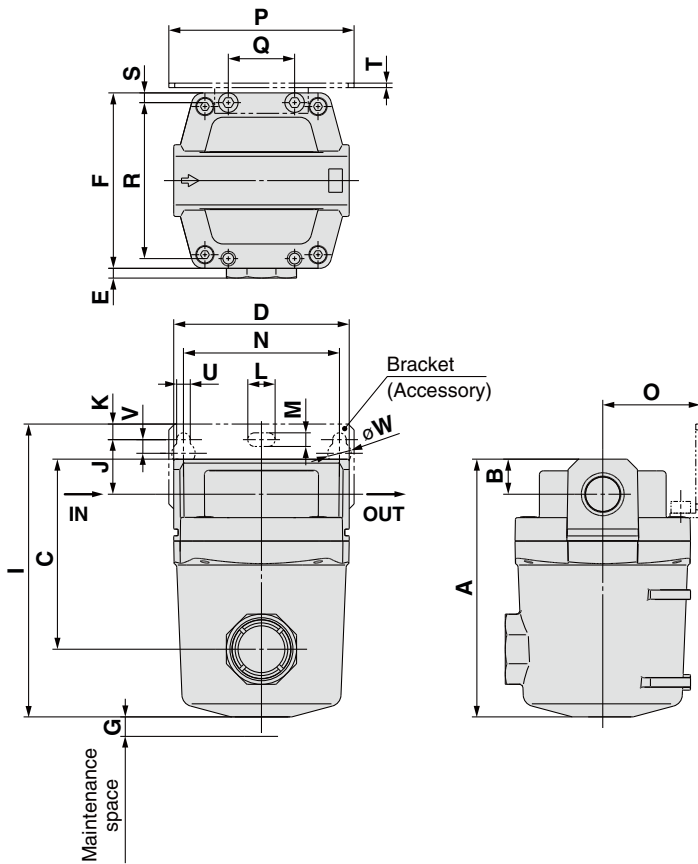

Model	Port size	A	B	C	D	E	F	G	(mm)
<b>10-AME150C</b>	1/8, 1/4	83	10	54	63	7.5	63	10	
<b>10-AME250C</b>	1/4, 3/8	103	14	73	76	5	76	10	
<b>10-AME350C</b>	3/8, 1/2	132	18	98	90	5	90	10	

Model	Bracket related dimensions							
	I	N	J	K	U	V	L	M
<b>10-AME150C</b>	99	56	20	5	6	6	12	6
<b>10-AME250C</b>	121	66	24	8	6	6	12	6
<b>10-AME350C</b>	150	80	28	8	7	7	14	7

Model	Bracket related dimensions						
	W	O	P	Q	R	S	T
<b>10-AME150C</b>	10	35	70	26	54	4.5	1.6
<b>10-AME250C</b>	10	40	80	28	66	5	2
<b>10-AME350C</b>	12	50	95	34	80	5	2.3

**10-AME450C/550C**

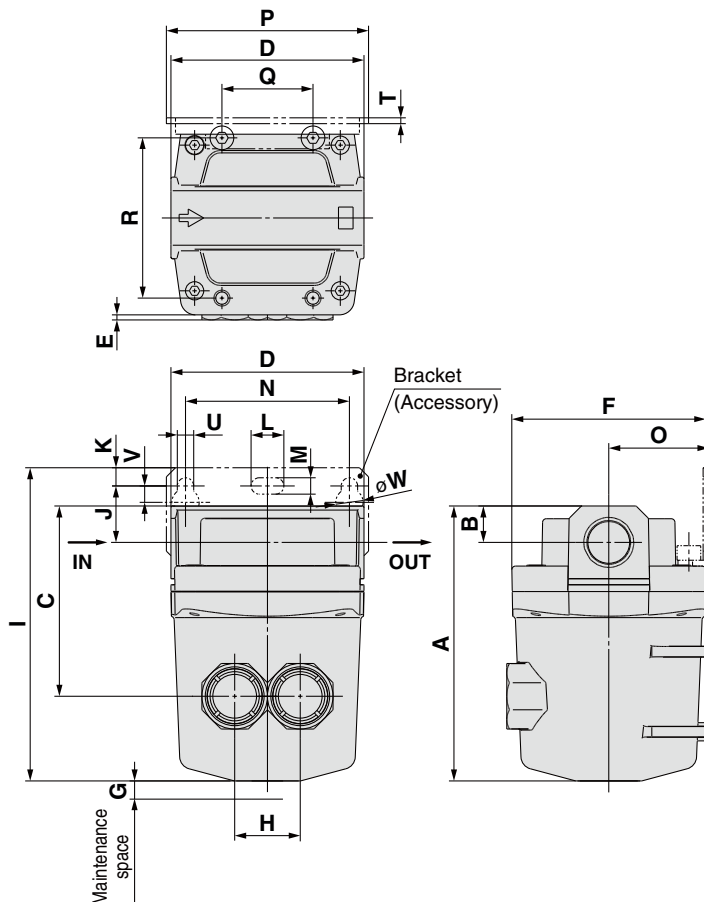

Model	Port size	A	B	C	D	E	F	G	H	(mm)
<b>10-AME450C</b>	1/2, 3/4	151	20	105	106	3	106	10	36	
<b>10-AME550C</b>	3/4, 1	187	24	130	122	3	122	15	44	

Model	Bracket related dimensions							
	I	N	J	K	U	V	L	M
<b>10-AME450C</b>	172	90	31	10	9	9	18	9
<b>10-AME550C</b>	206	100	33	10	9	9	18	9

Model	Bracket related dimensions					
	W	O	P	Q	R	T
<b>10-AME450C</b>	15	55	111	50	88	3.2
<b>10-AME550C</b>	15	65	126	60	102	3.2

Directional Control Valves

Air Cylinders

Rotary Actuators

Air Grippers

Air Preparation Equipment

Modular F. R.

Pressure Control Equipment

Fittings & Tubing

Flow Control Equipment

Pressure Switches/ Pressure Sensors

**Dimensions**

**10-AME650/10-AME850**

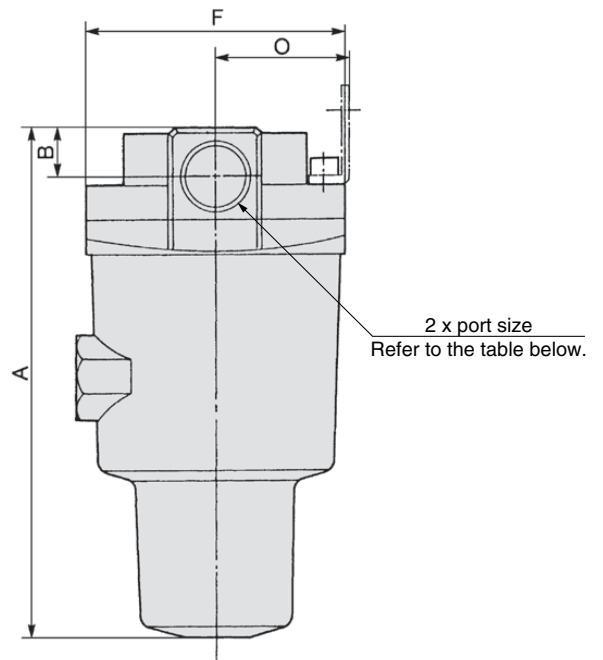
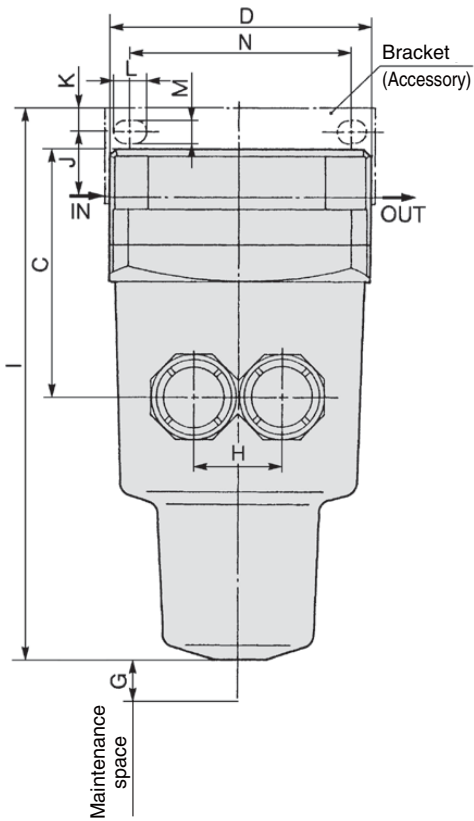
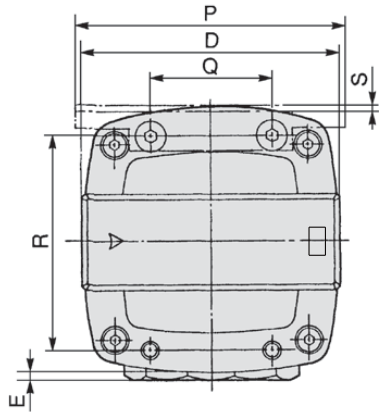

(mm)

Model	Port size	A	B	C	D	E	F	G	H	Bracket related dimensions										
										I	J	K	L	M	N	O	P	Q	R	S
<b>10-AME650</b>	1, 1½	291	32	167	160	—	160	10	66	314	40	15	20	11	150	85	180	76	136	4.5
<b>10-AME850</b>	1½, 2	403	42	235	220	—	220	10	96	406	30	15	24	13	180	120	220	110	184	6

# Series 10-AMF

Odor Removal Filter

RoHS

Efficiently can remove odor in compressed air with an activated carbon element. The unit is designed for use in the area such as a clean room where odors must be avoided.

Can remove odor and gas ingredients in compressed air.

Activated carbon element with large filtration area.

Easy replacement of elements.

Modular connection is possible with 10-AMF150C to 550C.

(For details, refer to page 1001.)



10-AMF150C to 350C 10-AMF450C, 550C



10-AMF650, 850

## Model

Model	10-AMF150C	10-AMF250C	10-AMF350C	10-AMF450C	10-AMF550C	10-AMF650	10-AMF850
Rated flow (L/min [ANR]) <small>Note)</small>	200	500	1000	2000	3700	6000	12000
Port size	1/8, 1/4	1/4, 3/8	3/8, 1/2	1/2, 3/4	3/4, 1	1, 1 1/2	1 1/2, 2
Weight (kg)	0.3	0.48	0.8	1.3	2.0	4.2	10.5

Note) Maximum flow capacity at 0.7 MPa.

Maximum flow capacity varies depending on the operating pressure.

Refer to Flow Rate Characteristics (page 997) and Max. Flow Capacity Line (page 996).

## Specifications

Fluid	Compressed air
Max. operating pressure	1.0 MPa
Min. operating pressure	0.05 MPa
Proof pressure	1.5 MPa
Ambient and fluid temperature	5 to 60°C
Nominal filtration rating	0.01 μm (Filtration efficiency: 99.9%)
Cleanliness at outlet	Less than 100 particles of 0.3 μm or larger per cubic foot [Less than 35 particles per 10 liters [ANR]] (The AME series is required on the inlet side.)
Oil mist density at outlet	Max. 0.004 mg/m <sup>3</sup> [ANR] (=0.0032 ppm) (The AME series is required on the inlet side.)
Element replacement period	1. Replace the element when you smell oil on the outlet side. 2. Even if the deodorization performance is normal, the replacement interval for the element is when the pressure drop reaches 0.1 MPa or after two years of operation, whichever comes first.
Cleanliness class (ISO class)	Class 3

## Accessory (Option)

Applicable model	10-AMF150C	10-AMF250C	10-AMF350C	10-AMF450C	10-AMF550C	10-AMF650	10-AMF850
Bracket assembly (with 2 mounting screws)	10-AM-BM101	10-AM-BM102	10-AM-BM103	10-AM-BM104	10-AM-BM105	10-BM56	10-BM57

## ⚠ Caution

Be sure to read this before handling.  
Refer to page 1382 for Safety Instructions and pages 1064 to 1066 for Air Preparation Equipment Precautions.

Directional Control Valves

Air Cylinders

Rotary Actuators

Air Grippers

Air Preparation Equipment

Modular F. R.

Pressure Control Equipment

Fittings & Tubing

Flow Control Equipment

Pressure Switches/ Pressure Sensors

**How to Order**



**10-AMF150C to 550C**

**10-AMF 550C** - [ ] **10** [ ] - [ ]

• **Body size**

150C
250C
350C
450C
550C

• **Thread type**

Symbol	Type
Nil	Rc
F	G
N	NPT

• **Option**

Symbol	Description
Nil	—
F	Rubber material: Fluororubber
H	For medium air pressure (1.6 MPa)
R	IN-OUT reversal direction

• **Accessory**

Symbol	Description
Nil	—
B	Bracket *

\* Bracket is included (but not assembled).

• **Port size**

Symbol	Size	Applicable body size				
		150C	250C	350C	450C	550C
01	1/8	●				
02	1/4	●	●			
03	3/8		●	●		
04	1/2			●	●	
06	3/4				●	●
10	1					●

**Options**

**Symbol F: Rubber material: Fluororubber**

Fluororubber is used for the parts such as O-ring and gasket.

**Symbol H: For medium air pressure (1.6 MPa)**

Can be used up to 1.6 MPa at maximum.

**Symbol R: IN-OUT reversal direction**

Air flow direction is changed to right to left.  
(Air flow direction of the standard: Left to right.)



### How to Order

#### 10-AMF650 to 850

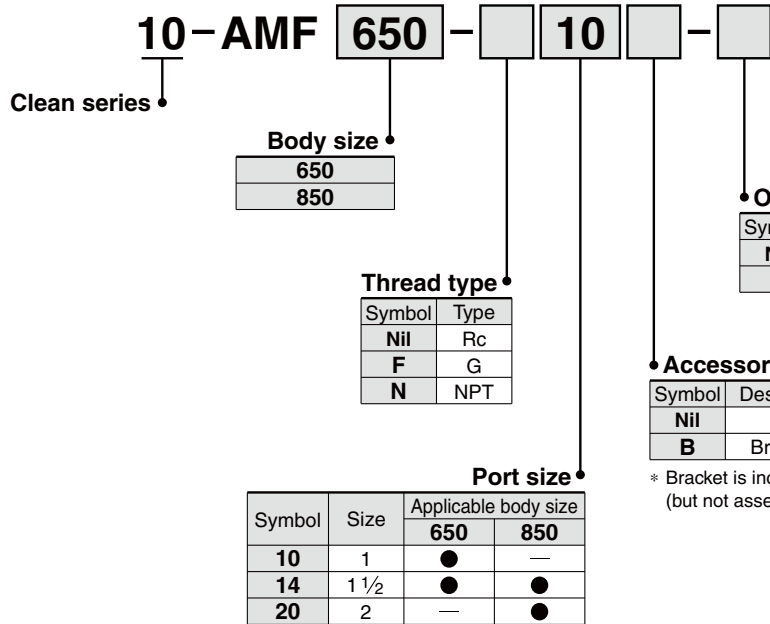

**Option**

Symbol	Description
Nil	—
R	IN-OUT reversal direction

**Accessory**

Symbol	Description
Nil	—
B	Bracket*

\* Bracket is included (but not assembled).

### Model Selection

Select a model in accordance with the following procedure taking the inlet pressure and the maximum flow capacity rate into consideration.  
(Example) Inlet pressure: 0.6 MPa

Maximum flow capacity: 5 m<sup>3</sup>/min [ANR]

1. Obtain the intersecting point A of inlet pressure and maximum flow capacity in the graph.
2. The 10-AMF650 is obtained when the max. flow capacity line is above the intersecting point A in the graph.

Note) Make sure to select a model that has the max. flow capacity line above the obtained intersecting point. With a model that has the max. flow capacity line below the obtained intersecting point, the flow rate will be exceeded, thus leading to a problem such as being unable to satisfy the specifications.

### Max. Flow Capacity Line

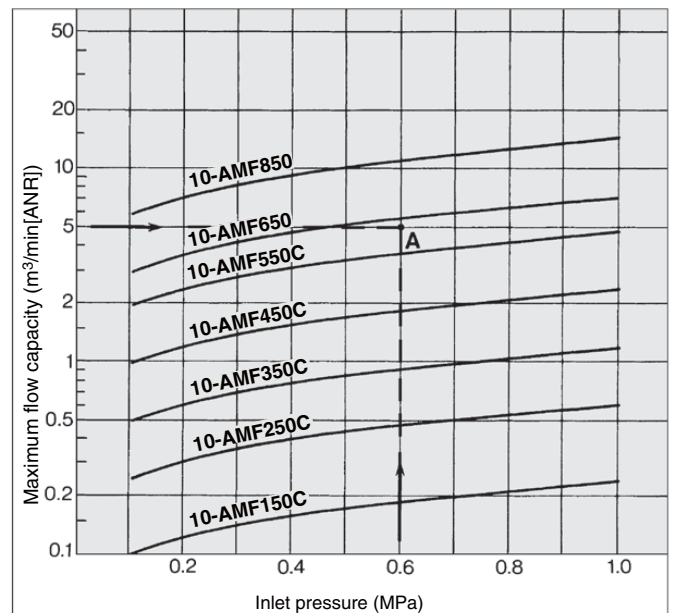

Directional Control Valves

Air Cylinders

Rotary Actuators

Air Grippers

Air Preparation Equipment

Modular F. R.

Pressure Control Equipment

Fittings & Tubing

Flow Control Equipment

Pressure Switches/ Pressure Sensors

**Flow Rate Characteristics**/Select the model under the max. flow capacity line. (Element oil saturation)

Note) Compressed air over max. flow capacity line in the table below may not meet the specifications of the product.

**10-AMF150C**

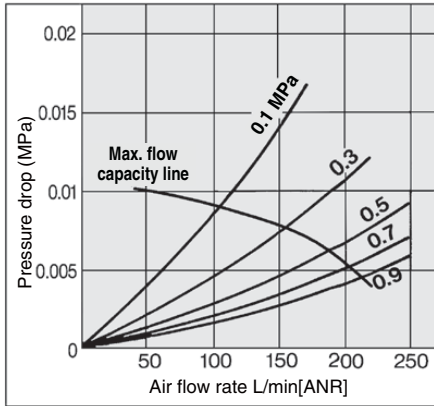

**10-AMF450C**

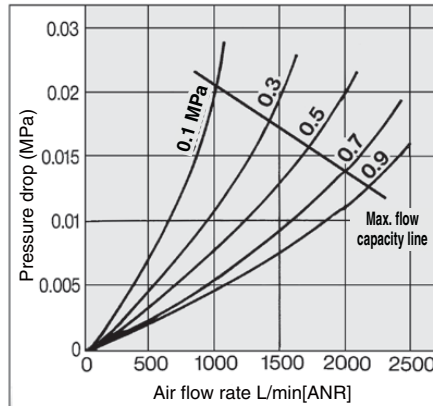

**10-AMF850**

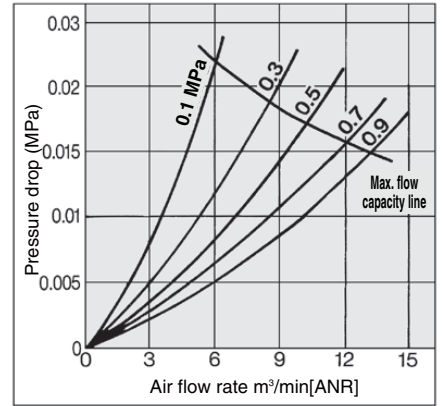

**10-AMF250C**

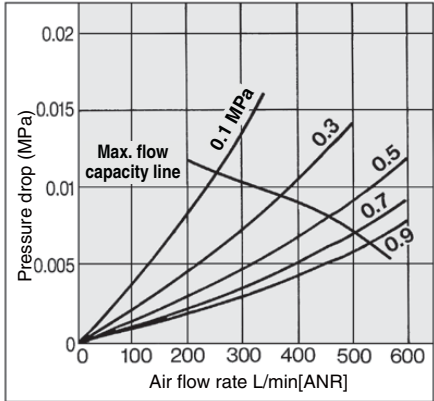

**10-AMF550C**

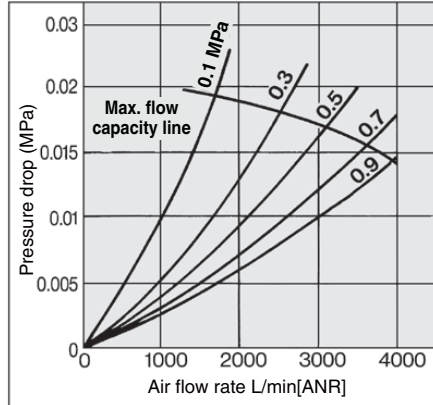

**10-AMF350C**

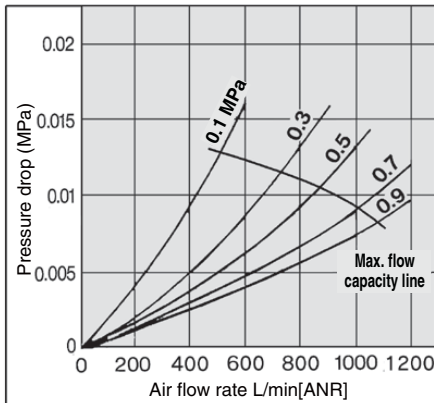

**10-AMF650**

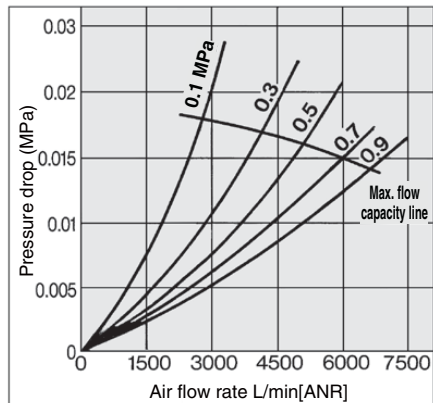

**Construction**

**10-AMF150C to 550C**

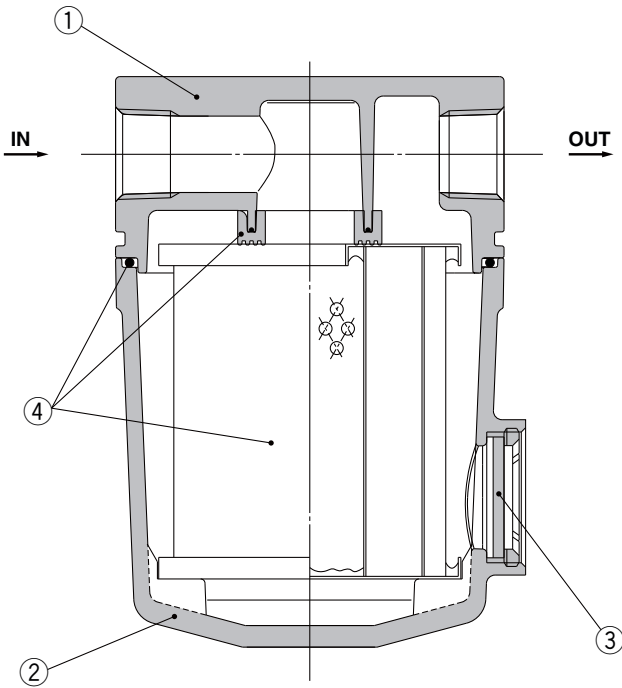

**10-AMF650, 10-AMF850**

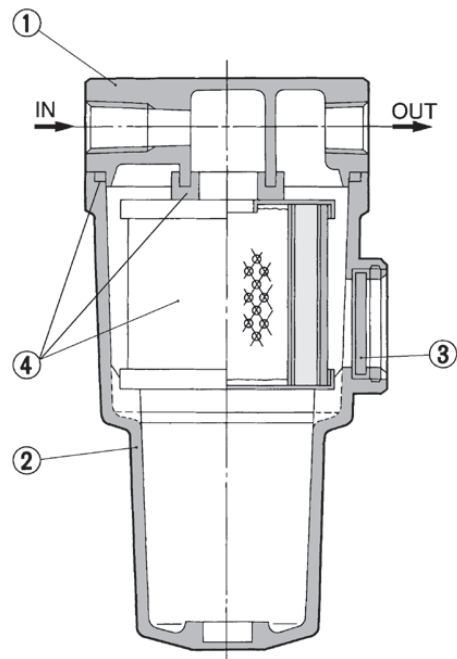

**Component Parts**

No.	Description	Material	Note
1	<b>Body</b>	Aluminum die-casted	Inner/outer surface coating
2	<b>Housing</b>	Aluminum die-casted*	surface coating
3	<b>Sight glass</b>	Tempered glass	—

\* The 10-AMF850 is aluminum casted.

**Replacement Parts**

No.	Description	Material	Applicable model	Model						
				10-AMF150C	10-AMF250C	10-AMF350C	10-AMF450C	10-AMF550C	10-AMF650	10-AMF850
4	<b>Element assembly</b>	Glass fiber, others	Except option F	10-AMF-EL150	10-AMF-EL250	10-AMF-EL350	10-AMF-EL450	10-AMF-EL550	10-AMF-EL650	10-AMF-EL850
			For option F	10-AMF-EL150-F	10-AMF-EL250-F	10-AMF-EL350-F	10-AMF-EL450-F	10-AMF-EL550-F	—	—

- Element assembly: With gasket (1 pc.) and O-ring (1 pc.)
- Refer to How to Order Bowl Assembly on page 1002.

Note) Sight glass is indicated in the figure for easy understanding of component parts. However, it differs from the actual construction. Refer to Dimensions on pages 999 to 1000 for details.

Directional Control Valves

Air Cylinders

Rotary Actuators

Air Grippers

Air Preparation Equipment

Modular F. R.

Pressure Control Equipment

Fittings & Tubing

Flow Control Equipment

Pressure Switches/Pressure Sensors



**Dimensions**

**10-AMF150 to 350C**

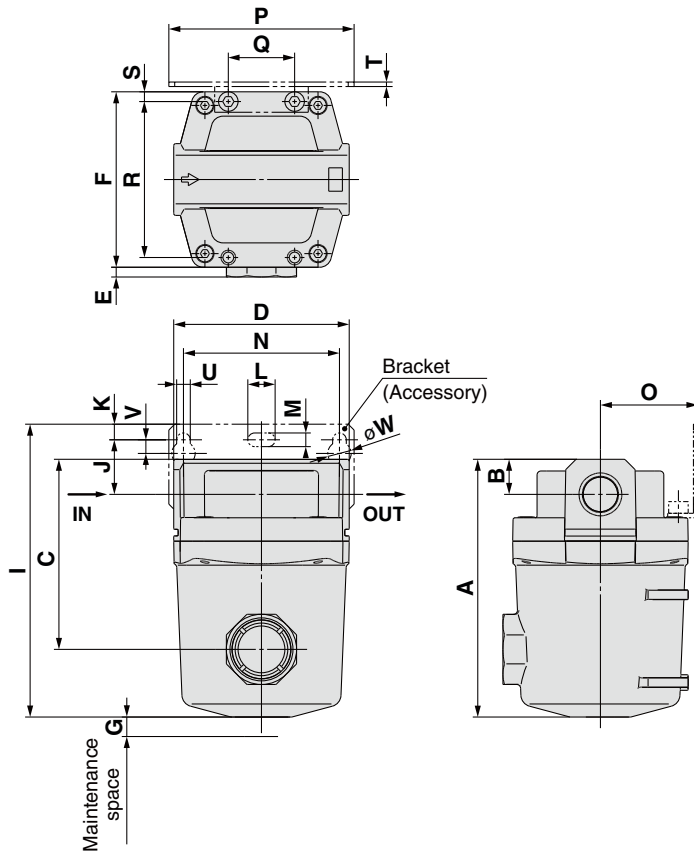

Model	Port size	A	B	C	D	E	F	G	[mm]
<b>10-AMF150C</b>	1/8, 1/4	83	10	54	63	7.5	63	10	
<b>10-AMF250C</b>	1/4, 3/8	103	14	73	76	5	76	10	
<b>10-AMF350C</b>	3/8, 1/2	132	18	98	90	5	90	10	

Model	Bracket related dimensions							
	I	N	J	K	U	V	L	M
<b>10-AMF150C</b>	99	56	20	5	6	6	12	6
<b>10-AMF250C</b>	121	66	24	8	6	6	12	6
<b>10-AMF350C</b>	150	80	28	8	7	7	14	7

Model	Bracket related dimensions						
	W	O	P	Q	R	S	T
<b>10-AMF150C</b>	10	35	70	26	54	4.5	1.6
<b>10-AMF250C</b>	10	40	80	28	66	5	2
<b>10-AMF350C</b>	12	50	95	34	80	5	2.3

**10-AMF450C/550C**

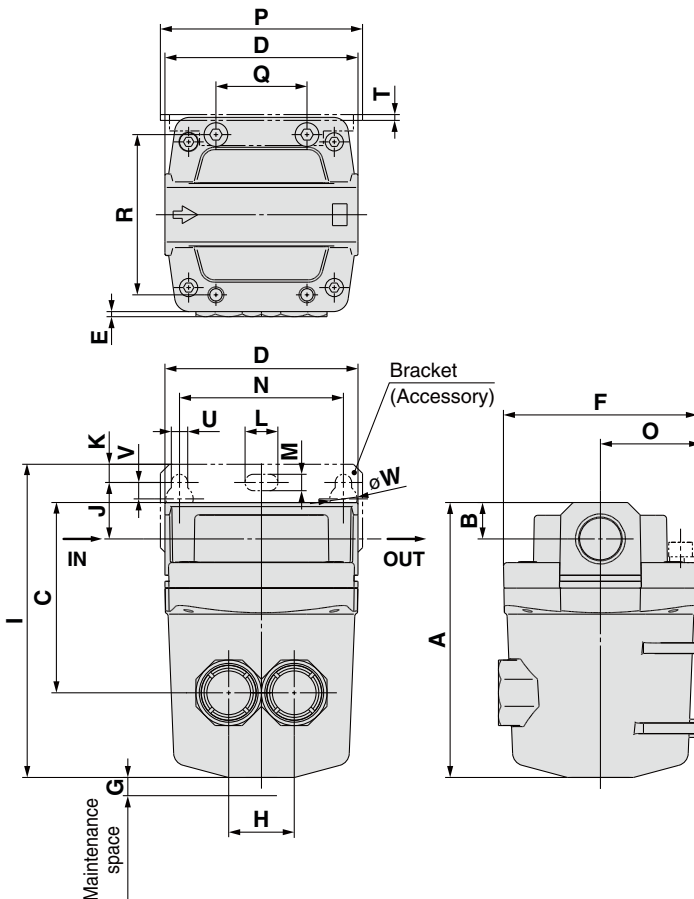

Model	Port size	A	B	C	D	E	F	G	H	[mm]
<b>10-AMF450C</b>	1/2, 3/4	151	20	105	106	3	106	10	36	
<b>10-AMF550C</b>	3/4, 1	187	24	130	122	3	122	15	44	

Model	Bracket related dimensions							
	I	N	J	K	U	V	L	M
<b>10-AMF450C</b>	172	90	31	10	9	9	18	9
<b>10-AMF550C</b>	206	100	33	10	9	9	18	9

Model	Bracket related dimensions					
	W	O	P	Q	R	T
<b>10-AMF450C</b>	15	55	111	50	88	3.2
<b>10-AMF550C</b>	15	65	126	60	102	3.2

**Dimensions**

**10-AMF650/850**

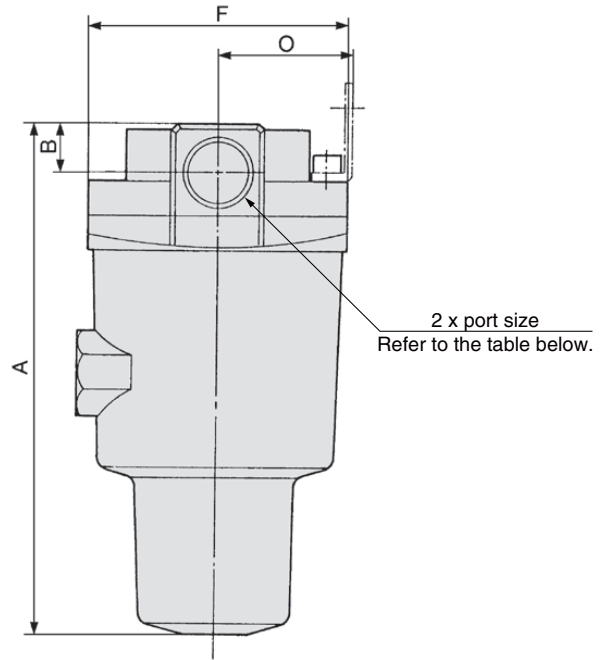
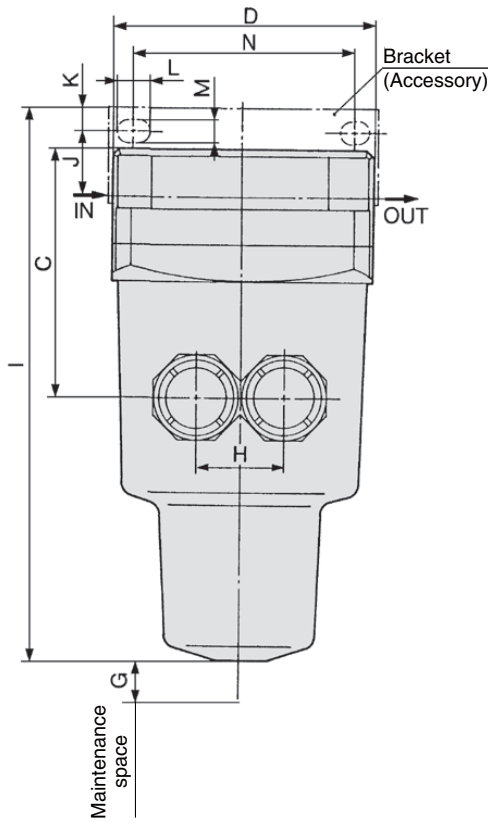
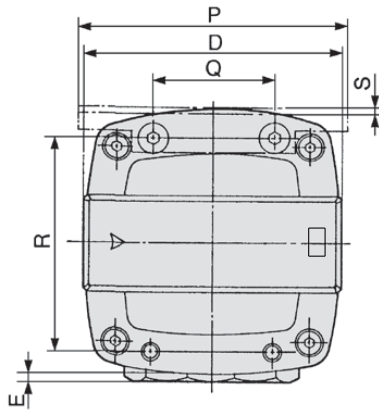

Model	Port size	A	B	C	D	E	F	G	H	Bracket related dimensions										
										I	J	K	L	M	N	O	P	Q	R	S
<b>10-AMF650</b>	1, 1 1/2	291	32	167	160	—	160	10	66	314	40	15	20	11	150	85	180	76	136	4.5
<b>10-AMF850</b>	1 1/2, 2	403	42	235	220	—	220	10	96	406	30	15	24	13	180	120	220	110	184	6

[mm]

Directional Control Valves

Air Cylinders

Rotary Actuators

Air Grippers

Air Preparation Equipment

Modular F. R.

Pressure Control Equipment

Fittings & Tubing

Flow Control Equipment

Pressure Switches/ Pressure Sensors

# Series 10-AM□/10-AFF□

# Spacer for Modular Connection

Select a spacer from those listed below when combining modular type 10-AFF2C to 22C, 10-AM□150C to 550C. The spacer must be ordered separately.  
 (Note: Spacer with bracket (10-Y200T to Y600T) cannot be used.)



## ⚠ Caution

- Modular connection
- Mount the attached bracket on one side when connecting 2 sets.
- Mount the attached brackets on both sides when connecting 3 sets or more.
- As a guideline for the number of brackets, one bracket should be mounted for every 2 products.

## Combination examples of modular applicable products

### Arrangement example

- 10-AMH250C-□□B — 1 pc.
- 10-AME250C — 1 pc.
- 10-Y300-A — 1 pc.

### Arrangement example

- 10-AMH250C-□□B — 1 pc.
- 10-AME250C — 1 pc.
- 10-AMF250C-□□B — 1 pc.
- 10-Y300-A — 2 pcs.

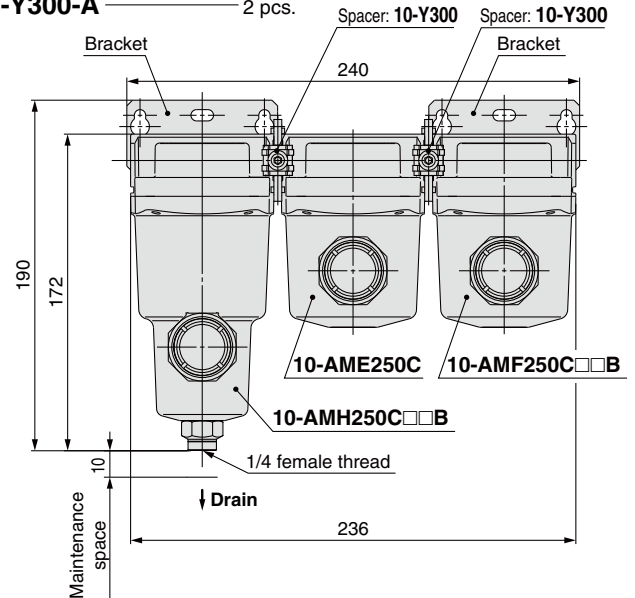
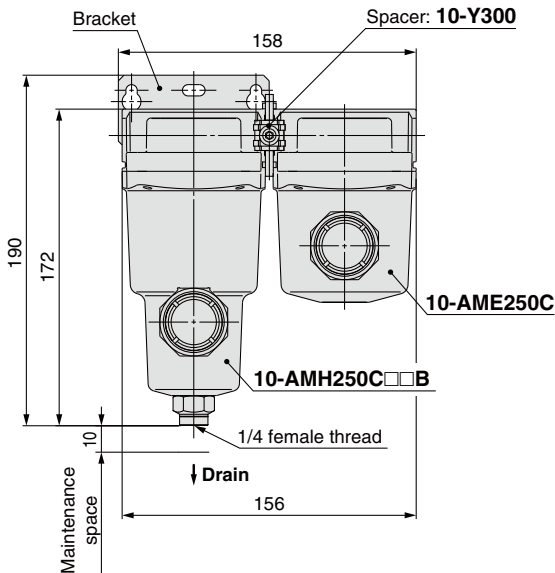

## Spacer

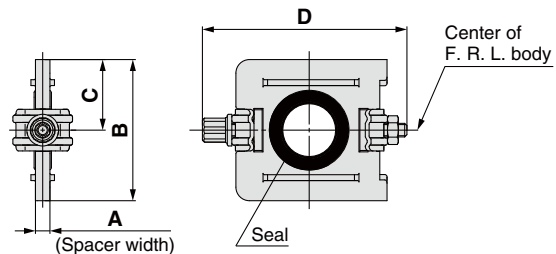

Model	A	B	C	D	Model
10-Y200-A	3.2	31.2	15.6	44.9	10-AFF2C, 10-AM□150C
10-Y300-A	4.2	43.4	21.7	57.9	10-AFF4C, 10-AM□250C
10-Y400-A	5.2	53	26.5	68.5	10-AFF8C, 10-AM□350C
10-Y500-A	5.2	57	28.5	75.6	10-AFF11C, 10-AM□450C
10-Y600-A	6.2	67.6	33.8	92.5	10-AFF22C, 10-AM□550C

## Replacement Parts

Description	Material	Part no.				
		10-Y200-A	10-Y300-A	10-Y400-A	10-Y500-A	10-Y600-A
Seal	HNBR	Y220P-050S	Y320P-050S	Y420P-050S	Y520P-050S	Y620P-050S

# 10-AFF-CA□/10-AM□-CA□

## Bowl Assembly

### Bowl Assembly

Bowl assembly for the AFF and AM □ series can be replaced without removing the main body from piping if the bowl has been damaged.

### How to Order Bowl Assembly

#### ■ 10-AFF2C to 22C, 10-AM, 10-AMD, 10-AMH

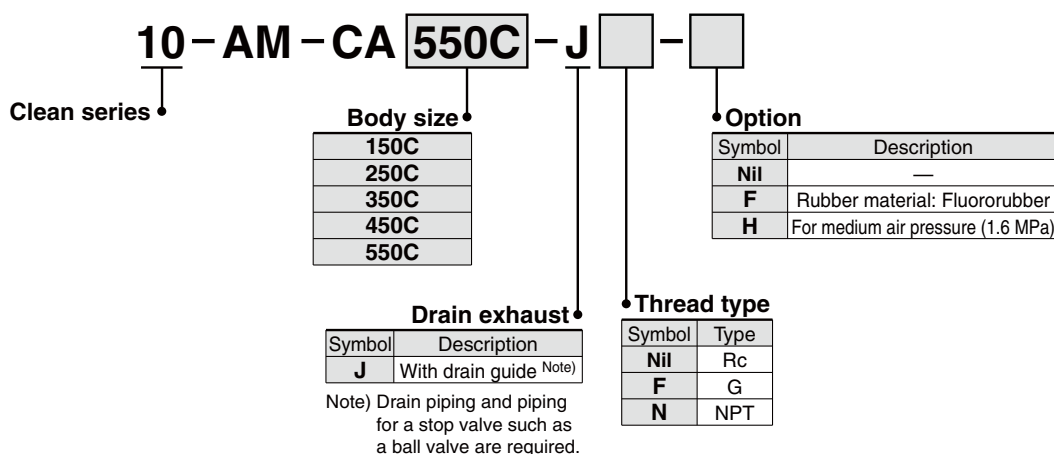

#### Applicable Model

Bowl assembly model	Applicable model
10-AM-CA150C-J	10-AFF2C, 10-AM150C, 10-AMD150C, 10-AMH150C
10-AM-CA250C-J	10-AFF4C, 10-AM250C, 10-AMD250C, 10-AMH250C
10-AM-CA350C-J	10-AFF8C, 10-AM350C, 10-AMD350C, 10-AMH350C
10-AM-CA450C-J	10-AFF11C, 10-AM450C, 10-AMD450C, 10-AMH450C
10-AM-CA550C-J	10-AFF22C, 10-AM550C, 10-AMD550C, 10-AMH550C

#### ■ 10-AFF37B/75B

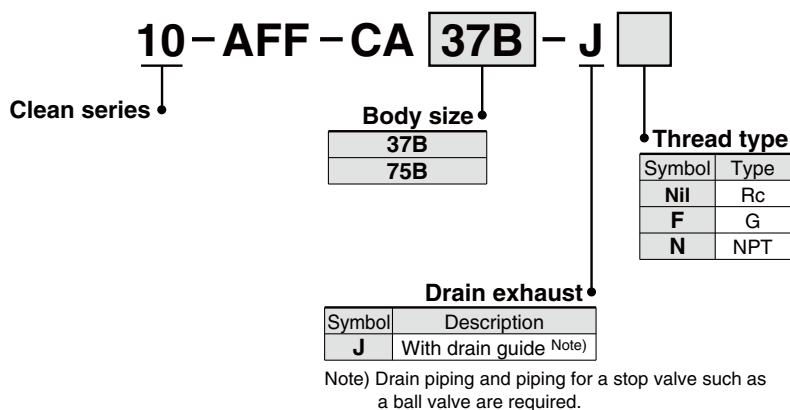

Directional Control Valves

Air Cylinders

Rotary Actuators

Air Grippers

Air Preparation Equipment

Modular F. R.

Pressure Control Equipment

Fittings & Tubing

Flow Control Equipment

Pressure Switches/ Pressure Sensors

## How to Order Bowl Assembly

### ■ 10-AM, 10-AMD, 10-AMH

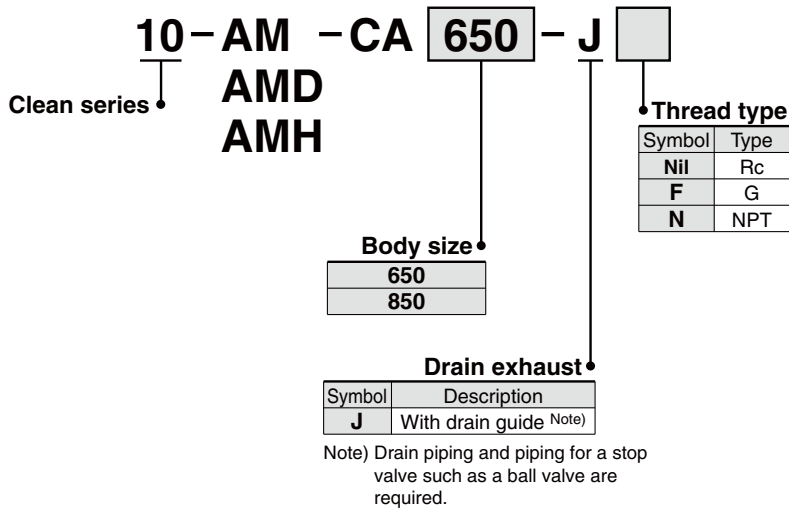

### ■ 10-AME, 10-AMF150C to 550C

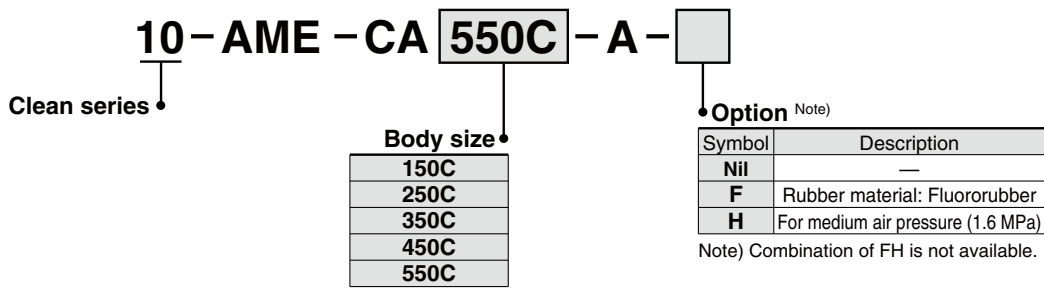

#### Applicable Model

Bowl assembly model	Applicable model
10-AME-CA150C-A	10-AME150C, 10-AMF150C
10-AME-CA250C-A	10-AME250C, 10-AMF250C
10-AME-CA350C-A	10-AME350C, 10-AMF350C
10-AME-CA450C-A	10-AME450C, 10-AMF450C
10-AME-CA550C-A	10-AME550C, 10-AMF550C

### ■ 10-AME, 10-AMF650, 850

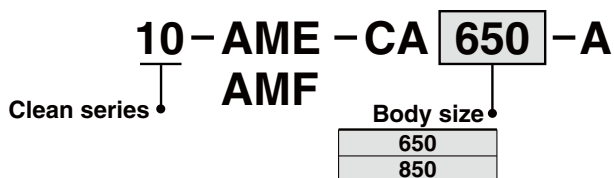

**Dimensions: Series 10-AFF, 10-AM, 10-AMD, 10-AMH**

**Size: 10-AFF2C to 22C, 10-AFF37B, 10-AM□150C to 550C, 10-AM□650**

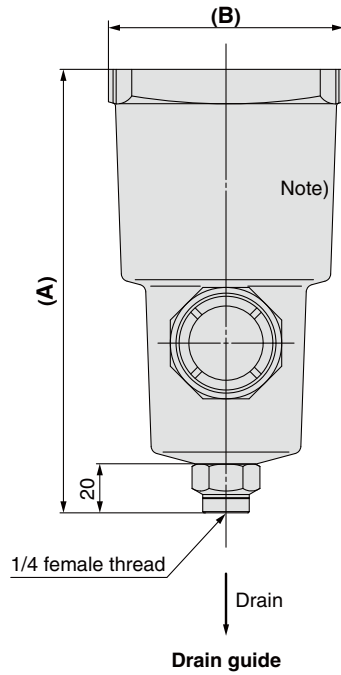

Series AFF	Series AM, AMD, AMH	(mm)	
Size	Size	A	B
<b>2C</b>	<b>150C</b>	134	63
<b>4C</b>	<b>250C</b>	139	76
<b>8C</b>	<b>350C</b>	162	90
<b>11C</b>	<b>450C</b>	178	106
<b>22C</b>	<b>550C</b>	202	122
<b>37B</b>	<b>650</b>	245	160

Note) Model no. labels are not affixed to the AM-CA150C to 550C.

**Size: 10-AFF75B, 10-AM□850**

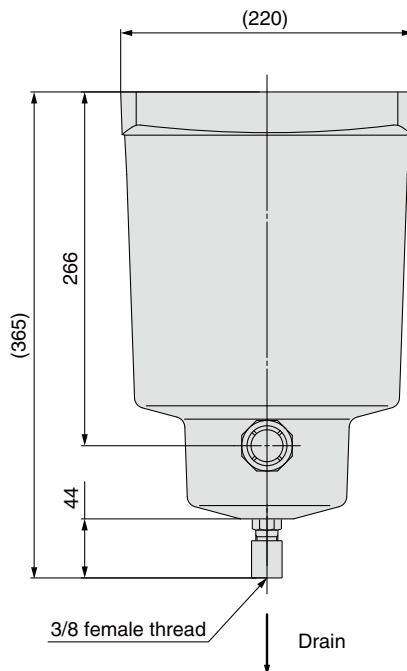

**Bowl Assembly 10-AFF-CA□/10-AM□-CA□**

**Dimensions: Series 10-AME, 10-AMF**

**■ 10-AME150C to 550C, 10-AMF150C to 550C**

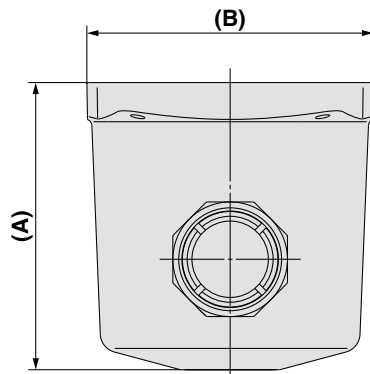

(mm)

Series 10-AME, 10-AMF Size	A	B
<b>150</b>	60	63
<b>250</b>	70	76
<b>350</b>	90	90
<b>450</b>	104	106
<b>550</b>	130	122

**■ 10-AME650/850, 10-AMF650/850**

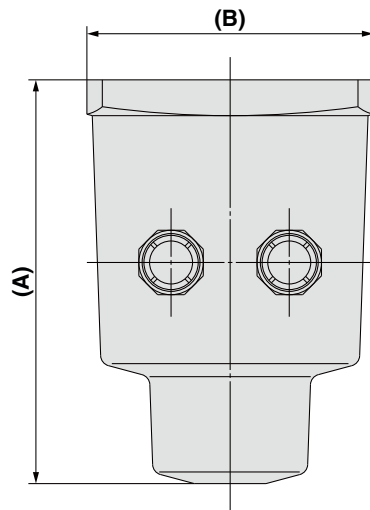

(mm)

Series 10-AME, 10-AMF Size	A	B
<b>650</b>	225	160
<b>850</b>	319	120



# Series 10-AM□/10-AFF Specific Product Precautions 1

Be sure to read this before handling.

Refer to page 1382 for Safety Instructions and pages 1064 to 1066 for Air Preparation Equipment Precautions.

## Design

### ⚠ Caution

1. Design the layout so that this product should be installed in an area that is less susceptible to pulsations.

The element could be damaged if a difference between the inlet pressure and the outlet pressure exceeds 0.1 MPa.

2. Be careful of dust generation by the pneumatic equipment mounted on the outlet side.

When installing pneumatic equipment on the outlet side of the 10-AFF series, 10-AM□ series, dust particles may come off from outlet equipment, which will lower the cleanliness of compressed air. Consider this impact upon the cleanliness of compressed air when installing pneumatic equipment on the outlet side.

3. Use the 10-AFF and 10-AM as a pre-filter for the 10-AME and 10-AMF.

(Do not use outlet air of the 10-AFF and 10-AM in a clean room.)

4. Provide a design that prevents back pressure and back flow.

Back pressure or back flow may damage an element.

### ⚠ Warning

1. Hold the female thread side and tighten to the recommended torque when screwing in the piping material.

Insufficient tightening torque may cause loosening or defective sealing. Over-tightening torque may damage the thread etc. If it is tightened without holding the female thread side, excessive force will be directly applied to the piping bracket resulting in a product failure.

#### Recommended Torque

Unit: N·m

Connection thread	1/8	1/4	3/8	1/2	3/4	1	1 1/2	2
Torque	7 to 9	12 to 14	22 to 24	28 to 30	28 to 30	36 to 38	48 to 50	48 to 50

\* After tightening manually, tighten additionally by about 1/6 turn with a tightening tool.

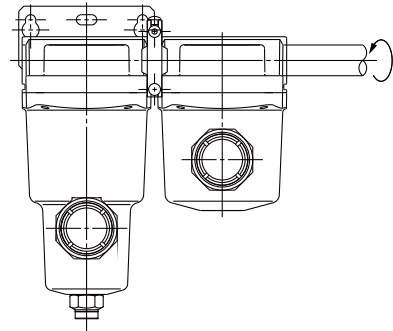

2. Do not apply torsional moment or bending moment (except the product's own weight) to the bracket. It may damage the bracket. Support external piping separately.

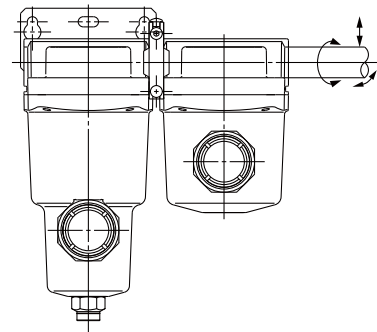

3. Inflexible piping such as steel piping tends to be affected by spread of excessive moment load or vibration from the piping side. Lay flexible tubing between the steel pipe and the product to prevent such effects.

Directional Control Valves

Air Cylinders

Rotary Actuators

Air Grippers

Air Preparation Equipment

Modular F. R.

Pressure Control Equipment

Fittings & Tubing

Flow Control Equipment

Pressure Switches/ Pressure Sensors





# Series 10-AM□/10-AFF

## Specific Product Precautions 2

Be sure to read this before handling.

Refer to page 1382 for Safety Instructions and pages 1064 to 1066 for Air Preparation Equipment Precautions.

### Selection

#### ⚠ Caution

##### 1. About the system composition of purifying compressed air

Compressed air generally contains particulate contaminants as listed below, though there are some variations due to the compressor type and specifications. Determine the system configuration according to the desired cleanliness of compressed air and application, while referring to the Air Preparation Equipment Selection Guide for the 10-AM□ series (Best Pneumatics No.⑤ P. 2, 3).

##### [Particulate contaminants in compressed air]

- Water (drainage)
- Dust sucked from ambient air
- Degenerated oil from compressor
- Solid foreign matter such as rust inside piping and oil

##### 2. Select according to the maximum flow capacity.

When compressed air is used for air blow, etc., find the maximum air consumption before selecting the size of the 10-AM□ series. (If compressed air exceeding the maximum flow capacity is supplied, it can result in decline of the cleanliness of compressed air or discharge of oil mist to outlet side.)

### Mounting

#### ⚠ Caution

##### 1. About the mounting orientation of the products

Make sure to install this product on horizontal piping. If it is installed diagonally, laterally, or upside down, the drain separated by the element will splash to the outlet side.

### Piping

#### ⚠ Caution

##### 1. Connect it with IN and OUT ports in proper location. It does not work with the connection reversed.

In the case of the 10-AFF2C to 22C, 37B, 75B, 10-AM□150C to 550C, 650, 850

Verify the direction of the flow of the compressed air and the “⇨” mark that indicates the inlet of the product before connecting. It cannot be used if connected in the opposite direction.

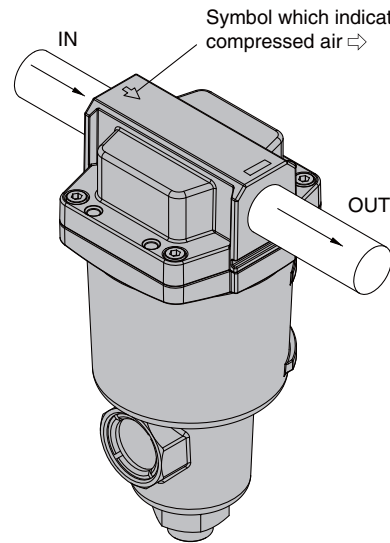

##### 2. Use an air blower to flush the piping before connecting the piping.

Use an air blower to thoroughly flush the piping, or wash the piping to remove any cutting chips, cutting oil, or debris from inside the piping before connecting them.

##### 3. Winding of sealant tape

When screwing in the pipes or fittings, make sure to prevent cutting chips or the sealant material on the threaded portion of the pipe from entering the piping. If sealant tape is to be used, leave about 1.5 to 2 ridges of threads uncovered.

##### 4. Modular connection

Mount the attached bracket on one side when connecting 2 sets. Mount the attached brackets on both sides when connecting 3 sets or more. As a guideline for the number of brackets, one bracket should be mounted for every 2 products.



# Series 10-AM□/10-AFF

## Specific Product Precautions 3

Be sure to read this before handling.

Refer to page 1382 for Safety Instructions and pages 1064 to 1066 for Air Preparation Equipment Precautions.

### Air Supply

#### ⚠ Caution

**1. This product is not applicable to gases other than compressed air.**

This product is not applicable to gases other than compressed air (example: oxygen, hydrogen, flammable gas, mixed gas).

**2. Do not use compressed air that contains chemicals, organic solvents, salt, or corrosive gases.**

Do not use compressed gas containing chemicals, organic solvents, salt or corrosive gas. This can cause rust, damage to rubber and resin parts, or malfunction.

**3. Operate within the specified operating pressure range.**

Damage, failure, or malfunction may occur if this product is operated above the maximum operating pressure.

If this product is used below the minimum operating pressure, increase in the air-flow resistance due to clogging will have such influence that the desired flow rate cannot be obtained.

If this product is used under a low pressure such as for a blower, conduct sufficient tests by users to confirm the specifications and performances.

### Operating Environment

#### ⚠ Caution

**1. Do not use in the following environments, as this can cause failure.**

- 1) In locations having corrosive gases, organic solvents, and chemical solutions, or in locations where these elements are likely to adhere to the equipment.
- 2) In locations where salt water, water, or water vapor could come in contact with the equipment.
- 3) In locations that is exposed to shocks and vibrations.

**2. Be careful about the contamination of the workpieces due to entrainment of the ambient air.**

If compressed air is used for air blow, compressed air blowing out from the blow nozzle may entrain foreign matter (solid particles and liquid particles) floating in the ambient air, blowing it against the workpieces and causing adhesion. Therefore, sufficient precautions must be taken about the ambient environment.

### Maintenance

#### ⚠ Caution

**1. Replace the element immediately when the time for its replacement has arrived.**

To replace the element, replace the O-ring and the gasket, too. For the replacement procedure, refer to the operation manual.

**<Element replacement>**

a. In the case of the 10-AFF2C to 22C, 37B, 75B, 10-AM□150C to 550C, 650, 850

The replacement interval for the element is when the pressure drop reaches 0.1 MPa or after two years of operation, whichever comes first. [A pressure drop can be verified with the element service indicator (-T)]

b. In the case of the 10-AME

Regardless of the time for its replacement indicated in "a" above, replace the element when a red color spot occurred on the surface.

c. In the case of the 10-AMF

Regardless of the time for its replacement indicated in "a" or "b", replace the element when you smell oil on the outlet side.

**2. Be sure to exhaust the drain accumulated in the filter container.**

Failure to discharge the drain will allow the accumulated drain to flow over to the outlet side.

Drain guide or ball valve, discharge the drain before the drainage level reaches the center of the sight glass. If the drain is not discharged properly, it will flow over to the outlet side.

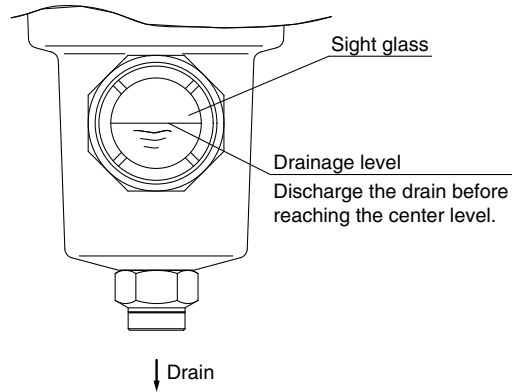

Directional Control Valves

Air Cylinders

Rotary Actuators

Air Grippers

Air Preparation Equipment

Modular F. R.

Pressure Control Equipment

Fittings & Tubing

Flow Control Equipment

Pressure Switches/Pressure Sensors