

Pneumatic-Pneumatic Positioner (Lever type/Rotary type) IP5000/5100 Series

● JIS F8007 IP55

How to Order



IP5 000 - 0 1 0 - - -

Type	
000	Lever type
100	Rotary type

Input pressure	
0	0.02 to 0.1 MPa (Standard)
1	0.02 to 0.06 MPa 0.06 to 0.1 MPa

Pressure gauge (SUP, OUT1)	
0	None
1	0.2 MPa
2	0.3 MPa
3	1 MPa

Indication of opening ^{Note)}	
0	Not provided
1	Indicated

Note) IP5000 is available only with option "0" (no indication).

Ambient temperature	
Nil	-20 to 80°C (Standard)
T	-5 to 100°C (High temperature)
L	-30 to 60°C (Low temperature)

Pressure gauge/Air port	
Nil	Rc (Standard)
N	NPT
F	G

● Accessories ^{Note 1)}

Accessories	Description	Notes
Nil	None (Standard)	With standard lever (10 to 85 mm stroke) for IP5000
A	ø0.7 Output restriction with pilot valve	Common to IP5000 and IP5100 small capacity actuators
B	ø1.0 Output restriction with pilot valve	
C	Fork lever-type fitting M	Only for IP5100
D	Fork lever-type fitting S	
E	For stroke 35 to 100 mm with lever unit	Only for IP5000 ^{Note 2)}
F	For stroke 50 to 140 mm with lever unit	

Note 1) If two or more accessories are required, the part numbers should be given in alphabetical order.
Ex.) IP5000-010-AD

Note 2) For "E" and "F", standard lever is not provided.

Precautions

- Avoid impact to positioner while transporting and handling.
- Operate within specified temperature range to prevent deterioration of seals.
- Attach a body cover to the positioner when it is in use or left in the field in order to avoid rain water.
- Take measures to avoid dew condensation if the positioner is exposed to high temperature and humidity during transportation or storage or when it is left on the site.
- The zero point is subject to the mounting position. Adjust zero point after installation on the site.
- As the positioner contains extra-fine orifices such as restrictor and nozzle, if drain or dust is present in the supply pressure line, malfunction (*1) may result. In addition to an air filter (SMC Series AF), it is recommended to use a mist separator (SMC Series AM, AFM) and a micro mist separator (SMC Series AMD, AFD). Also, refer to "SMC Air Preparation System" for air quality.
- Never use a lubricant, as this can cause a malfunction (*1).

*1 If the restrictor is clogged, output from the OUT1 port of the positioner may occur continuously or hunching and overshoot may occur.

Specifications ^{Note 1)}

Item	Type	IP5000		IP5100	
		Lever type lever feedback		Rotary type cam feedback	
		Single action	Double action	Single action	Double action
Supply pressure		0.14 to 0.7 MPa			
Input pressure		0.02 to 0.1 MPa			
Standard stroke		10 to 85 mm		60° to 100° ^{Note 3)}	
Sensitivity ^{Note 4)}		Within 0.1% F.S.		Within 0.5% F.S.	
Linearity ^{Note 2, 4)}		Within ±1% F.S.		Within ±2% F.S.	
Hysteresis ^{Note 2, 4)}		Within 0.75% F.S.		Within 1% F.S.	
Repeatability ^{Note 4)}		Within ±0.5% F.S.			
Air consumption ^{Note 5)}		5 L/min (ANR) or less (SUP = 0.14 MPa) ^{Note)}		11 L/min (ANR) or less (SUP = 0.4 MPa) ^{Note)}	
Output flow rate ^{Note 5)}		80 L/min (ANR) or more (SUP = 0.14 MPa) ^{Note)}		200 L/min (ANR) or more (SUP = 0.4 MPa) ^{Note)}	
Ambient and fluid temperature		-20°C to 80°C (Standard)			
Coefficient of temperature		Within 0.1% F.S./°C			
Air connection port ^{Note 6)}		Rc1/4 (Standard)			
Main component parts		Aluminum die-cast, Stainless steel, Brass, Nitrile rubber			
Weight		Approx. 1.4 kg		Approx. 1.2 kg	
Dimensions		118 x 102 x 86 (Body)		118 x 92 x 77.5 (Body)	

Note 1) Specification values are given at normal temperature (20°C).

Note 2) 1/2 Split range (Standard) For operation with 1/2 split range, the linearity and hysteresis should be 1% F.S. higher than the above specifications.

Note 3) Stroke adjustment: 0 to 60°, 0 to 100°

Note 4) Characteristics relating to accuracy differ depending on combination with other constituent loop equipment, such as positioners and actuators.

Note 5) Air consumption is due to exhaust from nozzle. And (ANR) indicates JIS B0120 standard air.

Note 6) Thread type can be specified by model selection.

Replacement Parts

Part no.	Description	Note
P378010-10	Pilot valve unit	For IP5000
P378020-11	Pilot valve unit	For IP5100
P368010-24	Fork lever assembly M	For IP5100 (Accessory: C)
P368010-25	Fork lever assembly S	For IP5100 (Accessory: D)
P378010-11	Feedback lever	For IP5000/10 to 85 mm (Accessory: Nil)
P378010-12	Feedback lever	For IP5000/35 to 100 mm (Accessory: E)
P378010-13	Feedback lever	For IP5000/50 to 140 mm (Accessory: F)

IP5000/5100 Series

Principle of Operation

IP5000 type

When the input pressure applied to the SIG port of the positioner increases, bellows ① press balance lever ② to the left. As this movement moves flapper ④ to the left through connecting spring ③, the gap between nozzle ⑤ and flapper ④ widens, and the nozzle back pressure of pilot valve ⑥ drops. As a result, the pressure balance in the constant pressure chamber is broken, and exhaust valve ⑬ presses inlet valve B ⑭ to the right, thus opening inlet port B. Then, output pressure OUT1 rises, and driven diaphragm ⑦ moves downward.

The movement of diaphragm valve ⑦ deflects feedback arm ⑪ to the right through feedback lever ⑧, transmission lever ⑨, and roller ⑩. Such deflection increases the tension of feedback spring ⑫ and acts on balance lever ②.

Since driven diaphragm ⑦ moves until the tensile force of feedback spring ⑫ and the force generated by bellows ① balance, it is always set in the position proportional to the input pressure. When the signal air pressure decreases, the operation is reversed.

IP5000 principle of operation

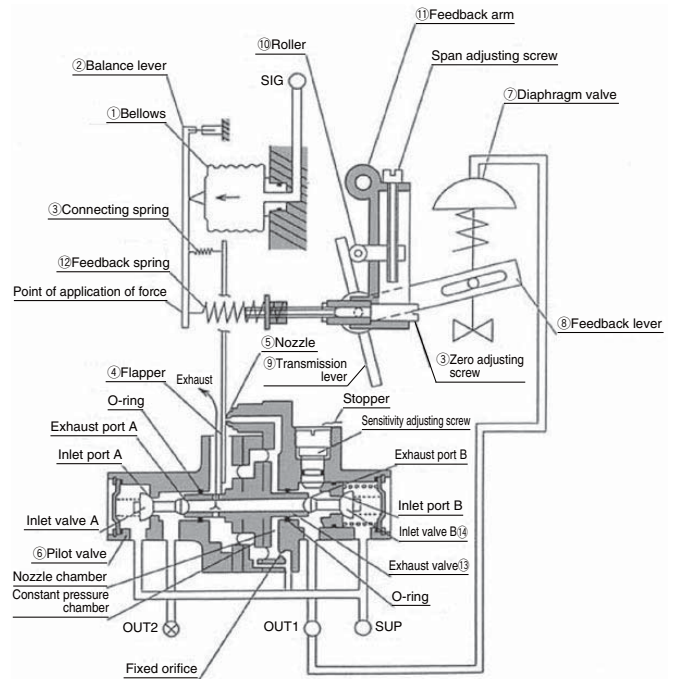

IP5100 type

When the input pressure applied to the SIG port of the positioner increases, bellows ① press balance lever ② to the left. As this movement moves flapper ④ to the left through connecting spring ③, the gap between nozzle ⑤ and flapper ④ widens, and the nozzle back pressure of pilot valve ⑥ drops. As a result, the pressure balance in the constant pressure chamber is broken, and exhaust valve ⑭ presses inlet valve B ⑮ to the right. Then, inlet port B opens, and output pressure OUT1 increases.

In the meantime, the movement of exhaust valve ⑭ to the right opens exhaust port A, and output pressure OUT2 decreases. Therefore, pressure difference is generated between pressure chamber 1 and pressure chamber 2 of oscillating actuator ⑦, and actuator shaft ⑧ turns in the direction of the arrow. The movement of actuator shaft ⑧ deflects feedback arm ⑫ to the right through feedback shaft ⑨, cam ⑩, and bearing ⑪. Such deflection increases the tension of feedback spring ⑬ and acts on balance lever ②.

Since oscillating actuator ⑦ moves until the tensile force of feedback spring ⑬ and the force generated by bellows ① balance, it is always set in the position proportional to the input pressure. When the signal air pressure decreases, the operation is reversed.

IP5100 principle of operation

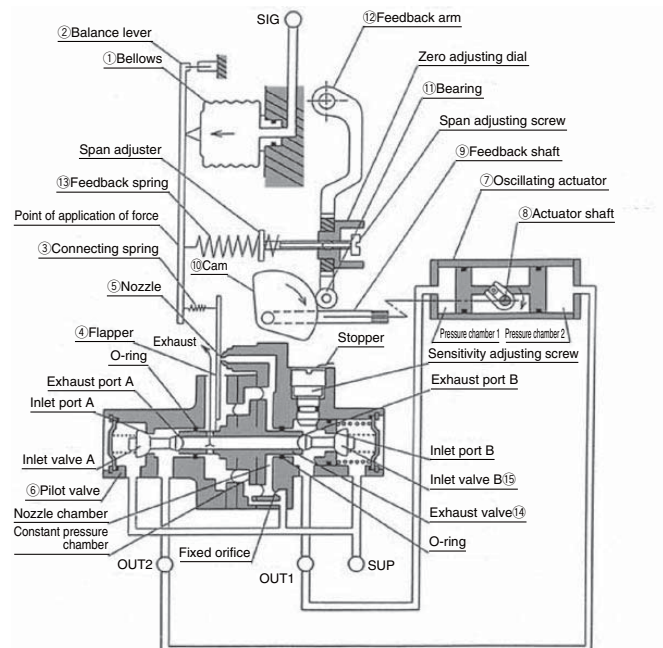

Dimensions

IP5000 type (Lever type lever feedback)

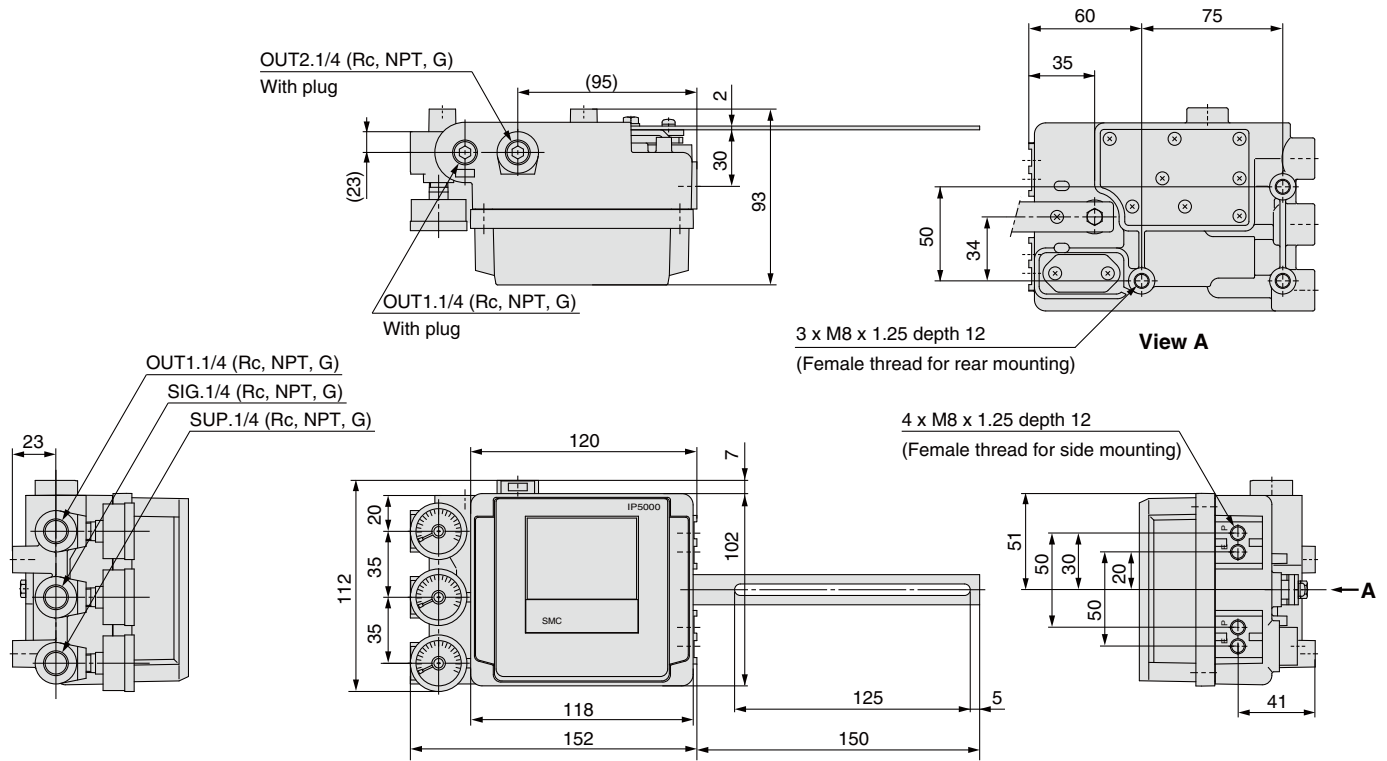

IP5100 type (Rotary type cam feedback)

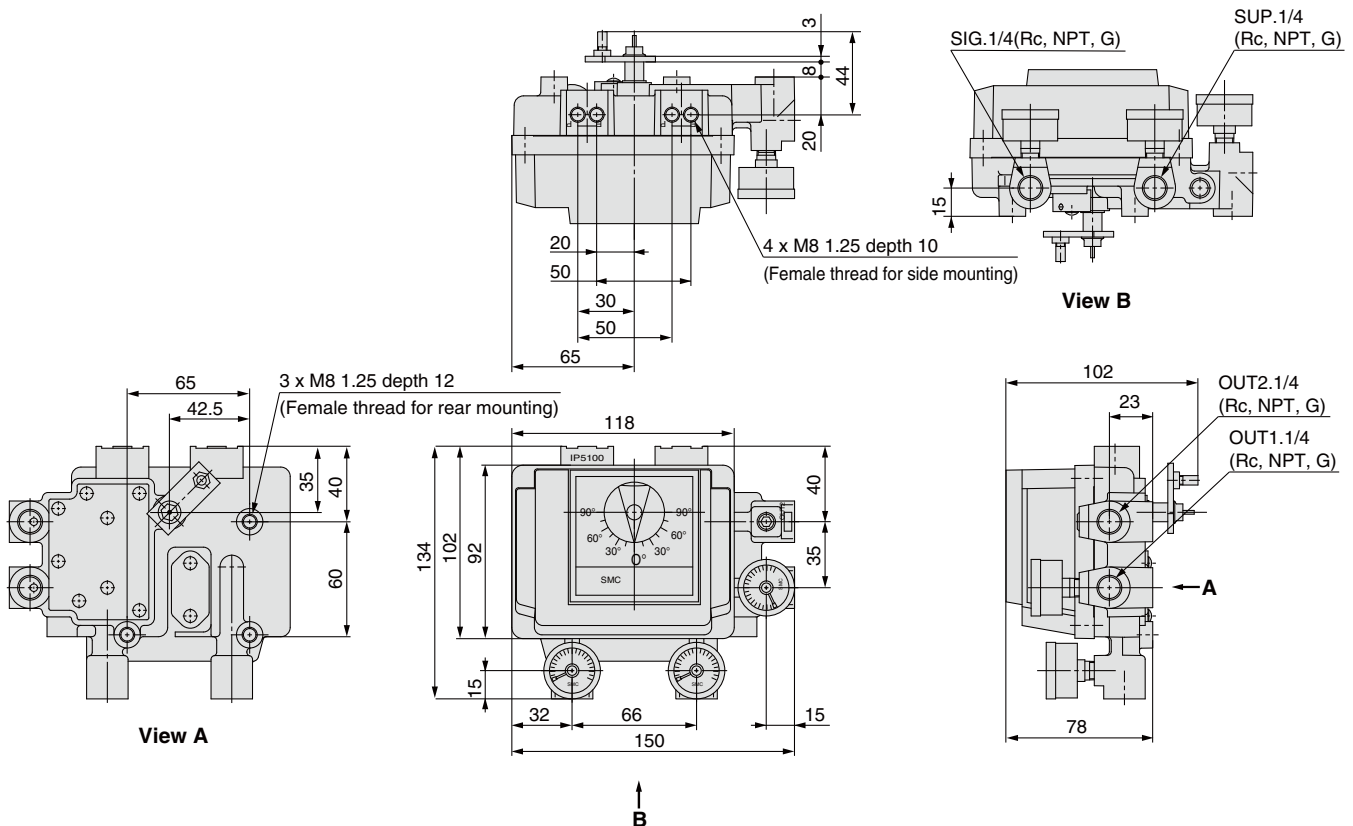

IP

IW

1301

AW

IL1

IL2

IT

CP

IS

VFN

IN-
T

B

