

Pilot Check Valve: Metal Body Type

■ The use of a metal body improves strength and environmental resistance.

■ Temporary intermediate stops are possible.*1

*1 Precise intermediate stops are not guaranteed.

Example of a drop prevention circuit

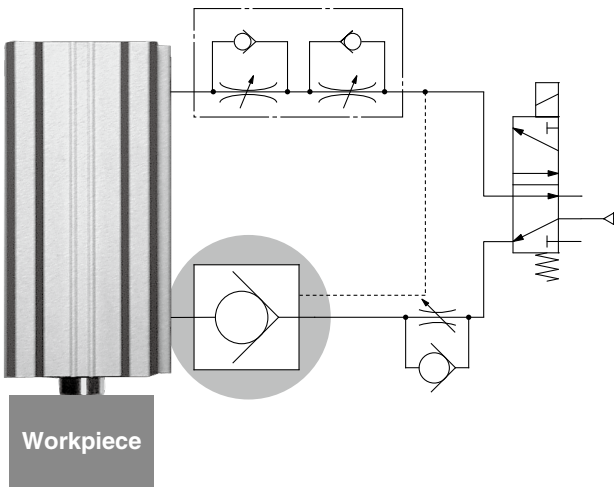

■ Three types capable of connecting to female threads and One-touch fittings are available.

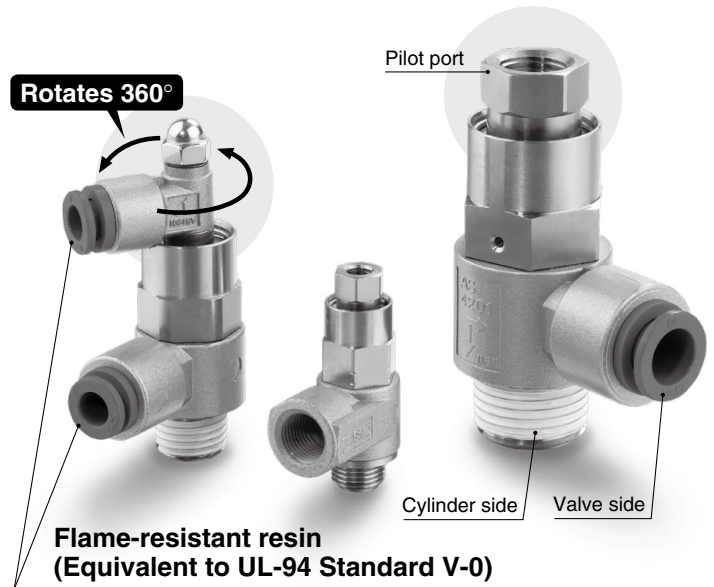

Model

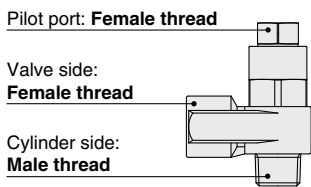

Model	Port size on the cylinder side		Pilot port		Port size on the valve side			
					Female thread (Rc, G)			
					1/8	1/4	3/8	1/2
AS2200-□01□-X785	R, G	1/8	M5	Rc, G	●	—	—	—
AS2200-□02□-X785		1/4			—	●	—	—
AS3200-□03□-X785		3/8	1/8		—	—	●	—
AS4200-□04□-X785		1/2	1/4		—	—	—	●

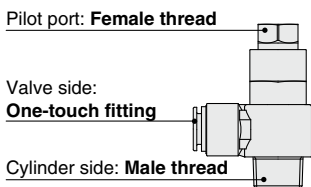

Model	Port size on the cylinder side		Pilot port		Port size on the valve side	
					One-touch fitting	
					ø10	ø12
AS4201-□04-F□□-X785	R, G	1/2	Rc, G	1/4	●	●

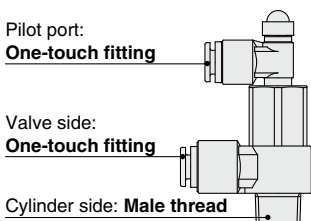

Model	Port size on the cylinder side		Pilot port		Port size on the valve side		
					One-touch fitting		
					ø6	ø8	ø10
AS2201-□01-F□□-X785	R, G	1/8	ø6	—	●	●	—
AS2201-□02-F□□-X785		1/4			●	●	●
AS3201-□03-F□□-X785		3/8			—	●	●

AS-X785



16-E672

AS-X785

Specifications

Symbol

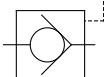

Fluid	Air
Proof pressure	1.5 MPa
Max. operating pressure	1 MPa
Min. operating pressure	0.1 MPa
Pilot check valve operating pressure	50% or more of the operating pressure (0.1 MPa or more)
Ambient and fluid temperatures	-5 to 60°C (No freezing)
Applicable tubing materials	Nylon, Soft nylon, Polyurethane

* Use caution at the max. operating pressure when using soft nylon or polyurethane tubing. (Refer to the [Web Catalog](#) for details.)

Flow Rate and Sonic Conductance

Model	AS2200-□01□-X785	AS2200-□02□-X785		AS3200-□03□-X785		AS4200-□04□-X785	
	AS2201-□01-F□□-X785	AS2201-□02-F□□-X785		AS3201-□03-F□□-X785		AS4201-□04-F□□-X785	
Port size on the valve side	ø6, ø8, 1/8	ø6, ø8	ø10, 1/4	ø8	ø10, 3/8	ø10	ø12, 1/2
Sonic conductance [dm ³ /(s·bar)]	0.8	1.3	1.4	3.1	3.2	5.1	5.8
Critical pressure ratio	0.25	0.25	0.25	0.25	0.25	0.25	0.25

How to Order

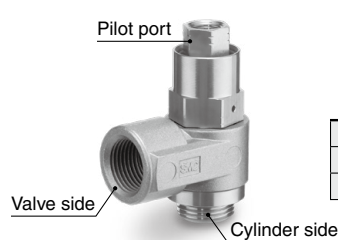

AS 2 200 - □ 01

Body size

2	1/8, 1/4
3	3/8
4	1/2

Thread type

Nil	R, Rc
G	G

Port size

	Cylinder side
01	1/8
02	1/4
03	3/8
04	1/2

S - X785

Seal method

Nil	Without sealant (for G)
S	With sealant (for R)

* R thread type: With sealant
G thread type: Without sealant

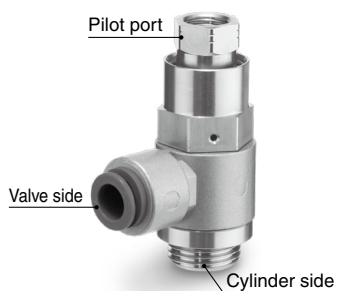

AS4201 - □ 04 - F 10 S - X785

Thread type

Nil	R, Rc
G	G

Port size

	Cylinder side
04	1/2

With One-touch fitting

Seal method

Nil	Without sealant (for G)
S	With sealant (for R)

* R thread type: With sealant
G thread type: Without sealant

Valve side applicable tubing O.D.*1

10	ø10
12	ø12

*1 For selecting applicable tubing O.D., refer to the cover page.

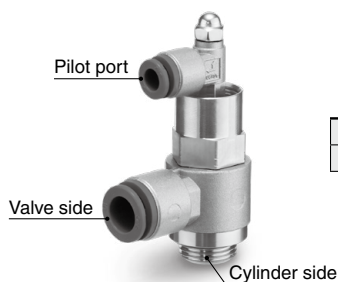

AS 2 201 - □ 01 - F 06 S - X785

Body size

2	1/8, 1/4
3	3/8

Thread type

Nil	R
G	G

Port size

	Cylinder side
01	1/8
02	1/4
03	3/8

With One-touch fittings

Seal method

Nil	Without sealant (for G)
S	With sealant (for R)

* R thread type: With sealant
G thread type: Without sealant

Valve side applicable tubing O.D.*1

06	ø6
08	ø8
10	ø10

*1 For selecting applicable tubing O.D., refer to the cover page.

Construction

Female thread (Pilot port)

With One-touch fittings (Pilot port)

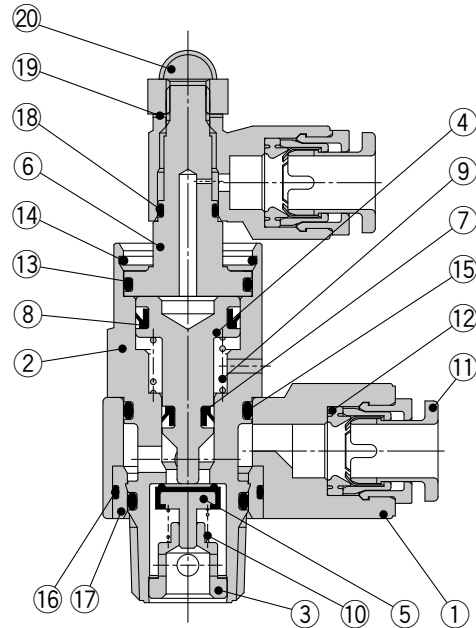
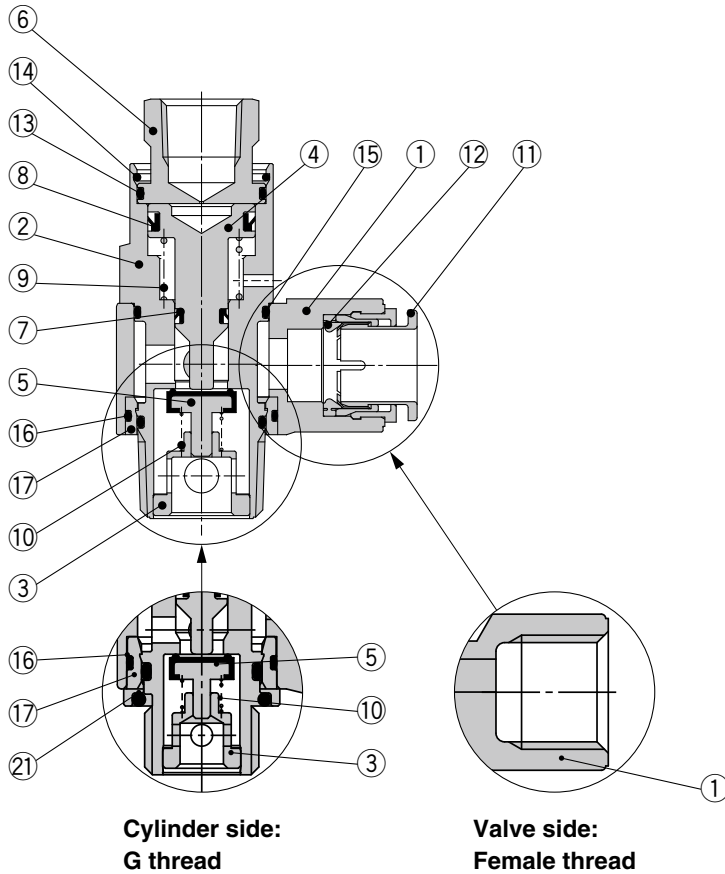

Component Parts

No.	Description	Material	Note
1	Body A	ZDC	Platinum silver
2	Pilot body	Brass	Electroless nickel plating
3	Guide	Brass	Electroless nickel plating
4	Piston	Brass	Electroless nickel plating
5	Valve	Stainless steel, NBR	
6	Cover	Brass	Electroless nickel plating
7	DY seal	NBR	
8	DY seal	NBR	
9	Spring	Stainless steel	
10	Spring	Stainless steel	
11	Cassette	—	Attached to body A for the One-touch fitting type

No.	Description	Material	Note
12	Seal	NBR	
13	O-ring	NBR	
14	Ring	Stainless steel	
15	O-ring	NBR	
16	O-ring	NBR	
17	Bushing	PBT/Brass	Brass (Electroless nickel plating) for G thread
18	O-ring	NBR	
19	Gasket	NBR	
20	Domed cap nut	Stainless steel	
21	O-ring	—	Only for G thread

AS-X785

Dimensions

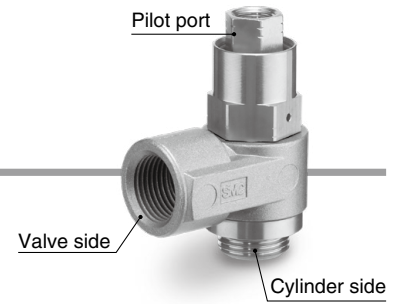

AS2200/3200/4200-□S-X785

AS2200/3200/4200-G□-X785

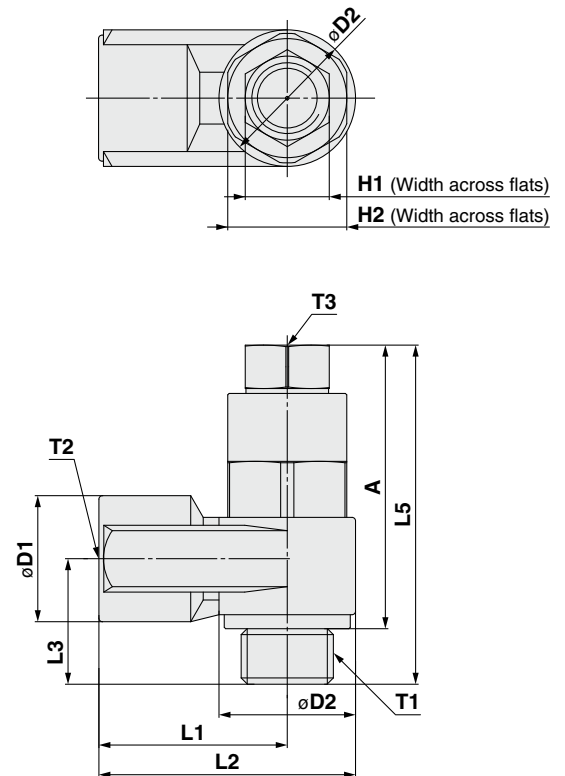
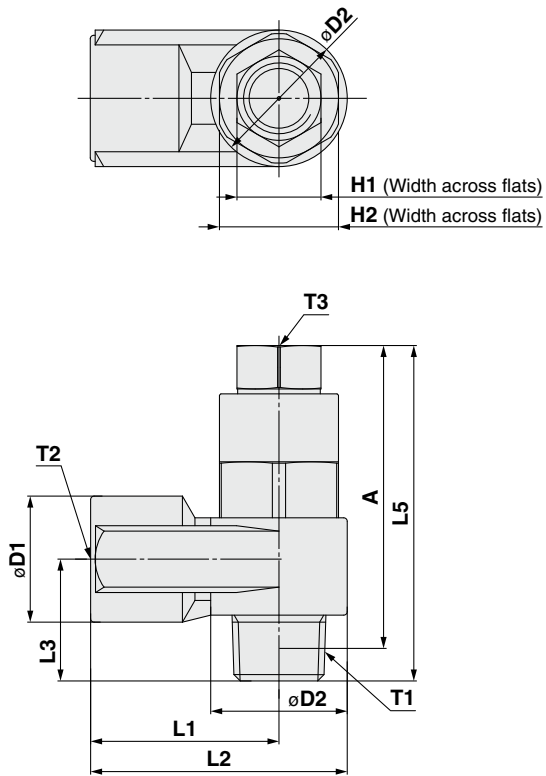

Model	T1	T2	T3	H1	H2	D1	D2	L1	L2	L3	L5	A	Weight [g]
AS2200-01S-X785	R1/8	Rc1/8	M5 x 0.8	8	12	14.3	14.6	18	25.3	14.7	39.7	35.7	35
AS2200-G01-X785	G1/8	G1/8	M5 x 0.8	8	12	14.3	14.6	18	25.3	14.7	39.7	33.8	40
AS2200-02S-X785	R1/4	Rc1/4	Rc1/8	12	17	18	19.5	27.2	36.95	18.4	48.9	42.9	77
AS2200-G02-X785	G1/4	G1/4	G1/8	12	17	18	19.5	27.2	36.95	18.5	50	41.5	85
AS3200-03S-X785	R3/8	Rc3/8	Rc1/8	12	19	22.5	24.3	30	42.15	21	56.5	50.2	125
AS3200-G03-X785	G3/8	G3/8	G1/8	12	19	22.5	24.3	30	42.15	23	58.5	48.4	140
AS4200-04S-X785	R1/2	Rc1/2	Rc1/4	17	24	27.5	28.5	38.5	52.75	27.1	70.7	62.5	225
AS4200-G04-X785	G1/2	G1/2	G1/4	17	24	27.5	28.5	38.5	52.75	28.7	72.3	60.1	250

Pilot Check Valve: Metal Body Type **AS-X785**

Dimensions

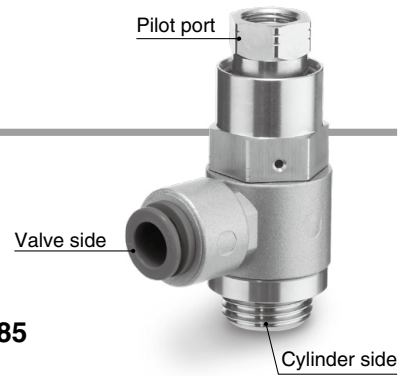

AS4201-04-F□S-X785

AS4201-G04-F□-X785

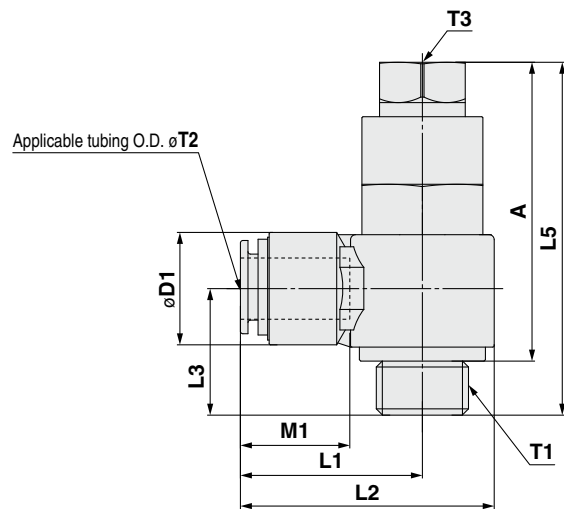
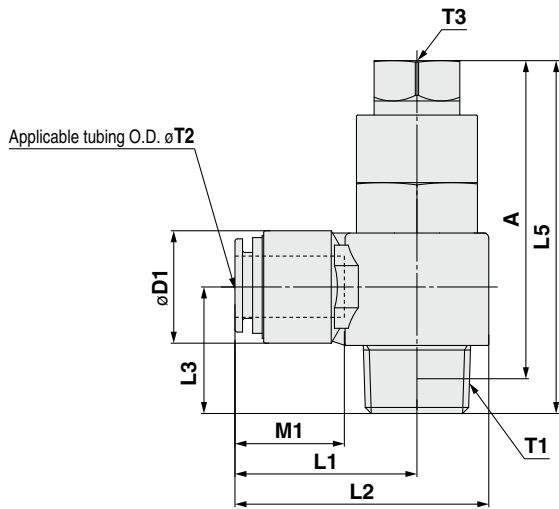
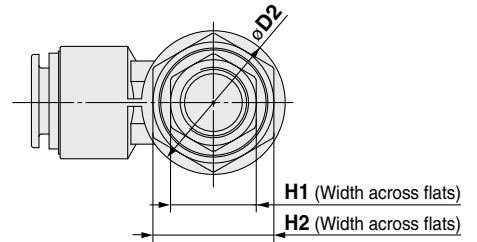
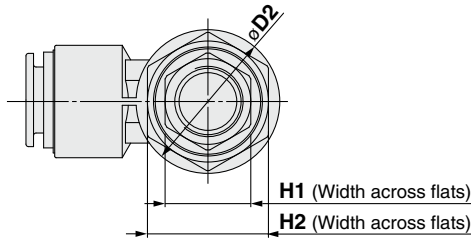

Model	T1	øT2	T3	H1	H2	D1	D2	L1	L2	L3	L5	A	M1	Weight [g]
AS4201-04-F10S-X785	R1/2	ø10	Rc1/4	17	24	22.3	28.5	36.1	50.4	25.9	70.7	62.5	21	190
AS4201-04-F12S-X785	R1/2	ø12	Rc1/4	17	24	22.3	28.5	36.1	50.4	25.9	70.7	62.5	22	183
AS4201-G04-F10-X785	G1/2	ø10	G1/4	17	24	22.3	28.5	36.1	50.4	27.5	72.3	60.1	21	215
AS4201-G04-F12-X785	G1/2	ø12	G1/4	17	24	22.3	28.5	36.1	50.4	27.5	72.3	60.1	22	208

AS-X785

Dimensions

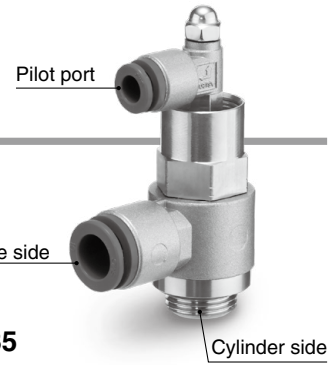

AS2201/3201-□-F□S-X785

AS2201/3201-G□-F□-X785

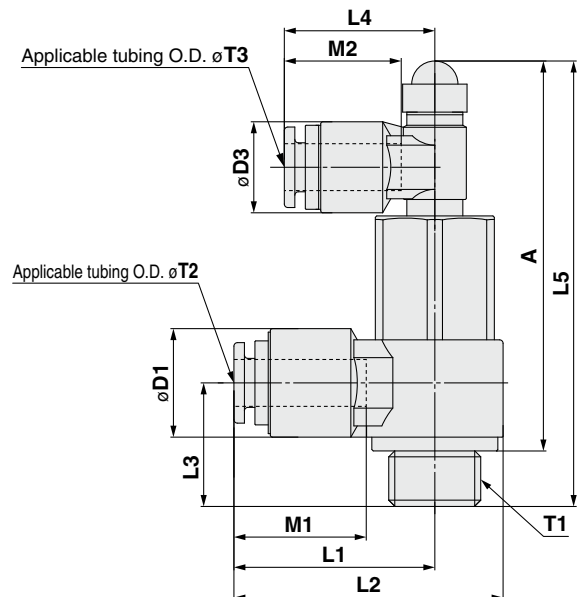
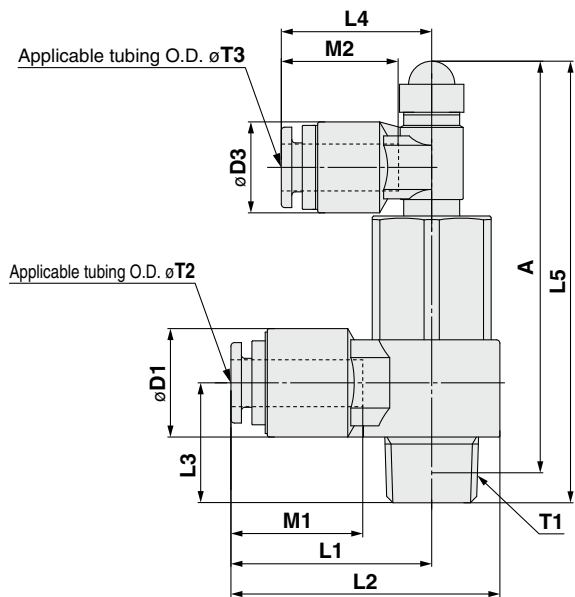
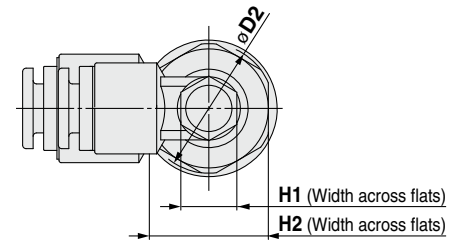
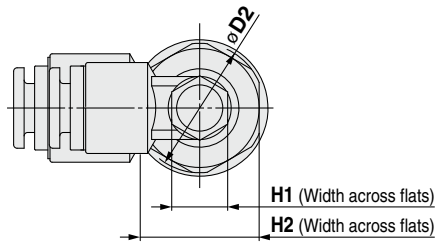

Model	T1	øT2	øT3	H1	H2	D1	D2	D3	L1	L2	L3	L4	L5	A	M1	M2	Weight [g]
AS2201-01-F06S-X785	R1/8	ø6	ø6	8	12	15.5	14.6	13	26.6	33.9	15.2	21.5	58.3	54.3	17	17	48
AS2201-01-F08S-X785	R1/8	ø8	ø6	8	12	15.5	14.6	13	26.6	33.9	15.2	21.5	58.3	54.3	18.5	17	45
AS2201-G01-F06-X785	G1/8	ø6	ø6	8	12	15.5	14.6	13	26.6	33.9	15.2	21.5	58.3	52.4	17	17	53
AS2201-G01-F08-X785	G1/8	ø8	ø6	8	12	15.5	14.6	13	26.6	33.9	15.2	21.5	58.3	52.4	18.5	17	50
AS2201-02-F06S-X785	R1/4	ø6	ø6	8	17	15.5	19.5	13	28.7	38.5	18.2	21.5	64.5	58.5	17	17	82
AS2201-02-F08S-X785	R1/4	ø8	ø6	8	17	15.5	19.5	13	28.7	38.5	18.2	21.5	64.5	58.5	18.5	17	78
AS2201-02-F10S-X785	R1/4	ø10	ø6	8	17	18.2	19.5	13	34.5	44.3	19	21.5	64.5	58.5	21	17	80
AS2201-G02-F06-X785	G1/4	ø6	ø6	8	17	15.5	19.5	13	28.7	38.5	19.3	21.5	65.6	57.1	17	17	90
AS2201-G02-F08-X785	G1/4	ø8	ø6	8	17	15.5	19.5	13	28.7	38.5	19.3	21.5	65.6	57.1	18.5	17	86
AS2201-G02-F10-X785	G1/4	ø10	ø6	8	17	18.2	19.5	13	34.5	44.3	20.1	21.5	65.6	57.1	21	17	88
AS3201-03-F08S-X785	R3/8	ø8	ø6	8	19	18	24.3	13	32.7	44.9	20.5	21.5	72.1	65.8	18.5	17	118
AS3201-03-F10S-X785	R3/8	ø10	ø6	8	19	18	24.3	13	33.3	45.5	20.5	21.5	72.1	65.8	21	17	113
AS3201-G03-F08-X785	G3/8	ø8	ø6	8	19	18	24.3	13	32.7	44.9	22.5	21.5	74.1	64	18.5	17	133
AS3201-G03-F10-X785	G3/8	ø10	ø6	8	19	18	24.3	13	33.3	44.5	22.5	21.5	74.1	64	21	17	128



AS-X785

Specific Product Precautions

Be sure to read this before handling the products. For safety instructions and flow control equipment precautions, refer to the “Handling Precautions for SMC Products” and the “Operation Manual” on the SMC website: <http://www.smcworld.com>

Design/Selection

Warning

1. **This product cannot be used for accurate and precise intermediate stops of the actuator.**

Due to the compressibility of air as a fluid, the actuator will continue to move until it reaches a position of pressure balance, even though the pilot check valve closes with an intermediate stop signal.

2. **This product cannot be used to hold a stop position for an extended period of time.**

Pilot check valves and actuators are not guaranteed for zero air leakage. Therefore, it is sometimes not possible to hold a stop position for an extended period of time. In the event that holding for an extended time is necessary, a mechanical means for holding should be devised.

3. **Consider the release of residual pressure.**

Actuators may move suddenly due to residual pressure, which can be dangerous during maintenance procedures.

4. **When used in a balance control circuit, there are instances in which the check valve cannot release, even though the pilot pressure is 50% of the operating pressure. In these cases, the pilot pressure should be the same as the operating pressure.**

5. **For reference, SMC has conducted endurance tests in which ON and OFF operation of the check valve was performed at the maximum operating pressure with a confirmed endurance of 10 million cycles. Since the tests were performed under limited conditions, use caution in evaluating the results.**

6. **The check valve has a construction in which it is closed by the differential pressure generated when the inlet pressure (IN side) or outlet pressure (OUT side) solenoid valve is switched. Be aware that the check valve does not close completely and the outlet pressure (OUT side) may drop when the inlet pressure (IN side) drops slowly and the differential pressure becomes smaller than the minimum operating pressure or cracking pressure.**

7. **Confirm the specifications.**

Products represented in this catalog are designed only for use in compressed air systems (including vacuum). Do not operate at pressures, temperatures, etc., beyond the range of specifications, as this can cause damage or malfunction. (Refer to the specifications.) Please contact SMC when using a fluid other than compressed air (including vacuum). We do not guarantee against any damage if the product is used outside of the specification range.

Installation

Warning

1. **When mounting, firmly align the tool to be used with the hexagonal portion of the pilot body. If the hexagonal portion is damaged as a result of failure to properly align the tool, the pilot body will be deformed, and poor pilot operation may result.**
2. **Do not use fittings for applications involving continuous rotation. The product may be damaged.**

Air Source

Warning

1. **If moisture enters the inside of the connected piping, the cover may corrode, leading to a pilot operation malfunction.**

2. **When there is a large amount of drainage**

Compressed air containing a large amount of drainage can cause the malfunction of pneumatic equipment. An air dryer or water separator should be installed upstream from filters.

Caution

1. **Install an air filter.**

Install an air filter upstream near the valve. Select an air filter with a filtration size of 5 µm or smaller.

Operating Environment

Warning

1. **Do not use in an atmosphere containing corrosive gases, chemicals, sea water, water, water steam, or where there is direct contact with any of these.**

Refer to each construction drawing for information on the materials of flow control equipment.

2. **Do not expose the product to direct sunlight for an extended period of time.**
3. **Do not use in a place subject to heavy vibration and/or shock.**
4. **Do not mount the product in locations where it is exposed to radiant heat.**

Maintenance

Warning

1. **Perform maintenance inspections according to the procedures indicated in the operation manual.**

If handled improperly, malfunction or damage of machinery and equipment may occur.

2. **Maintenance work**

If handled improperly, compressed air can be dangerous. Assembly, handling, repair, and element replacement of pneumatic systems should be performed by a knowledgeable and experienced person.

3. **Drain flushing**

Remove drainage from air filters regularly.

4. **Removal of equipment, and supply/exhaust of compressed air**

Before components are removed, first confirm that measures are in place to prevent workpieces from dropping, run-away equipment, etc. Then, cut off the supply pressure and electric power, and exhaust all compressed air from the system using the residual pressure release function.

When machinery is restarted, proceed with caution after confirming that appropriate measures are in place to prevent sudden movement.

 **Safety Instructions** Be sure to read the “Handling Precautions for SMC Products” (M-E03-3) and “Operation Manual” before use.