

Air Cylinder: Standard Type Double Acting, Double Rod

CS2W Series

RoHS

ø125, ø140, ø160, ø180, ø200, ø250, ø320

How to Order

CS2W L 125 - 100 -

With auto switch CDS2W L 125 - 100 - M9BW -

With auto switch (Built-in magnet)

Double rod type

Mounting

B	Basic
L	Foot
F	Flange
T	Center trunnion

Bore size

125	125 mm
140	140 mm
160	160 mm
180	180 mm
200	200 mm
250	250 mm
320	320 mm

Port thread type

Nil	Rc
TN	NPT
TF	G

Cylinder stroke [mm]
Refer to "Maximum Strokes" on page 28.

Made to order
Refer to page 28 for details.

Number of auto switches

Nil	2
3	3
S	1
n	n

Auto switch

Nil	Without auto switch
------------	---------------------

* For applicable auto switches, refer to the table below.

Suffix for cylinder

Single side rod boot	J	Nylon tarpaulin
	K	Heat-resistant tarpaulin
Both side rod boot	JJ	Nylon tarpaulin
	KK	Heat-resistant tarpaulin

* The minimum stroke with a rod boot is 30 mm. (35 mm for ø160 when the center trunnion type is selected)

Built-in Magnet Cylinder Model

If a built-in magnet cylinder without an auto switch is required, there is no need to enter the symbol for the auto switch.
(Example) CDS2WB125-100

Applicable Auto Switches/Refer to the Web Catalog for further information on auto switches.

Type	Special function	Electrical entry	Indicator light	Wiring (Output)	Load voltage		Auto switch model		Lead wire length [m]				Pre-wired connector	Applicable load		
					DC	AC	Tie-rod mounting	Band mounting	0.5 (Nil)	1 (M)	3 (L)	5 (Z)				
Solid state auto switch	—	Grommet	No	3-wire (NPN)	24 V	5 V, 12 V	—	M9N	—	●	●	●	○	○	IC circuit	
				3-wire (PNP)				M9P	—	●	●	●	○	○		
		2-wire		M9B	—	●	●	●	○	○	—					
		Terminal conduit		3-wire (NPN)	24 V	5 V, 12 V	—	G39	—	—	—	—	—	—	—	—
	2-wire		K39	—				—	—	—	—	—				
	Diagnostic indication (2-color indicator)	Grommet	Yes	3-wire (NPN)	24 V	5 V, 12 V	—	M9NW	—	●	●	●	○	○	IC circuit	
				3-wire (PNP)				M9PW	—	●	●	●	○	○		
	Water resistant (2-color indicator)	Grommet	No	2-wire	24 V	12 V	—	M9BW	—	●	●	●	○	○	—	
				3-wire (NPN)				M9NA *1	—	○	○	●	○	○		
	With diagnostic output (2-color indicator)	Grommet	No	3-wire (PNP)	24 V	12 V	—	M9PA *1	—	○	○	●	○	○	IC circuit	
2-wire				M9BA *1				—	○	○	●	○	○			
Magnetic field resistant (2-color indicator)	Grommet	No	4-wire (NPN)	24 V	5 V, 12 V	—	F59F	—	●	—	●	○	○	IC circuit		
			2-wire (Non-polar)				P3DWA *2	—	●	—	●	●	○			
Reed auto switch	—	Grommet	Yes	3-wire (NPN equivalent)	24 V	12 V	100 V	A96	—	●	—	●	—	—	IC circuit	
								A93	—	●	●	●	—	—		
								A90	—	●	—	—	—	—		
								A54	—	●	—	●	●	—		
								A64	—	●	—	●	—	—		
		Terminal conduit	No	2-wire	24 V	12 V	—	—	A33	—	—	—	—	—	—	—
									A34	—	—	—	—	—		
									A44	—	—	—	—	—		
									A59W	—	●	—	●	—		
									A59W	—	●	—	●	—		
DIN terminal	Yes	2-wire	24 V	100 V, 200 V	—	—	A33	—	—	—	—	—	—			
							A34	—	—	—	—	—				
Diagnostic indication (2-color indicator)	Grommet	No	2-wire	24 V	100 V, 200 V	—	A33	—	—	—	—	—	—			
							A34	—	—	—	—	—				

*1 Water-resistant type auto switches can be mounted on the above models, but SMC cannot guarantee water resistance.

Please contact SMC regarding water-resistant types with the above model numbers.

*2 The D-P3DWA, A54, A64, and A59W are not applicable to bore sizes ø250 and ø320.

* Lead wire length symbols: 0.5 m..... Nil (Example) M9NW 3 m..... L (Example) M9NWL
1 m..... M (Example) M9NWM 5 m..... Z (Example) M9NWZ

* Solid state auto switches marked with a "O" are produced upon receipt of order.

* Since there are applicable auto switches other than those listed above, refer to page 63 for details.

* D-A9□/M9□/M9□W/M9□A/P3DWA□ auto switches are shipped together with the product but do not come assembled. (Only the auto switch mounting brackets are assembled before shipment.)

* D-G39/K39/A3□/A44 auto switches (band mounting type) can only be mounted on ø125 to ø160.

Air Cylinder: Standard Type **CS2W Series**

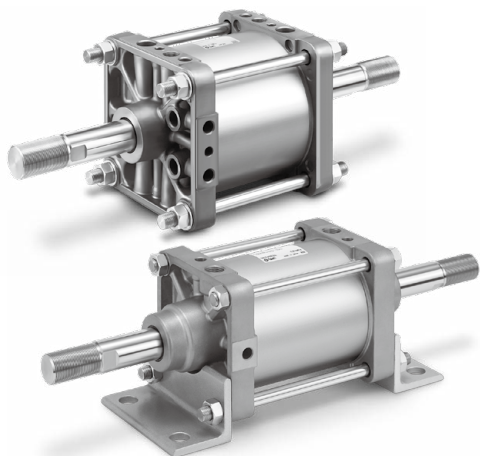

Symbol

Double acting, Air cushion

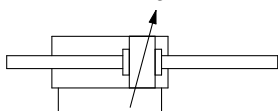

Made to Order Common Specifications
(For details, refer to pages 65 to 75.)

Symbol	Specifications
-XA□	Change of rod end shape
-XB6	Heat-resistant cylinder (0 to 150°C)
-XC4	With heavy duty scraper
-XC5	Heat-resistant cylinder (0 to 110°C)
-XC14	Change of trunnion bracket mounting position
-XC15	Change of tie-rod length
-XC22	Fluororubber seal
-XC30	Rod side trunnion
-XC35	With coil scraper
-XC68	Made of stainless steel (With hard chrome plated piston rod)

* Refer to page 5 for details on whether or not to use a made-to-order product with the above common specifications.

Refer to pages 59 to 63 for cylinders with auto switches.

- Auto Switch Proper Mounting Position (Detection at Stroke End) and Mounting Height
- Minimum Stroke for Auto Switch Mounting
- Operating Range
- Auto Switch Mounting Brackets/Part Nos.

Specifications

Bore size [mm]	125	140	160	180	200	250	320
Action	Double acting, Double rod						
Fluid	Air						
Proof pressure	1.57 MPa			1.2 MPa			
Max. operating pressure	0.97 MPa			0.7 MPa			
Min. operating pressure	0.05 MPa						
Piston speed	50 to 500 mm/s			50 to 300 mm/s			
Cushion	Air cushion			Air cushion + Bumper cushion			
Ambient and fluid temperatures	Without auto switch	0 to 70°C (No freezing)					
	With auto switch	0 to 60°C (No freezing)					
Lubrication	Not required (Non-lube)						
Stroke length tolerance [mm]	250 or less	+1.0 0					+2.0 0
	251 to 1000	+1.4 0					+2.4 0
	1001 to 1200	—		+1.8 0		+2.8 0	
Mounting	Basic, Foot, Flange, Center trunnion						
Allowable kinetic energy (When air cushion is activated)	32.3 J	44.6 J	58.8 J	78.4 J	98 J	147 J	265 J

Maximum Strokes

* When using with auto switches, refer to the "Minimum Stroke for Auto Switch Mounting" table on page 61.

Bore size	Maximum stroke [mm]
125, 140	1000 or less
160, 180	1200 or less
200	998 or less
250	813 or less
320	495 or less

* Bore sizes $\phi 200$ to $\phi 320$ with strokes which exceed the above-mentioned strokes (up to 1200 mm) are available as a special product. **However, this excludes class 2 pressure vessels which are to be used or installed in Japan.**

Accessories

Mounting		Basic	Foot	Flange	Center trunnion
Option	Rod end nut	●	●	●	●
	Single knuckle joint	●	●	●	●
	Double knuckle joint (Knuckle pin, Split pin)	●	●	●	●
	Rod boot	●	●	●	●

* If using the rod end nut with a single knuckle joint or a double knuckle joint, please refer to page 26.

Mounting Bracket Part Nos.

Bore size [mm]	125	140	160	180	200	250	320
Foot*1	CS2-L12	CS2-L14	CS2-L16	CS2-L18	CS2-L20	CS2-L25	CS2-L32
Flange	CS2-F12	CS2-F14	CS2-F16	CS2-F18	CS2-F20	CS2-F25	CS2-F32

*1 When ordering foot brackets, order two pieces per cylinder.
* Mounting nuts are included in the brackets for bore size $\phi 320$.

Rod Boot Material

Symbol	Material	Max. ambient temp.
J	Nylon tarpaulin	70°C
K	Heat-resistant tarpaulin	110°C*1

*1 Max. ambient temperature for rod boot itself

Standard Double Acting, Single Rod **CS2**
 Double Acting, Double Rod **CS2W**
 Long Stroke Double Acting, Single Rod **CS2-V**
 Axial Centralized Piping Double Acting, Single Rod **CS2-P**

Auto Switch

Made to Order

CS2W Series

Weight (Guide)

Bore size [mm]		125	140	160	180	200	250	320
Basic weight	Basic	6.4	7.6	10.0	12.6	16.8	29.4	54.6
	Foot	8.4	10.6	13.4	17.4	22.3	40.4	80.4
	Flange	9.5	13.1	16.7	22.3	28.6	51.2	92.6
	Trunnion	10.5	13.3	16.4	23.3	30.8	55.7	89.1
Additional weight with magnet (With built-in magnet and auto switch)		0.1	0.1	0.1	0.1	0.2	0.2	0.3
Additional weight per 100 mm of stroke		2.2	2.3	3.2	3.5	4.3	7.1	9.7
Accessories	Single knuckle	1.0	1.2	1.6	3.1	3.0	5.4	10.8
	Double knuckle (Knuckle pin, Split pin)	1.4	1.9	2.5	4.8	4.6	9.3	17.2
	Rod end nut	0.2	0.2	0.3	0.4	0.9	1.3	1.4

Calculation: (Example) **CS2WL160-500**

- Basic weight 13.4 [kg]
 - Additional weight ... 3.2 [kg/100 mm]
 - Cylinder stroke 500 [mm]
- $$13.4 + 3.2 \times 500/100 = 29.4 \text{ [kg]}$$

Theoretical Output



Unit: N

Bore size [mm]	Rod size [mm]	Piston area [mm ²]	Operating pressure [MPa]								
			0.2	0.3	0.4	0.5	0.6	0.7	0.8	0.9	1.0
125	32	11500	2300	3450	4600	5750	6900	8050	9200	10350	11500
140		14600	2920	4380	5840	7300	8760	10220	11680	13140	14600
160	38	19000	3800	5700	7600	9500	11400	13300	15200	17100	19000
180	40	24200	4840	7260	9680	12100	14520	16940	—	—	—
200	45	29800	5960	8940	11920	14900	17880	20860	—	—	—
250	56	46600	9320	13980	18640	23300	27960	32620	—	—	—
320	65	77100	15400	23100	30800	38600	46300	54000	—	—	—

Construction

ø125 to ø160

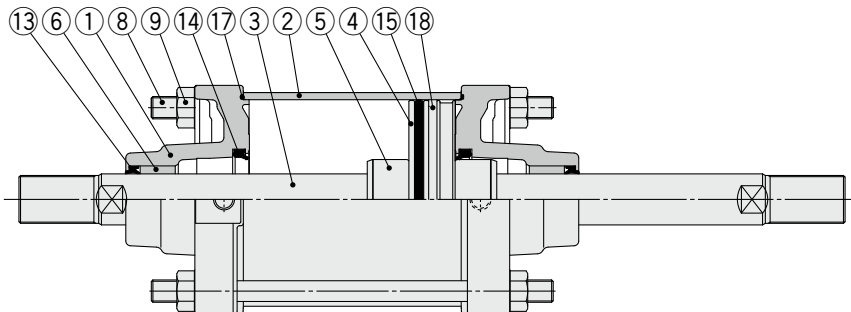
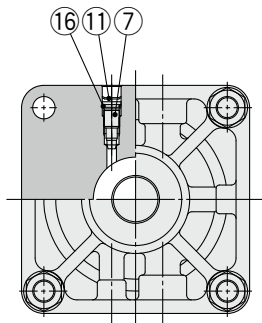

ø180 to ø250

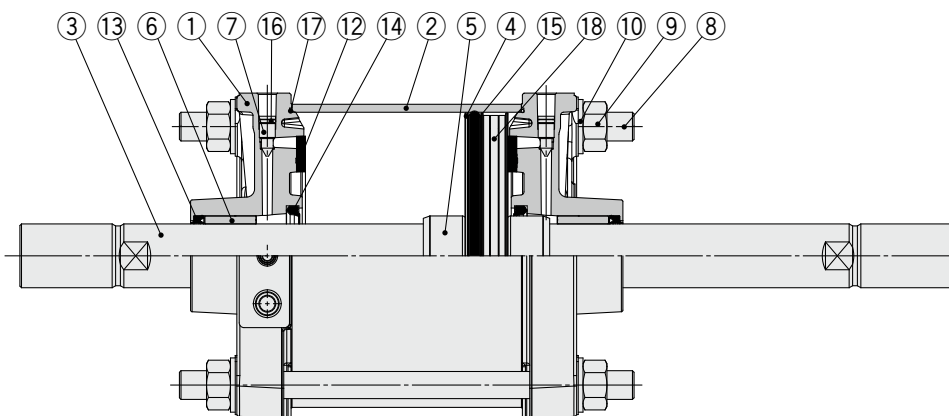
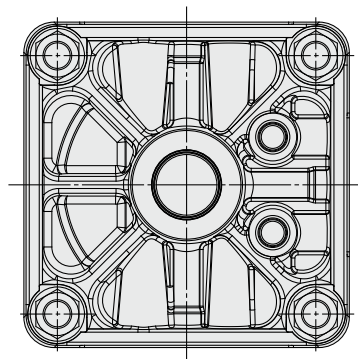

Component Parts

No.	Description	Material	Qty.	Note
1	Rod cover	Aluminum die-cast	2	
2	Cylinder tube	Aluminum alloy	1	
3	Piston rod	Carbon steel	1	
4	Piston	Aluminum alloy	1	
5	Cushion ring	Stainless steel	2	ø125 to ø180
		Rolled steel	2	ø200, ø250
6	Bushing	Bearing alloy	2	
7	Cushion valve	Rolled steel	2	ø125 to ø160
		Brass	2	ø180 to ø250
8	Tie-rod	Carbon steel	4	
9	Tie-rod nut	Rolled steel	8	
10	Flat washer	Rolled steel	8	ø180 to ø250
11	Retaining ring	Spring steel	2	ø125 to ø160
12	Bumper	Urethane	2	ø180 to ø250
13	Rod seal	NBR	2	
14	Cushion seal	Urethane	2	ø125 to ø200
		NBR	2	ø250

Component Parts

No.	Description	Material	Qty.	Note
15	Piston seal	NBR	1	
16	Cushion valve seal	NBR	2	
17	Cylinder tube gasket	NBR	2	
18	Magnet	—	1	

Replacement Parts/Seal Kit

Bore size [mm]	Kit no.	Contents
125	CS2W125A-PS	Set of nos. 13, 14, 15, 17
140	CS2W140A-PS	
160	CS2W160A-PS	

- * The seal kit includes a grease pack (40 g). Order with one of the following part numbers when only the grease pack is required.
Grease pack part number: GR-S-010 (10 g), GR-S-020 (20 g)
- * Refer to page 31 for bore size ø320 replacement parts/seal kit.
- * Do not remove the rod seal of bore sizes ø180 to ø250 because it is a non-replaceable part.
- * Refer to page 76 for precautions when replacing the seal.
- * Please contact SMC to order the common made-to-order specification -XA□ (Change of rod end shape), in which the seal of bore sizes ø180 to ø250 can be replaced.
- * Trunnion type should not be disassembled. (Refer to page 76.)

Standard Double Acting, Single Rod **CS2**
Double Acting, Double Rod **CS2W**
Long Stroke Double Acting, Single Rod **CS2-V**
Axial Centralized Piping Double Acting, Single Rod **CS2□P**
Auto Switch
Made to Order

CS2W Series

Construction

ø320

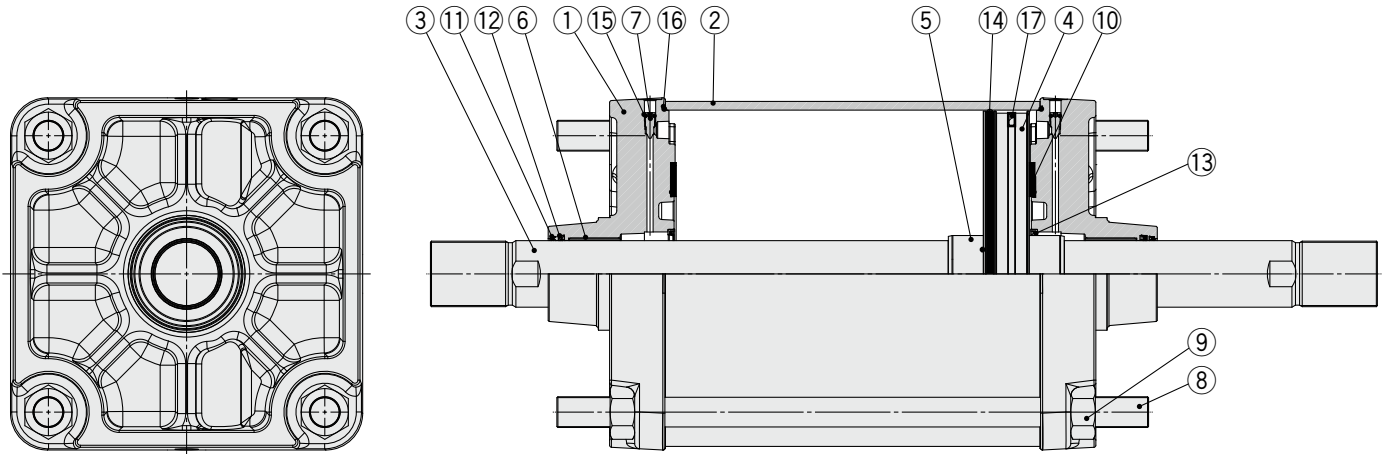

Component Parts

No.	Description	Material	Qty.
1	Rod cover	Aluminum casted	2
2	Cylinder tube	Aluminum alloy	1
3	Piston rod	Carbon steel	1
4	Piston	Aluminum alloy	1
5	Cushion ring	Rolled steel	2
6	Bushing	Bearing alloy	2
7	Cushion valve	Brass	2
8	Tie-rod	Carbon steel	4
9	Tie-rod nut	Rolled steel	8
10	Bumper	Urethane	2
11	Scraper	NBR	2
12	Rod seal	NBR	2

Component Parts

No.	Description	Material	Qty.
13	Cushion seal	NBR	2
14	Piston seal	NBR	1
15	Cushion valve seal	NBR	2
16	Cylinder tube gasket	NBR	2
17	Plastic magnet	—	(1)

Replacement Parts/Seal Kit

Bore size [mm]	Kit no.	Contents
320	CS2W320A-PS	Set of nos. ⑪, ⑫, ⑭, ⑯

* The seal kit includes a grease pack (40 g). Order with one of the following part numbers when only the grease pack is required.
Grease pack part number: GR-S-010 (10 g), GR-S-020 (20 g)

Dimensions

Basic: CS2WB
ø125 to ø160

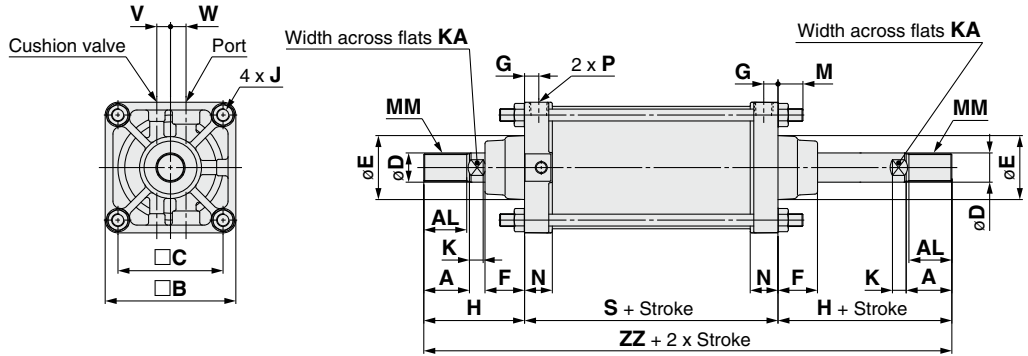

With rod boot (One side)

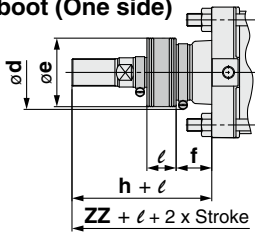

With rod boot (Both sides)

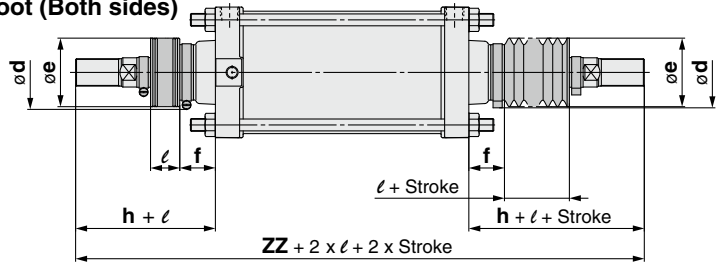

Bore size	Stroke range	A	AL	B	C	D	E	F	G	J	V	W	K	KA	M	MM	N	P	S
125	Up to 1000	50	47	143	115	32	71	43	15	M14 x 1.5	15	17	15	27	27	M30 x 1.5	30.5	1/2	98
140	Up to 1000	50	47	157	128	32	71	43	15	M14 x 1.5	15	17	15	27	27	M30 x 1.5	30.5	1/2	98
160	Up to 1200	56	53	177	144	38	78.5	42	18	M16 x 1.5	15	20	17	34	30.5	M36 x 1.5	34.5	3/4	106

Bore size	Without rod boot		With rod boot (One side)						(Both sides)	
	H	ZZ	d	e	f	h	l	ZZ	ZZ	
125	110	318	82	75	40	133	1/5 stroke	341	364	
140	110	318	82	75	40	133	1/5 stroke	341	364	
160	120	346	82	75	40	141	1/5 stroke	367	388	

ø180 to ø250

With rod boot

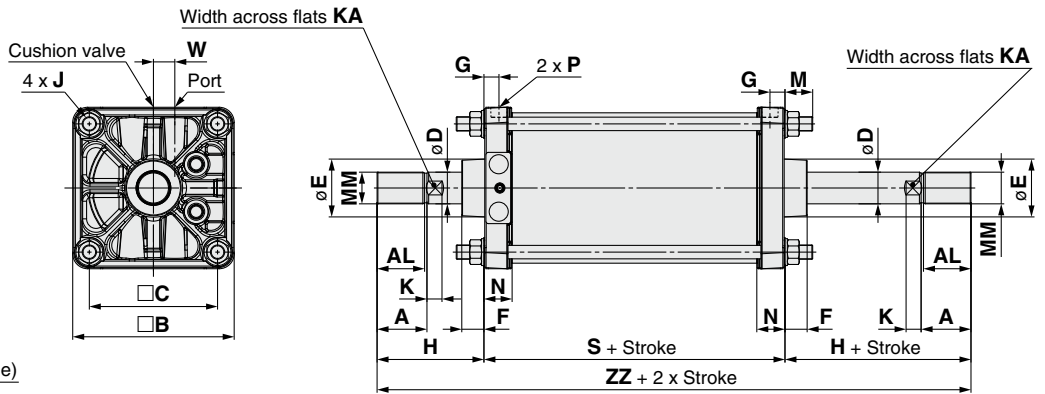
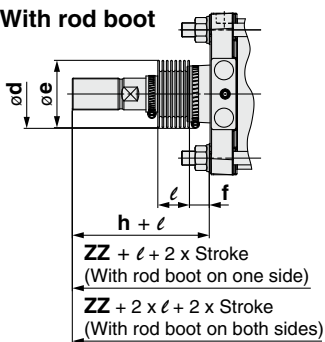

Bore size	Stroke range	A	AL	B	C	D	E	F	G	J	K	KA	M	MM	N	P	S	W
180	Up to 1200	63	60	204	162	40	73	28	19	M18 x 1.5	17	36	35	M40 x 1.5	35.6	1/2	115	27
200	Up to 998	63	60	226	182	45	78.5	32	19	M20 x 1.5	20	41	35	M45 x 1.5	35.6	1/2	120	27
250	Up to 813	71	67	277	225	56	91	43	23	M24 x 1.5	22	50	41.5	M56 x 2	45.6	3/4	141	32

Bore size	Without rod boot		With rod boot (One side)						(Both sides)	
	H	ZZ	d	e	f	h	l	ZZ	ZZ	
180	135	385	92	85	25	153	1/5 stroke	403	421	
200	135	390	96	90	29	153	1/5 stroke	408	426	
250	160	461	108	105	36	176	1/6 stroke	477	493	

Standard Double Acting, Single Rod **CS2**

Double Acting, Double Rod **CS2W**

Long Stroke Double Acting, Single Rod **CS2-V**

Axial Centralized Piping Double Acting, Single Rod **CS2-P**

Auto Switch

Made to Order

CS2W Series

Dimensions

Basic: CS2WB

ø320

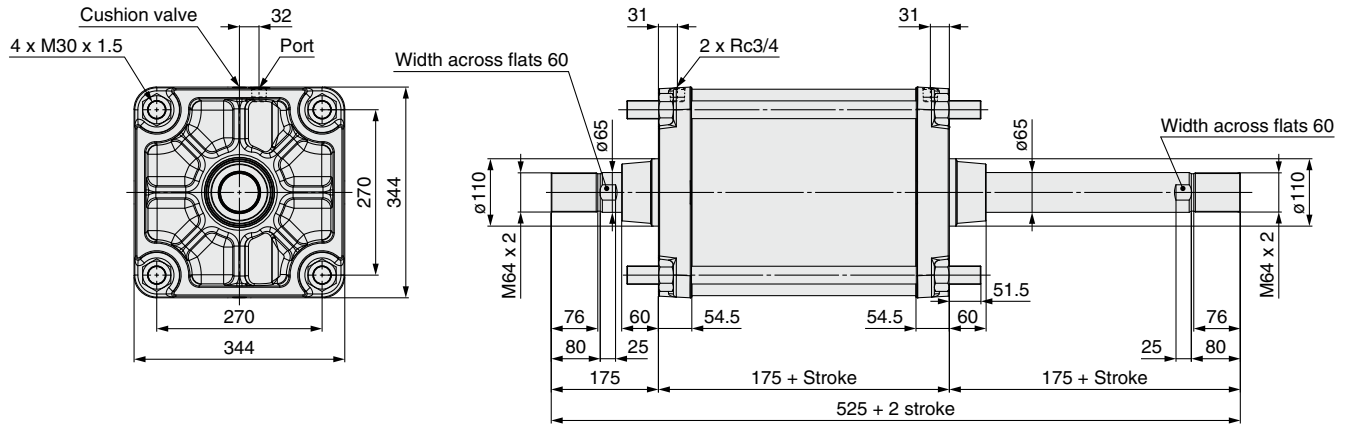

With rod boot

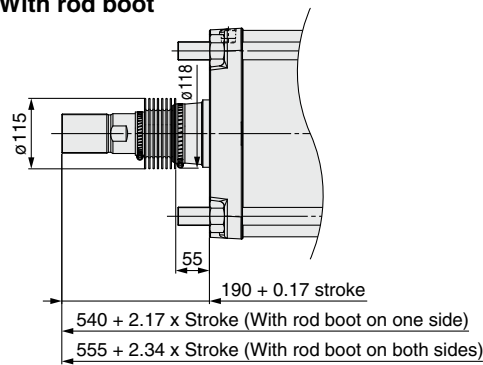

Dimensions

Foot: CS2WL
ø125 to ø160

With rod boot

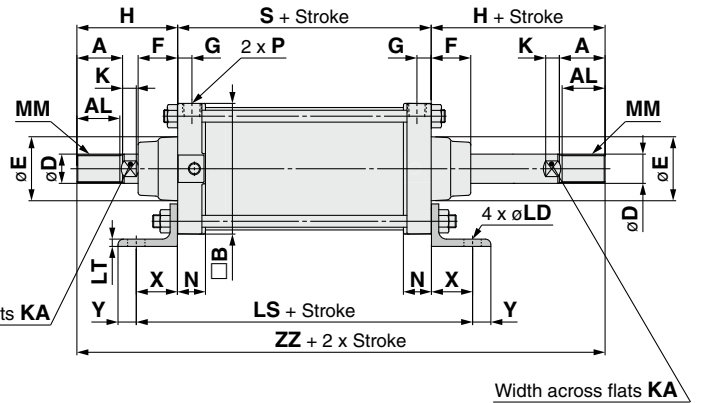
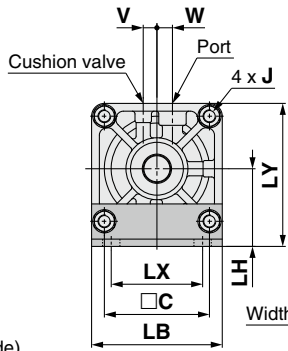
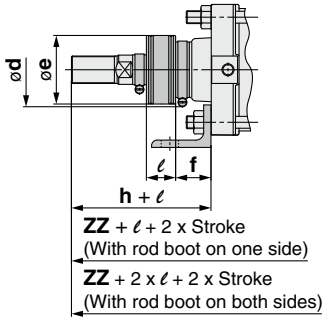

Bore size	Stroke range	A	AL	B	C	D	E	F	G	J	V	W	K	KA	LB	LD	LH	LS	LT	LX	LY
125	Up to 1000	50	47	143	115	32	71	43	15	M14 x 1.5	15	17	15	27	143	19	85	188	8	100	156.5
140	Up to 1000	50	47	157	128	32	71	43	15	M14 x 1.5	15	17	15	27	157	19	100	188	9	112	178.5
160	Up to 1200	56	53	177	144	38	78.5	42	18	M16 x 1.5	15	20	17	34	177	19	106	206	9	118	194.5

Bore size	MM	N	P	S	X	Y	Without rod boot		With rod boot (One side)				With rod boot (Both sides)	
							H	ZZ	e	f	h	l	ZZ	ZZ
125	M30 x 1.5	30.5	1/2	98	45	20	110	318	75	40	133	1/5 stroke	341	364
140	M30 x 1.5	30.5	1/2	98	45	30	110	318	75	40	133	1/5 stroke	341	364
160	M36 x 1.5	34.5	3/4	106	50	25	120	346	75	40	141	1/5 stroke	367	388

ø180 to ø250

With rod boot

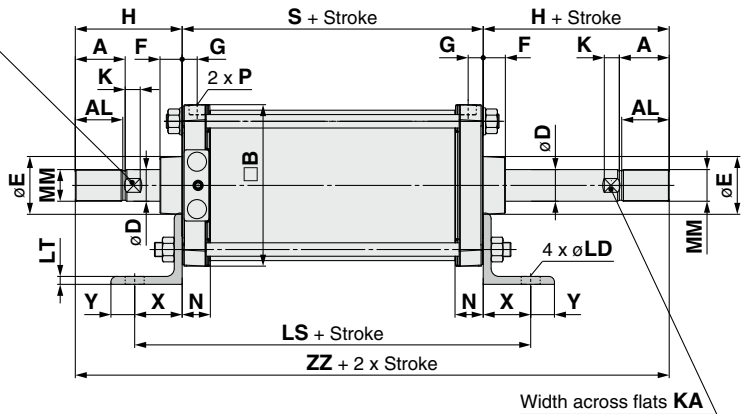
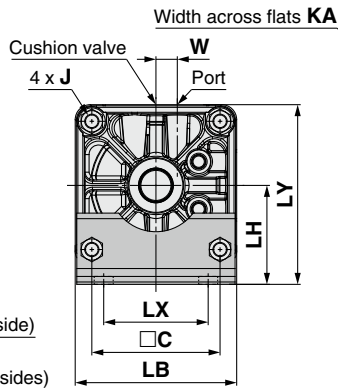
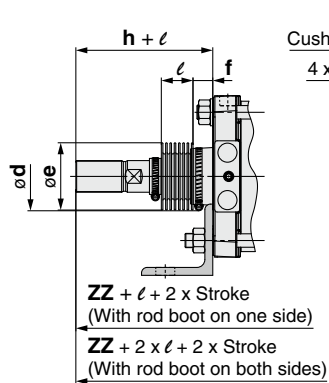

Bore size	Stroke range	A	AL	B	C	D	E	F	G	J	K	KA	LB	LD	LH	LS	LT	LX	LY
180	Up to 1200	63	60	204	162	40	73	28	19	M18 x 1.5	17	36	200	24	125	235	10	132	227
200	Up to 998	63	60	226	182	45	78.5	32	19	M20 x 1.5	20	41	225	24	132	240	10	150	245
250	Up to 813	71	67	277	225	56	91	43	23	M24 x 1.5	22	50	275	29	160	301	12	180	298.5

Bore size	MM	N	P	S	W	X	Y	Without rod boot		With rod boot (One side)				With rod boot (Both sides)		
								H	ZZ	d	e	f	h	l	ZZ	ZZ
180	M40 x 1.5	35.6	1/2	115	27	60	30	135	385	92	85	25	153	1/5 stroke	403	421
200	M45 x 1.5	35.6	1/2	120	27	60	30	135	390	96	90	29	153	1/5 stroke	408	426
250	M56 x 2	45.6	3/4	141	32	80	40	160	461	108	105	36	176	1/6 stroke	477	493

Standard Double Acting, Single Rod CS2
Double Acting, Double Rod CS2W
Long Stroke Double Acting, Single Rod CS2-V
Axial Centralized Piping Double Acting, Single Rod CS2-P
Auto Switch
Made to Order

CS2W Series

Dimensions

Foot: CS2WL

ø320

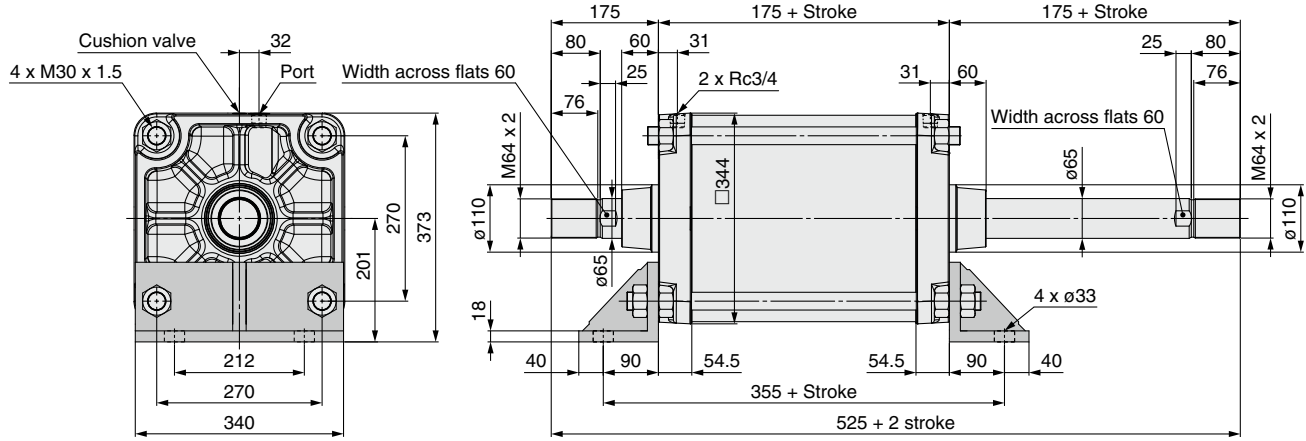

With rod boot

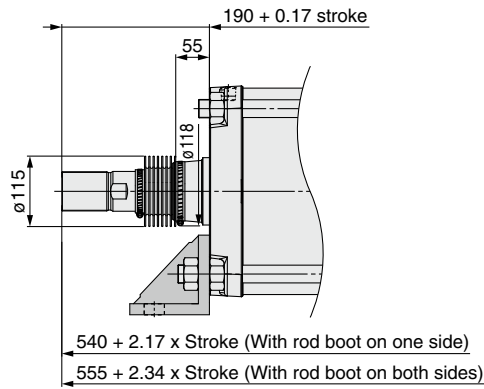

Dimensions

Flange: CS2WF

ø125 to ø160

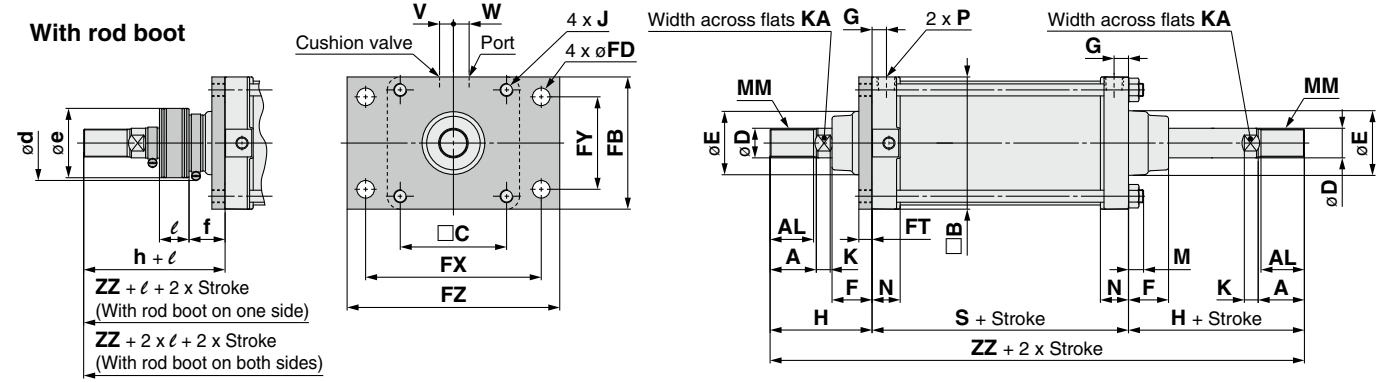

Bore size	Stroke range	A	AL	B	C	D	E	F	FB	FD	FT	FX	FY	FZ	G	J	V	W	K	KA	M
125	Up to 1000	50	47	143	115	32	71	43	145	19	14	190	100	230	15	M14 x 1.5	15	17	15	27	13
140	Up to 1000	50	47	157	128	32	71	43	160	19	20	212	112	255	15	M14 x 1.5	15	17	15	27	13
160	Up to 1200	56	53	177	144	38	78.5	42	180	19	20	236	118	275	18	M16 x 1.5	15	20	17	34	15

Bore size	MM	N	P	S	Without rod boot		With rod boot (One side)							With rod boot (Both sides)	
					H	ZZ	d	e	f	h	l	ZZ	ZZ		
125	M30 x 1.5	30.5	1/2	98	110	318	82	75	40	133	1/5 stroke	341	364		
140	M30 x 1.5	30.5	1/2	98	110	318	82	75	40	133	1/5 stroke	341	364		
160	M36 x 1.5	34.5	3/4	106	120	346	82	75	40	141	1/5 stroke	367	388		

ø180 to ø250

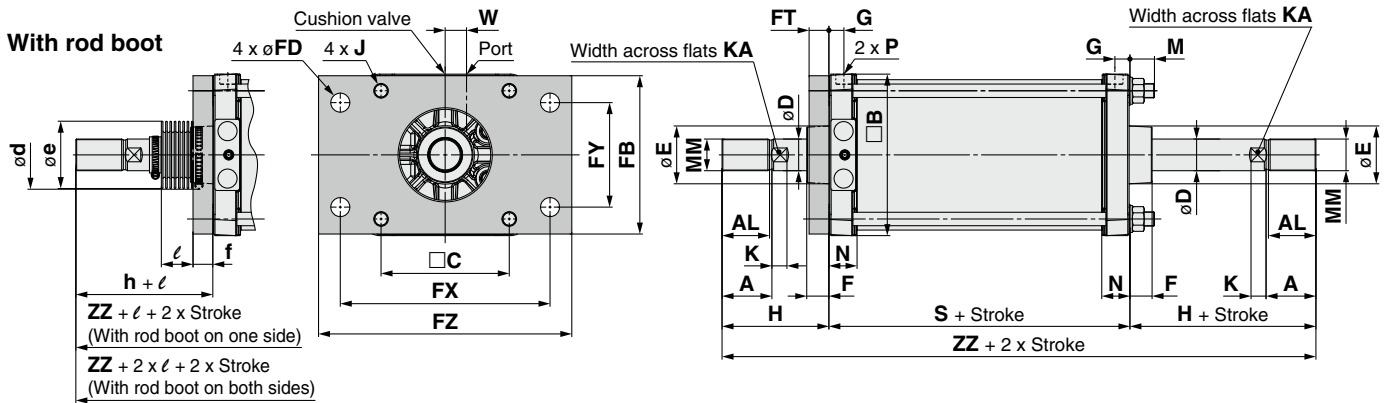

Bore size	Stroke range	A	AL	B	C	D	E	F	FB	FD	FT	FX	FY	FZ	G	J	K	KA	M
180	Up to 1200	63	60	204	162	40	73	28	200	24	25	265	132	320	19	M18 x 1.5	17	36	31
200	Up to 998	63	60	226	182	45	78.5	32	225	24	25	280	150	335	19	M20 x 1.5	20	41	31
250	Up to 813	71	67	277	225	56	91	43	275	29	30	355	180	420	23	M24 x 1.5	22	50	35

Bore size	MM	N	P	S	W	Without rod boot		With rod boot (One side)							With rod boot (Both sides)	
						H	ZZ	d	e	f	h	l	ZZ	ZZ		
180	M40 x 1.5	35.6	1/2	115	27	135	385	92	85	25	153	1/5 stroke	403	421		
200	M45 x 1.5	35.6	1/2	120	27	135	390	96	90	29	153	1/5 stroke	408	426		
250	M56 x 2	45.6	3/4	141	32	160	461	108	105	36	176	1/6 stroke	477	493		

Standard Double Acting, Single Rod **CS2**

Double Acting, Double Rod **CS2W**

Long Stroke Double Acting, Single Rod **CS2-V**

Axial Centralized Piping Double Acting, Single Rod **CS2□P**

Auto Switch

Made to Order

CS2W Series

Dimensions

Flange: CS2WF

ø320

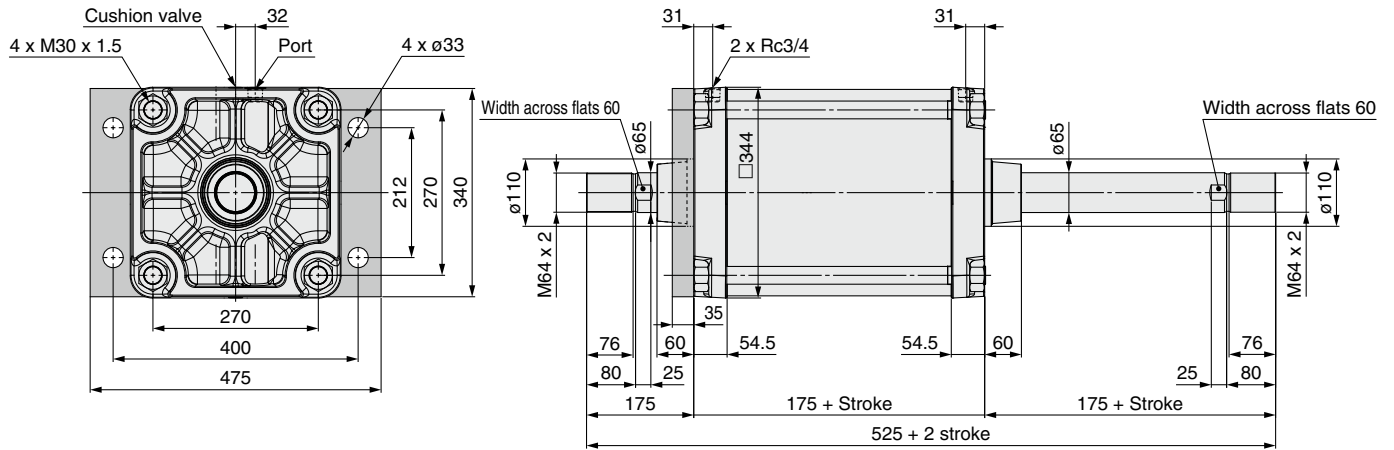

With rod boot

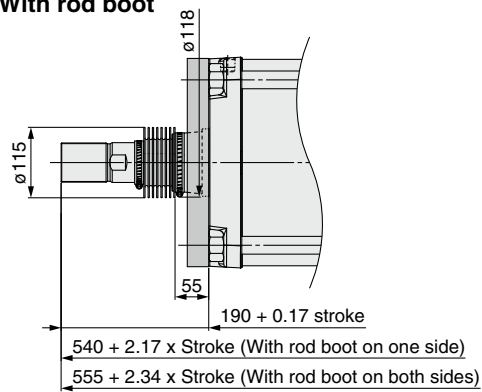

Dimensions

Center trunnion: CS2WT

ø125 to ø160

With rod boot

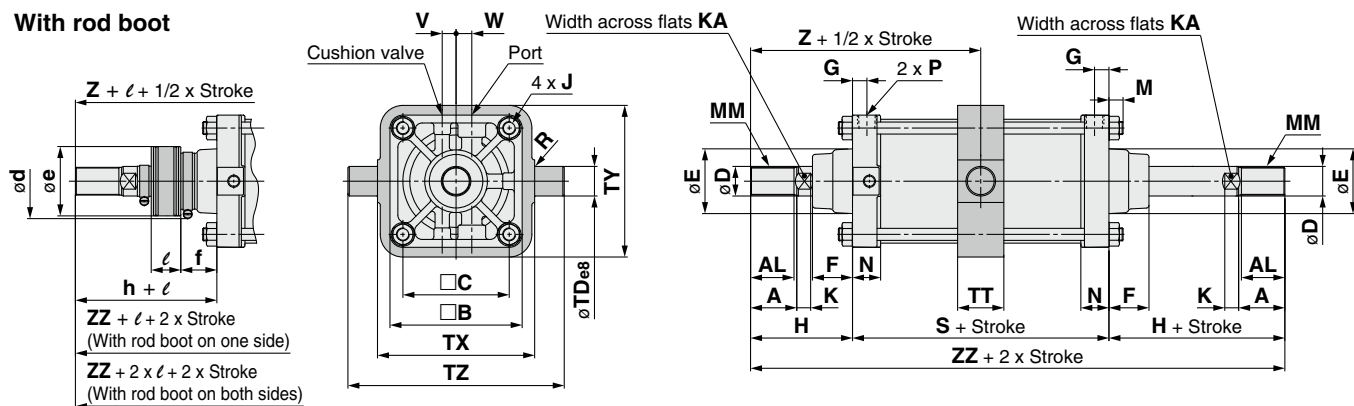

Bore size	Stroke range	A	AL	B	C	D	E	F	G	J	V	W	K	KA	M	MM	N	P	R	S
125	25 to 1000	50	47	143	115	32	71	43	15	M14 x 1.5	15	17	15	27	13	M30 x 1.5	30.5	1/2	1	98
140	30 to 1000	50	47	157	128	32	71	43	15	M14 x 1.5	15	17	15	27	13	M30 x 1.5	30.5	1/2	1.5	98
160	35 to 1200	56	53	177	144	38	78.5	42	18	M16 x 1.5	15	20	17	34	15	M36 x 1.5	34.5	3/4	1.5	106

Bore size	TDe8	TT	TX	TY	TZ	Without rod boot			With rod boot (One side)										(Both sides)		
						H	Z	ZZ	d	e	f	h	l	Z	ZZ	ZZ					
125	32 ^{-0.050} _{-0.089}	50	170	164	234	110	159	318	82	75	40	133	1/5 stroke	182	341	364					
140	36 ^{-0.050} _{-0.089}	55	190	184	262	110	159	318	82	75	40	133	1/5 stroke	182	341	364					
160	40 ^{-0.050} _{-0.089}	60	212	204	292	120	173	346	82	75	40	141	1/5 stroke	194	367	388					

ø180 to ø250

With rod boot

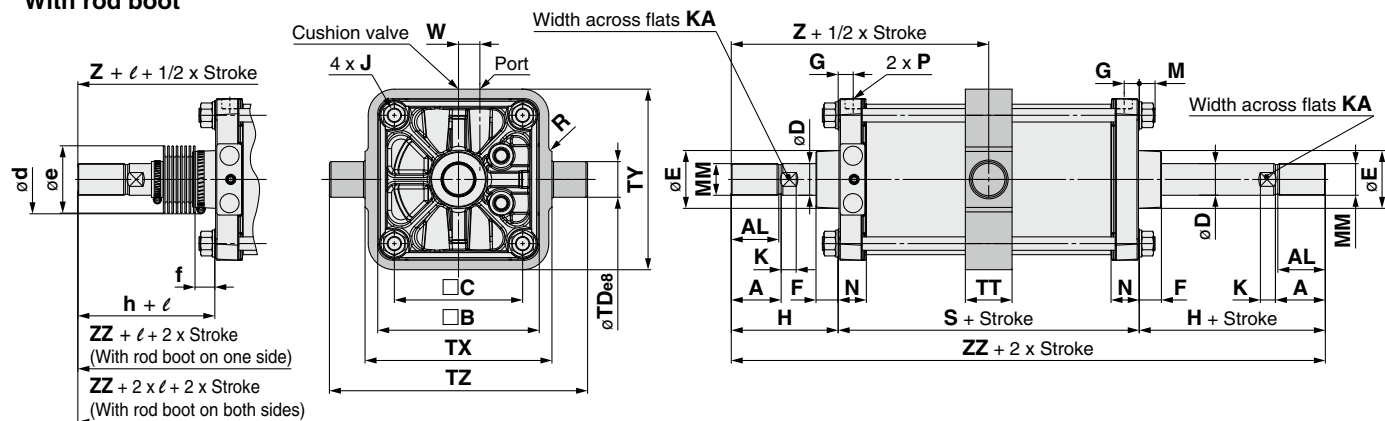

Bore size	Stroke range	A	AL	B	C	D	E	F	G	J	K	KA	M	MM	N	P	R	S	TDe8
180	25 to 1200	63	60	204	162	40	73	28	19	M18 x 1.5	17	36	20	M40 x 1.5	35.6	1/2	2	115	45 ^{-0.050} _{-0.089}
200	25 to 998	63	60	226	182	45	78.5	32	19	M20 x 1.5	20	41	21	M45 x 1.5	35.6	1/2	2	120	45 ^{-0.050} _{-0.089}
250	25 to 813	71	67	277	225	56	91	43	23	M24 x 1.5	22	50	25	M56 x 2	45.6	3/4	3	141	56 ^{-0.060} _{-0.106}

Bore size	TT	TX	TY	TZ	W	Without rod boot			With rod boot (One side)										(Both sides)		
						H	Z	ZZ	d	e	f	h	l	Z	ZZ	ZZ					
180	59	236	228	326	27	135	192.5	388	92	85	25	153	1/5 stroke	210.5	403	421					
200	59	265	257	355	27	135	195	393	96	90	29	153	1/5 stroke	213	408	426					
250	69	335	325	447	32	160	230.5	465	108	105	36	176	1/6 stroke	246.5	477	493					

Standard Double Acting, Single Rod **CS2**
 Double Acting, Double Rod **CS2W**
 Long Stroke Double Acting, Single Rod **CS2-V**
 Axial Centralized Piping Double Acting, Single Rod **CS2-P**

Auto Switch

Made to Order

CS2W Series

Dimensions

Center trunnion: CS2WT

ø320

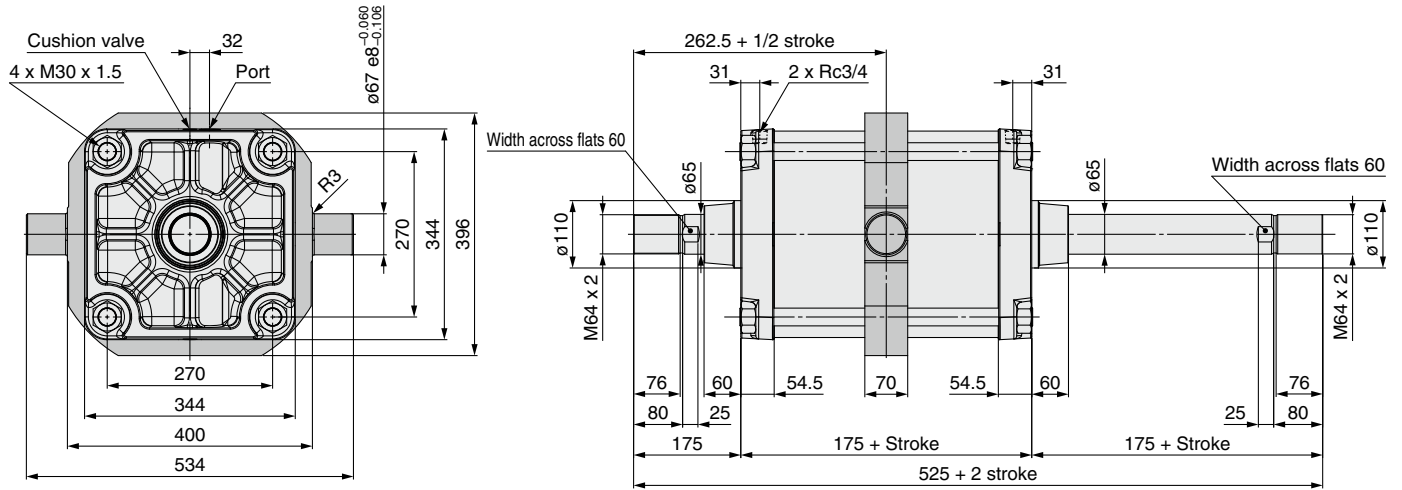

With rod boot

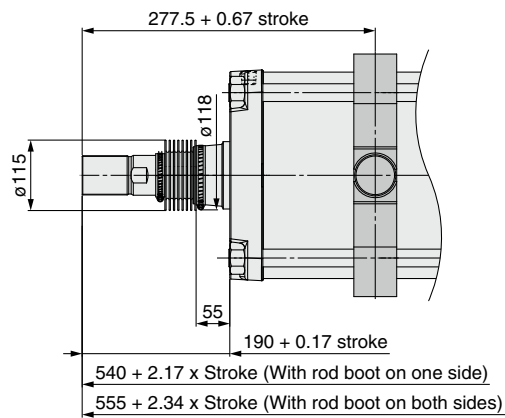

Auto Switch Proper Mounting Position (Detection at Stroke End) and Mounting Height

<Tie-rod mounting>

D-M9□/M9□V **D-Z7□/Z80**
D-M9□W/M9□WV **D-Y59□/Y69□/Y7P/Y7PV**
D-M9□A/M9□AV **D-Y7□W/Y7□WV**
D-A9□/A9□V **D-Y7BA**

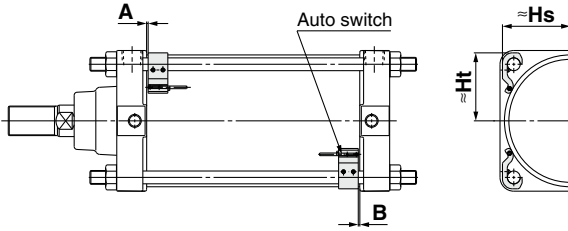

D-F5□/J59/D-F5NT **D-F5□W/J59□W**
D-F5BAL/F59F **D-A5□/A6□**

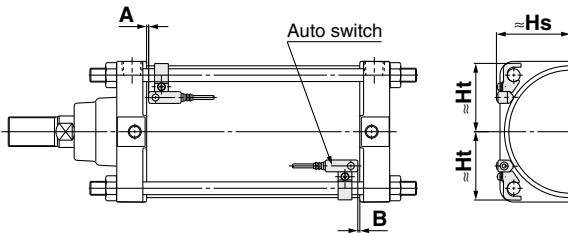

D-P3DWA

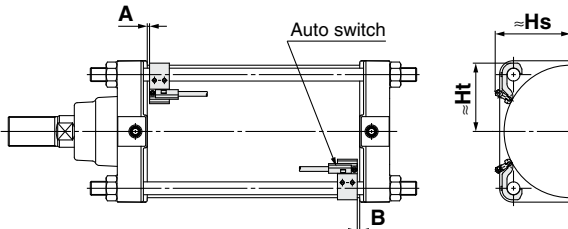

<Band mounting>

D-G3/K3
D-A3□

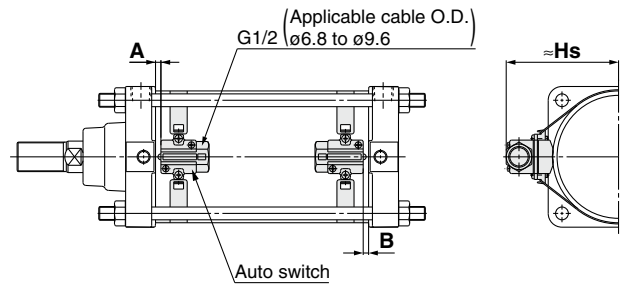

D-A44

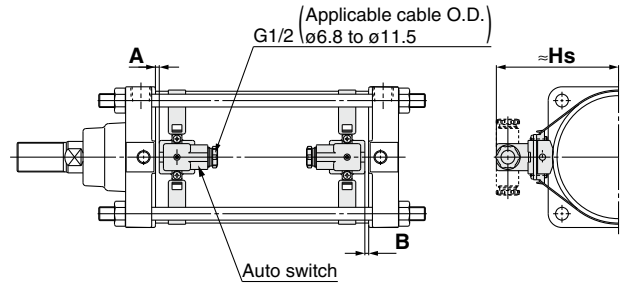

* The indicator light faces the inside.

Auto Switch Proper Mounting Position (Detection at Stroke End) and Mounting Height

Applicable Cylinder: CDS2, CDS2W (Double rod), CDS2□P (Axial centralized piping) [mm]

Auto switch model	D-M9□ D-M9□V D-M9□W D-M9□WV D-M9□A D-M9□AV		D-A9□ D-A9□V		D-Y5□/Y6□ D-Y7P/Y7PV D-Y7□W D-Y7□WV D-Y7BA D-Z7□/Z80		D-G39 D-K39 D-A3□ D-A44		D-A5□ D-A6□		D-A59W		D-F5□ D-F5□W D-J59 D-J59W D-F5BA D-F59F		D-F5NT		D-P3DWA	
	A	B	A	B	A	B	A	B	A	B	A	B	A	B	A	B	A	B
125	13	12	9	8	6.5	5.5	3	2	3	2	7	6	9.5	8.5	14.5	13.5	8.5	7.5
140	13	12	9	8	6.5	5.5	3	2	3	2	7	6	9.5	8.5	14.5	13.5	8.5	7.5
160	13	12	9	8	6.5	5.5	3	2	3	2	7	6	9.5	8.5	14.5	13.5	8.5	7.5
180	21	11	17	7	—	—	—	—	11	1	15	5	17.5	7.5	22.5	12.5	16.5	6.5
200	23.5	13.5	19.5	9.5	—	—	—	—	13.5	3.5	17.5	7.5	20	10	25	15	19	9
250	24	14	20	10	—	—	—	—	—	—	—	—	—	—	—	—	—	—
320	32	22	28	18	—	—	—	—	—	—	—	—	—	—	—	—	—	—

* Provided as guidelines for auto switch proper mounting position (detection at stroke end)
Adjust the auto switch after confirming the operating conditions in the actual setting.

Applicable Cylinder: CDS2-V (Long stroke) [mm]

Auto switch model	D-M9□ D-M9□V D-M9□W D-M9□WV D-M9□A D-M9□AV		D-A9□ D-A9□V	
	A	B	A	B
180	12.5	12.5	8.5	8.5
200	15	15	11	11
250	21.5	9.5	17.5	5.5
320	42.5	11.5	38.5	7.5

* Provided as guidelines for auto switch proper mounting position (detection at stroke end)
Adjust the auto switch after confirming the operating conditions in the actual setting.

Auto Switch Mounting Height

Applicable Cylinder: CDS2, CDS2W (Double rod), CDS2□P (Axial centralized piping) [mm]

Auto switch model	D-M9□ D-M9□W D-M9□A D-A9□		D-M9□V D-M9□WV D-M9□AV D-A9□V		D-Y5□/Y6□ D-Y7P D-Y7PV D-Y7□W D-Y7□WV D-Y7BA D-Z7□/Z80		D-G39 D-K39 D-A3□		D-A44		D-A5□ D-A6□ D-A59W		D-F5□ D-F5□W D-J59 D-J59W D-F5BA D-F59F D-F5NT		D-P3DWA	
	Hs	Ht	Hs	Ht	Hs	Ht	Hs	Hs	Hs	Ht	Hs	Ht	Hs	Ht	Hs	Ht
125	69	69.5	71.5	69.5	69	69.5	116	126	75.5	69.5	74.5	70	76	69.5	—	
140	76	76	77.5	76	76	76	124	134	81	76.5	80	76.5	82	76	—	
160	85	85	86	85	85	85	134.5	144.5	89	87.5	88	87.5	91	85	—	
180	95	95	95.5	95	—	—	—	—	97	97.5	96	97.5	100	95	—	
200	106	106	106	106	—	—	—	—	107	108	107	108	111	106	—	
250	130.5	131.5	130.5	131.5	—	—	—	—	—	—	—	—	—	—	—	
320	160	156.5	160	156.5	—	—	—	—	—	—	—	—	—	—	—	

Applicable Cylinder: CDS2-V (Long stroke) [mm]

Auto switch model	D-M9□ D-M9□W D-M9□A D-A9□		D-M9□V D-M9□WV D-M9□AV D-A9□V	
	Hs	Ht	Hs	Ht
180	95	95	95.5	95
200	106	106	106	106
250	130.5	131.5	130.5	131.5
320	160	156.5	160	156.5

Standard Double Acting, Single Rod **CS2**
 Double Acting, Double Rod **CS2W**
 Long Stroke Double Acting, Single Rod **CS2-V**
 Axial Centralized Piping Double Acting, Single Rod **CS2□P**
 Auto Switch
 Made to Order

Minimum Stroke for Auto Switch Mounting

Applicable Cylinder: CDS2, CDS2W (Double rod), CDS2□P (Axial centralized piping) n: Number of auto switches [mm]

Auto switch model	Number of auto switches	Brackets other than center trunnion	Center trunnion						
			125	140	160	180	200	250	320
D-M9□ D-M9□W	2 (Different surfaces, same surface), 1	15	105	110	115	115	125	135	
	n	$15 + 40 \frac{(n-2)}{2}$ (n = 2, 4, 6, 8...)*1	$105 + 40 \frac{(n-4)}{2}$ (n = 4, 8, 12, 16...)*2	$110 + 40 \frac{(n-4)}{2}$ (n = 4, 8, 12, 16...)*2	$115 + 40 \frac{(n-4)}{2}$ (n = 4, 8, 12, 16...)*2	$115 + 40 \frac{(n-4)}{2}$ (n = 4, 8, 12, 16...)*2	$125 + 40 \frac{(n-4)}{2}$ (n = 4, 8, 12, 16...)*2	$135 + 40 \frac{(n-4)}{2}$ (n = 4, 8, 12, 16...)*2	
D-M9□V D-M9□WV	2 (Different surfaces, same surface), 1	10	80	85	90	100	110	110	
	n	$10 + 30 \frac{(n-2)}{2}$ (n = 2, 4, 6, 8...)*1	$80 + 30 \frac{(n-4)}{2}$ (n = 4, 8, 12, 16...)*2	$85 + 30 \frac{(n-4)}{2}$ (n = 4, 8, 12, 16...)*2	$90 + 30 \frac{(n-4)}{2}$ (n = 4, 8, 12, 16...)*2	$100 + 30 \frac{(n-4)}{2}$ (n = 4, 8, 12, 16...)*2	$100 + 30 \frac{(n-4)}{2}$ (n = 4, 8, 12, 16...)*2	$110 + 30 \frac{(n-4)}{2}$ (n = 4, 8, 12, 16...)*2	
D-M9□A	2 (Different surfaces, same surface), 1	20	115	120	120	130	140		
	n	$20 + 40 \frac{(n-2)}{2}$ (n = 2, 4, 6, 8...)*1	$115 + 40 \frac{(n-4)}{2}$ (n = 4, 8, 12, 16...)*2	$120 + 40 \frac{(n-4)}{2}$ (n = 4, 8, 12, 16...)*2	$120 + 40 \frac{(n-4)}{2}$ (n = 4, 8, 12, 16...)*2	$130 + 40 \frac{(n-4)}{2}$ (n = 4, 8, 12, 16...)*2	$140 + 40 \frac{(n-4)}{2}$ (n = 4, 8, 12, 16...)*2		
D-M9□AV	2 (Different surfaces, same surface), 1	15	90	95	105	115	115		
	n	$15 + 30 \frac{(n-2)}{2}$ (n = 2, 4, 6, 8...)*1	$90 + 30 \frac{(n-4)}{2}$ (n = 4, 8, 12, 16...)*2	$95 + 30 \frac{(n-4)}{2}$ (n = 4, 8, 12, 16...)*2	$105 + 30 \frac{(n-4)}{2}$ (n = 4, 8, 12, 16...)*2	$115 + 30 \frac{(n-4)}{2}$ (n = 4, 8, 12, 16...)*2	$115 + 30 \frac{(n-4)}{2}$ (n = 4, 8, 12, 16...)*2		
D-A9□	2 (Different surfaces, same surface), 1	15	100	105	110	110	120	130	
	n	$15 + 40 \frac{(n-2)}{2}$ (n = 2, 4, 6, 8...)*1	$100 + 40 \frac{(n-4)}{2}$ (n = 4, 8, 12, 16...)*2	$105 + 40 \frac{(n-4)}{2}$ (n = 4, 8, 12, 16...)*2	$110 + 40 \frac{(n-4)}{2}$ (n = 4, 8, 12, 16...)*2	$110 + 40 \frac{(n-4)}{2}$ (n = 4, 8, 12, 16...)*2	$120 + 40 \frac{(n-4)}{2}$ (n = 4, 8, 12, 16...)*2	$130 + 40 \frac{(n-4)}{2}$ (n = 4, 8, 12, 16...)*2	
D-A9□V	2 (Different surfaces, same surface), 1	10	75	80	85	95	105	105	
	n	$10 + 30 \frac{(n-2)}{2}$ (n = 2, 4, 6, 8...)*1	$75 + 30 \frac{(n-4)}{2}$ (n = 4, 8, 12, 16...)*2	$80 + 30 \frac{(n-4)}{2}$ (n = 4, 8, 12, 16...)*2	$85 + 30 \frac{(n-4)}{2}$ (n = 4, 8, 12, 16...)*2	$95 + 30 \frac{(n-4)}{2}$ (n = 4, 8, 12, 16...)*2	$105 + 30 \frac{(n-4)}{2}$ (n = 4, 8, 12, 16...)*2	$105 + 30 \frac{(n-4)}{2}$ (n = 4, 8, 12, 16...)*2	
D-F5□/J59 D-F5□W D-J59W D-F5BA D-F59F D-A5□/A6□ D-A59W	2 (Different surfaces, same surface), 1	25	125	135	150	—	—		
	n (Same surface)	$25 + 55 \frac{(n-2)}{2}$ (n = 2, 4, 6, 8...)*1	$125 + 55 \frac{(n-4)}{2}$ (n = 4, 8, 12, 16...)*2	$135 + 55 \frac{(n-4)}{2}$ (n = 4, 8, 12, 16...)*2	$150 + 55 \frac{(n-4)}{2}$ (n = 4, 8, 12, 16...)*2	—	—		
D-F5NT	2 (Different surfaces, same surface), 1	35	145	155	165	—	—		
	n (Same surface)	$35 + 55 \frac{(n-2)}{2}$ (n = 2, 4, 6, 8...)*1	$145 + 55 \frac{(n-4)}{2}$ (n = 4, 8, 12, 16...)*2	$155 + 55 \frac{(n-4)}{2}$ (n = 4, 8, 12, 16...)*2	$165 + 55 \frac{(n-4)}{2}$ (n = 4, 8, 12, 16...)*2	—	—		
D-G39 D-K39 D-A3□	2 Different surfaces	35	110				—	—	
	2 Same surface	100	110						
	n	Different surfaces	$35 + 30(n-2)$ (n = 2, 3, 4, 5...)	$110 + 30(n-2)$ (n = 2, 4, 6, 8...)*1					
		Same surface	$100 + 100(n-2)$ (n = 2, 3, 4, 5...)	$110 + 100(n-2)$ (n = 2, 4, 6, 8...)*1					
1	15	110							
D-A44	2 Different surfaces	35	110				—	—	
	2 Same surface	55	110						
	n	Different surfaces	$35 + 30(n-2)$ (n = 2, 3, 4, 5...)	$110 + 30(n-2)$ (n = 2, 4, 6, 8...)*1					
		Same surface	$55 + 55(n-2)$ (n = 2, 3, 4, 5...)	$110 + 50(n-2)$ (n = 2, 4, 6, 8...)*1					
1	15	110							
D-Y59□ D-Y7P D-Y7□W D-Z7□ D-Z80	2 (Different surfaces, same surface), 1	15	105	110	115	—	—		
	n	$15 + 40 \frac{(n-2)}{2}$ (n = 2, 4, 6, 8...)*1	$105 + 40 \frac{(n-4)}{2}$ (n = 4, 8, 12, 16...)*2	$110 + 40 \frac{(n-4)}{2}$ (n = 4, 8, 12, 16...)*2	$115 + 40 \frac{(n-4)}{2}$ (n = 4, 8, 12, 16...)*2	—	—		
D-Y69□ D-Y7PV D-Y7□WV	2 (Different surfaces, same surface), 1	10	90	95	100	—	—		
	n	$10 + 30 \frac{(n-2)}{2}$ (n = 2, 4, 6, 8...)*1	$90 + 30 \frac{(n-4)}{2}$ (n = 4, 8, 12, 16...)*2	$95 + 30 \frac{(n-4)}{2}$ (n = 4, 8, 12, 16...)*2	$100 + 30 \frac{(n-4)}{2}$ (n = 4, 8, 12, 16...)*2	—	—		
D-Y7BA	2 (Different surfaces, same surface), 1	20	115	120	125	—	—		
	n	$20 + 45 \frac{(n-2)}{2}$ (n = 2, 4, 6, 8...)*1	$115 + 45 \frac{(n-4)}{2}$ (n = 4, 8, 12, 16...)*2	$120 + 45 \frac{(n-4)}{2}$ (n = 4, 8, 12, 16...)*2	$125 + 45 \frac{(n-4)}{2}$ (n = 4, 8, 12, 16...)*2	—	—		
D-P3DWA	2 (Different surfaces, same surface), 1	20	105	110	115	125	—		
	n	$20 + 50 \frac{(n-2)}{2}$ (n = 2, 4, 6, 8...)*1	$105 + 50 \frac{(n-4)}{2}$ (n = 4, 8, 12, 16...)*2	$110 + 50 \frac{(n-4)}{2}$ (n = 4, 8, 12, 16...)*2	$115 + 50 \frac{(n-4)}{2}$ (n = 4, 8, 12, 16...)*2	$125 + 50 \frac{(n-4)}{2}$ (n = 4, 8, 12, 16...)*2	—		

*1 When "n" is an odd number, an even number that is one larger than the odd number is to be used for the calculation.

*2 When "n" is an odd number, a multiple of 4 that is larger than the odd number is to be used for the calculation.

Minimum Stroke for Auto Switch Mounting

Applicable Cylinder: CDS2-V (Long stroke)

n: Number of auto switches [mm]

Auto switch model	Number of auto switches	Brackets other than center trunnion	Center trunnion			
			180	200	250	320
D-M9□ D-M9□W	2 (Different surfaces, same surface), 1	15	115		135	155
	n	$15 + 40 \frac{(n-2)}{2}$ (n = 2, 4, 6, 8...)*1	$115 + 40 \frac{(n-4)}{2}$ (n = 4, 8, 12, 16...)*2		$135 + 40 \frac{(n-4)}{2}$ (n = 4, 8, 12, 16...)*2	$155 + 40 \frac{(n-4)}{2}$ (n = 4, 8, 12, 16...)*2
D-M9□V D-M9□WV	2 (Different surfaces, same surface), 1	10	90		110	130
	n	$10 + 30 \frac{(n-2)}{2}$ (n = 2, 4, 6, 8...)*1	$90 + 30 \frac{(n-4)}{2}$ (n = 4, 8, 12, 16...)*2		$110 + 30 \frac{(n-4)}{2}$ (n = 4, 8, 12, 16...)*2	$130 + 30 \frac{(n-4)}{2}$ (n = 4, 8, 12, 16...)*2
D-M9□A	2 (Different surfaces, same surface), 1	20	115		140	160
	n	$20 + 40 \frac{(n-2)}{2}$ (n = 2, 4, 6, 8...)*1	$115 + 40 \frac{(n-4)}{2}$ (n = 4, 8, 12, 16...)*2		$140 + 40 \frac{(n-4)}{2}$ (n = 4, 8, 12, 16...)*2	$160 + 40 \frac{(n-4)}{2}$ (n = 4, 8, 12, 16...)*2
D-M9□AV	2 (Different surfaces, same surface), 1	15	95		115	135
	n	$15 + 30 \frac{(n-2)}{2}$ (n = 2, 4, 6, 8...)*1	$95 + 30 \frac{(n-4)}{2}$ (n = 4, 8, 12, 16...)*2		$115 + 30 \frac{(n-4)}{2}$ (n = 4, 8, 12, 16...)*2	$135 + 30 \frac{(n-4)}{2}$ (n = 4, 8, 12, 16...)*2
D-A9□	2 (Different surfaces, same surface), 1	15	110		130	150
	n	$15 + 40 \frac{(n-2)}{2}$ (n = 2, 4, 6, 8...)*1	$110 + 40 \frac{(n-4)}{2}$ (n = 4, 8, 12, 16...)*2		$130 + 40 \frac{(n-4)}{2}$ (n = 4, 8, 12, 16...)*2	$150 + 40 \frac{(n-4)}{2}$ (n = 4, 8, 12, 16...)*2
D-A9□V	2 (Different surfaces, same surface), 1	10	85		105	125
	n	$10 + 30 \frac{(n-2)}{2}$ (n = 2, 4, 6, 8...)*1	$85 + 30 \frac{(n-4)}{2}$ (n = 4, 8, 12, 16...)*2		$105 + 30 \frac{(n-4)}{2}$ (n = 4, 8, 12, 16...)*2	$125 + 30 \frac{(n-4)}{2}$ (n = 4, 8, 12, 16...)*2

*1 When "n" is an odd number, an even number that is one larger than the odd number is to be used for the calculation.

*2 When "n" is an odd number, a multiple of 4 that is larger than the odd number is to be used for the calculation.

Operating Range

Applicable Cylinder: CDS2, CDS2W (Double rod), CDS2□P (Axial centralized piping) [mm]

Auto switch model	Bore size						
	125	140	160	180	200	250	320
D-M9□/M9□V D-M9□W/M9□WV D-M9□A/M9□AV	6	6.5	6.5	7.5	8.5	9	9
D-A9□/A9□V	12	12.5	11.5	11	16.5	15	13
D-Z7□/Z80	14	14.5	13	—	—	—	—
D-A3□/A44	10	10	10	—	—	—	—
D-A5□/A6□	10	10	10	13	16.5	—	—
D-A59W	17	17	17	17	22	—	—
D-Y59□/Y69□ D-Y7P/Y7PV D-Y7□W/Y7□WV D-Y7BA	12	13	7	—	—	—	—
D-F5□/J59/F5□W D-J59W/F5BA D-F5NT/F59F	5	5	5.5	5.5	6	—	—
D-G39/K39	11	11	10	—	—	—	—
D-P3DWA	7	7	7	7.5	8.5	—	—

* Values which include hysteresis are for reference purposes only. They are not a guarantee (assuming approximately ±30% dispersion) and may change substantially depending on the ambient environment.

Applicable Cylinder: CDS2-V (Long stroke) [mm]

Auto switch model	Bore size			
	180	200	250	320
D-M9□/M9□V D-M9□W/M9□WV D-M9□A/M9□AV	7.5	8.5	9	9
D-A9□/A9□V	11	16.5	15	13
D-Z7□/Z80	—	—	—	—
D-A3□/A44	—	—	—	—
D-A5□/A6□	—	—	—	—
D-A59W	—	—	—	—
D-Y59□/Y69□ D-Y7P/Y7PV D-Y7□W/Y7□WV D-Y7BA	—	—	—	—
D-F5□/J59/F5□W D-J59W/F5BA D-F5NT/F59F	—	—	—	—
D-G39/K39	—	—	—	—
D-P3DWA	—	—	—	—

Standard Double Acting, Single Rod **CS2**
 Double Acting, Double Rod **CS2W**
 Long Stroke Double Acting, Single Rod **CS2-V**
 Axial Centralized Piping Double Acting, Single Rod **CS2□P**

Auto Switch
 Made to Order

Auto Switch Mounting Brackets/Part Nos.

Auto switch model	Bore size [mm]						
	125	140	160	180	200	250	320
D-M9□/M9□V D-M9□W/M9□WV D-M9□A/M9□AV D-A9□/A9□V	BS5-125	BS5-125	BS5-160	BS5-180	BS5-200	BS5-250	BS5-320
D-F5□/J59 D-F5NT D-F5□W/J59W D-F5BAL/F59F D-A5□/A6□ D-A59W	BT-12	BT-12	BT-16	BT-18A	BT-20	—	—
D-G39/K39 D-A3□/A44	BS1-125	BS1-140	BS1-160	—	—	—	—
D-Y59□/Y69□ D-Y7P/Y7PV D-Y7□W/Y7□WV D-Y7BA D-Z7□/Z80	BS4-125	BS4-125	BS4-160	—	—	—	—
D-P3DWA	BS7-125S	BS7-125S	BS7-160S	BS7-180S	BS7-200S	—	—

[Stainless Steel Mounting Screw]

The following stainless steel mounting screw kit (including set screws) is available. Use it in accordance with the operating environment. (Since the auto switch mounting bracket is not included, order it separately.)

BBA1: For D-A5/A6/F5/J5 types

The above stainless steel screws are used when a cylinder is shipped with the D-F5BA auto switch. When only one auto switch is shipped independently, the BBA1 is attached.

* When using the D-M9□A/M9□AV or Y7BA, do not use the steel set screws which are included with the auto switch mounting brackets on the left (BS5-□□□, BS4-□□□).

Order a stainless steel screw kit (BBA1) separately, and use the M4 x 8 L stainless steel set screws included in the BBA1.

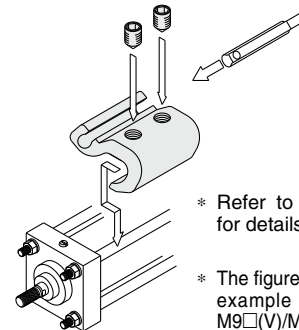

* Refer to the **Web Catalog** for details on the BBA1.

* The figure shows the mounting example for the D-A9□(V)/M9□(V)/M9□W(V)/M9□A(V)

Other than the applicable auto switches listed in “How to Order,” the following auto switches are also mountable. Refer to the **Web Catalog** for the detailed specifications.

Type	Model	Electrical entry	Features
Solid state	D-F59, F5P, J59	Grommet (In-line)	—
	D-Y59A, Y59B, Y7P		2-color indicator
	D-F59W, F5PW, J59W		Water-resistant (2-color indicator)
	D-Y7NW, Y7PW, Y7BW		With timer
	D-F5BA, Y7BA		—
	D-F5NT		—
Reed	D-M9NV, M9PV, M9BV	Grommet (Perpendicular)	—
	D-Y69A, Y69B, Y7PV		2-color indicator
	D-M9NWV, M9PWV, M9BWV		Water-resistant (2-color indicator)
	D-Y7NWV, Y7PWV, Y7BWV		Without indicator light
	D-M9NAV, M9PAV, M9BAV		—
	D-A90V		Grommet (In-line)
D-A93V, A96V	Without indicator light		
D-Z73, Z76	—		
D-A53, A56	—		
D-A67	Without indicator light		
D-Z80	—		

* With pre-wired connector is also available for solid state switches. For details, refer to the **Web Catalog**.

* Normally closed (NC = b contact) solid state auto switches (D-M9□E(V)/D-Y7G/Y7H) are also available. For details, refer to the **Web Catalog**.

Prior to Use

Auto Switch Connections and Examples

Sink Input Specifications

3-wire, NPN

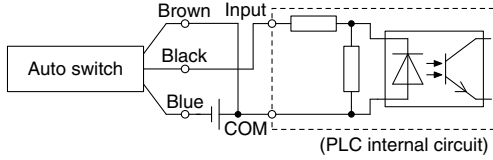

2-wire

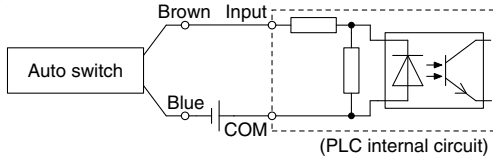

Source Input Specifications

3-wire, PNP

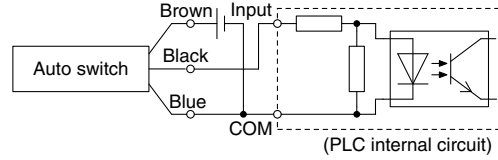

2-wire

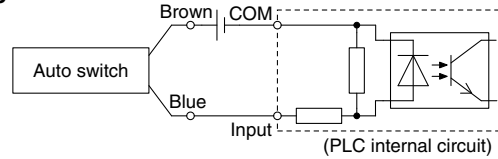

Connect according to the applicable PLC input specifications, as the connection method will vary depending on the PLC input specifications.

Examples of AND (Series) and OR (Parallel) Connections

* When using solid state auto switches, ensure the application is set up so the signals for the first 50 ms are invalid. Depending on the operating environment, the product may not operate properly.

3-wire AND connection for NPN output (Using relays)

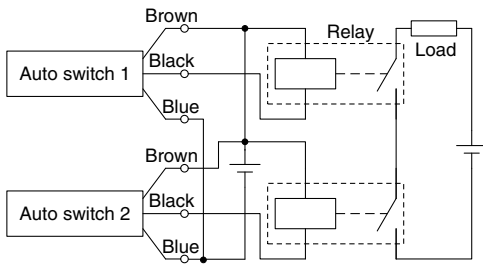

(Performed with auto switches only)

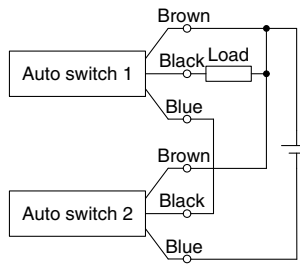

3-wire OR connection for NPN output

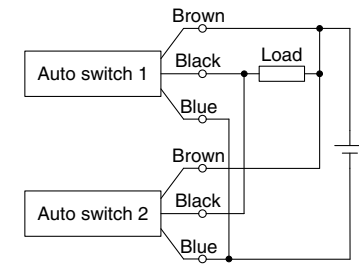

3-wire AND connection for PNP output (Using relays)

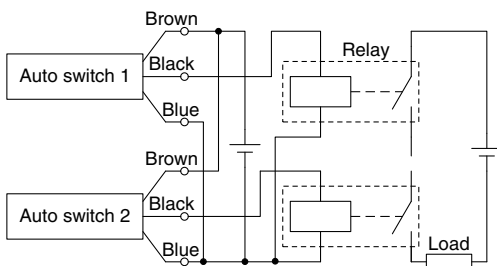

(Performed with auto switches only)

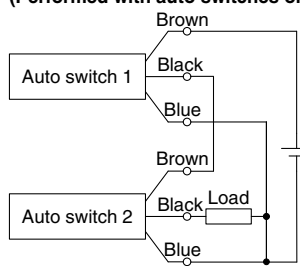

3-wire OR connection for PNP output

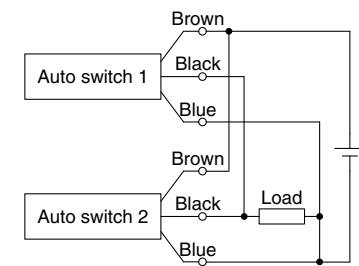

2-wire AND connection

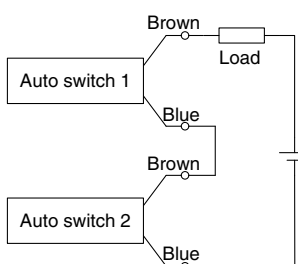

When two auto switches are connected in series, a load may malfunction because the load voltage will decline when in the ON state. The indicator lights will light up when both of the auto switches are in the ON state. Auto switches with a load voltage less than 20 V cannot be used. Please contact SMC if using AND connection for a heat-resistant solid state auto switch or a trimmer switch.

Example) Load voltage at ON
 Power supply voltage: 24 VDC
 Internal voltage drop: 4 V
 Load voltage at ON = Power supply voltage – Internal voltage drop x 2 pcs.
 = 24 V – 4 V x 2 pcs.
 = 16 V

2-wire OR connection

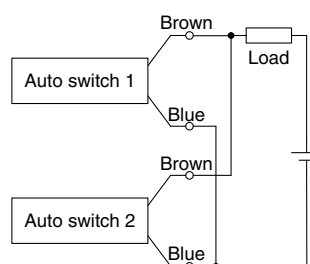

(Solid state)
 When two auto switches are connected in parallel, malfunction may occur because the load voltage will increase when in the OFF state.

(Reed)
 Because there is no current leakage, the load voltage will not increase when turned OFF. However, depending on the number of auto switches in the ON state, the indicator lights may sometimes grow dim or not light up, due to the dispersion and reduction of the current flowing to the auto switches.

Example) Load voltage at OFF
 Leakage current: 1 mA
 Load impedance: 3 kΩ
 Load voltage at OFF = Leakage current x 2 pcs. x Load impedance
 = 1 mA x 2 pcs. x 3 kΩ
 = 6 V

Standard Double Acting, Single Rod CS2
 Double Acting, Double Rod CS2W
 Long Stroke Double Acting, Single Rod CS2-V
 Axial Centralized Piping Double Acting, Single Rod CS2-IP
 Auto Switch
 Made to Order

Simple Specials/Made to Order Common Specifications

Please contact SMC for detailed specifications, delivery, and prices.

Simple Specials

The following special specifications can be ordered as a simplified Made-to-Order. Please contact your local sales representative for more details.

Symbol	Specifications	CS2 (Standard type)				CS2-V (Long stroke type)	CS2□P (Axial centralized piping type)	Page			
		Double acting									
		Single rod		Double rod		Single rod					
		Non-lube									
ø125 to ø160		ø180 to ø320		ø125 to ø160		ø180 to ø320		ø180 to ø320		ø180 to ø250	
-XA□	Change of rod end shape	●	●	●	●	●	●	66			
-XC14	Change of trunnion bracket mounting position	●	●	●	●	●	●	67			
-XC15	Change of tie-rod length	●	●	●	●	●	●	67			

Made to Order Common Specifications

Symbol	Specifications	CS2 (Standard type)				CS2-V (Long stroke type)	CS2□P (Axial centralized piping type)	Page			
		Double acting									
		Single rod		Double rod		Single rod					
		Non-lube									
ø125 to ø160		ø180 to ø320		ø125 to ø160		ø180 to ø320		ø180 to ø320		ø180 to ø250	
-XB6	Heat-resistant cylinder (0 to 150°C)	●		●				68			
-XC3	Special port location	●						68			
-XC4	With heavy duty scraper	●		●				69			
-XC5	Heat-resistant cylinder (0 to 110°C)	●		●				69			
-XC9	Adjustable stroke cylinder/Adjustable retraction type	●						70			
-XC10	Dual stroke cylinder/Double rod type	●						71			
-XC11	Dual stroke cylinder/Single rod type	●						72			
-XC22	Fluororubber seal	●		●				73			
-XC26	With split pins for double clevis pin/double knuckle joint pin and flat washers	●	●					73			
-XC27	Double clevis and double knuckle joint pins made of stainless steel	●	●					74			
-XC30	Rod side trunnion	●		●				74			
-XC35	With coil scraper	●		●				75			
-XC68	Made of stainless steel (With hard chrome plated piston rod)	●	●	●	●			75			
-XC86	With rod end bracket	●	●					75			

Air Cylinder/CS2 Series Simple Specials

The following changes are dealt with through the Simple Specials System.

To place an order, please download the Simple Special Order Specification Form from the SMC website.



Symbol

-XA0 to XA30

1 Change of Rod End Shape

Applicable Series

Description	Model	Action	Symbol for change of rod end shape	Note
Standard type	CS2	Double acting, Single rod	XA0 to 30	
	CS2W	Double acting, Double rod	XA0 to 30	
Long stroke type	CS2-V	Double acting, Single rod	XA0 to 30	ø180 to ø320
Axial centralized piping type	CS2□P	Double acting, Single rod	XA0 to 30	ø180 to ø250

Precautions

- SMC will make appropriate arrangements if no dimension, tolerance, or finish instructions are given in the diagram.
- Standard dimensions marked with "*" will be as follows to the rod diameter (D). Enter any special dimension you require.
 $D \leq 6 \rightarrow D - 1 \text{ mm}$, $6 < D \leq 25 \rightarrow D - 2 \text{ mm}$, $D > 25 \rightarrow D - 4 \text{ mm}$
- In the case of the double rod type and single acting retraction type, enter the dimensions when the rod is retracted.
- Only one side of a double rod can be manufactured.
- "A0" is the same shape as the standard type. (The specifications of A0 are that only dimensions A and H are changed from the standard type.)

Symbol: A0 	Symbol: A1 	Symbol: A2 	Symbol: A3 	Symbol: A4
Symbol: A5 	Symbol: A6 	Symbol: A7 	Symbol: A8 	Symbol: A9
Symbol: A10 	Symbol: A11 	Symbol: A12 	Symbol: A13 	Symbol: A14
Symbol: A15 	Symbol: A16 	Symbol: A17 	Symbol: A18 	Symbol: A19
Symbol: A20 	Symbol: A21 	Symbol: A22 	Symbol: A23 	Symbol: A24
Symbol: A25 	Symbol: A26 	Symbol: A27 	Symbol: A28 	Symbol: A29
Symbol: A30 				

Standard
Double Acting, Single Rod
CS2

Double Acting, Double Rod
CS2W

Long Stroke
Double Acting, Single Rod
CS2-V

Axial Centralized Piping
Double Acting, Single Rod
CS2□P

Auto Switch

Made to Order

2 Change of Trunnion Bracket Mounting Position

Symbol
-XC14

The position for mounting the trunnion pivot bracket on the cylinder can be moved from the standard mounting position to any desired position.

Applicable Series

Description	Model	Action	Note
Standard type	CS2	Double acting, Single rod	
	CS2W	Double acting, Double rod	
Long stroke type	CS2-V	Double acting, Single rod	ø180 to ø320
Axial centralized piping type	CS2□P	Double acting, Single rod	ø180 to ø250

Precautions

- Specify "Z + 1/2 x Stroke" in the case the trunnion bracket position is not -XC14A, -XC14B or trunnion is not a center trunnion.
- SMC will make appropriate arrangements if no dimension, tolerance, or finish instructions are given in the diagram.
- The possible range of trunnion bracket mounting position is indicated in the table below.
- Some trunnion mounting positions do not allow auto switch mounting. Please consult with SMC for more information.
- The CS2 series has a greater range of trunnion bracket mounting positions than CS1 series, so the value of "Z + 1/2 x Stroke" at -XC14A and -XC14B is different.

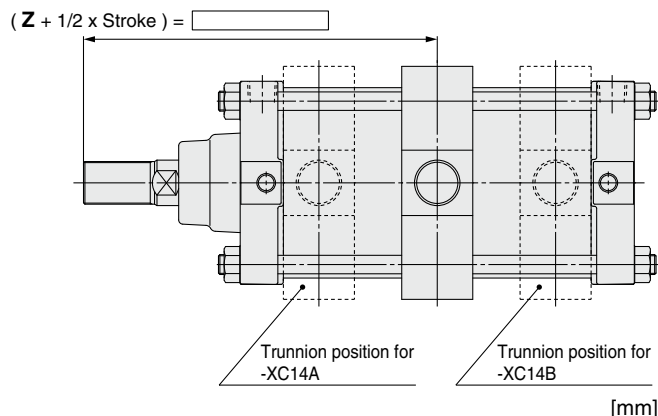

[mm]

Bore size	Symbol	Z + 1/2 x Stroke					
		For -XC14A	For -XC14B	For -XC14		Reference Standard (Center trunnion)	Minimum stroke
				Minimum	Maximum		
125		165.5	152.5 + Stroke	166	152 + Stroke	159 + 1/2 x Stroke	25
140		168	150 + Stroke	168.5	149.5 + Stroke	159 + 1/2 x Stroke	30
160		186	160 + Stroke	186.5	159.5 + Stroke	173 + 1/2 x Stroke	35
180		200	185 + Stroke	200.5	184.5 + Stroke	192.5 + 1/2 x Stroke	25
200		200	190 + Stroke	200.5	189.5 + Stroke	195 + 1/2 x Stroke	25
250		240	221 + Stroke	240.5	220.5 + Stroke	230.5 + 1/2 x Stroke	25
320		264.5	260.5 + Stroke	265	260 + Stroke	262.5 + 1/2 x Stroke	35

3 Change of Tie-rod Length

Symbol
-XC15

Cylinder with M dimension for tie-rod length changed from the standard length

Applicable Series

Description	Model	Action	Note
Standard type	CS2	Double acting, Single rod	
	CS2W	Double acting, Double rod	
Long stroke type	CS2-V	Double acting, Single rod	ø180 to ø320
Axial centralized piping type	CS2□P	Double acting, Single rod	ø180 to ø250

Precautions

- To order, specify the M dimension as well as the part number.
- SMC will make appropriate arrangements if no dimension, tolerance, or finish instructions are given in the diagram.
- Tie-rod length changeable range is described in the below.
- The M dimension of the bracket mounting side of flange (F, G), clevis (C, D) types cannot be specified.

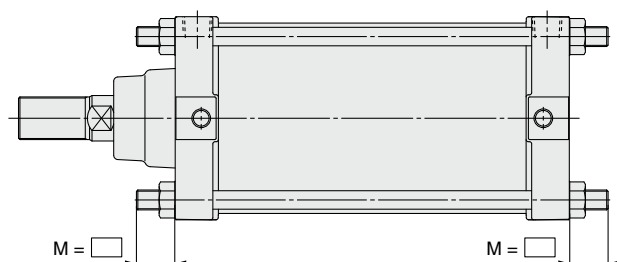

Tie-rod Length Changeable Range

[mm]

Bore size	125		140		160		180		200		250		320	
Mounting bracket	L	B, F, G, C, D, T	L	B, F, G, C, D, T	L	B, F, G, C, D, T	L	B, F, G, C, D, T	L	B, F, G, C, D, T	L	B, F, G, C, D, T	L	B, F, G, C, D, T
M Min.	20	12	21	12	23	14	27	17	28	18	33	21	38	0
M Max.	110													

Made to Order Common Specifications

Please contact SMC for detailed dimensions, specifications, and delivery times.

1 Heat-resistant Cylinder (0 to 150°C)

Symbol
-XB6

The seal material and grease used in this air cylinder have been changed so that it can be used at temperatures up to 150°C.

Applicable Series

Description	Model	Action	Note
Air cylinder	CS2	Double acting, Single rod	φ125 to φ160 only Excludes the cylinder with auto switch
	CS2W	Double acting, Double rod	φ125 to φ160 only Excludes the cylinder with auto switch

Specifications

Ambient temperature range	0°C to 150°C
Seal material	Fluororubber
Grease	Heat-resistant grease
Specifications other than the above and external dimensions	Same as the standard type

How to Order

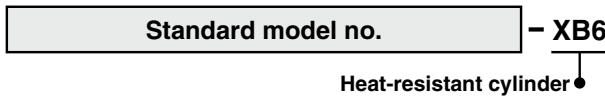

Warning Precautions

Be aware that smoking cigarettes, etc., after your hands have come into contact with the grease used in this cylinder can create a gas that is hazardous to humans.

- * Operate without lubrication from a pneumatic system lubricator.
- * Please contact SMC for details on the maintenance intervals for this cylinder as they differ from those of the standard cylinder.
- * In principle, it is impossible to make a heat-resistant cylinder with a built-in magnet or with an auto switch.
- * Piston speed ranges from 50 to 500 mm/s

2 Special Port Location

Symbol
-XC3

The locations of the connection port of the rod/head cover and the cushion valve for this cylinder are different than those of the standard type.

Applicable Series

Description	Model	Action	Note
Standard type	CS2	Double acting, Single rod	φ125 to φ160 only

How to Order

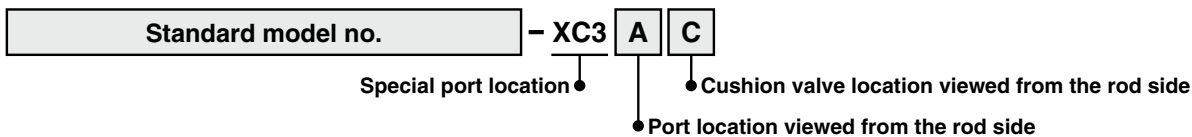

* For port locations, refer to the following diagrams and select either A, B, C, or D.

Specifications: Same as the standard type

Relationship between Port Location and Cushion Valve Location

Corresponding symbol of mounting bracket (Positional relationships)

1. The position symbols for the port and cushion valve have to be looked at from the rod side, as in the figures above. (In the case of standard cylinders, the port must be positioned on the upper side.) Define the upper side to be A, with B, C, and then D following in clockwise order.

2. -XC3AA is not available in terms of the position between the port and cushion valve, since it is available in the standard products.

Standard Double Acting, Single Rod CS2
Double Acting, Double Rod CS2W
Long Stroke Double Acting, Single Rod CS2-V
Axial Centralized Piping Double Acting, Single Rod CS2□P
Auto Switch
Made to Order

3 With Heavy Duty Scraper

Symbol
-XC4

With the heavy duty scraper on the wiper ring, this cylinder is suitable for use in environments where die-cast equipment, construction machinery or industrial vehicles are exposed to dirt or sand, or in environments with significant amounts of dust.

Applicable Series

Description	Model	Action	Note
Air cylinder	CS2	Double acting, Single rod	ø125 to ø160 only
	CS2W	Double acting, Double rod	ø125 to ø160 only

How to Order

Standard model no. **-XC4**
With heavy duty scraper

Specifications: Same as the standard type

Construction (Dimensions are the same as the standard type.)

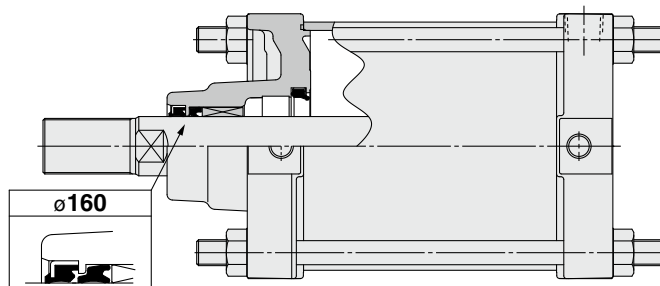

Caution

Do not replace heavy duty scrapers.

- Since heavy duty scrapers are press-fit, do not replace the cover only, but rather the entire rod cover assembly.

4 Heat-resistant Cylinder (0 to 110°C)

Symbol
-XC5

The seal material used in this air cylinder has been updated for heat resistance (up to 110°C) for use under severe ambient temperatures which exceed the standard specifications of 0 to 70°C.

Applicable Series

Description	Model	Action	Note
Air cylinder	CS2	Double acting, Single rod	ø125 to ø160 only
	CS2W	Double acting, Double rod	ø125 to ø160 only

How to Order

Standard model no. **-XC5**
Heat-resistant cylinder

Specifications

Ambient temperature range	0°C to 110°C
Seal material	Fluororubber
With auto switch	Unavailable*1
Specifications other than the above and external dimensions	Same as the standard type

*1 Manufacturing built-in magnet type and the one with auto switch is impossible.

* Please contact SMC for details on the maintenance intervals for this cylinder as they differ from those of the standard cylinder.

* Material of rod boot is heat-resistant tarpaulin.

5 Adjustable Stroke Cylinder/Adjustable Retraction Type

Symbol
-XC9

The retract stroke of the cylinder can be adjusted by the adjustment bolt.

Applicable Series

Description	Model	Action	Note
Air cylinder	CS2	Double acting, Single rod	ø125 to ø160 only (Excludes the head flange and clevis types)

How to Order

CS2 **Mounting type** **Bore size** **Port suffix** - **Stroke** **Suffix** **Stroke adjustment symbol** - **XC9**

* Excludes the head flange and clevis types

Adjustable stroke cylinder/
Adjustable retraction type

(After adjusting the stroke, the both-side cushion type becomes a single-side cushion type.)

Specifications

Series	Stroke adjustment symbol	Stroke adjustment range [mm]
CS2	A	0 to 25
	B	0 to 50

* Specifications other than the above are the same as the standard type.

Symbol

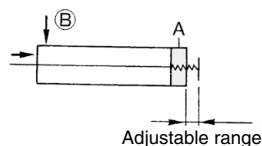

Precautions

⚠ Caution

- When air is supplied to the cylinder, if the stroke adjustment bolt is loosened in excess of the allowable stroke adjustment amount, be aware that the stroke adjustment bolt could fly off or air could be discharged, which could injure personnel or damage the peripheral equipment.
- Adjust the stroke when the cylinder is not pressurized. If it is adjusted while in a pressurized state, the seal of the adjustment section could become deformed, leading to air leakage.

Dimensions (Dimensions other than those below are the same as the standard type.)

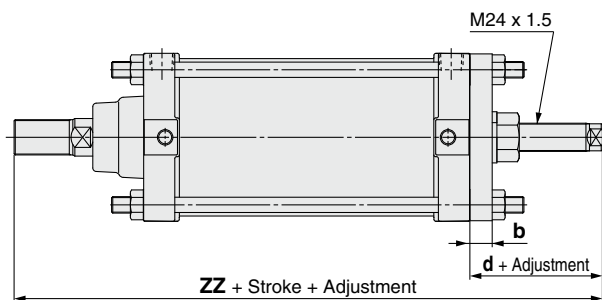

Bore size	a	b	d	ZZ	[mm]
125	142	19	63	271	
140	155	19	63	271	
160	174	19	59	285	

Standard Double Acting, Single Rod **CS2**
Double Acting, Double Rod **CS2W**
Long Stroke Double Acting, Single Rod **CS2-V**
Axial Centralized Piping Double Acting, Single Rod **CS2□P**

Auto Switch

Made to Order

6 Dual Stroke Cylinder/Double Rod Type

-XC10

Two cylinders are integrated into one in a back-to-back configuration allowing for the cylinder stroke to be controlled in three steps.

Applicable Series

Description	Model	Action	Note
Air cylinder	CS2	Double acting, Single rod	ø125 to ø160 only (* Excludes the clevis and trunnion types)

How to Order

CS2 **Mounting type** **Bore size** **Port suffix** - **Stroke A** **Suffix** + **Stroke B** **Suffix** - **XC10**
 * Excludes the clevis and trunnion types Dual stroke cylinder ●

Specifications

Series	Bore size [mm]	Max. manufacturable stroke [mm]
CS2	125, 140	1000
	160	1200

* Specifications other than the above are the same as the standard type.

Symbol

Function

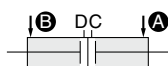

When air pressure is supplied to ports **A** and **B**, both strokes A and B retract.

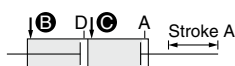

When air pressure is supplied to ports **B** and **C**, stroke A is operated.

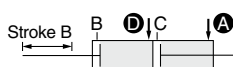

When air pressure is supplied to ports **A** and **D**, stroke B is operated.



When air pressure is supplied to ports **C** and **D**, both strokes A and B are operated.

Dimensions (Dimensions other than those below are the same as the standard type.)

Bore size	[mm]	
	S	ZZ
125	196	416
140	196	416
160	212	452

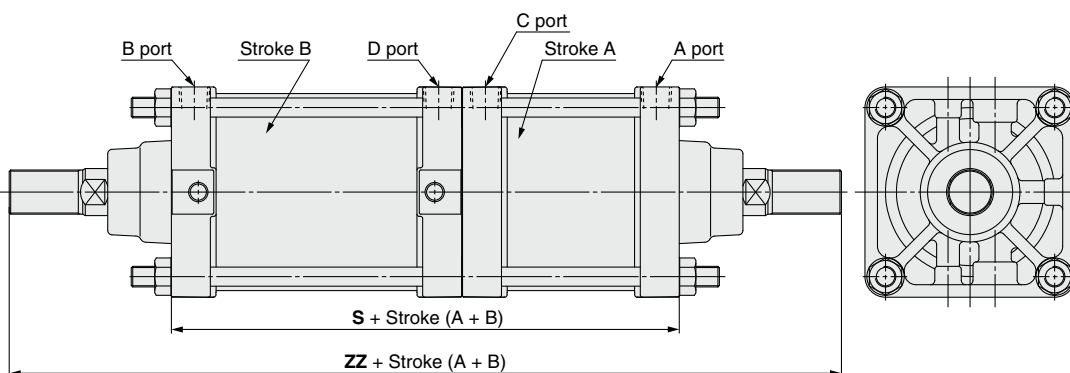

* For the rod flange type (F), the flange bracket will be attached on the stroke A side.

7 Dual Stroke Cylinder/Single Rod Type

Symbol
-XC11

Two cylinders can be integrated by connecting them in line, and the cylinder stroke can be controlled in two stages in both directions.

Applicable Series

Description	Model	Action	Note
Air cylinder	CS2	Double acting, Single rod	ø125 to ø160 only * Excludes the trunnion type

Specifications: Same as the standard type

(Please contact SMC for each manufacturable stroke length.)

How to Order

CS2 **Mounting type** **Bore size** **Port suffix** - **Stroke A** **Suffix** + **Stroke B-A** **Suffix** - **XC11**
 * Excludes the trunnion type

Dual stroke cylinder/Single rod type

Functional description of dual stroke cylinder

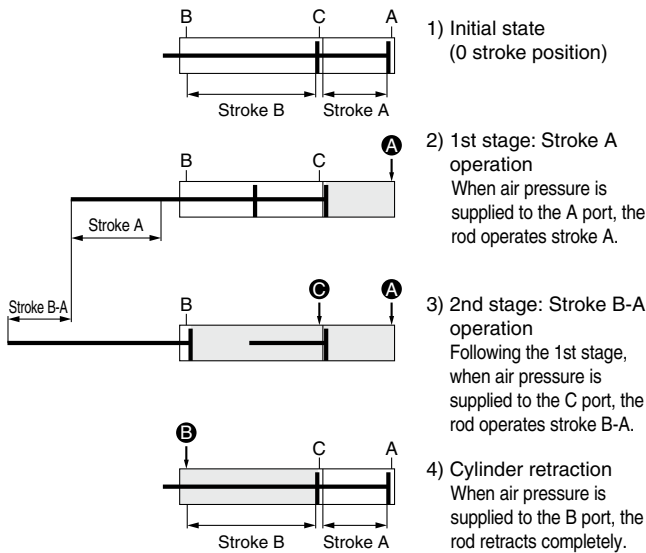

Stroke A and stroke B can be operated individually.

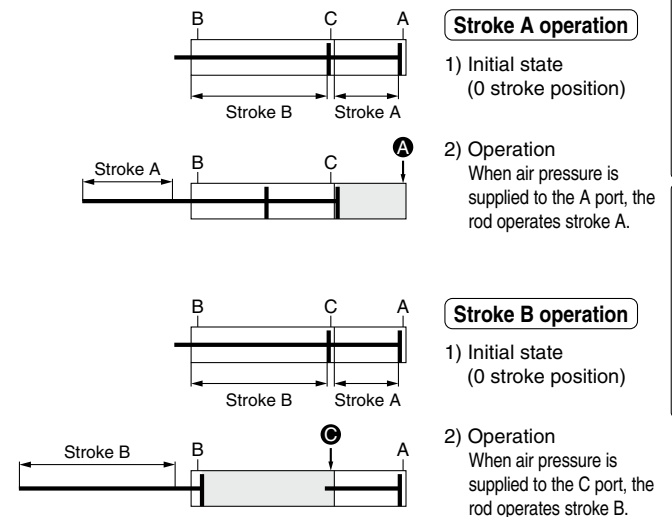

Double output is possible.

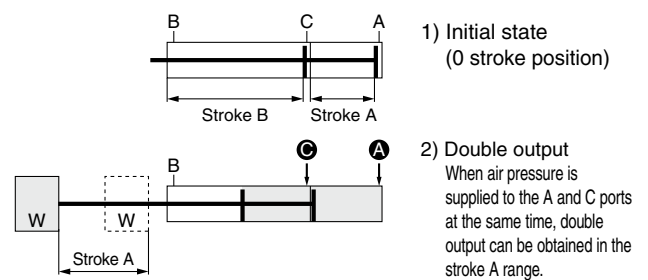

Precautions

⚠ Caution

1. Do not supply air until the cylinder is fixed with the attached bolt.
2. If air is supplied before securing the cylinder, the cylinder could lurch, posing a risk of bodily injury or damage to the peripheral equipment.

Dimensions (Dimensions other than those below are the same as the standard type.)

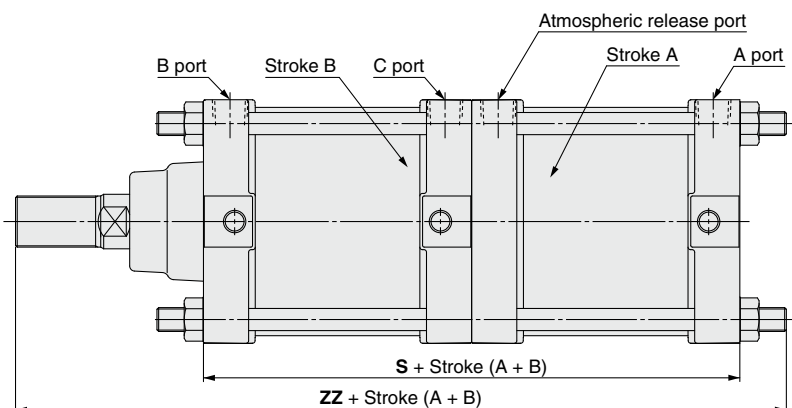

Bore size	[mm]	
	S	ZZ
125	197	334
140	197	334
160	213	363.5

Standard Double Acting, Single Rod **CS2**
 Double Acting, Double Rod **CS2W**
 Long Stroke Double Acting, Single Rod **CS2-V**
 Axial Centralized Piping Double Acting, Single Rod **CS2□P**
 Auto Switch
 Made to Order

8 Fluororubber Seal

Symbol

-XC22

Applicable Series

Description	Model	Action	Note
Air cylinder	CS2	Double acting, Single rod	ø125 to ø160 only
	CS2W	Double acting, Double rod	ø125 to ø160 only

How to Order

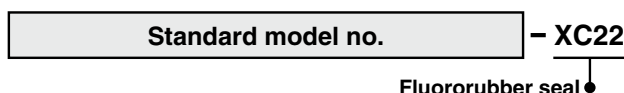

Specifications

Seal material	Fluororubber
Ambient temperature range	With auto switch : 0°C to 60°C Without auto switch: 0°C to 70°C (No freezing)*1
Specifications other than the above and external dimensions	Same as the standard type

*1 Please contact SMC, since the type of chemical and the operating temperature may not allow the use of this product.

* Cylinders with auto switches can also be produced; however, auto switch related parts (auto switch units, mounting brackets, built-in magnets) are the same as standard products. Before using these, please contact SMC regarding their suitability for the operating environment.

9 With Split Pins for Double Clevis Pin/Double Knuckle Joint Pin and Flat Washers

Symbol

-XC26

A flat washer has been added for the double clevis (one of the mounting types) or double knuckle joint (one of the accessories).

Applicable Series

Description	Model	Action	Note
Standard type	CS2	Double acting, Single rod	

How to Order

• Product



• Parts assembly

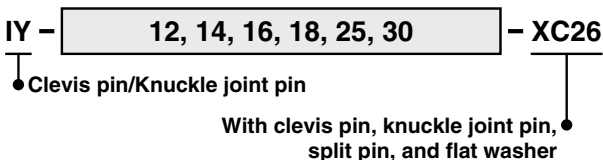
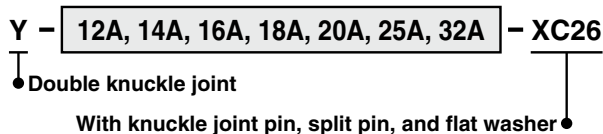
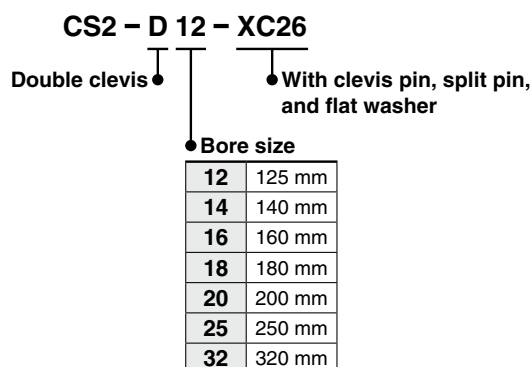

Specifications

Mounting type	Double clevis type (D), double knuckle joint only
Changed parts	Clevis pin, knuckle joint pin, flat washer
Specifications other than the above	Same as the standard type

Dimensions (Dimensions other than those below are the same as the standard type.)

Double clevis

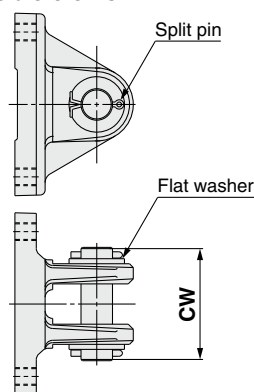

* The mounting bracket, split pin, clevis pin, and flat washer are shipped together but do not come assembled.

* Mounting method is the same as the standard type.

[mm]	
Bore size	CW
125	90
140	104
160	113
180	136
200	136
250	169
320	207

Double knuckle joint

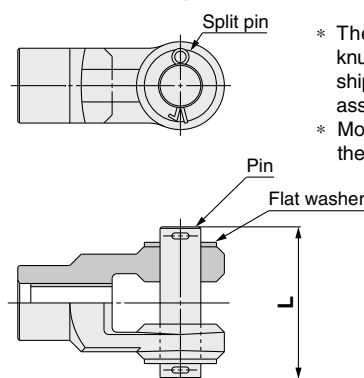

* The mounting bracket, split pin, knuckle joint pin and flat washer are shipped together but do not come assembled.

* Mounting method is the same as the standard type.

[mm]	
Bore size	L
125	90
140	104
160	113
180	136
200	136
250	169
320	207

10 Double Clevis and Double Knuckle Joint Pins Made of Stainless Steel

Symbol
-XC27

To prevent the oscillating portion of the double clevis or the double knuckle joint from rusting, the material of the pin and the retaining ring (split pin) has been changed to stainless steel.

Applicable Series

Description	Model	Action	Note
Standard type	CS2	Double acting, Single rod	

How to Order

CS2D Standard model no. - **XC27**
 • Double clevis type Double clevis pin made of stainless steel •

• Parts assembly

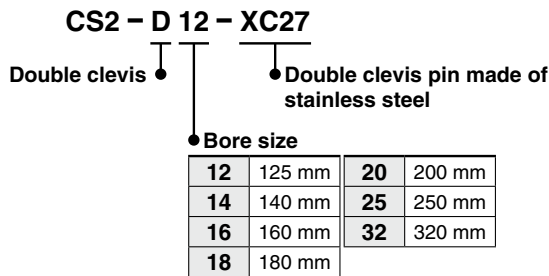

Y - 12A, 14A, 16A, 18A, 20A, 25A, 32A - **XC27**
 • Double knuckle joint Double knuckle joint pin made of stainless steel •

IY - 12, 14, 16, 18, 25, 30 - **XC27**
 • Clevis pin/Knuckle pin made of stainless steel •

Specifications

Mounting type	Double clevis type (D), double knuckle joint only
Changed parts	Clevis pin, knuckle joint pin, split pin
Specifications other than the above	Same as the standard type

Dimensions: Same as the standard type

* The mounting bracket, split pin, clevis pin, and knuckle joint pin are shipped together but do not come assembled.

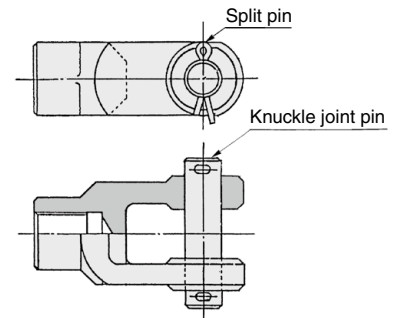

* Mounting method is the same as the standard type.

11 Rod Side Trunnion

Symbol
-XC30

This cylinder shortens the distance between the fulcrum and the rod end by installing a trunnion bracket in front of the rod side cover.

Applicable Series

Description	Model	Action	Note
Standard type	CS2	Double acting, Single rod	ø125 to ø160 only
	CS2W	Double acting, Double rod	ø125 to ø160 only

How to Order

CS2T Standard model no. - **XC30**
 • Trunnion bracket Rod side trunnion •

Specifications: Same as the standard type

Dimensions (Dimensions other than those below are the same as the standard type.)

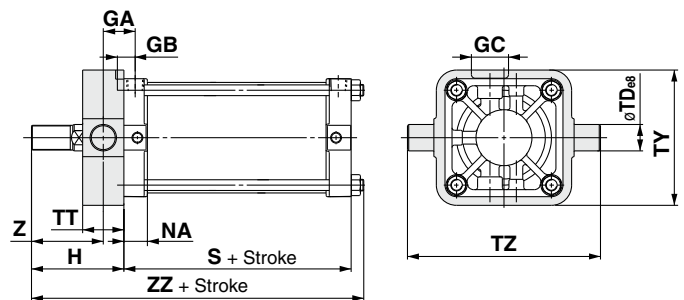

Bore size	GA	GB	GC	NA	S	TDe8	TT	TY	TZ	H	Z	ZZ
125	38	23	45	28.5	96	32 ^{+0.050} _{-0.089}	50	164	234	112	87	221
140	40.5	23	45	28.5	96	36 ^{+0.050} _{-0.089}	55	184	262	112	84.5	221
160	46	26	50	32.5	104	40 ^{+0.050} _{-0.089}	60	204	292	122	92	241

Standard Double Acting, Single Rod **CS2**
 Double Acting, Double Rod **CS2W**
 Long Stroke Double Acting, Single Rod **CS2-V**
 Axial Centralized Piping Double Acting, Single Rod **CS2-P**
 Auto Switch
 Made to Order

CS2 Series

12 With Coil Scraper

Symbol
-XC35

Removes frost, ice, weld spatter, cutting chips, etc. adhered to the piston rod, protecting the seals.

Applicable Series

Description	Model	Action	Note
Air cylinder	CS2	Double acting, Single rod	ø125 to ø160 only
	CS2W	Double acting, Double rod	ø125 to ø160 only

How to Order

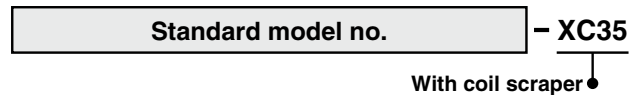

Specifications: Same as the standard type Dimensions: Same as the standard type

13 Made of Stainless Steel (With Hard Chrome Plated Piston Rod)

Symbol
-XC68

Suitable for cases where immersion in water leads to corrosion or the generation of rust.

Applicable Series

Description	Model	Action	Note
Standard type	CS2	Double acting, Single rod	
	CS2W	Double acting, Double rod	

Specifications

Parts changed to stainless steel	Piston rod
Specifications other than the above and external dimensions	Same as the standard type

How to Order

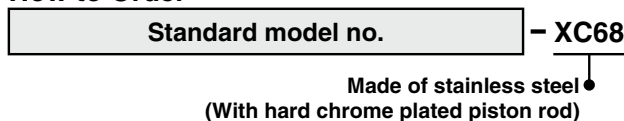

Maximum Strokes

Double acting, Single rod	Double acting single rod with rod boot
1600	1400

14 With Rod End Bracket

Symbol
-XC86

A model with the rod end bracket to simplify the order process

Applicable Series

Description	Model	Action	Note
Standard type	CS2	Double acting, Single rod	

How to Order

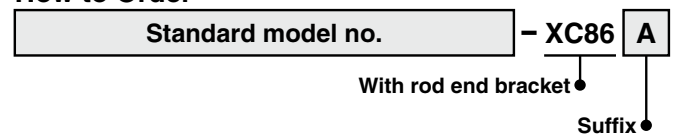

- * Rod end brackets are shipped together with the product but do not come assembled.
- * A pin and two split pins are attached for double knuckle joint.
- * XC86A to C: Standard type, XC86D to F: Standard type except for rod end thread length (A and H dimensions)

A	With rod end nut
B	With double knuckle joint
C	With single knuckle joint
D	With double knuckle joint and rod end nut
E	With single knuckle joint and rod end nut
F	With rod end nut (For knuckle joint)

Dimensions (Dimensions other than those below are the same as the standard type.)

XC86B, XC86C

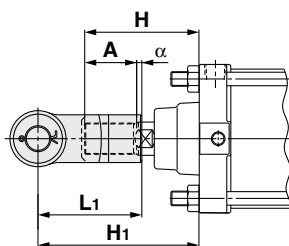

Symbol Bore size [mm]	H	A	α	L ₁	H ₁	Applicable knuckle joint part no.	
						I type single knuckle	Y type double knuckle
125	110	50	3.5	100	156.5	I-12A	Y-12A
140	110	50	3.5	105	161.5	I-14A	Y-14A
160	120	56	3.5	110	170.5	I-16A	Y-16A
180	135	63	3.5	125	193.5	I-18A	Y-18A
200	135	63	3.5	125	193.5	I-20A	Y-20A
250	160	71	3.5	160	245.5	I-25A	Y-25A
320	175	80	3.5	175	266.5	I-32A	Y-32A

XC86D, XC86E

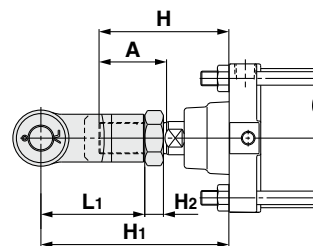

Symbol Bore size [mm]	H	A	L ₁	H ₁	H ₂	Applicable knuckle joint part no.		Applicable rod end nut
						I type single knuckle	Y type double knuckle	
125	125	65	100	181	18	I-12A	Y-12A	NT-12
140	125	65	105	186	18	I-14A	Y-14A	NT-12
160	140	76	110	198	21	I-16A	Y-16A	NT-16
180	155	83	125	223	23	I-18A	Y-18A	NT-18
200	160	88	125	227	27	I-20A	Y-20A	NT-20
250	195	106	160	287	34	I-25A	Y-25A	NT-25
320	210	115	175	312	38	I-32A	Y-32A	NT-30

XC86F

