

Locating Pin Cylinder

MGPL50-X2616

∅50

How to Order

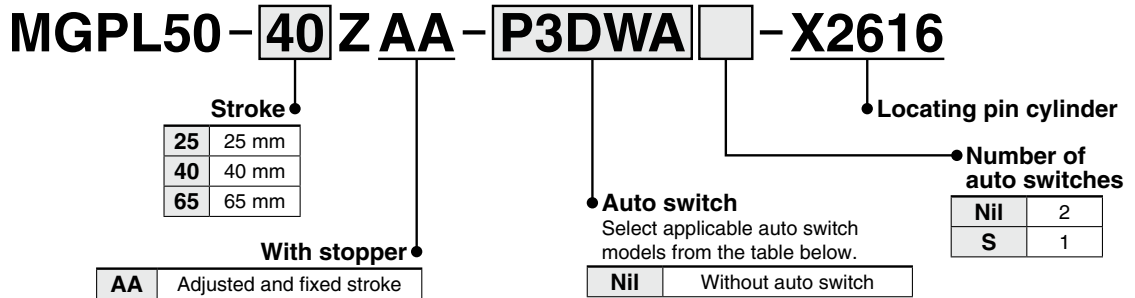

Auto Switch Models: Refer to Best Pneumatics No. 3 for further information on auto switches.

Magnetic Field Resistant Auto Switches

Type	Auto switch model	Applicable magnetic field	Electrical entry	Indicator light	Wiring (Pin no. in use)	Load voltage	Lead wire length	Applicable load
Solid state auto switch	D-P3DWASC	AC magnetic field (Single-phase AC welding magnetic field)	Pre-wired connector	2-color	2-wire (3-4)	24 VDC	0.3 m	Relay, PLC
	D-P3DWASE				2-wire (1-4)			
	D-P3DWA		Grommet		2-wire		0.5 m	
	D-P3DWAL						3 m	
	D-P3DWAZ		Pre-wired connector		2-wire (3-4)		5 m	
	P4DWSC*1						0.3 m	
	P4DWSE*1		Grommet		2-wire (1-4)		3 m	
	P4DWL*1						5 m	
P4DWZ*1								

*1: When the D-P4DW auto switches are mounted on the same surface, they may not be adjustable to the most sensitive position with a 25 mm stroke. The D-P3DWA is recommended in this case.

Small Auto Switches Small auto switches cannot be used under a strong magnetic field.

Type	Special function	Electrical entry	Indicator light	Wiring (Output)	Load voltage		Auto switch model		Lead wire length [m]				Pre-wired connector	Applicable load		
					DC	AC	Perpendicular	In-line	0.5 (Nil)	1 (M)	3 (L)	5 (Z)		IC circuit	PLC	
Solid state auto switch	—	Grommet	Yes	3-wire (NPN)	24 V	—	M9NV	M9N	●	●	●	○	○	IC circuit	Relay, PLC	
				3-wire (PNP)			M9PV	M9P	●	●	●	○				
				2-wire			M9BV	M9B	●	●	●	○				
				3-wire (NPN)			M9NWV	M9NW	●	●	●	○				
	Diagnostic indication (2-color indicator)			Water resistant (2-color indicator)	3-wire (PNP)	5 V, 12 V	M9PWV	M9PW	●	●	●	○	○	○		IC circuit
					2-wire	12 V	M9B WV	M9BW	●	●	●	○	○	○		—
					3-wire (NPN)	5 V, 12 V	M9NAV	M9NA	○	○	●	○	○	○		IC circuit
					3-wire (PNP)	5 V, 12 V	M9PAV	M9PA	○	○	●	○	○	○		—
Reed auto switch	—	Grommet	No	3-wire (NPN equivalent)	—	5 V	A96V	A96	●	—	●	—	—	IC circuit	—	
				2-wire	12 V	100 V	A93V*1	A93	●	●	●	●	—	—	Relay, PLC	
					5 V, 12 V	100 V or less	A90V	A90	●	—	●	—	—	—	IC circuit	

*1: 1 m lead wire is only applicable to the D-A93.

*: Solid state auto switches marked with "○" are produced upon receipt of order.

*: Auto switches and mounting brackets are shipped together, (but not assembled).

*: Lead wire length symbols: 0.5 m.....Nil (Example) M9NWV
 1 m.....M (Example) M9NWVM
 3 m.....L (Example) M9NWVL
 5 m.....Z (Example) M9NWVZ

Specifications

Bore size [mm]	50		
Stroke [mm]	25	40	65
Maximum operating pressure	1.0 MPa		
Proof pressure	1.5 MPa		
Minimum operating pressure	0.14 MPa		
Ambient temperature	-10 to 60°C		
Fluid temperature	-10 to 60°C		
Cushion	Rubber bumper on both ends (Extended end stopped by stroke adjustment stopper.)		
Weight	4.4 kg	4.7 kg	4.9 kg

End Plate Deflection

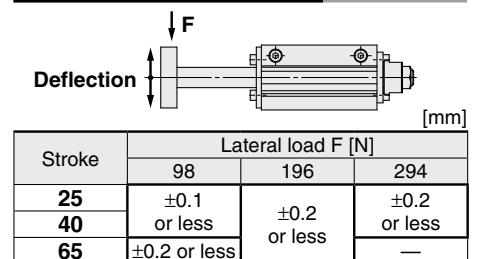

Dimensions

MGPL50-□ZAA-□-X2616

※: With auto switch (D-P3DWA)

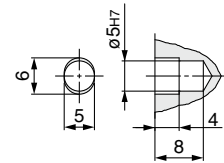
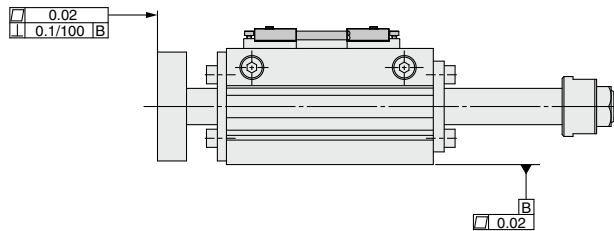
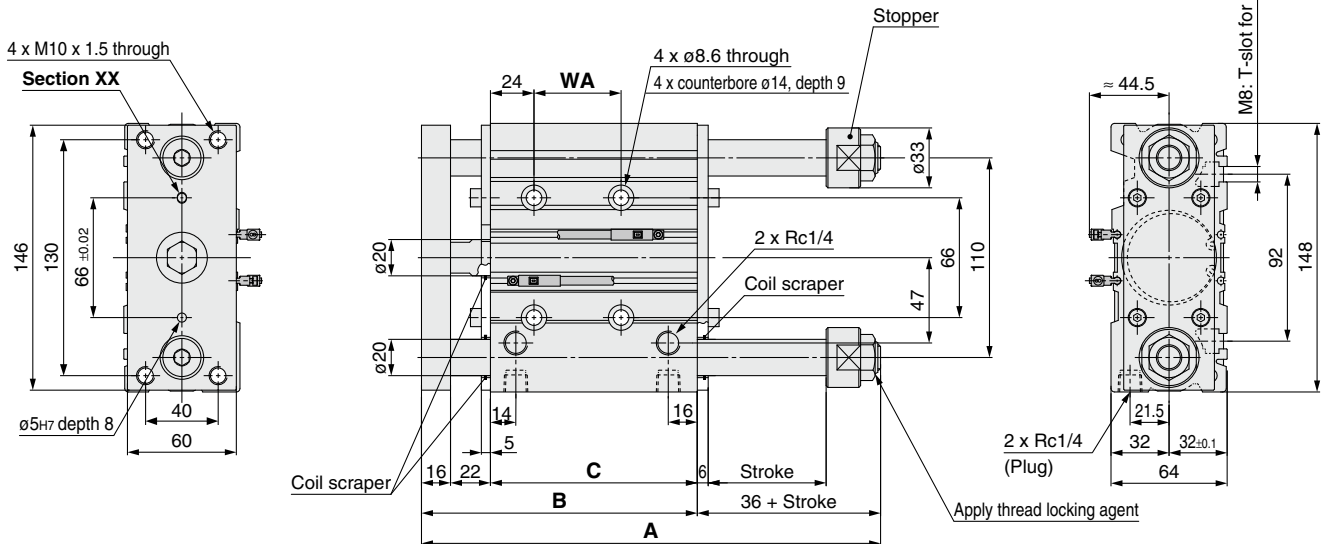
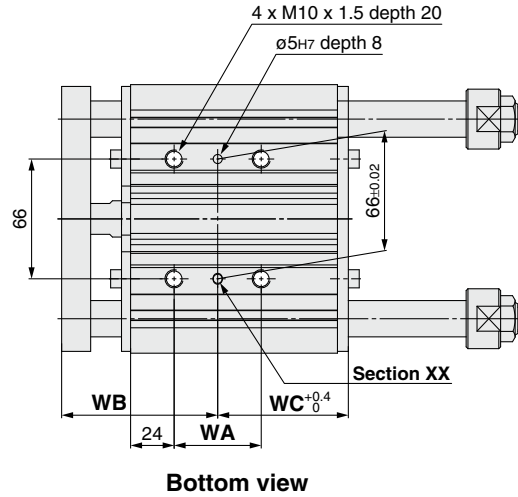
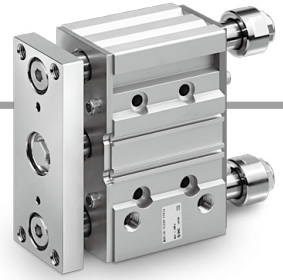

Section XX details

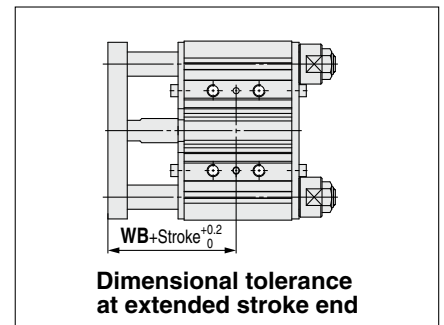

	A	B	C	WA	WB	WC
25 mm stroke	188	127	89	38	81	52
40 mm stroke	203	127	89	38	81	52
65 mm stroke	253	152	114	48	86	72

※: The stopper of the cylinder cannot be adjusted. (Marking on stopper nut)
When readjustment of the stopper is performed by another company, SMC will not guarantee the dimensional tolerance of WB + stroke^{+0.2}₀.

MGPL50-X2616

Auto Switch Proper Mounting Position (Detection at stroke end) and Mounting Height

D-P3DWA

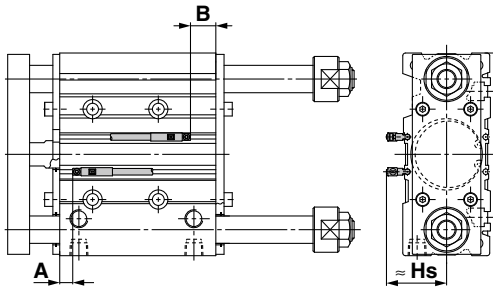

D-M9□(V)/D-M9□W(V) D-M9□A(V)/D-A9□(V)

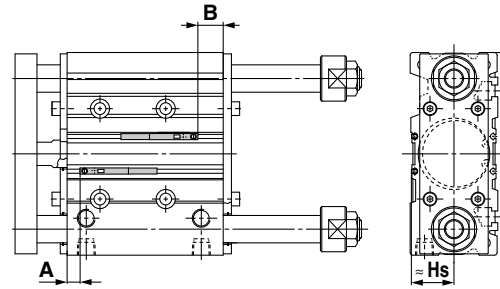

D-P4DW

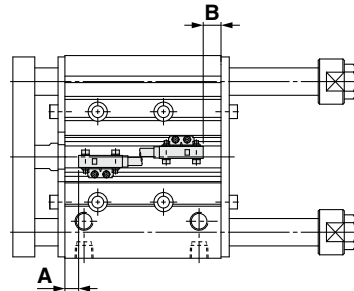
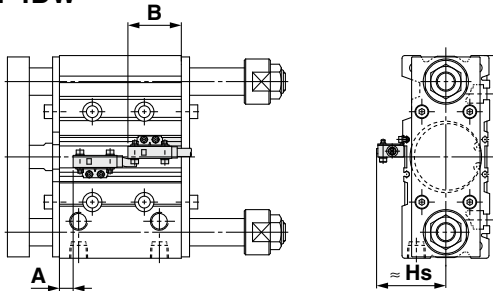

40 mm stroke: D-P4DW□.....When two switches are mounted.

65 mm stroke: D-P4DW□.....When two switches are mounted.

Auto Switch Proper Mounting Position [mm]

Auto switch model	Applicable stroke	D-P3DWA		D-P4DW		D-M9□(V) D-M9□W(V) D-M9□A(V)		D-A9□(V)	
		A	B	A	B	A	B	A	B
Bore size 50	25	24.5	18.5	—	—	29	23	25	19
	40	9.5	18.5	7	42	14	23	10	19
	65	9.5	18.5	7	16	14	23	10	19

Auto Switch Proper Mounting Height [mm]

Auto switch model	D-P3DWA	D-P4DW	D-M9□V D-M9□WV D-M9□AV	D-A9□V
	Bore size 50	Hs 44.5	Hs 50.5	Hs 38.5

Operating Range

Auto switch model	Operating range [mm]
D-P3DWA	6
D-P4DW	5
D-M9□(V) D-M9□W(V) D-M9□A(V)	6
D-A9□(V)	9.5

*: Values which include hysteresis are for guideline purposes only, they are not a guarantee (assuming approximately ±30% dispersion) and may change substantially depending on the ambient environment.

Auto Switch Mounting Bracket Part No./Mounting Method

Applicable auto switch	D-P3DWA	D-M9□ D-A93	D-A9□ (Except D-A93)
Auto switch mounting bracket part no.	No mounting bracket required as the auto switch is directly mounted.		
Auto switch tightening torque	0.2 to 0.3 N·m	0.05 to 0.15 N·m	0.1 to 0.2 N·m

Applicable auto switch	D-P4DW	
Auto switch mounting bracket part no.	BMG7-032	
Auto switch tightening torque	M3: 0.5 to 0.6 N·m, M2.5: 0.25 to 0.35 N·m	
Auto switch mounting bracket fitting parts lineup/weight	<ul style="list-style-type: none"> Auto switch mounting bracket Auto switch mounting nut Hexagon socket head cap screw (M3 x 0.5 x 14 L, With spring washer) 	<ul style="list-style-type: none"> Hexagon socket head cap screw (M2.5 x 0.45 x 5 L) Spring washer (for M2.5) Weight = 12 g

⚠ Safety Instructions Be sure to read the "Handling Precautions for SMC Products" (M-E03-3) and "Operation Manual" before use.