

隔板 (X)



Y200



Y400

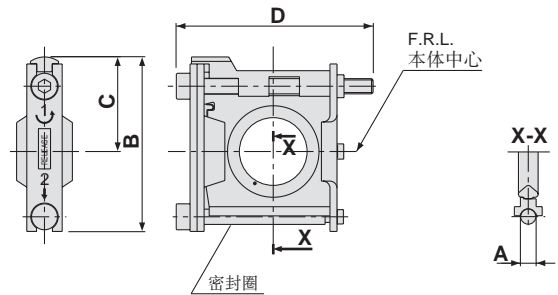

型号	A	B	C	D	适合型号
Y100	6	27	15	33	AC10·AC10A·AC10B
Y200	3	35.5	18.5	48	AC20·
Y300	4	47	26	59	AC25□·AC30□
Y400	5	57	31	65	AC40□
Y500	5	61	33	70	AC40□-06
Y600	6	75.5	41	86	AC50·AC55·AC60 AC50B·AC55B·AC60B

可换件

名称	材料	零件型号					
		Y100	Y200	Y300	Y400	Y500	Y600
密封圈	NBR	注) Y100P-060AS	Y200P-060S	Y300P-060S	Y400P-060S	Y500P-060S	Y600P-060S

注) O 形圈 2 个为一组

带托架的隔板 (Z)



Y200T

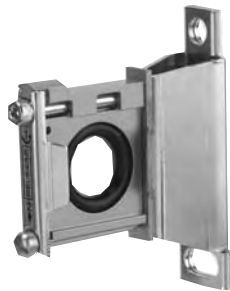

Y400T

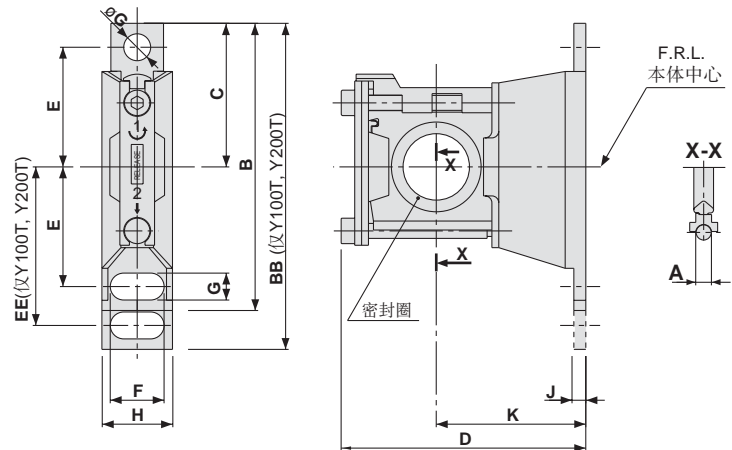

型号	A	B	BB	C	D	E	EE	F	G	øG	H	J	K	适合型号
Y100T	6	-	56	24.5	40.5	20	27	6.8	4.5	4.5	14	2.8	25	AC10□
Y200T	3	-	67	29	53	24	33	12	5.5	5.5	19	3.2	30	AC20□
Y300T	4	82	-	41	68	35	-	14	7	7	21	4	41	AC25□·AC30□
Y400T	5	96	-	48	81.5	40	-	18	9	9	26	4	50	AC40□
Y500T	5	96	-	48	86	40	-	18	9	9	27	4.6	50	AC40□-06
Y600T	6	120	-	60	112	50	-	20	11	11	31	6.4	70	AC50·AC55·AC60·AC50B·AC55B·AC60B

可换件

名称	材料	零件型号					
		Y100T	Y200T	Y300T	Y400T	Y500T	Y600T
密封圈	NBR	注) Y100P-060AS	Y200P-060S	Y300P-060S	Y400P-060S	Y500P-060S	Y600P-060S

注) O 形圈 2 个为一组