

# Suction Guard (Produced upon receipt of order)

# FHG Series



## Designed to prevent collected dust from falling into the tank

All collected dust can be disposed completely when the element is replaced. There is no danger of collected matter dropping back into the tank.

## No need to replace flushing oil

Since all dust is eliminated during trial operation, it is not necessary to replace flushing oil. This reduces both labor and wasted oil.

## Easy maintenance and no air mixing

No special tools are required for maintenance, and insertion-type element replacement is quick and easy. This helps prevent air mixture into the suction line and pump damage.

## Compact tank equipment

The lubrication port strainer, suction filter, and air breather are all integrated into a single unit, reducing the volume of equipment around the tank.

## Selection of connection methods and accessories for a variety of applications

Six methods are available as standard. Differential pressure indicators (visual and switch) are available and can be selected to match the application.

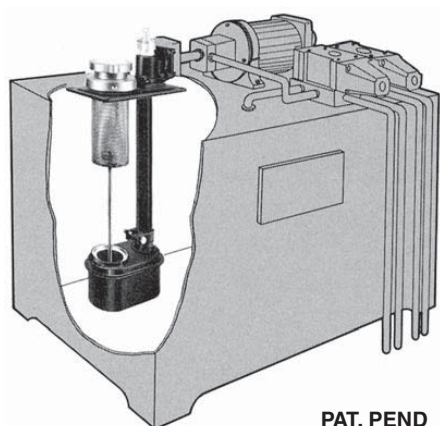

PAT. PEND

## Specifications

Fluid		Hydraulic fluid
Operating pressure		Negative pressure
Operating temperature		Max. 80°C
Main material	Top flange	Steel plate
	Case	Steel plate
	Inlet pipe	Steel plate
	O-ring	NBR or FKM <sup>Note)</sup>
	Seal	NBR or EPDM <sup>Note)</sup>
Element	Material	Stainless steel, Carbon steel, Aluminum, Epoxy resin
	Nominal filtration	74, 105, 149 μm (200, 150, 100 mesh)
	Differential pressure resistance	0.2 MPa
Differential pressure indicator operating pressure (Element replacement differential pressure)		24.0 kPa
Air breather nominal filtration		40 μm
Lubrication port strainer nominal filtration		10 mesh or equivalent

Note) The material of the O-rings and seals differs depending on the hydraulic fluid used.  
Petroleum, Water-glycol, Emulsion: NBR; Phosphoric ester: FKM, EPDM

## Connection

Companion flange, Female threaded companion flange, L-block companion flange, L-block female threaded companion flange, S-block companion flange, S-block female threaded companion flange
---

Note 1) Female threaded connection ports are 1/2<sup>B</sup> to 2<sup>B</sup> only.

Note 2) Flange configuration is exclusive to SMC.

## Model/Rated Flow Rate

Model	Port size	Rated flow rate (L/min)
FHG9□A□-M□-04	1/2 <sup>B</sup>	18
FHG9□A□-M□-06	3/4 <sup>B</sup>	32
FHG9□A□-M□-08	1 <sup>B</sup>	53
FHG9□B□-M□-10	1 1/4 <sup>B</sup>	90
FHG9□B□-M□-12	1 1/2 <sup>B</sup>	120
FHG9□B□-M□-16	2 <sup>B</sup>	200
FHG9□C□-M□-20	2 1/2 <sup>B</sup>	315
FHG9□C□-M□-24	3 <sup>B</sup>	450

## Accessory/Option

Description	Part no.	Note	
Differential pressure indicator	CB-21H	Petroleum, Water-glycol, Emulsion	
	CB-21H-V	Phosphoric ester	
Differential pressure indication switch (N.C. and N.O. common)	CB-67H	Petroleum, Water-glycol, Emulsion	
	CB-67H-V	Phosphoric ester	
Air breather	CW-4H	Petroleum	
	CW-4H-W	For 1/2 <sup>B</sup> to 1 <sup>B</sup>	Water-glycol, Emulsion
	CW-4H-V		Phosphoric ester
	CW-5H	Petroleum	
	CW-5H-W	For 1 1/4 <sup>B</sup> to 2 <sup>B</sup>	Water-glycol, Emulsion
	CW-5H-V		Phosphoric ester
	CW-6H	Petroleum	
	CW-6H-W	For 2 1/2 <sup>B</sup> , 3 <sup>B</sup>	Water-glycol, Emulsion
	CW-6H-V		Phosphoric ester
Cap	D-73H	Petroleum	
	D-73H-W	For 1/2 <sup>B</sup> to 1 <sup>B</sup>	Water-glycol, Emulsion
	D-73H-V		Phosphoric ester
	D-74H	Petroleum	
	D-74H-W	For 1 1/4 <sup>B</sup> to 2 <sup>B</sup>	Water-glycol, Emulsion
	D-74H-V		Phosphoric ester
	D-75H	Petroleum	
	D-75H-W	For 2 1/2 <sup>B</sup> , 3 <sup>B</sup>	Water-glycol, Emulsion
	D-75H-V		Phosphoric ester

**How to Order**

**FHG9 0 A - M 074 - 04 - 0 0**

Suction guard

Hydraulic fluid

0	Petroleum
1	Water-glycol, Emulsion
2	Phosphoric ester

Port size category

A	1/2 <sup>B</sup> , 3/4 <sup>B</sup> , 1 <sup>B</sup>
B	1 1/4 <sup>B</sup> , 1 1/2 <sup>B</sup> , 2 <sup>B</sup>
C	2 1/2 <sup>B</sup> , 3 <sup>B</sup>

Length below flange neck (T dimension)

Port size (Nominal size)	Standard T dimension			T dimension when shipped (Max. T dimension)
	Symbol	Length (mm)	Adjustment range (mm)	
04 (1/2 <sup>B</sup> ) 06 (3/4 <sup>B</sup> ) 08 (1 <sup>B</sup> )	1	310	±30	340
	2	380		410
	3	450		480
	4	520		550
	5	590		620
10 (1 1/4 <sup>B</sup> ) 12 (1 1/2 <sup>B</sup> ) 16 (2 <sup>B</sup> )	1	385	±45	430
	2	485		530
	3	585		630
	4	685		730
20 (2 1/2 <sup>B</sup> ) 24 (3 <sup>B</sup> )	1	560	Fixed	560
	2	650		650
	3	750		750
	4	850		850

Note) Refer to page 509 for the T dimension.

Port size

04	1/2 <sup>B</sup>
06	3/4 <sup>B</sup>
08	1 <sup>B</sup>
10	1 1/4 <sup>B</sup>
12	1 1/2 <sup>B</sup>
16	2 <sup>B</sup>
20	2 1/2 <sup>B</sup>
24	3 <sup>B</sup>

Nominal filtration

074	74 μm
105	105 μm
149	149 μm

Element

M	Micromesh
---	-----------

Air breather

Nil	Air breather
C	Cap

Connection

0	Companion flange
1	Female threaded companion flange
2	L-block companion flange
3	L-block female threaded companion flange
4	S-block companion flange
5	S-block female threaded companion flange

Differential pressure indication

0	None
1	Differential pressure indicator
5	Differential pressure indication switch <sup>Note)</sup>

Note) N.C. and N.O. common

Note) When the differential pressure indication "1 or 5" is selected, the connection method is "2 to 5." ("0 and 1" cannot be selected.)

**Replacement Element Part No. (Including O-ring for element)**

Port size (Nominal size)	74 μm (200 mesh)	105 μm (150 mesh)	149 μm (100 mesh)	Element size
04 (1/2 <sup>B</sup> ), 06 (3/4 <sup>B</sup> ), 08 (1 <sup>B</sup> )	EM220-074N	EM220-105N	EM220-149N	ø70 x 90
10 (1 1/4 <sup>B</sup> ), 12 (1 1/2 <sup>B</sup> ), 16 (2 <sup>B</sup> )	EM320-074N	EM320-105N	EM320-149N	ø90 x 125
20 (2 1/2 <sup>B</sup> ), 24 (3 <sup>B</sup> )	EM420-074N	EM420-105N	EM420-149N	ø110 x 190

Note 1) The symbol at the end of the element part no. indicates the hydraulic fluid type.

N: Petroleum, V: Phosphoric ester, W: Water-glycol, Emulsion.

Note 2) Refer to page 528 for non-standard filtration.

Note 3) Above elements require one element per filter.

**Construction/Seal List**

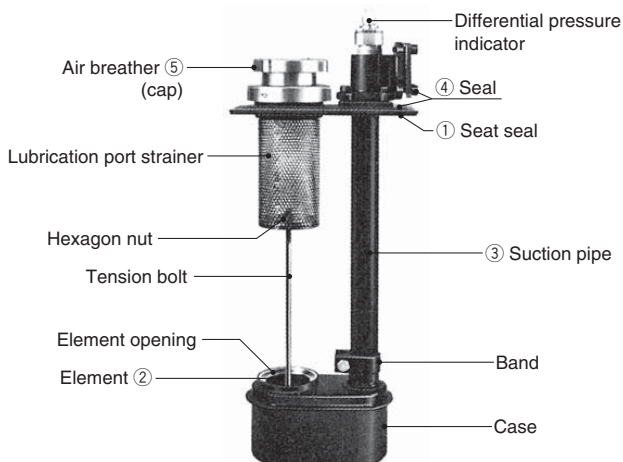

**Replacement O-ring/Seal List (One each of the seal and O-ring types listed below are required per filter.)**

Port size	Material	① Seal order no.	② O-ring order no.	③ O-ring order no.	④ Seal order no.	⑤ Seal order no.
			(Nominal size)	(Nominal size)		
04 to 08	NBR	AL-180H	KA00463	KA00080	AL-183H	AL-162H
			(1A-G65)	(1A-P34)		
			KA00793	KA00808		
10 to 16		AL-181H	(1A-G85)	(1A-P60)	AL-184H	AL-163H
20 to 24		AL-182H	KA00065	—	AL-185H	AL-164H
04 to 08	FKM or EPDM	AL-180H-V	KA00614	KA00105	AL-183H-V	AL-162H-V
			(4D-G65)	(4D-P34)		
			KA00703	KA00733		
10 to 16		AL-181H-V	(4D-G85)	(4D-P60)	AL-184H-V	AL-163H-V
20 to 24		AL-182H-V	KA00705	—	AL-185H-V	AL-164H-V
			(4D-G95)			

Note 1) The material of seals (AL-162H-V to AL-164H-V and AL-180H-V to AL-182H-V) is EPDM.

Note 2) When connection method "2 to 5" is selected, two ④ seals are required.

## Flow Rate Characteristics

### FHG Series

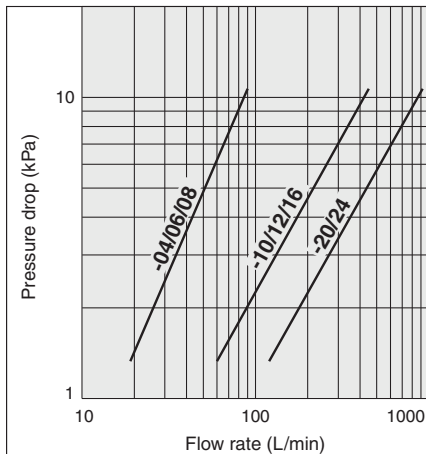

Conditions Fluid: Turbine oil Class 2 VG32  
 Viscosity: 45 mm<sup>2</sup>/s  
 Filter material: Micromesh  
 Nominal filtration: 74 μm

## Differential Pressure Indication

### ■ Differential pressure indication switch

- Operating pressure—24 kPa
- When a value has been displayed, it will be automatically reset when the pump is stopped. (Non-reset type)
- The element should be replaced when the switch is actuated.
- N.C. and N.O. common

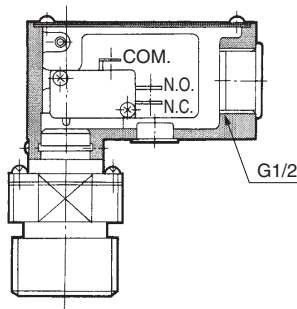

\* Refer to page 529 for “Microswitch for differential pressure indication switch”.

## Handling Precautions

### ② Operation

- The hydraulic fluid used becomes high viscosity when the temperature is low during the winter, etc., and the differential pressure indicator or the switch may activate. If this occurs, wait until the oil temperature rises by a warm-up operation, then check if this is caused by clogging.
- Once the differential pressure indicator is triggered, the indication continues to be displayed until the indicator is reset (by depressing the reset button), even if the pump stops operating.  
Reset after replacing the element and restarting operation, or after normal operation starts in cold weather such as during winter.
- When using a differential pressure indication switch and if a filter clogged signal is incorporated into the sequence circuit of the machine, make sure to design the system so the filter clogged signal does not operate until normal operation starts.

### ③ Element replacement

- When the pressure difference reaches 24 kPa during filter operation (triggering the differential pressure indicator), stop operation and either wash or replace the element.
- When replacing the element, check the O-rings and replace them if they are damaged.
- When installing and removing an element, do not scratch or damage it by touching the corners of the case, etc.
- When washing the element, do not wipe it using a stiff brush or rag.

### ④ Removing the element

- Rotate the air breather (cap) one-third of a turn counterclockwise and remove it. Grasp the handle of the lubrication port strainer inside and, while rotating it clockwise, pull it up vertically. The suction element is screwed onto one end of the tension bolt and along with the lubrication port strainer, can be removed and installed freely. Do not remove the suction element while the pump is operating.

### ⑤ T dimension (length below flange neck) adjustment

- The product is shipped from the factory with the maximum T dimension, so the user must adjust it to the required T dimension.
- The T dimension adjustment range, relative to the standard T dimension, is ±30 mm for 1/2<sup>B</sup> to 1<sup>B</sup> and ±45 mm for 1 1/4<sup>B</sup> to 2<sup>B</sup>. The dimension for 2 1/2<sup>B</sup> to 3<sup>B</sup> is fixed, so no adjustment is possible.
- Refer to the operating manual for details of the adjustment method.

### ⑥ Lubrication

- Remove the air breather (cap) and lubricate through the lubrication port strainer. Be careful not to let oil, etc., get onto the cap while it is being removed.

## Differential Pressure Indication

Two indication methods are available: differential pressure indicator and differential pressure indication switch. These can be mounted on all filter models.

Direct mounting is possible if the connection method is L-block or S-block. Otherwise, an Rc1 female thread fitting is required.

In addition, if no differential pressure indication is required, use a commercially available plug (R1).

### ■ Differential pressure indicator

- Operating pressure—24 kPa
- Once a value is displayed, it will continue to be displayed until reset, even if the pump is stopped. (Reset type)
- The element should be replaced when the red indication is visible.

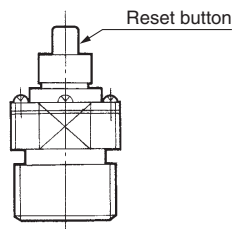

## Handling Precautions

### ① Mounting

- The portion of the suction guard below the oil tank mounting flange is installed inside the oil tank, so check to make sure it is clean when mounting it. For maintenance, make sure to provide sufficient space above the filter for removing the element.
- Use caution to ensure airtightness when connecting an outlet and installing a differential pressure indicator (especially for the thread type).
- Ensure that the oil tank fluid volume (minimum fluid level MIN(r) dimension) is 30 mm for 1/2<sup>B</sup> to 1<sup>B</sup>, 60 mm for 1 1/4<sup>B</sup> to 1 1/2<sup>B</sup>, 80 mm for 2<sup>B</sup>, and 120 mm or more for 2 1/2<sup>B</sup> to 3<sup>B</sup>, measured when there is no turbulence in the flow from the element opening or fluctuation in the fluid level. Also, select a T dimension (length below flange neck) that will ensure that the fluid level does not reach the lubrication port strainer.

## Dimensions

Port size: 04 to 16

Port size: 20, 24

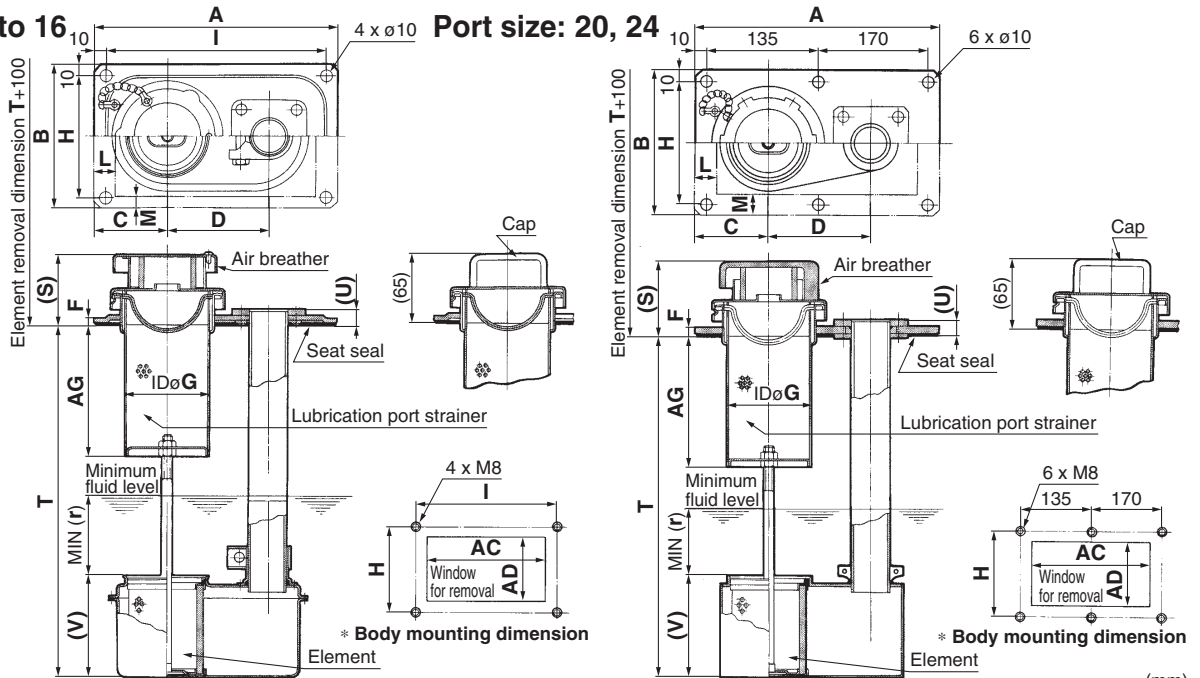

\* Body mounting:  
Cut-out processing of the window is required for the customer's tank.  
\* Body mounting dimension

Port size (Nominal size)	A	B	C	D	F	G	H	I	L	M	S	U	V	r	AC	AD	AG	Standard T dimension					T dimension adjustment range		
																		1	2	3	4	5			
1/2 <sup>B</sup> (04)	215	130	65	90	6	72	110	195	19	10	63	14	90	30	177	110	120	310	380	450	520	590	±30		
3/4 <sup>B</sup> (06)	215	130	65	90	6	72	110	195	19	10	63	14	90	30	177	110	120								
1 <sup>B</sup> (08)	215	130	65	90	6	72	110	195	19	10	63	14	90	30	177	110	120								
1 1/4 <sup>B</sup> (10)	265	150	75	115	6	86	130	245	19	10	63	17	126	60	227	130	140	385	485	585	685	—	±45		
1 1/2 <sup>B</sup> (12)	265	150	75	115	6	86	130	245	19	10	63	17	126	60	227	130	140								
2 <sup>B</sup> (16)	265	150	75	115	6	86	130	245	19	10	63	17	126	80	227	130	140								
2 1/2 <sup>B</sup> (20)	325	190	85	145	8	106	170	—	20	20	76	17	197	120	285	150	170	560	650	750	850	—	Fixed		
3 <sup>B</sup> (24)	325	190	85	145	8	106	170	—	20	20	76	17	197	120	285	150	170								

### Connection part dimensions/ Companion flange

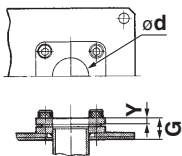

Port size	d	G	Y	Weight (kg)*
1/2 <sup>B</sup> (04)	22.2	25	9	2.7
3/4 <sup>B</sup> (06)	27.7	25	9	2.7
1 <sup>B</sup> (08)	34.5	25	9	2.7
1 1/4 <sup>B</sup> (10)	43.9	28	9	5.1
1 1/2 <sup>B</sup> (12)	49.1	28	9	5.1
2 <sup>B</sup> (16)	61.1	28	9	5.0
2 1/2 <sup>B</sup> (20)	77.1	28	9	10.3
3 <sup>B</sup> (24)	90.0	28	9	10.3

\* Weight values are for the minimum T dimension (symbol 1) in each standard T dimension.

### Female threaded companion flange

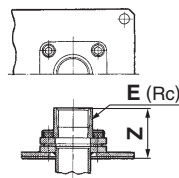

Port size	E	Z	Weight (kg)*
1/2 <sup>B</sup> (04)	1/2	47	2.8
3/4 <sup>B</sup> (06)	3/4	47	2.8
1 <sup>B</sup> (08)	1	52	2.8
1 1/4 <sup>B</sup> (10)	1 1/4	58	5.3
1 1/2 <sup>B</sup> (12)	1 1/2	58	5.3
2 <sup>B</sup> (16)	2	63	5.4

\* Weight values are for the minimum T dimension (symbol 1) in each standard T dimension.

### L-type block companion flange

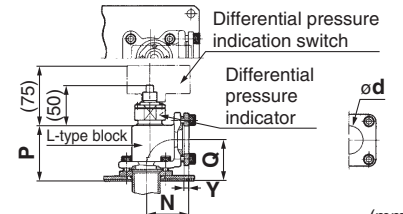

Port size	d	N	P	Q	Y	Weight (kg)*
1/2 <sup>B</sup> (04)	22.2	56	71	53	9	3.6
3/4 <sup>B</sup> (06)	27.7	56	71	53	9	3.6
1 <sup>B</sup> (08)	34.5	56	71	53	9	3.6
1 1/4 <sup>B</sup> (10)	43.9	76	104	74	9	7.3
1 1/2 <sup>B</sup> (12)	49.1	76	104	74	9	7.3
2 <sup>B</sup> (16)	61.1	76	104	74	9	7.1
2 1/2 <sup>B</sup> (20)	77.1	101	129	94	9	14.5
3 <sup>B</sup> (24)	90.0	101	129	94	9	14.5

\* Weight values are for the minimum T dimension (symbol 1) in each standard T dimension.  
\* The "OUT" direction can be mounted up to 90° to the left or right.

### L-type block female threaded companion flange

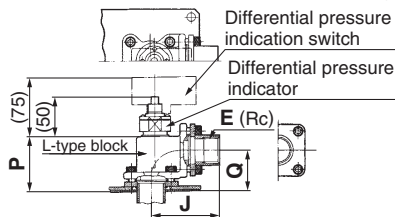

Port size	E	J	P	Q	Weight (kg)*
1/2 <sup>B</sup> (04)	1/2	78	71	53	3.7
3/4 <sup>B</sup> (06)	3/4	78	71	53	3.7
1 <sup>B</sup> (08)	1	83	71	53	3.7
1 1/4 <sup>B</sup> (10)	1 1/4	106	104	74	7.4
1 1/2 <sup>B</sup> (12)	1 1/2	106	104	74	7.4
2 <sup>B</sup> (16)	2	111	104	74	7.5

\* Weight values are for the minimum T dimension (symbol 1) in each standard T dimension.  
\* The "OUT" direction can be mounted up to 90° to the left or right.

### S-type block companion flange

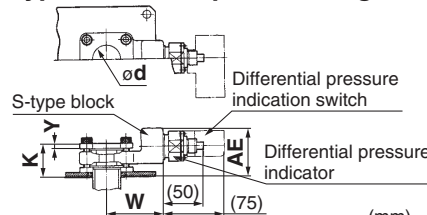

Port size	d	K	W	Y	AE	Weight (kg)*
1/2 <sup>B</sup> (04)	22.2	47	70	9	62	3.5
3/4 <sup>B</sup> (06)	27.7	47	70	9	62	3.5
1 <sup>B</sup> (08)	34.5	47	70	9	62	3.5
1 1/4 <sup>B</sup> (10)	43.9	50	85	9	65	6.2
1 1/2 <sup>B</sup> (12)	49.1	50	85	9	65	6.2
2 <sup>B</sup> (16)	61.1	50	85	9	65	6.1
2 1/2 <sup>B</sup> (20)	77.1	50	105	9	65	11.9
3 <sup>B</sup> (24)	90.0	50	105	9	65	11.9

\* Weight values are for the minimum T dimension (symbol 1) in each standard T dimension.  
\* The differential pressure indication entry can be mounted up to 90° to the left or right.

### S-type block female threaded companion flange

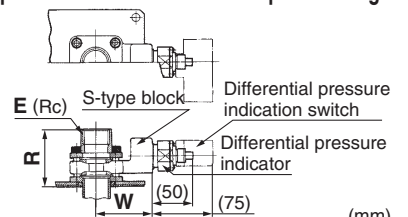

Port size	E	R	W	Weight (kg)*
1/2 <sup>B</sup> (04)	1/2	69	70	3.6
3/4 <sup>B</sup> (06)	3/4	69	70	3.6
1 <sup>B</sup> (08)	1	74	70	3.6
1 1/4 <sup>B</sup> (10)	1 1/4	80	85	6.4
1 1/2 <sup>B</sup> (12)	1 1/2	80	85	6.4
2 <sup>B</sup> (16)	2	85	85	6.5

\* Weight values are for the minimum T dimension (symbol 1) in each standard T dimension.  
\* The differential pressure indication entry can be mounted up to 90° to the left or right.