

CEU2 Controller

Controller CEU2/Specifications

Model	CEU2	CEU2P
Type	Controller	
Mounting	Surface mounting (DIN rail or screw stop)	
Operation mode	PRESET mode, PROGRAM mode, RUN mode	
Display system	LCD (with back light)	
No. of digits	Program 1 to 16, Step 1 to 32	
Position control system	P.T.P control (point to point)	
No. of control shaft	1 axis	
Positioning system	Key input (on front face)	
Positioning range	9999.9 mm	
Min. setting range	0.1 mm	
Memory system	Static RAM 8 K bite (Battery back up: life 5 years)	
Min. interval	5 mm or more	
Input signal	<ul style="list-style-type: none"> ● Start ● Hold ● Automatic/Manual ● Return to origin ● Emergency stop ● Manual: extended, retracted (2 bit) ● Program selection (4 bit) ● Input origin ● Reset 	
Output signal	<ul style="list-style-type: none"> ● Completion of positioning signal ● Program END signal ● Completion to figure out origin signal ● Abnormal signal 	
Control output	NPN open collector (30 VDC, 50 mA)	PNP open collector (30 VDC, 50 mA)
Counting speed	20 kHz (kcps)	
Power supply	90 to 110 VAC, 50/60 Hz and 21.6 to 26.4 VDC, 0.4 A	
Operating temperature range	0 to 50°C (No freezing)	
Humidity range	25 to 85% (No condensation)	
Shock resistance	Endurance 10 to 55 Hz, Amplitude 0.75 mm, X, Y, Z for 2 hours each	
Noise resistance	Square wave noise from a noise simulator (Pulse duration 1 μs) Between 100 VAC line ±1500 V, I/O line ±600 V	
Impact resistance	Endurance 10 G; X, Y, Z directions, 3 times each	
Withstand voltage	Between case and AC line: 1500 VAC for 1 min. (3 mA or less) Between case and 12 VDC line: 500 VAC for 1 min. (3 mA or less)	
Power consumption	100 VA or less	
Insulation resistance	Between case and AC line: 50 MΩ or more (500 VDC measured via megohmmeter)	
Weight	690 g	

* Refer to operation manual of CEU2 regarding detailed positioning system.

Dimensions

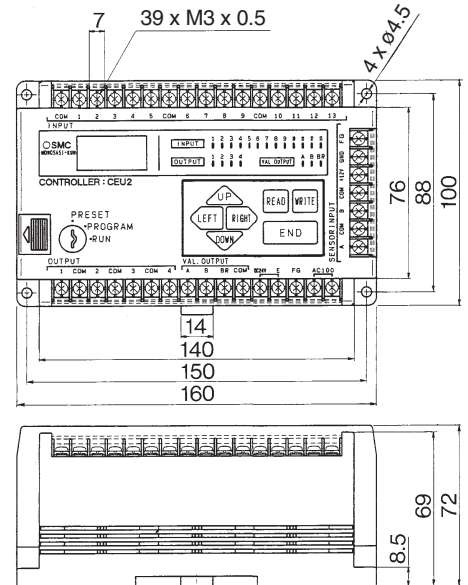

As for 3 point preset counter and multi counter, it will be common to CEP1 and CE1 series. For details, refer to 3 point preset counter/CEU1 on page 1618, and Multi counter/CEU5 on page 1615 respectively.

Wiring with External Equipment

<Wiring with controller CEU2>

1. Wiring of driving power of controller

To operate the controller, use a power supply with the following specifications: 90 to 110 VAC, 50/60 Hz, and 21.6 to 26.4 VDC, 0.4 A or higher.

3. Output circuit

There are two outputs, the NPN open collector and the PNP open collector. The maximum rating is 30 VDC, 50 mA. Operating the controller by exceeding this voltage and amperage could damage the electric circuit. Therefore, the equipment to be connected must be below this rating.

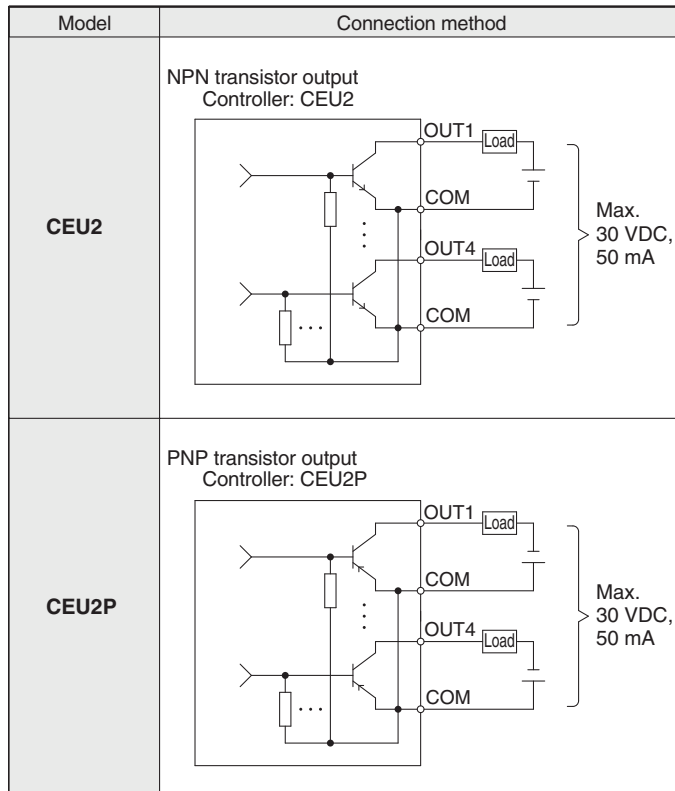

* However, on the valve output side, the COM of the input circuit and the COM of the output circuit are electrically insulated from each other.

2. Input circuit

The voltage and the amperage capacity of the switch or the PLC to be connected are 24 VDC, 10 mA or higher.

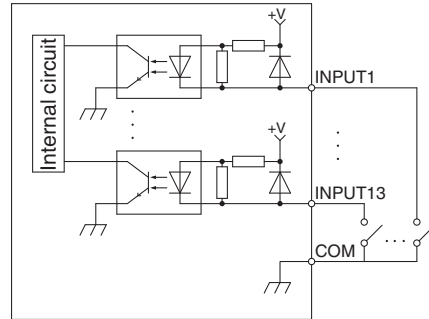

4. Valve output circuit

The maximum rating is 24 VDC, 80 mA. Operating the controller by exceeding this voltage and amperage could damage the electric circuit. Therefore, the equipment to be connected must be below this rating.

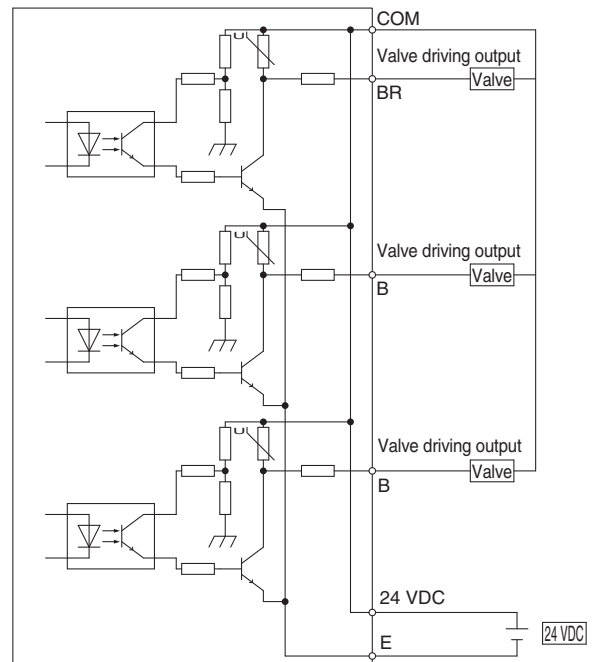

CEP1

CE1

CE2

ML2B

Electrical Wiring

<Output system of positioning detection sensor>

The position detection sensor of the stroke reading cylinder outputs an A/B phase difference (open collector output) as shown in the diagram below.

The relation between the moving distance and the output signal of the stroke reading cylinder with brake is as follows: Every 0.1 mm of movement of the stroke reading cylinder with brake outputs 1 pulse signal to both output terminals A and B.

The maximum response speed of the sensor for the stroke reading cylinder with brake is at a maximum cylinder speed of 1500 mm/s (15 kcps).

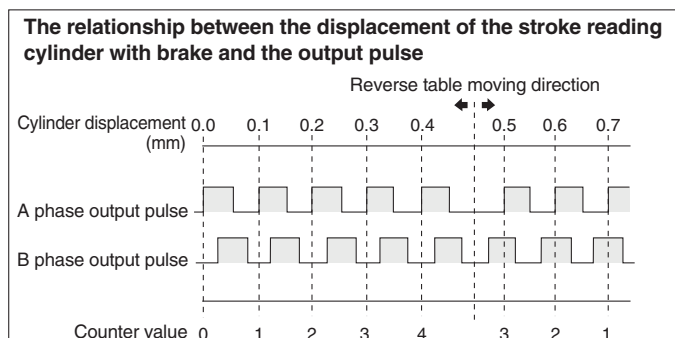

<Input, Output>

The connection of the input/output signals of the position detection sensor of the stroke reading cylinder is effected through the connector that extends from the cylinder. The output circuit and the connection of the connectors are described in the diagram below.

Output circuit of stroke reading cylinder with brake

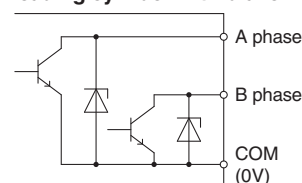

Connector pin arrangement

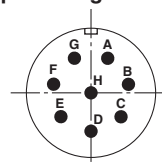

Signal

Contact signal	Wire color	Signal name
A	White	A phase
B	Yellow	B phase
C	Brown	COM (0 V)
D	Blue	COM (0 V)
E	Red	+12 V to 24 V
F	Black	0 V
G	—	Shield

D-□

-X□