

Residual Pressure Relief 3 Port Hand Valve **VHS400/500**

The VHS series is a safety manual switching valve for preventing accidents that can be caused by the residual pressure while performing maintenance service on a pneumatic system.

Easy to Operate

The direction of air flow can be verified at a glance by the orientation of the handle.

The valve is compact, yet provides a large capacity.



Symbol

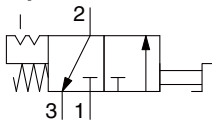

Specifications

Piping direction	Left 1(P)*	VHS400-02	VHS400-03	VHS400-04	VHS500-06
	Right 1(P)*	VHS401-02	VHS401-03	VHS401-04	VHS501-06
Port size		1/4	3/8	1/2	3/4
Cv factor	IN→OUT	1.24	2.06	3.35	5.47
	OUT→EXH	2.06	3.18	4.47	6.18
Fluid	Air				
Proof pressure	1.5 MPa				
Operating pressure	0.1 to 1.0 MPa				
Ambient temperature and operating fluid temperature	-5 to 60°C (No freezing)				
Handle switching angle	90°				
Required switching force	73.6 N (at 1.0 MPa)				
Paint color (Standard) Note)	Handle: Black, Body: Platinum silver				
Weight kg		0.25			0.34

* The front face of the handle is the reference position.
Note) Handle: Silver, Body: Red (Made to order "-X1")

How to Order

VHS 4 0 0 - 02 -

Residual relief 3 port valve

Body size

4	1/2
5	3/4

Piping direction

0	Left 1(P)
1	Right 1(P)

Thread type

Nil	Rc
N	NPT
F*	G

Option color

Nil	Standard color
X1	Handle: Silver, Body: Red
X116	Handle: Red

Port size

02	1/4	VHS40□
03	3/8	
04	1/2	VHS50□
06	3/4	

* Applicable port size: 1/4, 3/8

* When using the valve, please refer to the table of applicable effective areas for the respective exhaust ports.

Construction

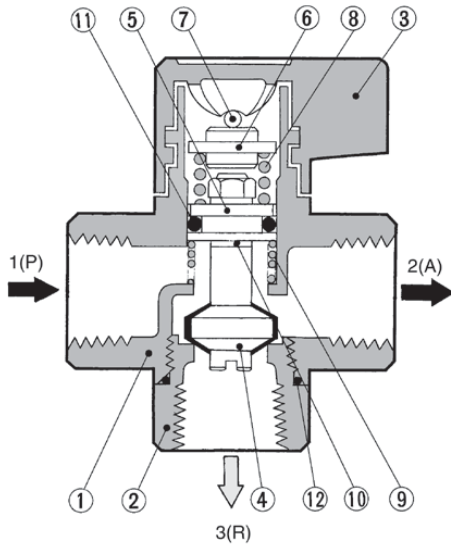

Component Parts

No.	Description	Material	Note
1	Body	Aluminium die-casted	Chromated
2	Valve guide	Zinc die-casted	Chromated
3	Handle	Zinc alloy	Chromated
4	Valve	Brass	
5	Piston	Brass	
6	Spring holder	Structural steel	
7	Parallel pin	Steel	Zinc chromated
8	Spring	Steel	Zinc chromated
9	Valve spring	Stainless steel	
10	Seal	PVC	
11	O-ring	NBR	JIS B 2401 P12.5
12	O-ring	NBR	Special

* The VHS series cannot be disassembled.
Components parts are not available.

Dimensions

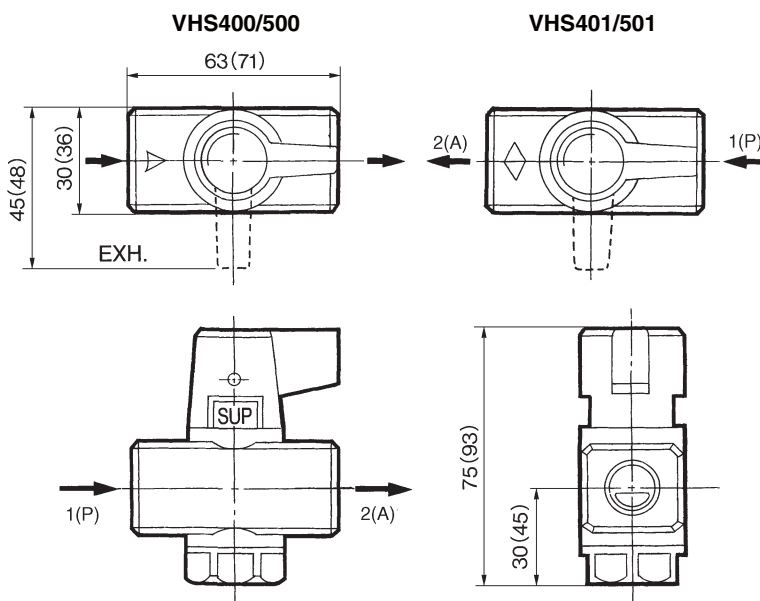

(): VHS500

⚠ Precautions

- Be sure to read this before handling the products.
- Refer to back page 50 for Safety Instructions and pages 3 to 9 for 3/4/5 Port Solenoid Valve Precautions.

Design

⚠ Warning

- When connecting the exhaust piping onto 3(R) port, confirm that the effective area is larger than the figure shown below. If the effective area is smaller than the figure listed below, back pressure will induce air leakage.

Model	Effective area (mm ²)
VHS400/401	5
VHS500/501	8

- Do not supply air pressure from ports other than 1(P) port. The valve will malfunction when air pressure is supplied from other ports.
- Do not use the valve under negative pressure. Air leakage may cause malfunction.

Selection

⚠ Caution

- The valve must be switched to each position instantly and securely. Stopping the handle between the extreme positions may cause malfunction.
- Do not remove the mounting screws from the handle as this may cause malfunction.

Piping

⚠ Warning

- The port marked with an arrow is 1(P) port (IN) and one on the opposite side is 2(A) port (OUT). The port at a right angle to them is 3(R) port (EXH). Be sure to confirm before connecting since erroneous connection will cause malfunction.
- When the valve is exposed to a large amount of dust and debris, install a silencer on 3(R) port (EXH) to protect the valve. Otherwise, dust will ingress from 3(R) port and cause air leakage. When dust enters the valve from the port "3(R)", it may cause malfunction.

Air Supply

⚠ Caution

- Install an air filter on the inlet side in proximity to the valve.
Filtration degree should be 5 μm or less.

VM

VMG

VR

VR51

VHK

VH

VHS□

VHS