



Compact Cylinder Series CQ2

ø12, ø16, ø20, ø25, ø32, ø40, ø50, ø63, ø80, ø100, ø125, ø140, ø160, ø180, ø200

With a short overall length, the space-saving cylinder helps to make various jigs and equipment more compact.

Series Variations

Series	Action	Rod	Basic	Built-in magnet	Mounting female thread (A)	Rod end male thread	With rubber bumper	With boss in head side	Bore size (mm)	Standard stroke (mm)	Page
Standard 	Double acting	Single rod CQ2	•	•	•	•	•	•	12, 16, 20, 25 32, 40, 50, 63 80, 100	ø12, ø16/5 to 30 ø20, ø25/5 to 50 ø32, ø40/5 to 100 ø50 to ø100/10 to 100	7-6-2
		Double rod CQ2W	•	•	•	•	•	•	•	12, 16, 20, 25 32, 40, 50, 63 80, 100	ø12, ø16/5 to 30 ø20, ø40/5 to 50 ø32, ø40/5 to 100 ø50 to ø100/10 to 100
	Single acting	Spring return/ Spring extend CQ2	•	•	•	•	•	•	•	12, 16, 20 25, 32, 40 50	ø12 to ø40/5, 10 ø50/10, 20
Non-rotating Rod 	Double acting	Single rod CQ2K	•	•	•	•	•	•	12, 16, 20 25, 32, 40 50, 63	ø12, ø16/5 to 30 ø20, ø25/5 to 50 ø32, ø40/5 to 100 ø50, ø63/10 to 100	7-6-62
		Double rod CQ2KW	•	•	•	•	•	•	•	12, 16, 20 25, 32, 40 50, 63	ø12, ø16/5 to 30 ø20, ø40/5 to 50 ø50, ø63/10 to 50
Axial Piping (Centralized Piping Type) 	Double acting	Single rod CQP2	•	•	•	•	•	•	12, 16, 20, 25 32, 40, 50, 63, 80, 100	ø12, ø16/5 to 30 ø20, ø25/5 to 50 ø32, ø40/5 to 100 ø50 to ø100/10 to 100	7-6-88
	Single acting	Spring return/ Spring extend CQP2	•	•	•	•	•	•	•	12, 16, 20 25, 32, 40 50	ø12 to ø40/5, 10 ø50/10, 20
Large Bore Size 	Double acting	Single rod CQ2	•	•	•	•	•	•	125, 140 160, 180 200	10 to 300	7-6-108
		Double rod CQ2W	•	•	•	•	•	•	•	125, 140 160, 180 200	10 to 300
Long Stroke 	Double acting	Single rod CQ2	•	•	•	•	•	•	32, 40, 50 63, 80, 100	125 to 300	7-6-121
Anti-lateral Load 	Double acting	Single rod CQ2□S	•	•	•	•	•	•	32, 40, 50 63, 80, 100	ø32 to ø40/5 to 100 ø50 to ø100/10 to 100	7-6-132
With End Lock 	Double acting	Single rod CBQ2	•	•	•	•	•	•	20, 25, 32 50, 63, 80 100	ø20 to ø63/10 to 100 ø80, ø100/25 to 100	7-6-142

Built-in One-touch fittings (Bore size ø32 to ø63)
Foot/Flange style
Double clevis style
Copper-free
Air-Hydro (Bore size ø20 to ø100)
Clean Series (Bore size ø12 to ø63)

CUJ
CU
CQS
CQM
CQ2
RQ
MU
D-
-X
20-
Data

Compact Cylinder: Standard Type Double Acting, Single Rod Series CQ2

ø12, ø16, ø20, ø25, ø32, ø40, ø50, ø63, ø80, ø100

How to Order

Without auto switch

CQ2 [B] [] [20] [] [30] [D] []

With auto switch

CDQ2 [B] [] [20] [] [30] [D] [] [J79W] [S]

Built-in magnet

Mounting style

B	Through-hole (Standard)	F	Rod side flange style
A	Both ends tapped style	G	Head side flange style
L	Foot style	D	Double clevis style

* Mounting brackets are shipped together, (but not assembled).

Type

Nil	Pneumatic
H	Air-hydro ^{Note)}

Note) Bore sizes available for air-hydro type are ø20 to ø100.

Bore size

12	12 mm	40	40 mm
16	16 mm	50	50 mm
20	20 mm	63	63 mm
25	25 mm	80	80 mm
32	32 mm	100	100 mm

Piping

Nil	Screw-in piping
F	Built-in One-touch fittings ^{Note)}

Note) Bore sizes available w/ One-touch fittings are ø32 to ø63. Besides, it is not possible to use for air-hydro type.

Auto switch

Nil	Without auto switch (Built-in magnet)
------------	---------------------------------------

* For the applicable auto switch model, refer to the table below.

Number of auto switches

Nil	2 pcs.
S	1 pc.
n	"n" pcs.

Body option

Nil	Standard (Rod end female thread)
F	With boss in head side
C	With rubber bumper
M	Rod end male thread ^{Note)}

* Combination of body options ("CM", "FC", "FM", "FCM") is available. Note) Air-hydro type with rubber bumper is not available.

Action

D	Double acting
----------	---------------

Cylinder stroke (mm)

For "Standard Stroke" and "Manufacture of intermediate of Stroke", refer to page 7-6-3.

Applicable Auto Switch/Refer to page 7-9-1 for further information on auto switches.

Type	Special function	Electrical entry	Indicator/light	Wiring (Output)	Load voltage		Rail mounting		Direct mounting		Lead wire length (m) *				Pre-wire connector	Applicable load			
					DC	AC	ø12 to ø100		ø32 to ø100		0.5 (Nil)	3 (L)	5 (Z)	None (N)		IC circuit	Relay, PLC		
							Perpendicular	In-line	Perpendicular	In-line									
Reed switch	—	Grommet	Yes	3-wire (NPN equivalent)	—	5V	—	A76H	A96V	A96	●	●	—	—	—	IC circuit	—		
				2-wire	—	200 V	A72	A72H	—	—	●	●	—	—	—	—	Relay, PLC		
		Connector		24 V	12 V	100 V	—	—	A93V	A93	●	●	—	—	—			—	Relay, PLC
					—	—	—	—	—	—	—	—	●	●	●	●	—		
Solid state switch	—	Grommet	Yes	3-wire (NPN)	5 V, 12 V	—	F7NV	F79	M9NV	M9N	●	●	○	—	○	IC circuit	Relay, PLC		
				3-wire (PNP)			F7PV	F7P	M9PV	M9P	●	●	○	—	○				
		Connector		12 V	2-wire	F7BV	J79	M9BV	M9B	●	●	○	—	○	—	—			
					3-wire (NPN)	F7NVV	F79W	F9NVV	F9NW	●	●	○	—	○	IC circuit				
		Grommet		24 V	12 V	3-wire (PNP)	F7BWW	J79W	F9BWW	F9BW	●	●	○	—	○	—		—	
						2-wire	—	F7BA	—	F9BA	—	●	○	—	○	—		—	
		Grommet		5 V, 12 V	—	4-wire (NPN)	—	F7BAV	—	—	—	—	●	○	—	—		IC circuit	
						2-wire	—	—	—	—	—	●	●	—	○	—		—	
		Grommet		5 V, 12 V	—	2-wire	—	—	—	—	—	—	●	●	—	○		—	IC circuit
							—	—	—	—	—	—	—	—	—	—		—	—

* Lead wire length symbols: 0.5 m Nil (Example) A73C
 3 m L (Example) A73CL
 5 m Z (Example) A73CZ
 None N (Example) A73CN

* Solid state switches marked with "○" are produced upon receipt of order.

- D-P5DWL type is available from ø40 up to ø100 only.
- There are other applicable auto switches other than the listed above. For details, refer to page 7-6-23.
- For details about auto switches with pre-wire connector, refer to page 7-9-36.

Compact Cylinder: Standard Type **Series CQ2**

Double Acting, Single Rod



JIS Symbol
Double acting,
Single rod

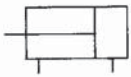

JIS Symbol
With boss in
head side

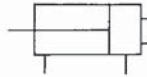

Standard Stroke

Pneumatic

Bore size (mm)	Standard stroke (mm)
12, 16	5, 10, 15, 20, 25, 30
20, 25	5, 10, 15, 20, 25, 30, 35, 40, 45, 50
32, 40	5, 10, 15, 20, 25, 30, 35, 40, 45, 50, 75, 100
50 to 100	10, 15, 20, 25, 30, 35, 40, 45, 50, 75, 100

• When stroke exceeds the standard range, refer to page 7-6-121.

Air-hydro

Bore size (mm)	Standard stroke (mm)
20, 25	5, 10, 15, 20, 25, 30, 35, 40, 45, 50
32, 40	5, 10, 15, 20, 25, 30, 35, 40, 45, 50, 75, 100
50, 63, 80, 100	10, 15, 20, 25, 30, 35, 40, 45, 50, 75, 100

Mounting Bracket Part No.

Bore size (mm)	Foot ⁽⁴⁾	Flange	Double clevis ⁽⁵⁾
12	CQ-L012	CQ-F012	CQ-D012
16	CQ-L016	CQ-F016	CQ-D016
20	CQ-L020	CQ-F020	CQ-D020
25	CQ-L025	CQ-F025	CQ-D025
32	CQ-L032	CQ-F032	CQ-D032
40	CQ-L040	CQ-F040	CQ-D040
50	CQ-L050	CQ-F050	CQ-D050
63	CQ-L063	CQ-F063	CQ-D063
80	CQ-L080	CQ-F080	CQ-D080
100	CQ-L100	CQ-F100	CQ-D100

Note 4) When ordering foot bracket, order 2 pieces per cylinder.

Note 5) Parts belonging to each bracket are as follows. Foot, Flange: Body mounting bolt/Double clevis: Clevis pin, Type C snap ring for axis, body mounting bolt

Type

Bore size (mm)		12	16	20	25	32	40	50	63	80	100	
Pneumatic	Mounting	Through-hole (Standard)	●	●	●	●	●	●	●	●	●	
		Both ends tapped style	●	●	●	●	●	●	●	●	●	●
	Built-in magnet		●	●	●	●	●	●	●	●	●	●
	Piping	Screw-in type	M5 x 0.8	M5 x 0.8	M5 x 0.8	M5 x 0.8	M5 x 0.8 ⁽¹⁾ Rc 1/8	Rc 1/8	Rc 1/4	Rc 1/4	Rc 3/8	Rc 3/8
		Built-in One-touch fittings	—	—	—	—	ø6/4 ⁽²⁾	ø6/4	ø8/6	ø8/6	—	—
	Rod end male thread		●	●	●	●	●	●	●	●	●	●
	With rubber bumper		●	●	●	●	●	●	●	●	●	●
	With boss in head side		●	●	●	●	●	●	●	●	●	●
	Air-hydro	Mounting	Through-hole (Standard)	—	—	●	●	●	●	●	●	●
			Both ends tapped style	—	—	●	●	●	●	●	●	●
Built-in magnet		—	—	●	●	●	●	●	●	●		
Piping		Screw-in type	—	—	M5 x 0.8	M5 x 0.8	M5 x 0.8 ⁽¹⁾ Rc 1/8	Rc 1/8	Rc 1/4	Rc 1/4	Rc 3/8	Rc 3/8
		Rod end male thread	—	—	●	●	●	●	●	●	●	●
With boss in head side		—	—	●	●	●	●	●	●	●	●	

Note 1) In the case of without auto switch, M5 x 0.8 is used for 5 stroke only.

Note 2) In the case of built-in fitting, the 5 mm stroke with ø32 bore is the same external dimensions as 10 mm stroke.

Specifications

Type	Pneumatic (Non-lube)	Air-hydro
Fluid	Air	Turbine oil ⁽³⁾
Proof pressure	1.5 MPa	
Maximum operating pressure	1.0 MPa	
Ambient and fluid temperature	Without auto switch: -10 to 70°C (No freezing) With auto switch: -10 to 60°C (No freezing)	
Rubber bumper	None	—
Rod end thread	Female thread	
Rod end thread tolerance	JIS class 2	
Stroke length tolerance	+1.0 0	
Mounting	Through-hole	
Piston speed	50 to 500 mm/s	5 to 50 mm/s

Note 3) For caution on handling, refer to page 7-13-6.

* For applications involving lateral loads, refer to anti-lateral load type on page 7-13-132.

Minimum Operating Pressure

Bore size (mm)	12	16	20	25	32	40	50	63	80	100
Pneumatic (Non-lube)	0.07		0.05							
Air-hydro	—		0.18			0.10				

Manufacture of Intermediate Stroke

Description	Spacer is installed in the standard stroke body.	Exclusive body (-XB10)
Part no.	Refer to "How to Order" for the standard model no. on page 7-6-2.	Suffix "-XB10" to the end of standard model no. on page 7-6-2.
Description	Dealing with intermediate stroke by the 1 mm interval is available by using spacer with standard stroke cylinder.	Dealing with the stroke by the 1 mm interval by using an exclusive body with the specified stroke.
Stroke range	Bore size	Bore size
	Stroke range	Stroke range
	Stroke range	Stroke range
Example	Part No.: CQ2B50-57D 18 mm width spacer is installed in the standard CQ2B50-75D. B dimension is 115.5 mm.	Part no. CQ2B50-57D-XB10 Makes 57 stroke tube. B dimension is 97.5 mm.



- Air-hydro type is excluded.
- In the case of spacer type, intermediate stroke with damper for ø40 to ø100, it can be manufactured by 5 mm intervals in 5 mm and 55 to 95 mm.
- In the case of an exclusive body with ø32 to ø100 (-XB10) with the stroke length exceeding 50 mm, the reference values of the longitudinal dimension will be changed. Calculate length dimensions by deducting from those of 75 or 100 mm stroke models.
- Regarding the long stroke which exceeds the stroke range, refer to page 7-6-121 for the long stroke type of either CQ2 or CQS.

CUJ

CU

CQS

CQM

CQ2

RQ

MU

D-

-X

20-

Data

Series CQ2



Made to Order Specifications (For details, refer to page 7-10-1.)

Symbol	Specifications
-XA□	Change of rod end shape
-XB6	Heat resistant cylinder (150°C) w/o auto switch only
-XB7	Cold resistant cylinder w/o auto switch only
-XB9	Low speed cylinder (10 to 50 mm/s)
-XB10	Intermediate stroke (Using exclusive body)
-XB11	Long stroke type, Air-hydro type only
-XB13	Low speed cylinder (5 to 50 mm/s)
-XB14	Cylinder with heat resistant auto switch ø16 to 63 only
-XB18	Low friction cylinder, ø32 to 100 only
-XC4	With heavy duty scraper, ø20 to 100 only
-XC6	Piston rod and rod end nut made of stainless steel
-XC8	Adjustable stroke cylinder/Adjustable extension type
-XC9	Adjustable stroke cylinder/Adjustable retraction type
-XC10	Dual stroke cylinder/Double rod type
-XC11	Dual stroke cylinder/Single rod type
-XC18	NPT finish piping port
-XC35	With coil scraper, ø32 to 100 only
-XC36	With boss in rod side
-XC58	Water resistance improved type/Built-in hard plastic magnet, ø20 to 100 only
-XC59	Fluoro rubber for seal/Built-in hard plastic magnet, ø20 to 100 only
-X202	Same overall length dimension as Series CQ1, Except ø16, 25
-X203	Same L dimension from rod cover as Series CQ1, ø20, 32 only
-X293	Same overall length as Series CQ1W, Except ø16, 25
-X144	Change of port location, ø12 to 25 only
-X271	Fluoro rubber for seals
-X525	Long stroke of adjustable extension stroke cylinder (-XC8)
-X526	Long stroke of adjustable retraction stroke cylinder (-XC9)
-X636	Intermediate stroke of double rod type

Series CQ2

Theoretical Output



Bore size (mm)	Operating direction	Operating pressure (MPa)		
		0.3	0.5	0.7
12	IN	25	42	59
	OUT	34	57	79
16	IN	45	75	106
	OUT	60	101	141
20	IN	71	118	165
	OUT	94	157	220
25	IN	113	189	264
	OUT	147	245	344
32	IN	181	302	422
	OUT	241	402	563
40	IN	317	528	739
	OUT	377	628	880
50	IN	495	825	1150
	OUT	589	982	1370
63	IN	841	1400	1960
	OUT	935	1560	2180
80	IN	1360	2270	3170
	OUT	1510	2510	3520
100	IN	2140	3570	5000
	OUT	2360	3930	5500

Mounting Bolt for CQ2

Mounting method: Mounting bolt for through-hole mounting style of CQ2B is available as an option.

Ordering: Add the word "Bolt" in front of the bolts to be used.

Example) Bolt M3 x 25 ℓ 4 pcs.

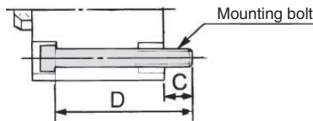

Model	C	D	Mounting bolt
CQ2B12-5D	6.5	25	M3 x 25 ℓ
-10D		30	x 30 ℓ
-15D		35	x 35 ℓ
-20D		40	x 40 ℓ
-25D		45	x 45 ℓ
-30D	50	x 50 ℓ	
CQ2B16-5D	5	25	M3 x 25 ℓ
-10D		30	x 30 ℓ
-15D		35	x 35 ℓ
-20D		40	x 40 ℓ
-25D		45	x 45 ℓ
-30D	50	x 50 ℓ	
CQ2B20-5D	7.5	25	M5 x 25 ℓ
-10D		30	x 30 ℓ
-15D		35	x 35 ℓ
-20D		40	x 40 ℓ
-25D		45	x 45 ℓ
-30D		50	x 50 ℓ
-35D		55	x 55 ℓ
-40D	60	x 60 ℓ	
-45D	65	x 65 ℓ	
-50D	70	x 70 ℓ	
CQ2B25-5D	9.5	30	M5 x 30 ℓ
-10D		35	x 35 ℓ
-15D		40	x 40 ℓ
-20D		45	x 45 ℓ
-25D		50	x 50 ℓ
-30D		55	x 55 ℓ
-35D		60	x 60 ℓ
-40D		65	x 65 ℓ
-45D		70	x 70 ℓ
-50D	75	x 75 ℓ	

Model	C	D	Mounting bolt
CQ2B32-5D	9	30	M5 x 30 ℓ
-10D		35	x 35 ℓ
-15D		40	x 40 ℓ
-20D		45	x 45 ℓ
-25D		50	x 50 ℓ
-30D		55	x 55 ℓ
-35D		60	x 60 ℓ
-40D		65	x 65 ℓ
-45D		70	x 70 ℓ
-50D		75	x 75 ℓ
-75D	110	x 110 ℓ	
-100D	135	x 135 ℓ	
CQ2B40-5D	7.5	35	M5 x 35 ℓ
-10D		40	x 40 ℓ
-15D		45	x 45 ℓ
-20D		50	x 50 ℓ
-25D		55	x 55 ℓ
-30D		60	x 60 ℓ
-35D		65	x 65 ℓ
-40D		70	x 70 ℓ
-45D		75	x 75 ℓ
-50D		80	x 80 ℓ
-75D	115	x 115 ℓ	
-100D	140	x 140 ℓ	
CQ2B50-10D	12.5	45	M6 x 45 ℓ
-15D		50	x 50 ℓ
-20D		55	x 55 ℓ
-25D		60	x 60 ℓ
-30D		65	x 65 ℓ
-35D		70	x 70 ℓ
-40D		75	x 75 ℓ
-45D		80	x 80 ℓ
-50D		85	x 85 ℓ
-75D		120	x 120 ℓ
-100D	145	x 145 ℓ	

Model	C	D	Mounting bolt
CQ2B63-10D	14.5	50	M8 x 50 ℓ
-15D		55	x 55 ℓ
-20D		60	x 60 ℓ
-25D		65	x 65 ℓ
-30D		70	x 70 ℓ
-35D		75	x 75 ℓ
-40D		80	x 80 ℓ
-45D		85	x 85 ℓ
-50D		90	x 90 ℓ
-75D		125	x 125 ℓ
-100D	150	x 150 ℓ	
CQ2B80-10D	15	55	M10 x 55 ℓ
-15D		60	x 60 ℓ
-20D		65	x 65 ℓ
-25D		70	x 70 ℓ
-30D		75	x 75 ℓ
-35D		80	x 80 ℓ
-40D		85	x 85 ℓ
-45D		90	x 90 ℓ
-50D		95	x 95 ℓ
-75D		130	x 130 ℓ
-100D	155	x 155 ℓ	
CQ2B100-10D	15.5	65	M10 x 65 ℓ
-15D		70	x 70 ℓ
-20D		75	x 75 ℓ
-25D		80	x 80 ℓ
-30D		85	x 85 ℓ
-35D		90	x 90 ℓ
-40D		95	x 95 ℓ
-45D		100	x 100 ℓ
-50D		105	x 105 ℓ
-75D		140	x 140 ℓ
-100D	165	x 165 ℓ	

Weight

(g)

Bore size (mm)	Cylinder stroke (mm)											
	5	10	15	20	25	30	35	40	45	50	75	100
12	29	35	41	47	54	60	—	—	—	—	—	—
16	42	50	59	67	76	84	—	—	—	—	—	—
20	63	75	88	101	114	127	140	152	165	178	—	—
25	86	100	115	129	144	158	173	187	202	216	—	—
32	131	152	173	193	214	235	256	277	297	318	471	576
40	206	229	252	275	298	321	344	367	390	413	597	717
50	—	369	405	441	477	514	550	586	622	659	951	1139
63	—	538	579	620	661	702	742	783	824	865	1213	1424
80	—	997	1064	1132	1200	1268	1336	1404	1471	1539	2111	2446
100	—	1738	1829	1920	2011	2101	2192	2283	2374	2464	3269	3729

Additional Weight

(g)

Bore size (mm)	12	16	20	25	32	40	50	63	80	100
Both ends tapped style	2	2	6	6	6	6	6	19	45	45
Rod end male thread	Thread	1.5	3	6	12	26	27	53	53	120
	Nut	1	2	4	8	17	17	32	32	49
With boss in head side	0.7	1.3	2	3	5	7	13	25	45	96
With rubber bumper	0	0	-2	-3	-3	-7	-9	-18	-31	-56
Built-in One-touch fittings	—	—	—	—	12	12	21	21	—	—
Foot style (Including mounting bolt)	55	67	164	186	143	155	243	324	696	1062
Rod side flange style (Including mounting bolt)	57	69	139	161	180	214	373	559	1056	1365
Rear flange style (Including mounting bolt)	54	65	133	152	165	198	348	534	1017	1309
Double clevis style (Including pin, snap ring, bolt)	32	39	88	123	151	196	393	554	1109	1887

Calculation: (Example) CQ2D32-20DCM

- Cylinder weight: CQ2B32-20D 193 g
 - Option weight: Both ends tapped style 6 g
 - Rod end male thread 43 g
 - Rubber bumper 3 g
 - Double clevis style 151 g
- 390 g

Construction

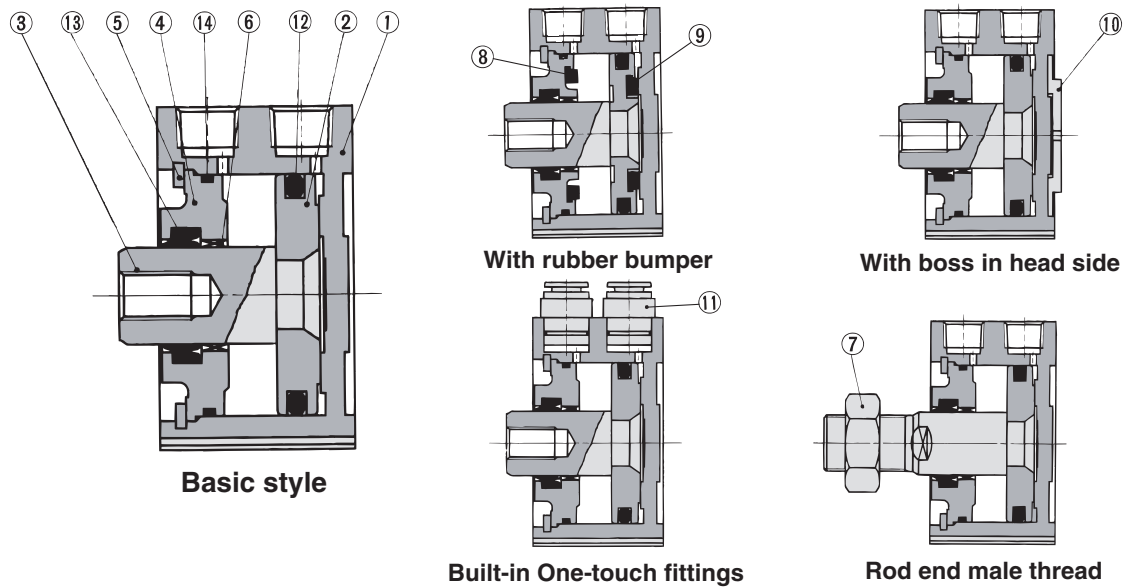

Component Parts

No.	Description	Material	Note
①	Cylinder tube	Aluminum alloy	Hard anodized
②	Piston *	Aluminum alloy	Chromated
③	Piston rod *	Stainless steel	ø12 to ø25
		Carbon steel	ø32 to ø100, Hard chrome plated
④	Collar	Aluminum alloy	ø12 to ø40, Anodized
		Aluminum alloy casted	ø50 to ø100, Chromated, painted
⑤	Snap ring	Carbon tool steel	Phosphate coated
⑥	Bushing	Lead-bronze casted	For ø50 or larger only
⑦	Rod end nut	Carbon steel	Nickel plated
⑧	Bumper A	Urethane	

No.	Description	Material	Note
⑨	Bumper B	Resin	
⑩	Centering location ring	Aluminum alloy	Hard anodized ø20 to ø100
⑪	One-touch fitting	—	ø32 to ø63
⑫	Piston seal	NBR	
⑬	Rod seal	NBR	
⑭	Gasket	NBR	

* On bore size ø12 to ø25 with rubber bumper style, piston and piston rod are integrated (Stainless steel).

Replacement Parts: Seal Kit

Series	Bore size (mm)	Kit no.	Contents
Pneumatic	12	CQ2B12-PS	Set of nos. above ⑫, ⑬, ⑭
	16	CQ2B16-PS	
	20	CQ2B20-PS	
	25	CQ2B25-PS	
	32	CQ2B32-PS	
	40	CQ2B40-PS	
	50	CQ2B50-PS	
	63	CQ2B63-PS	
	80	CQ2B80-PS	
	100	CQ2B100-PS	

Series	Bore size (mm)	Kit no.	Contents
Air-hydro	20	CQ2BH20-PS	Set of nos. above ⑫, ⑬, ⑭
	25	CQ2BH25-PS	
	32	CQ2BH32-PS	
	40	CQ2BH40-PS	
	50	CQ2BH50-PS	
	63	CQ2BH63-PS	
	80	CQ2BH80-PS	
	100	CQ2BH100-PS	

* Seal kit includes ⑫ ⑬ ⑭ Order the seal kit, based on each bore size.

Auto Switch Mounting Bracket Part No.

Bore size (mm)	Mounting bracket part no.	Note	Applicable auto switch	
			Reed switch	Solid state switch
12, 16 20, 25	BQ-1	<ul style="list-style-type: none"> Switch mounting screw (M3 x 0.5 x 8ℓ) Square nut 	D-A7□/A80 D-A73C/A80C D-A7□H/A80H D-A79W	D-F7□/J79 D-F7□V D-J79C D-F7□W/J79W D-F7□WV D-F7BAL/F7BAVL D-F79F D-F7NTL
32, 40 50, 63 80, 100	BQ-2	<ul style="list-style-type: none"> Switch mounting screw (M3 x 0.5 x 10ℓ) Switch spacer Switch mounting nut 		
40 to 100	BQP1-050	<ul style="list-style-type: none"> Switch mounting bracket Switch mounting nut Hexagon hole cap bolt (M3 x 0.5 x 14ℓ spring washer 2 pcs.) Round head Phillips screw (M3 x 0.5 x 16ℓ springwasher 2 pcs.) 	—	D-P5DWL

[Mounting screws set made of stainless steel]

The set of stainless steel mounting screws (with nuts) described below is available and can be used depending on the operating environment.

(Since the spacer is not included, order it separately.)
BBA2: For D-A7/A8/F7/J7

D-F7BAL/F7BAVL switch is set on the cylinder with the stainless steel screws above when shipped.

When only a switch is shipped independently, BBA2 screws are attached.

Series CQ2

Clean Series



The type which is applicable for using inside the clean room graded Class 100 by making an actuator's rod section a double seal construction and discharging by relief port directly to the outside of clean room.



Specifications

Action	Double acting, Single rod
Bore size (mm)	12, 16, 20, 25, 32, 40, 50, 63
Proof pressure	1.5 MPa
Maximum operating pressure	1.0 MPa
Rubber bumper	None ^{Note)}
Piping	Screw-in piping
Piston speed	50 to 500 mm/s
Mounting	Through-hole
Auto switch	Mountable

Note) $\phi 12$ with switch: With rubber bumper (Standard)

For details, refer to the separate catalog, "Pneumatic Clean Series".

Copper-free (For CRT manufacturing process)



To prevent the influence of copper ions or halogen ions during CRT manufacturing processes, copper and fluorine materials are not used in the component parts.



Specifications

Action	Double acting, Single rod
Bore size (mm)	12, 16, 20, 25, 32, 40, 50, 63, 80, 100
Proof pressure	1.5 MPa
Maximum operating pressure	1.0 MPa
Rubber bumper	With, None
Piping	Screw-in piping
Piston speed	50 to 500 mm/s
Mounting	Both ends tapped style
Auto switch	Mountable

Construction

Series 10-CQ2 (Double seal type)

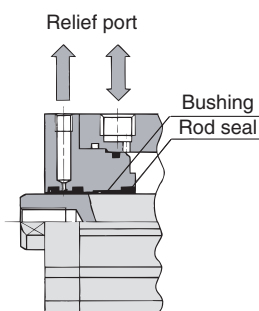

A relief port is provided in the area between the double rod seals to discharge the exhaust air outside of the clean room. Thus, the amount of dust generated has been reduced to 1/20 of that of an ordinary cylinder.

Series 11-CQ2 (Single seal, Vacuum suction)

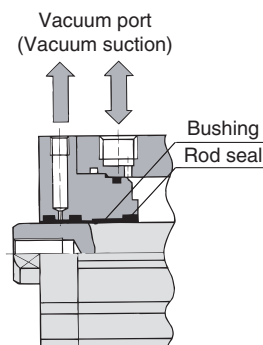

Structurally identical to the "10-" series, the outer rod seal has been removed to evacuate through the vacuum port. This draws out any external air from the clearance between the rod and the cover to practically eliminate the generation of external dust. This should be used in an application that requires an even higher level of cleanliness than the 10- series.

Water Resistant

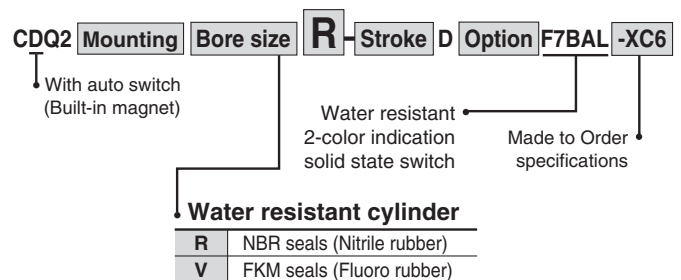

Ideal for use under the atmosphere having coolant for machine tools, etc. Compatible for the environment, where waterdrops are splashed around the food processing machinery and the car washers, etc.



Specifications

Action	Double acting, Single rod
Bore size (mm)	20, 25, 32, 40, 50, 63, 80, 100
Cushion	None
Auto switch mounting	Rail mounting (D-F7BAL)
Made to order	Piston rod/Rod end nut material: Stainless steel (-XC6)

* Specifications other than above are the same as standard, basic style.

For detailed specifications, refer to the separate catalog.

Compact Cylinder Series CDQ2 With Auto Switch



* Refer to page 7-9-1 for further information on auto switches.

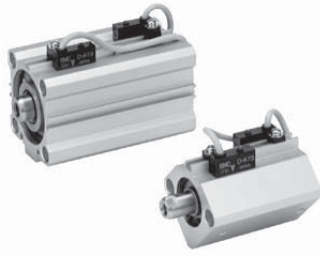

Minimum Stroke for Auto Switch Mounting

(mm)

No. of auto switches mounted	D-F7□V D-J79C D-F9□V	D-A7□ D-A80 D-A73C D-A80C D-A9□V	D-F7□WV D-F9□WV D-F7BAVL	D-A7□H D-A80H D-F7□ D-J79 D-M9□ D-F9□W	D-A79W	D-F7□W D-J79W D-F7BAL D-F79F D-F9BAL	D-A9□	D-P5DWL
1 pc.	5	5	10	15	15	20	10	30
2 pcs.	5	10	15	15	20	20	10	30

Weight

(g)

Bore size (mm)	Cylinder stroke (mm)											
	5	10	15	20	25	30	35	40	45	50	75	100
12	47	54	60	67	74	80	—	—	—	—	—	—
16	73	82	92	101	110	119	—	—	—	—	—	—
20	109	122	136	150	164	178	191	205	219	233	—	—
25	144	161	178	195	211	228	245	262	278	295	—	—
32	190	211	232	252	273	294	315	335	356	377	482	587
40	282	305	328	351	375	398	421	444	467	490	610	730
50	—	487	523	559	595	632	668	704	740	777	965	1153
63	—	696	737	778	819	860	901	941	982	1023	1235	1446
80	—	1258	1325	1393	1461	1529	1597	1665	1732	1800	2135	2469
100	—	2118	2209	2299	2390	2481	2572	2662	2753	2844	3304	3764

Additional Weight

(g)

Bore size (mm)	12	16	20	25	32	40	50	63	80	100	
Both ends tapped style	1	1	3	3	6	6	6	19	45	45	
Rod end male thread	Male thread	1.5	3	6	12	26	27	53	53	120	175
	Nut	1	2	4	8	17	17	32	32	49	116
With boss in head side	0.7	1.3	2	3	5	7	13	25	45	96	
With rubber bumper	0	-1	-2	-3	-3	-7	-9	-18	-31	-56	
Built-in One-touch fittings	—	—	—	—	12	12	21	21	—	—	
Foot style (Including mounting bolt)	49	62	147	169	143	155	243	324	696	1062	
Rod side flange style (Including mounting bolt)	54	67	131	153	180	214	373	559	1056	1365	
Rear flange style (Including mounting bolt)	52	63	124	144	165	198	348	534	1017	1309	
Double clevis style (Including pin, snap ring, bolt)	29	35	78	114	151	196	393	554	1109	1887	

Calculation: (Example) CDQ2D32-20DCM

- Cylinder weight: CDQ2B32-20D.....252 g
 - Option weight: Both ends tapped style.....6 g
Rod end male thread.....43 g
Rubber bumper.....-3 g
Double clevis style.....151 g
- 449 g

Add each weight of auto switches and mounting brackets.

Auto Switch Mounting Bracket Weight

Mounting bracket part no.	Applicable bore (mm)	Weight (g)
BQ-1	12 to 25	1.5
BQ-2	32 to 100	1.5

For the auto switch weight, refer to page 7-9-1.

CUJ

CU

CQS

CQM

CQ2

RQ

MU

D-

-X

20-

Data

Series CDQ2

Construction

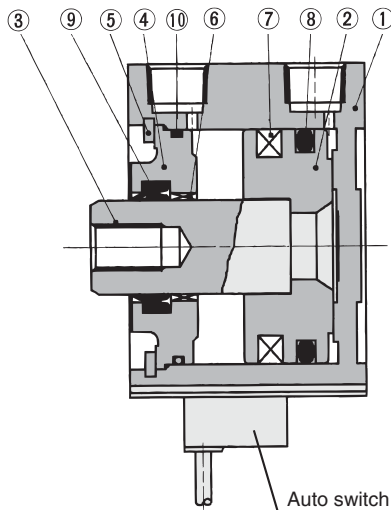

Component Parts

No.	Description	Material	Note
①	Cylinder tube	Aluminum alloy	Hard anodized
②	Piston	Aluminum alloy	Chromated
③	Piston rod	Stainless steel	ø12 to ø25
		Carbon steel	ø32 to ø100, Hard chrome plated
④	Collar	Aluminum alloy	ø12 to ø40, Anodized
		Aluminum alloy casted	ø50 to ø100, Chromated, painted
⑤	Snap ring	Carbon tool steel	Phosphate coated
⑥	Bushing	Lead-bronze casted	For ø50 or larger only
⑦	Magnet	—	
⑧	Piston seal	NBR	
⑨	Rod seal	NBR	
⑩	Gasket	NBR	

Replacement Parts: Seal Kit

Series	Bore size (mm)	Kit no.	Contents
Pneumatic	12	CQ2B12-PS	Set of nos. above ⑧, ⑨, ⑩.
	16	CQ2B16-PS	
	20	CQ2B20-PS	
	25	CQ2B25-PS	
	32	CQ2B32-PS	
	40	CQ2B40-PS	
	50	CQ2B50-PS	
	63	CQ2B63-PS	
	80	CQ2B80-PS	
100	CQ2B100-PS		

Replacement Parts: Seal Kit

Series	Bore size (mm)	Kit no.	Contents
Air-hydro	20	CQ2BH20-PS	Set of nos. above ⑧, ⑨, ⑩.
	25	CQ2BH25-PS	
	32	CQ2BH32-PS	
	40	CQ2BH40-PS	
	50	CQ2BH50-PS	
	63	CQ2BH63-PS	
	80	CQ2BH80-PS	
	100	CQ2BH100-PS	

* Seal kits includes ⑧ ⑨ ⑩. Order the seal kit, based on each bore size.

Mounting Bolt for CDQ2 with Auto Switch

Mounting method: Mounting bolt for through-hole mounting style of CDQ2B is available as an option.

Ordering: Add the word "Bolt" in front of the bolts to be used.

Example) Bolt M3 x 35ℓ 2 pcs.

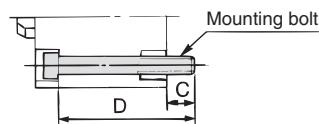

Model	C	D	Mounting bolt
CDQ2B12-5D	5.5	35	M3 x 35ℓ
-10D		40	x 40ℓ
-15D		45	x 45ℓ
-20D		50	x 50ℓ
-25D		55	x 55ℓ
-30D		65	x 60ℓ
CDQ2B16-5D	8	40	M3 x 40ℓ
-10D		45	x 45ℓ
-15D		50	x 50ℓ
-20D		55	x 55ℓ
-25D		60	x 60ℓ
-30D		65	x 65ℓ
CDQ2B20-5D	10.5	40	M5 x 40ℓ
-10D		45	x 45ℓ
-15D		50	x 50ℓ
-20D		55	x 55ℓ
-25D		60	x 60ℓ
-30D		65	x 65ℓ
-35D		70	x 70ℓ
-40D		75	x 75ℓ
-45D		80	x 80ℓ
-50D		85	x 85ℓ
CDQ2B25-5D	9.5	40	M5 x 40ℓ
-10D		45	x 45ℓ
-15D		50	x 50ℓ
-20D		55	x 55ℓ
-25D		60	x 60ℓ
-30D		65	x 65ℓ
-35D		70	x 70ℓ
-40D		75	x 75ℓ
-45D		80	x 80ℓ
-50D		85	x 85ℓ

Model	C	D	Mounting bolt
CDQ2B32-5D	9	40	M5 x 40ℓ
-10D		45	x 45ℓ
-15D		50	x 50ℓ
-20D		55	x 55ℓ
-25D		60	x 60ℓ
-30D		65	x 65ℓ
-35D		70	x 70ℓ
-40D		75	x 75ℓ
-45D		80	x 80ℓ
-50D		85	x 85ℓ
CDQ2B40-5D	7.5	45	M5 x 45ℓ
-10D		50	x 50ℓ
-15D		55	x 55ℓ
-20D		60	x 60ℓ
-25D		65	x 65ℓ
-30D		70	x 70ℓ
-35D		75	x 75ℓ
-40D		80	x 80ℓ
-45D		85	x 85ℓ
-50D		90	x 90ℓ
CDQ2B50-10D	12.5	55	M6 x 55ℓ
-15D		60	x 60ℓ
-20D		65	x 65ℓ
-25D		70	x 70ℓ
-30D		75	x 75ℓ
-35D		80	x 80ℓ
-40D		85	x 85ℓ
-45D		90	x 90ℓ
-50D		95	x 95ℓ
-75D		120	x 120ℓ
-100D	145	x 145ℓ	

Model	C	D	Mounting bolt
CDQ2B63-10D	14.5	60	M8 x 60ℓ
-15D		65	x 65ℓ
-20D		70	x 70ℓ
-25D		75	x 75ℓ
-30D		80	x 80ℓ
-35D		85	x 85ℓ
-40D		90	x 90ℓ
-45D		95	x 95ℓ
-50D		100	x 100ℓ
-75D		125	x 125ℓ
CDQ2B80-10D	15	65	M10 x 65ℓ
-15D		70	x 70ℓ
-20D		75	x 75ℓ
-25D		80	x 80ℓ
-30D		85	x 85ℓ
-35D		90	x 90ℓ
-40D		95	x 95ℓ
-45D		100	x 100ℓ
-50D		105	x 105ℓ
-75D		130	x 130ℓ
-100D	155	x 155ℓ	
CDQ2B100-10D	15.5	75	M10 x 75ℓ
-15D		80	x 80ℓ
-20D		85	x 85ℓ
-25D		90	x 90ℓ
-30D		95	x 95ℓ
-35D		100	x 100ℓ
-40D		105	x 105ℓ
-45D		110	x 110ℓ
-50D		115	x 115ℓ
-75D		140	x 140ℓ
-100D	165	x 165ℓ	

Series CQ2

Dimensions: $\phi 12$ to $\phi 25$

Basic style (Through-hole): CQ2B

Both ends tapped style: CQ2A

Both Ends Tapped Style

Bore size (mm)	O ₁	R
12	M4 x 0.7	7
16	M4 x 0.7	7
20	M6 x 1.0	10
25	M6 x 1.0	10

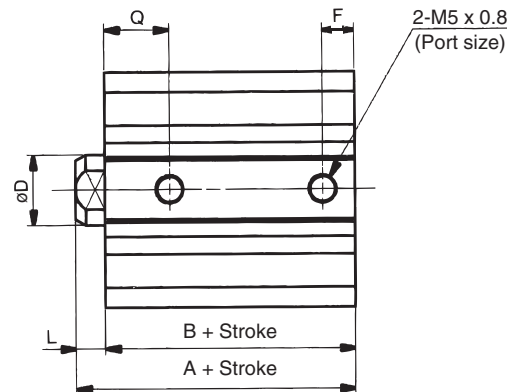
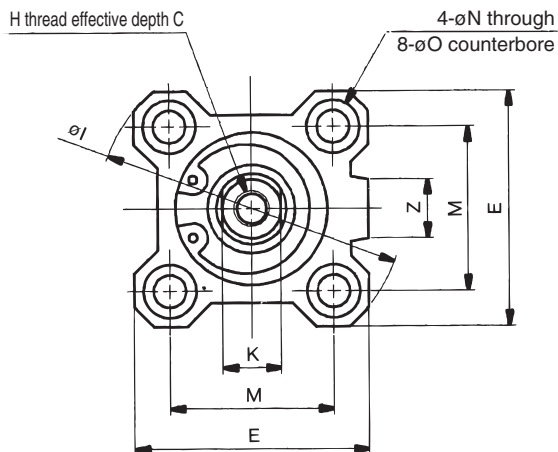
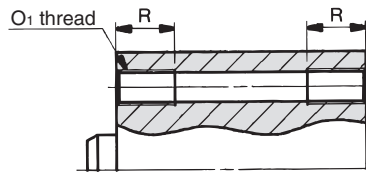

With boss in head side

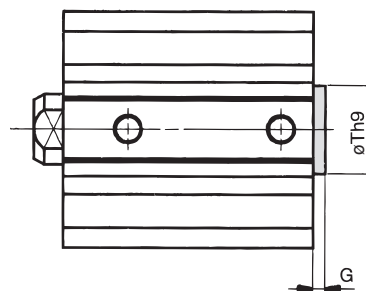

With Boss in Head Side

Bore size (mm)	G	Th9
12	1.5	15 ⁰ _{-0.043}
16	1.5	20 ⁰ _{-0.052}
20	2	13 ⁰ _{-0.043}
25	2	15 ⁰ _{-0.043}

Note) With boss in rod side:
Option
(Suffix "-XC36" to the end of part number.)

Rod end male thread

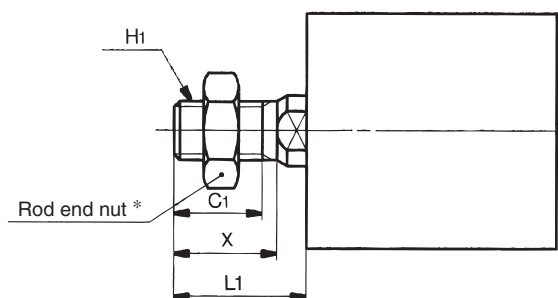

Rod End Male Thread

Bore size (mm)	C1	X	H1	L1
12	9	10.5	M5 x 0.8	14
16	10	12	M6 x 1.0	15.5
20	12	14	M8 x 1.25	18.5
25	15	17.5	M10 x 1.25	22.5

Basic Style

Bore size (mm)	Stroke range (mm)	A	B	C	D	E	F	H	I	K	L	M	N	O	Q	Z
12	5 to 30	20.5	17	6	6	25	5	M3 x 0.5	32	5	3.5	15.5	3.5	6.5 depth 3.5	7.5	—
16	5 to 30	22	18.5	8	8	29	5.5	M4 x 0.7	38	6	3.5	20	3.5	6.5 depth 3.5	8	10
20	5 to 50	24	19.5	7	10	36	5.5	M5 x 0.8	47	8	4.5	25.5	5.5	9 depth 7	9	10
25	5 to 50	27.5	22.5	12	12	40	5.5	M6 x 1.0	52	10	5	28	5.5	9 depth 7	11	10

Note) External dimensions with rubber bumper are same as standard type as shown above.

* For details about the rod end nut and accessory brackets, refer to page 7-6-20.

For calculation on the longitudinal dimension of the intermediate strokes, refer to page 7-6-3.

Compact Cylinder: Standard Type Double Acting, Single Rod Series CQ2

Foot style: CQ2L

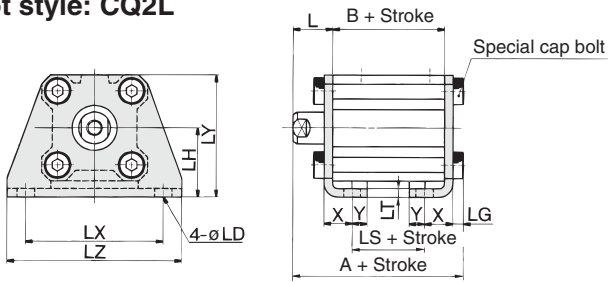

Rod end male thread

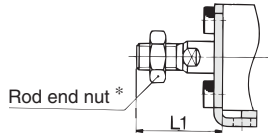

Rod side flange style: CQ2F

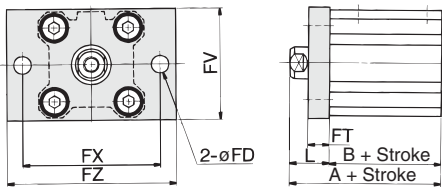

Rod end male thread

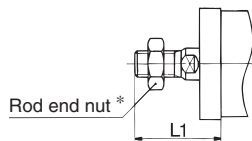

Head side flange style: CQ2G

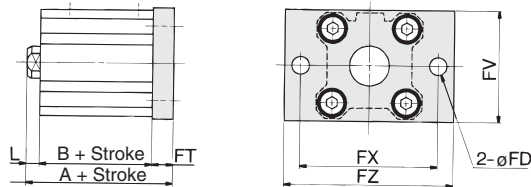

Rod end male thread

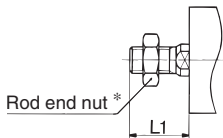

Double clevis style: CQ2D

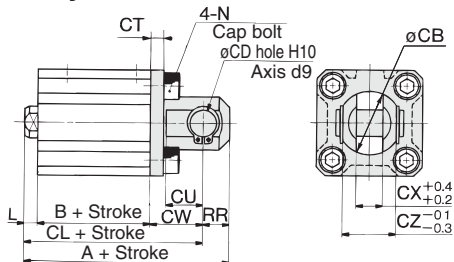

Rod end male thread

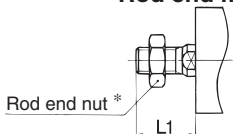

Foot Style

Bore size (mm)	Stroke range (mm)	A	B	L	L1	LD	LG	LH	LS	LT	LX	LY	LZ	X	Y
12	5 to 30	35.3	17	13.5	24	4.5	2.8	17	5	2	34	29.5	44	8	4.5
16	5 to 30	36.8	18.5	13.5	25.5	4.5	2.8	19	6.5	2	38	33.5	48	8	5
20	5 to 50	41.2	19.5	14.5	28.5	6.6	4	24	7.5	3.2	48	42	62	9.2	5.8
25	5 to 50	44.7	22.5	15	32.5	6.6	4	26	7.5	3.2	52	46	66	10.7	5.8

Foot bracket material: Carbon steel

Rod Side Flange Style

Bore size (mm)	Stroke range (mm)	A	B	FD	FT	FV	FX	FZ	L	L1
12	5 to 30	30.5	17	4.5	5.5	25	45	55	13.5	24
16	5 to 30	32	18.5	4.5	5.5	30	45	55	13.5	25.5
20	5 to 50	34	19.5	6.6	8	39	48	60	14.5	28.5
25	5 to 50	37.5	22.5	6.6	8	42	52	64	15	32.5

Flange bracket material: Carbon steel

Head Side Flange Style

Bore size (mm)	Stroke range (mm)	A	L	L1
12	5 to 30	26	3.5	14
16	5 to 30	27.5	3.5	15.5
20	5 to 50	32	4.5	18.5
25	5 to 50	35.5	5	22.5

(* Dimensions except A, L and L1 are the same as rod side flange style.)

Flange bracket material: Carbon steel

Double Clevis Style

Bore size (mm)	Stroke range (mm)	A	B	CB	CD	CL	CT	CU	CW	CX	CZ	L	L1	N	RR
12	5 to 30	40.5	17	12	5	34.5	4	7	14	5	10	3.5	14	M4 x 0.7	6
16	5 to 30	43	18.5	14	5	37	4	10	15	6.5	12	3.5	15.5	M4 x 0.7	6
20	5 to 50	51	19.5	20	8	42	5	12	18	8	16	4.5	18.5	M6 x 1.0	9
25	5 to 50	57.5	22.5	24	10	47.5	5	14	20	10	20	5	22.5	M6 x 1.0	10

Double clevis bracket material: Carbon steel

* For details about the rod end nut and accessory brackets, refer to page 7-6-20.
** Clevis pin and snap ring are shipped together.

CUJ

CU

CQS

CQM

CQ2

RQ

MU

D-

-X

20-

Data

Series CDQ2

Dimensions: $\phi 12$ to $\phi 25$ /With Auto Switch

Basic style (Through-hole): CDQ2B

Both ends tapped style: CDQ2A

Both Ends Tapped Style

Bore size (mm)	O ₁	R
12	M4 x 0.7	7
16	M4 x 0.7	7
20	M6 x 1.0	10
25	M6 x 1.0	10

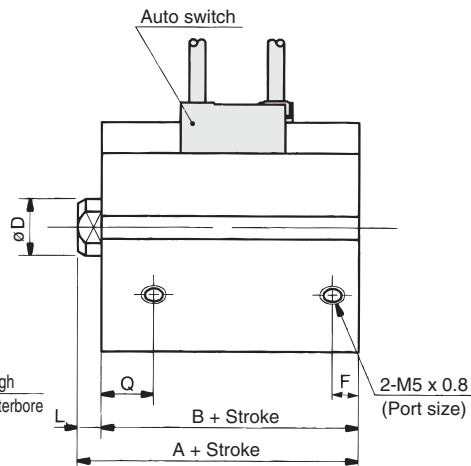
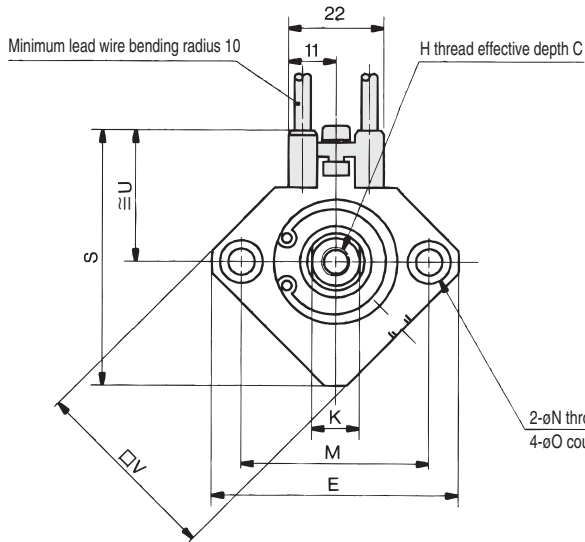
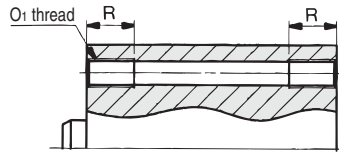

With boss in head side

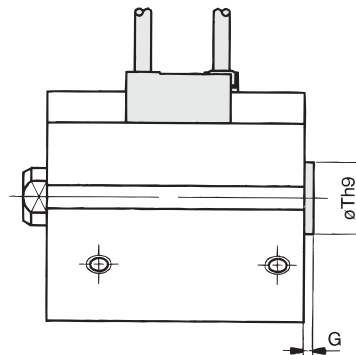

With Boss in Head Side

Bore size (mm)	G	Th9
12	1.5	15 ⁰ _{-0.043}
16	1.5	20 ⁰ _{-0.052}
20	2	13 ⁰ _{-0.043}
25	2	15 ⁰ _{-0.043}

Note 1) With boss in rod side:
Option
(Suffix "-XC36" to the end of part number.)

Rod end male thread

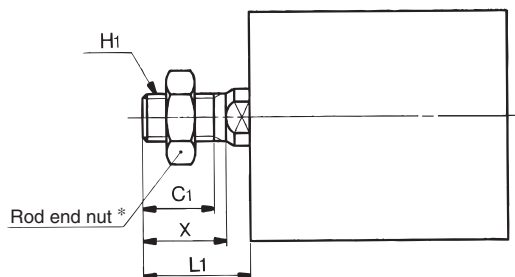

Rod End Male Thread

Bore size (mm)	C ₁	X	H ₁	L ₁
12	9	10.5	M5 x 0.8	14
16	10	12	M6 x 1.0	15.5
20	12	14	M8 x 1.25	18.5
25	15	17.5	M10 x 1.25	22.5

Auto switch shown above is D-A73 type and D-A80 type.
For the auto switch mounting position and its mounting height, refer to page 7-6-22.

Basic Style

Bore size (mm)	Stroke range (mm)	A	B	C	D	E	F	H	K	L	M	N	O	Q	S	U	V
12	5 to 30	31.5	28	6	6	32	6.5	M3 x 0.5	5	3.5	22	3.5	6.5 depth 3.5	11	35.5	19.5	25
16	5 to 30	34	30.5	8	8	38	5.5	M4 x 0.7	6	3.5	28	3.5	6.5 depth 3.5	10	41.5	22.5	29
20	5 to 50	36	31.5	7	10	47	5.5	M5 x 0.8	8	4.5	36	5.5	9 depth 7	10.5	48	24.5	36
25	5 to 50	37.5	32.5	12	12	52	5.5	M6 x 1.0	10	5	40	5.5	9 depth 7	11	53.5	27.5	40

Note 2) External dimensions with rubber bumper are same as standard type as shown above.

* For details about the rod end nut and accessory brackets, refer to page 7-6-20.

Note 3) For calculation on the longitudinal dimension of the intermediate strokes, refer to page 7-6-3.

Compact Cylinder with Auto Switch: Standard Type **Series CDQ2**

Double Acting, Single Rod

Foot style: CDQ2L

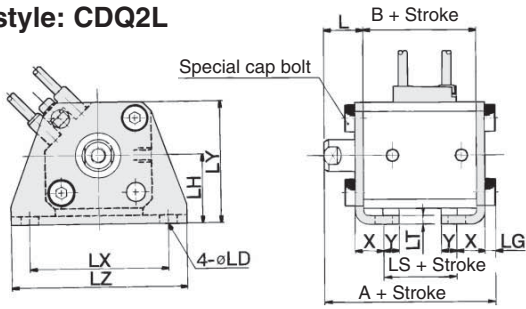

Rod end male thread

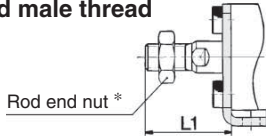

Foot Style

Bore size (mm)	Stroke range (mm)	A	B	L	L1	LD	LG	LH	LS	LT	LX	LY	LZ	X	Y
12	5 to 30	46.3	28	13.5	24	4.5	2.8	17	16	2	34	29.5	44	8	4.5
16	5 to 30	48.8	30.5	13.5	25.5	4.5	2.8	19	18.5	2	38	33.5	48	8	5
20	5 to 50	53.2	31.5	14.5	28.5	6.6	4	24	19.5	3.2	48	42	62	9.2	5.8
25	5 to 50	54.7	32.5	15	32.5	6.6	4	26	17.5	3.2	52	46	66	10.7	5.8

Foot bracket material: Carbon steel

Rod side flange style: CDQ2F

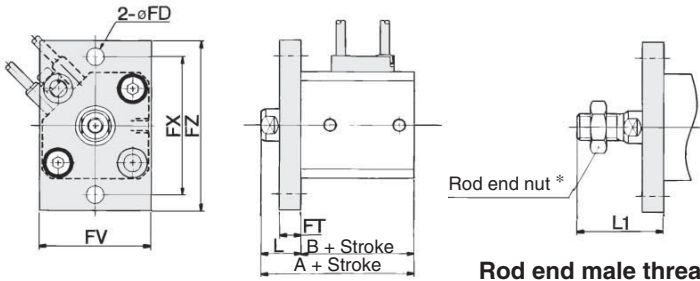

Rod end male thread

Rod Side Flange Style

Bore size (mm)	Stroke range (mm)	A	B	FD	FT	FV	FX	FZ	L	L1
12	5 to 30	41.5	28	4.5	5.5	25	45	55	13.5	24
16	5 to 30	44	30.5	4.5	5.5	30	45	55	13.5	25.5
20	5 to 50	46	31.5	6.6	8	39	48	60	14.5	28.5
25	5 to 50	47.5	32.5	6.6	8	42	52	64	15	32.5

Flange bracket material: Carbon steel

Head side flange style: CDQ2G

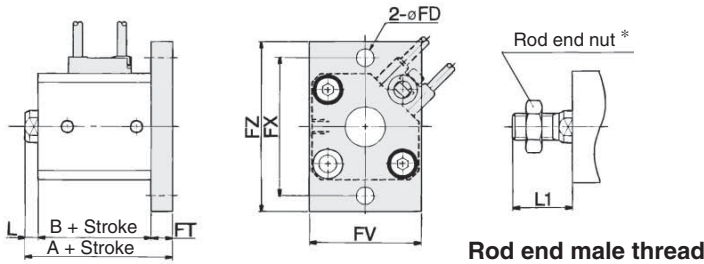

Rod end male thread

Head Side Flange Style

Bore size (mm)	Stroke range (mm)	A	L	L1
12	5 to 30	37	3.5	14
16	5 to 30	39.5	3.5	15.5
20	5 to 50	44	4.5	18.5
25	5 to 50	45.5	5	22.5

(* Dimensions except A, L and L1 are the same as rod side flange style.)

Flange bracket material: Carbon steel

Double clevis style: CDQ2G

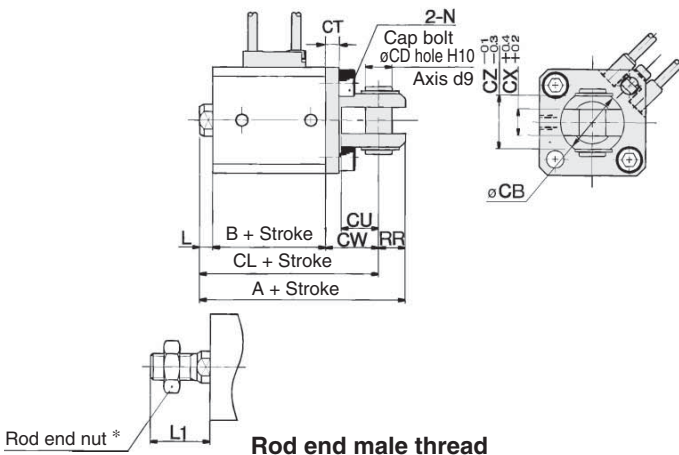

Rod end male thread

Double Clevis Style

Bore size (mm)	Stroke range (mm)	A	B	CB	CD	CL	CT	CU	CW	CX	CZ	L	L1	N	RR
12	5 to 30	51.5	28	12	5	45.5	4	7	14	5	10	3.5	14	M4 x 0.7	6
16	5 to 30	55	30.5	14	5	49	4	10	15	6.5	12	3.5	15.5	M4 x 0.7	6
20	5 to 50	63	31.5	20	8	54	5	12	18	8	16	4.5	18.5	M6 x 1.0	9
25	5 to 50	67.5	32.5	24	10	57.5	5	14	20	10	20	5	22.5	M6 x 1.0	10

Double clevis bracket material: Carbon steel

* For details about the rod end nut and accessory brackets, refer to page 7-6-20.

** Clevis pin and snap ring are shipped together.

CUJ

CU

CQS

CQM

CQ2

RQ

MU

D-

-X

20-

Data

Compact Cylinder: Standard Type Double Acting, Single Rod Series CQ2/CDQ2

Foot style: CQ2L/CDQ2L

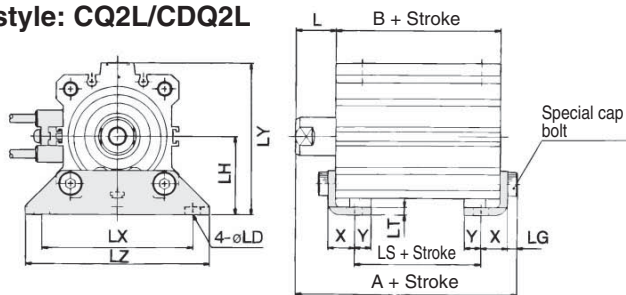

Rod end male thread

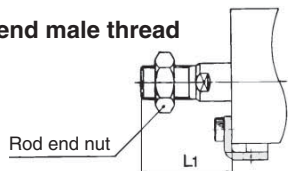

Foot Style

Bore size (mm)	Stroke range (mm)	Without auto switch			With auto switch			L	L1	LD	LG	LH	LT	LX	LY
		A	B	LS	A	B	LS								
32	5 to 50	47.2	23	7	57.2	33	17	17	38.5	6.6	4	30	3.2	57	57
	75, 100	57.2	33	17											
40	5 to 50	53.7	29.5	13.5	63.7	39.5	23.5	17	38.5	6.6	4	33	3.2	64	64
	75, 100	63.7	39.5	23.5											
50	10 to 50	56.7	30.5	7.5	66.7	40.5	17.5	18	43.5	9	5	39	3.2	79	78
	75, 100	66.7	40.5	17.5											

Foot bracket material: Carbon steel

Bore size (mm)	LZ	X	Y
32	71	11.2	5.8
40	78	11.2	7
50	95	14.7	8

Rod side flange style: CQ2F

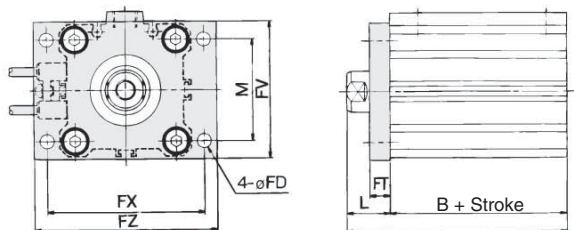

Rod end male thread

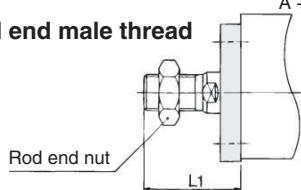

Rod Side Flange Style

Bore size (mm)	Stroke range (mm)	Without auto switch		With auto switch		FD	FT	FV	FX	FZ	L	L1	M
		A	B	A	B								
32	5 to 50	40	23	50	33	5.5	8	48	56	65	17	38.5	34
	75, 100	50	33										
40	5 to 50	46.5	29.5	56.5	39.5	5.5	8	54	62	72	17	38.5	40
	75, 100	56.5	39.5										
50	10 to 50	48.5	30.5	58.5	40.5	6.6	9	67	76	89	18	43.5	50
	75, 100	58.5	40.5										

Flange bracket material: Carbon steel

Head side flange style: CD2G/CDQ2G

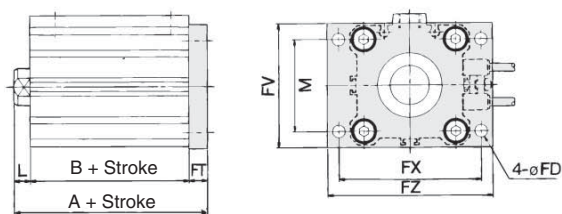

Head Side Flange Style

Bore size (mm)	Stroke range (mm)	Without auto switch	With auto switch	L	L1
		A	A		
32	5 to 50	38	48	7	28.5
	75, 100	48			
40	5 to 50	44.5	54.5	7	28.5
	75, 100	54.5			
50	10 to 50	47.5	57.5	8	33.5
	75, 100	57.5			

(* Dimensions except A, L and L1 are the same as rod side flange style.)

Flange bracket material: Carbon steel

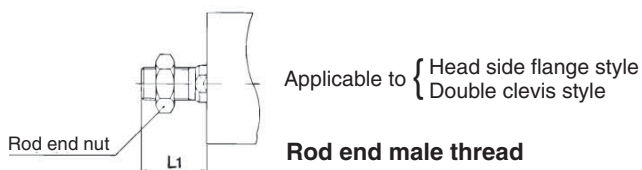

Applicable to { Head side flange style
Double clevis style

Rod end male thread

Double clevis style: CQ2D/CPQ2D

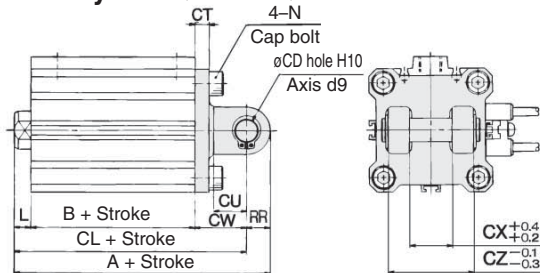

Double Clevis Style

Bore size (mm)	Stroke range (mm)	Without auto switch			With auto switch			CD	CT	CU	CW	CX	CZ	L	L1
		A	B	CL	A	B	CL								
32	5 to 50	60	23	50	70	33	60	10	5	14	20	18	36	7	28.5
	75, 100	70	33	60											
40	5 to 50	68.5	29.5	58.5	78.5	39.5	68.5	10	6	14	22	18	36	7	28.5
	75, 100	78.5	39.5	68.5											
50	10 to 50	80.5	30.5	66.5	90.5	40.5	76.5	14	7	20	28	22	44	8	33.5
	75, 100	90.5	40.5	76.5											

Double clevis bracket material: Cast iron

Bore size (mm)	N	RR
32	M6 x 1.0	10
40	M6 x 1.0	10
50	M8 x 1.25	14

* For details about the rod end nut and accessory brackets, refer to page 7-6-20.
** Clevis pin and snap ring are shipped together.

Series CQ2/CDQ2

Dimensions: $\varnothing 63$ to $\varnothing 100$

Basic style (Through-hole)

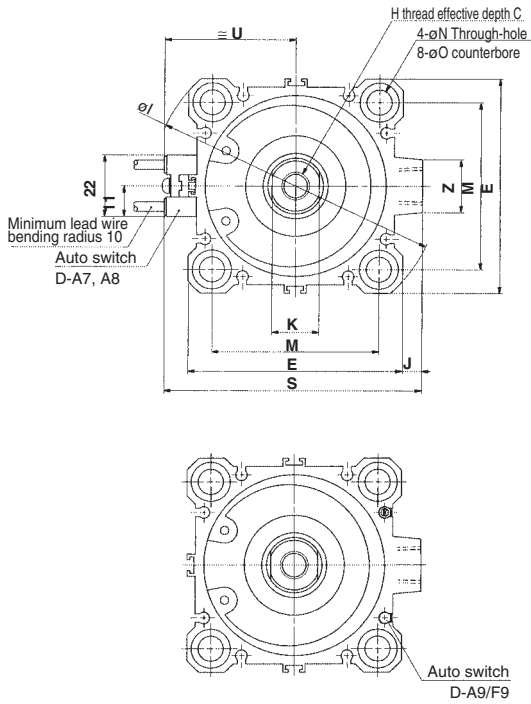

Basic style (Through-hole)

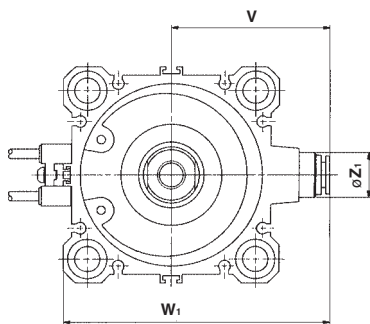

Both ends tapped style: CQ2A/CDQ2A

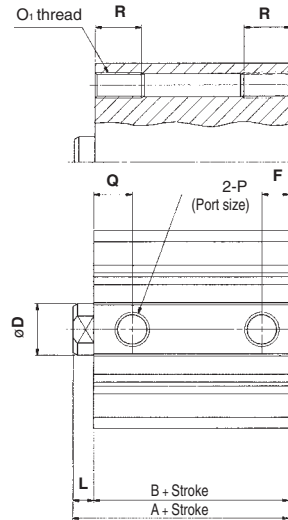

With boss in head side

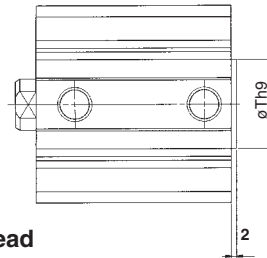

Rod end male thread

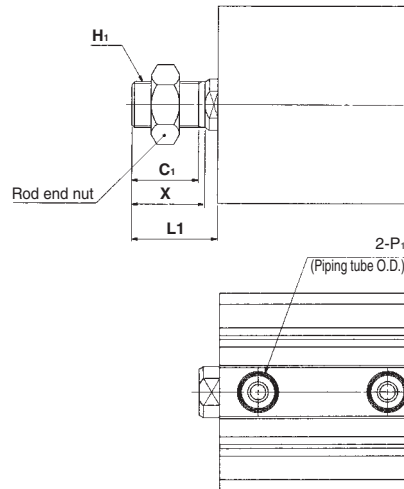

Both Ends Tapped Style

Bore size (mm)	O ₁	R
63	M10 x 1.5	18
80	M12 x 1.75	22
100	M12 x 1.75	22

With Boss in Head Side

Bore size (mm)	Th9
63	35 ⁰ _{-0.062}
80	43 ⁰ _{-0.062}
100	59 ⁰ _{-0.074}

Note 1) With boss in rod side:
Option
(Suffix "-XC36" to the end of part number.)

Rod End Male Thread

Bore size (mm)	C ₁	X	H ₁	L ₁
63	26	28.5	M18 x 1.5	33.5
80	32.5	35.5	M22 x 1.5	43.5
100	32.5	35.5	M26 x 1.5	43.5

Built-in One-touch Fittings

Bore size (mm)	Z ₁	P ₁	V	W ₁
63	16	8	56.5	95

Basic Style Auto switch shown above is D-A73 type and D-A80 type. For the auto switch mounting position and its mounting height, refer to page 7-6-22.

Bore size (mm)	Stroke range (mm)	Without auto switch		With auto switch		C	D	E	F	H	I	J	K	L	M	N	O	P	Q	S
		A	B	A	B															
63	10 to 50	44	36	54	46	15	20	77	10.5	M10 x 1.5	103	7	17	8	60	9	14 depth 10.5	Rc 1/4	15	93
	75, 100	54	46																	
80	10 to 50	53.5	43.5	63.5	53.5	21	25	98	12.5	M16 x 2.0	132	6	22	10	77	11	17.5 depth 13.5	Rc 3/8	16	112.5
	75, 100	63.5	53.5																	
100	10 to 50	65	53	75	63	27	30	117	13	M20 x 2.5	156	6.5	27	12	94	11	17.5 depth 13.5	Rc 3/8	23	132.5
	75, 100	75	63																	

Bore size (mm)	U	Z
63	47.5	19
80	57.5	26
100	67.5	26

Note 2) External dimensions with rubber bumper are same as standard type as shown above.

* For details about the rod end nut and accessory brackets, refer to page 7-6-20.

Note 3) For calculation on the longitudinal dimension of the intermediate strokes, refer to page 7-6-3.

Compact Cylinder: Standard Type Double Acting, Single Rod Series **CQ2/CDQ2**

Foot style: CQ2L/CDQ2L

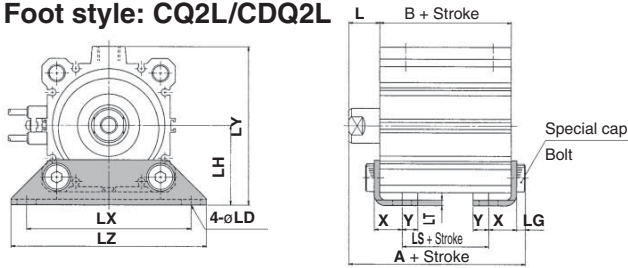

Rod end male thread

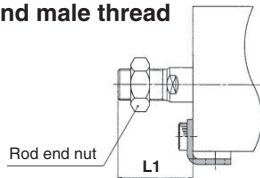

Head side flange style: CQ2G/CDQ2G

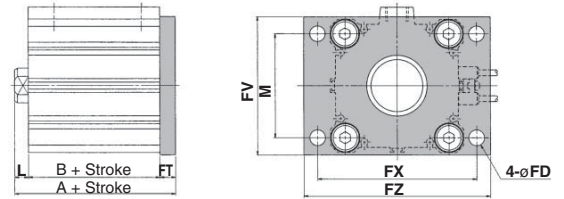

Rod end male thread

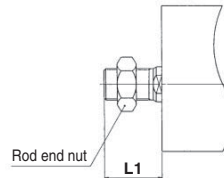

Rod side flange style: CQ2F/CDQ2F

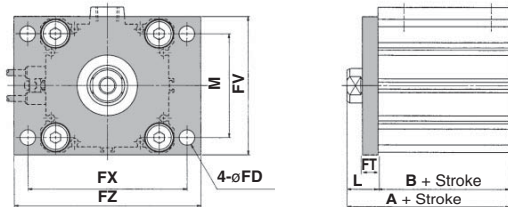

Rod end male thread

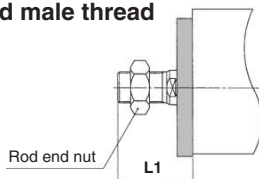

Double clevis style: CQ2D/CDQ2D

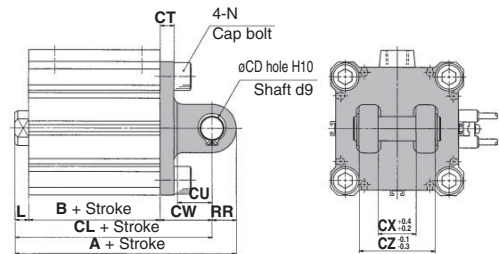

Rod end male thread

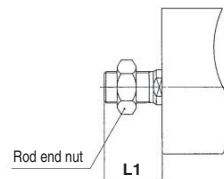

Foot Style

Bore size (mm)	Stroke range (mm)	Without auto switch			With auto switch			L	L1	LD	LG	LH	LT
		A	B	LS	A	B	LS						
63	10 to 50	62.2	36	10	72.2	46	20	18	43.5	11	5	46	3.2
	75, 100	72.2	46	20									
80	10 to 50	75	43.5	13.5	85	53.5	23.5	20	53.5	13	7	59	4.5
	75, 100	85	53.5	23.5									
100	10 to 50	88	53	19	98	63	29	22	53.5	13	7	71	6
	75, 100	98	63	29									

Foot bracket material: Carbon steel

Bore size (mm)	Stroke range (mm)	LX	LY	LZ	X	Y
63	10 to 50	95	91.5	113	16.2	9
	75, 100					
80	10 to 50	118	114	140	19.5	11
	75, 100					
100	10 to 50	137	136	162	23	12.5
	75, 100					

Rod Side Flange Style

Bore size (mm)	Stroke range (mm)	Without auto switch		With auto switch		FD	FT	FV	FX	FZ	L	L1	M
		A	B	A	B								
63	10 to 50	54	36	64	46	9	9	80	92	108	18	43.5	60
	75, 100	64	46										
80	10 to 50	63.5	43.5	73.5	53.5	11	11	99	116	134	20	53.5	77
	75, 100	73.5	53.5										
100	10 to 50	75	53	85	63	11	11	117	136	154	22	53.5	94
	75, 100	85	63										

Flange bracket material: Carbon steel

Head Side Flange Style

Bore size (mm)	Stroke range (mm)	Without auto switch		With auto switch		L	L1
		A	B	A	B		
63	10 to 50	53		63		8	33.5
	75, 100	63					
80	10 to 50	64.5		74.5		10	43.5
	75, 100	74.5					
100	10 to 50	76		86		12	43.5
	75, 100	86					

Flange bracket material: Carbon steel

Double Clevis Style

Bore size (mm)	Stroke range (mm)	Without auto switch		With auto switch		CD	CL	CT	CU	CW	CX	CZ	L
		A	B	A	B								
63	10 to 50	88	36	98	46	14	84	8	20	30	22	44	8
	75, 100	98	46										
80	10 to 50	109.5	43.5	119.5	53.5	18	101.5	10	27	38	28	56	10
	75, 100	119.5	53.5										
100	10 to 50	132	53	142	63	22	120	13	31	45	32	64	12
	75, 100	142	63										

Double clevis bracket material: Cast iron

Bore size (mm)	Stroke range (mm)	L1	N	RR
63	10 to 50	33.5	M10 x 1.5	14
	75, 100			
80	10 to 50	43.5	M12 x 1.75	18
	75, 100			
100	10 to 50	43.5	M12 x 1.75	22
	75, 100			

* For details about the rod end nut and accessory brackets, refer to page 7-6-20.
* Clevis pin and set ring are shipped together.

Series CQ2

Accessory Bracket

Single Knuckle Joint

For I-G012, I-Z015A
I-G02, I-G03

For I-G04, I-G05
I-G08, I-G10

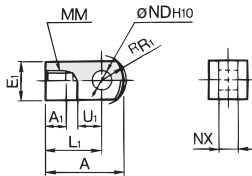

Material: Carbon steel

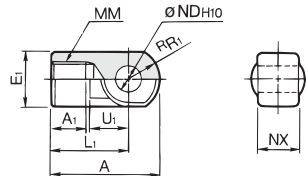

Material: Cast iron

Double Knuckle Joint

For Y-G012, Y-Z015A
Y-G02, Y-G03

For Y-G04, Y-G05
Y-G08, Y-G10

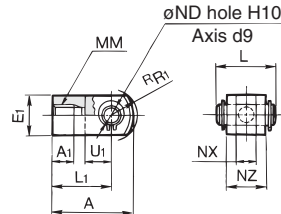

Material: Carbon steel

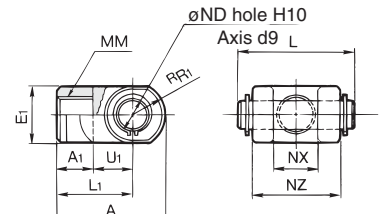

Material: Cast iron

Part no.	Applicable bore size (mm)	A	A ₁	E ₁	L ₁	MM	R _{R1}	U ₁	ND _{H10}	NX
I-G012	12	21.5	6	□10	16	M5 x 0.8	6.3	7	5 ^{+0.048} ₀	5 ^{-0.2} _{-0.4}
I-Z015A	16	32	8	□12	25	M6 x 1	8.1	14	5 ^{+0.048} ₀	6.4 ^{-0.1} _{-0.3}
I-G02	20	34	8.5	□16	25	M8 x 1.25	10.3	11.5	8 ^{+0.058} ₀	8 ^{-0.2} _{-0.4}
I-G03	25	41	10.5	□20	30	M10 x 1.25	12.8	14	10 ^{+0.058} ₀	10 ^{-0.2} _{-0.4}
I-G04	32, 40	42	14	∅22	30	M14 x 1.5	12	14	10 ^{+0.058} ₀	18 ^{-0.3} _{-0.5}
I-G05	50, 63	56	18	∅28	40	M18 x 1.5	16	20	14 ^{+0.070} ₀	22 ^{-0.3} _{-0.5}
I-G08	80	71	21	∅38	50	M22 x 1.5	21	27	18 ^{+0.070} ₀	28 ^{-0.3} _{-0.5}
I-G10	100	79	21	∅44	55	M26 x 1.5	24	31	22 ^{+0.084} ₀	32 ^{-0.3} _{-0.5}

Part no.	Applicable bore size (mm)	A	A ₁	E ₁	L ₁	MM	R _{R1}	U ₁	ND _{H10}	NX	NZ	L	Applicable pin part no.
Y-G012	12	21.5	6	□10	16	M5 x 0.8	6.3	7	5 ^{+0.048} ₀	5 ^{+0.4} _{-0.2}	10	14.6	IY-G012
Y-Z015A	16	28	11	□12	21	M6 x 1	8.1	10	5 ^{+0.048} ₀	6.5 ^{+0.2} _{-0.2}	12	16.6	IY-J015
Y-G02	20	34	8.5	□16	25	M8 x 1.25	10.3	11.5	8 ^{+0.058} ₀	8 ^{+0.4} _{-0.2}	16	21	IY-G02
Y-G03	25	41	10.5	□20	30	M10 x 1.25	12.8	14	10 ^{+0.058} ₀	10 ^{+0.4} _{-0.2}	20	25.6	IY-G03
Y-G04	32, 40	42	16	∅22	30	M14 x 1.5	12	14	10 ^{+0.058} ₀	18 ^{+0.5} _{-0.3}	36	41.6	IY-G04
Y-G05	50, 63	56	20	∅28	40	M18 x 1.5	16	20	14 ^{+0.070} ₀	22 ^{+0.5} _{-0.3}	44	50.6	IY-G05
Y-G08	80	71	23	∅38	50	M22 x 1.5	21	27	18 ^{+0.070} ₀	28 ^{+0.5} _{-0.3}	56	64	IY-G08
Y-G10	100	79	24	∅44	55	M26 x 1.5	24	31	22 ^{+0.084} ₀	32 ^{+0.5} _{-0.3}	64	72	IY-G10

* Knuckle pin and snap ring are included.

Knuckle Pin (Common with double clevis pin)

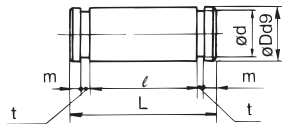

Material: Carbon steel

Part no.	Applicable bore size (mm)	Dd9	L	d	ℓ	m	t	Applicable snap ring
IY-G012	12	5 ^{-0.030} _{-0.060}	14.6	4.8	10.2	1.5	0.7	Type C 5 for axis
IY-J015	16	5 ^{-0.030} _{-0.060}	16.6	4.8	12.2	1.5	0.7	Type C 5 for axis
IY-G02	20	8 ^{-0.040} _{-0.076}	21	7.6	16.2	1.5	0.9	Type C 8 for axis
IY-G03	25	10 ^{-0.040} _{-0.076}	25.6	9.6	20.2	1.55	1.15	Type C 10 for axis
IY-G04	32, 40	10 ^{-0.040} _{-0.076}	41.6	9.6	36.2	1.55	1.15	Type C 10 for axis
IY-G05	50, 63	14 ^{-0.050} _{-0.093}	50.6	13.4	44.2	2.05	1.15	Type C 14 for axis
IY-G08	80	18 ^{-0.050} _{-0.093}	64	17	56.2	2.55	1.35	Type C 18 for axis
IY-G10	100	22 ^{-0.065} _{-0.117}	72	21	64.2	2.55	1.35	Type C 22 for axis

Rod End Nut

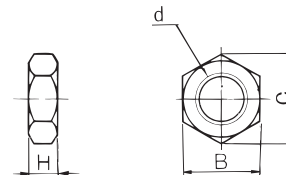

Material: Carbon steel

Part no.	Applicable bore size (mm)	d	H	B	C
NTJ-015A	12	M5 x 0.8	4	8	9.2
NT-015A	16	M6 x 1	5	10	11.5
NT-02	20	M8 x 1.25	5	13	15.0
NT-03	25	M10 x 1.25	6	17	19.6
NT-04	32, 40	M14 x 1.5	8	22	25.4
NT-05	50, 63	M18 x 1.5	11	27	31.2
NT-08	80	M22 x 1.5	13	32	37.0
NT-10	100	M26 x 1.5	16	41	47.3

Simple Joint: $\phi 32$ to $\phi 100$

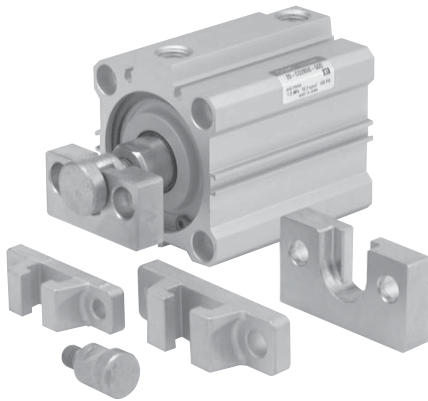

Joint and Mounting Bracket (Type A, Type B) Part No.

YA — **03**

- Applicable air cylinder bore
 - Mounting bracket
- | | |
|-----------|------------------------|
| 03 | For $\phi 32, \phi 40$ |
| 05 | For $\phi 50, \phi 63$ |
| 08 | $\phi 80$ |
| 10 | $\phi 100$ |
- | | |
|-----------|-------------------------|
| YA | Type A mounting bracket |
| YB | Type B mounting bracket |
| YU | Joint |

Allowable Eccentricity

Bore size (mm)	32	40	50	63	80	100
Eccentricity tolerance	± 1				± 1.5	± 2
Backlash	0.5					

<Ordering>

- Joints are not included with the A or B type mounting brackets. Order them separately.

(Example)

- Bore size $\phi 40$ Part no.
- Type A mounting bracket part no. YA-03
- Joint YU-03

Joint Part No.

Bore size (mm)	Joint part no.	Applicable mounting bracket		Weight (g)
		Type A mounting bracket	Type B mounting bracket	
32, 40	YU-03	YA-03	YB-03	25
50, 63	YU-05	YA-05	YB-05	40
80	YU-08	YA-08	YB-08	90
100	YU-10	YA-10	YB-10	160

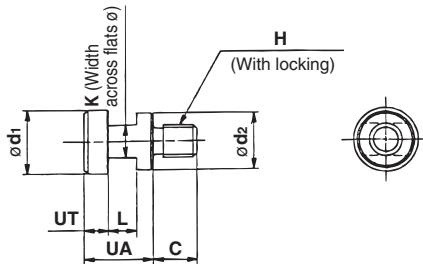

Material: Chromium molybdenum steel (Nickel plated)

Part no.	Applicable bore size (mm)	UA	C	d ₁	d ₂	H	K	L	UT	Weight (g)
YU-03	32, 40	17	11	15.8	14	M8 x 1.25	8	7	6	25
YU-05	50, 63	17	13	19.8	18	M10 x 1.5	10	7	6	40
YU-08	80	22	20	24.8	23	M16 x 2	13	9	8	90
YU-10	100	26	26	29.8	28	M20 x 2.5	14	11	10	160

Type A Mounting Bracket

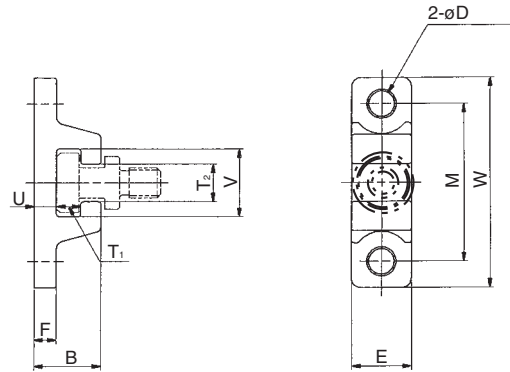

Material: Chromium molybdenum steel (Nickel plated)

Part no.	Bore size (mm)	B	D	E	F	M	T ₁	T ₂
YA-03	32, 40	18	6.8	16	6	42	6.5	10
YA-05	50, 63	20	9	20	8	50	6.5	12
YA-08	80	26	11	25	10	62	8.5	16
YA-10	100	31	14	30	12	76	10.5	18

Part no.	Bore size (mm)	U	V	W	Weight (g)
YA-03	32, 40	6	18	56	55
YA-05	50, 63	8	22	67	100
YA-08	80	10	28	83	195
YA-10	100	12	36	100	340

Type B Mounting Bracket

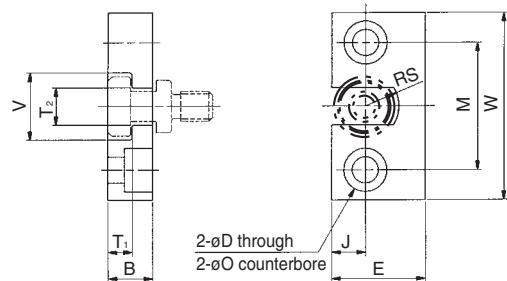

Material: Precision die-casting material equivalent to stainless steel 304

Part no.	Bore size (mm)	B	D	E	J	M	ϕO
YB-03	32, 40	12	7	25	9	34	11.5 depth 7.5
YB-05	50, 63	12	9	32	11	42	14.5 depth 8.5
YB-08	80	16	11	38	13	52	18 depth 12
YB-10	100	19	14	50	17	62	21 depth 14

Part no.	Bore size (mm)	T ₁	T ₂	V	W	RS	Weight (g)
YB-03	32, 40	6.5	10	18	50	9	80
YB-05	50, 63	6.5	12	22	60	11	120
YB-08	80	8.5	16	28	75	14	230
YB-10	100	10.5	18	36	90	18	455

CUJ

CU

CQS

CQM

CQ2

RQ

MU

D-

-X

20-

Data

Series CDQ2

Proper Auto Switch Mounting Position (Detection at stroke end) and Its Mounting Height

D-A7□
D-A80

ø12 to ø25

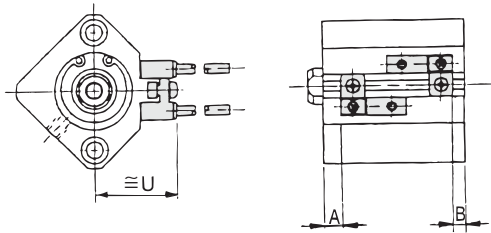

ø32 to ø100

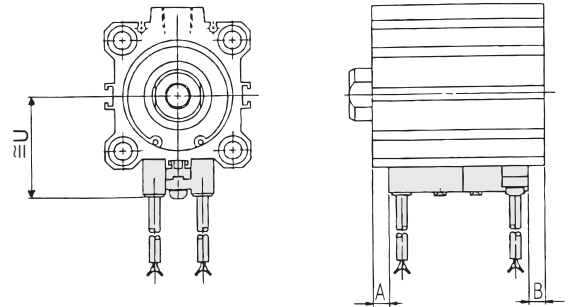

D-A7□H
D-A80H
D-F7□
D-J79
D-F7□W
D-J79W
D-F79F
D-F7NTL
D-F7BAL

ø12 to ø25

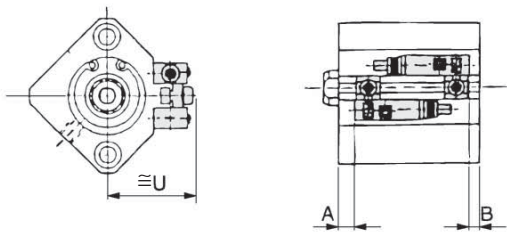

ø32 to ø100

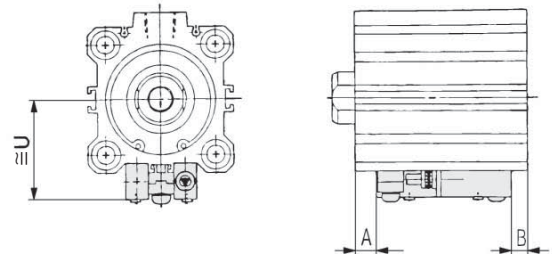

D-A73C
D-A80C
D-J79C

ø12 to ø25

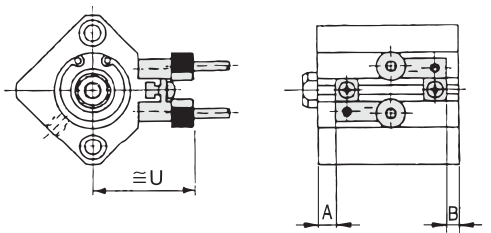

ø32 to ø100

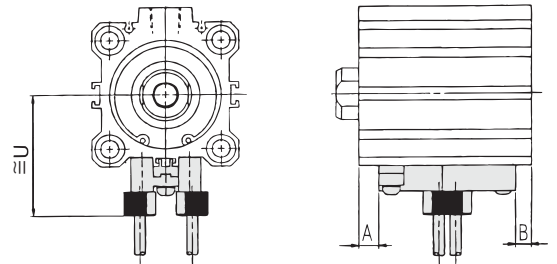

D-A79W
D-F7□WV
D-F7□V
D-F7BAVL

ø12 to ø25

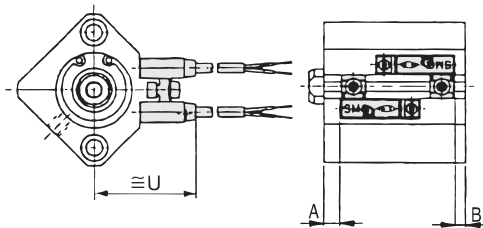

ø32 to ø100

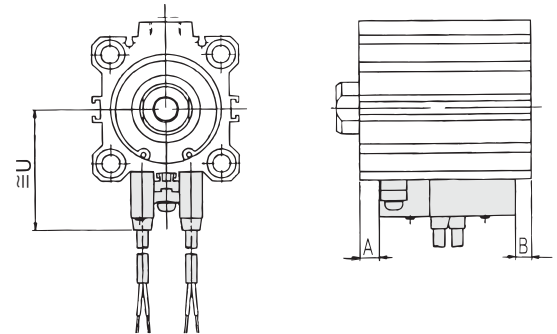

ø32 to ø100

D-A9□
D-M9□
D-F9□W

D-A9□V
D-M9□V
D-F9□WV

D-F9BAL

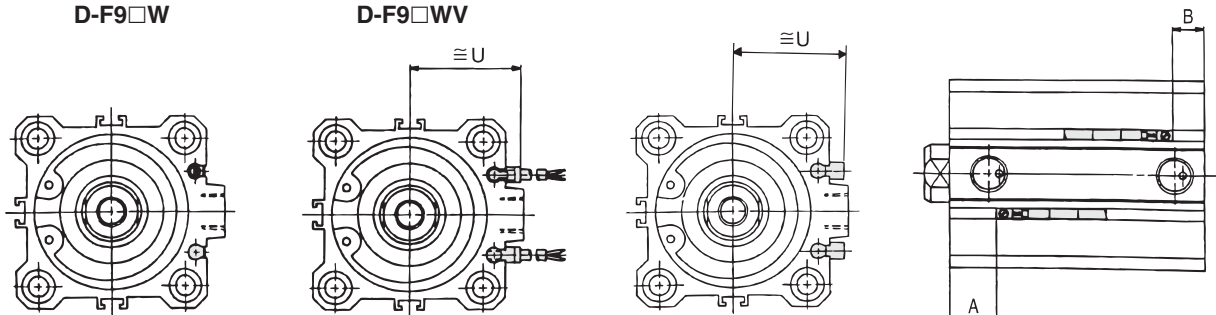

Compact Cylinder with Auto Switch: Standard Type Double Acting, Single Rod **Series CDQ2**

Operating Range

Auto switch model	Bore size (mm)														
	12	16	20	25	32	40	50	63	80	100	125	140	160	180	200
D-A7□(H)(C) D-A80□(H)(C)	10	12	12	12	12	11	10	12	12	13	13	13	13	—	—
D-A9□(V)	—	—	—	—	9.5	9.5	9.5	11.5	9	11.5	—	—	—	—	—
D-Z7□ D-Z80	—	—	—	—	—	—	—	—	—	—	14	14	14	15	15.5
D-F7□(V) D-J79(C) D-F7□W(V) D-F7BA(V)L D-F7NTL D-F79F	5.5	6	5.5	5	6	6	6	6.5	6.5	7	9	9	8.5	—	—
D-F9□(V) D-F9□W(V) D-F9BA(V)L D-Y59□	—	—	—	—	5.5	5.5	5.5	6.5	5.5	6.5	—	—	—	—	—
D-Y69□ D-Y7P(V) D-Y7□W(V)	—	—	—	—	—	—	—	—	—	—	11.5	11.5	11.5	12	12
D-Y7BAL D-P5DW	—	—	—	—	—	—	—	—	—	—	5.5	5.5	5.5	6	6

* Since this is a guideline including hysteresis, not meant to be guaranteed. (Assuming approximately ±30% dispersion)
There may be the case to change substantially depending on an ambient environment.

Other than the applicable auto switches listed in "How to Order", the following auto switches can be mounted. For detailed specifications, refer to page 7-9-1.

Type	Model	Electrical entry (Fetching direction)	Features	Applicable bore size (mm)
Reed switch	D-A80	Grommet (Perpendicular)	Without indicator light	12 to 160
	D-A80H	Grommet (In-line)		
	D-A80C	Connector (Perpendicular)		125 to 200
	D-Z80	Grommet (In-line)		
	D-A90	Grommet (In-line)		32 to 100
Solid state switch	D-A90V	Grommet (Perpendicular)	With timer	12 to 160
	D-F7NNTL	Grommet (In-line)		

* With pre-wire connector is available for D-F7NNTL type, too. For details, refer to page 7-9-36.

* Normally closed (NC = b contact), solid state switches (D-F9G/F9H/Y7G/Y7H type) are available, too. For details, refer to page 7-9-23 and 24.

CUJ

CU

CQS

CQM

CQ2

RQ

MU

D-

-X

20-

Data

Series CDQ2

Proper Auto Switch Mounting Position (Detection at stroke end) and Its Mounting Height

ø40 to ø100

D-P5DWL

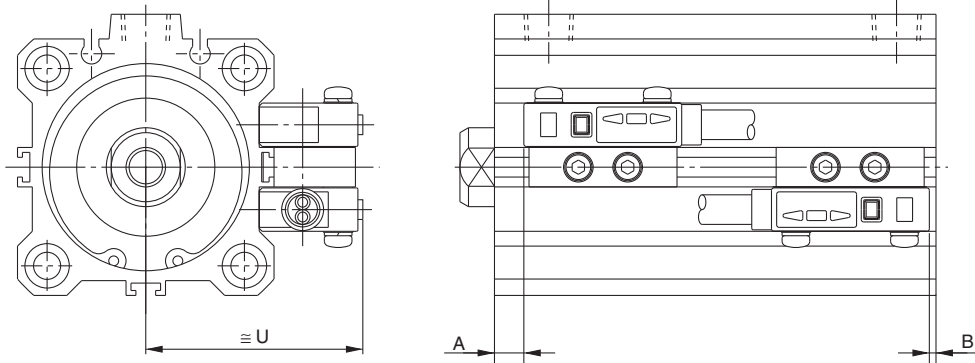

Proper Auto Switch Mounting Position

Bore size (mm)	D-A7□/A80		D-A7□H/A80H D-A73C/A80C D-F7□/J79/J79W D-F7□V/J79C D-F7□W/F7□WV D-F7BAL/F7BAVL D-F79F		D-A79W		D-A9□ D-A9□V		D-M9□ D-M9□V D-F9□W D-F9□WV		D-F9BAL		D-P5DWL	
	A	B	A	B	A	B	A	B	A	B	A	B	A	B
12	4.5	5.5	5	6	2	3	—	—	—	—	—	—	—	—
16	7.5	5	8	5.5	5	2.5	—	—	—	—	—	—	—	—
20	7.5	6.5	8	7	5	4	—	—	—	—	—	—	—	—
25	7.5	7	8	7.5	5	4.5	—	—	—	—	—	—	—	—
32	9.0	6	9.5	6.5	6.5	3.5	8	5	12	9	11	8	—	—
40	13	8.5	13.5	9	10.5	6	12	7.5	16	11.5	15	10.5	9	4.5
50	11	11.5	11.5	12	8.5	9	10	10.5	14	14.5	13	13.5	7	7.5
63	13.5	14.5	14	15	11	12	12.5	13.5	16.5	17.5	15.5	16.5	9.5	10.5
80	17.5	18	18	18.5	15	15.5	16.5	17	20.5	21	19.5	20	13.5	14
100	21	24	21.5	24.5	18.5	21.5	20	23	24	27	23	26	17	20

Auto Switch Mounting Height

Bore size (mm)	D-A7□ D-A80	D-A7□H D-A80H D-F7□ D-J79 D-F7□W	D-J79W D-F7BAL D-F79F D-F7NTL	D-A73C D-A80C	D-F7□V D-F7□WV D-F7BAVL	D-J79C	D-A79W	D-A9□V	D-M9□V D-F9□WV	D-F9BAL	D-P5DWL
	U	U	U	U	U	U	U	U	U	U	U
12	19.5	20.5	26.5	23	26	22	—	—	—	—	—
16	22.5	23.5	29.5	26	29	25	—	—	—	—	—
20	24.5	25.5	31.5	28	31	27	—	—	—	—	—
25	27.5	28.5	34.5	31	34	30	—	—	—	—	—
32	31.5	32.5	38.5	35	38	34	27	29	26.5	—	—
40	35	36	42	38.5	41.5	37.5	30.5	32.5	30	44	—
50	41	42	48	44.5	47.5	43.5	36.5	38.5	36	50	—
63	47.5	48.5	54.5	51	54	50	40	42	39.5	56.5	—
80	57.5	58.5	64.5	61	64	60	50	52	49.5	66.5	—
100	67.5	68.5	74.5	71	74	70	60	62	59.5	76.5	—



Compact Cylinder: Standard Type Double Acting, Double Rod Series CQ2W

ø12, ø16, ø20, ø25, ø32, ø40, ø50, ø63, ø80, ø100

How to Order

Without auto switch
CQ2W B [] 20 [] 30 D []

With auto switch
CDQ2W B [] 20 [] 30 D [] J79W S

Built-in magnet

Mounting style

B	Through-hole (Standard)	L	Foot style
A	Both ends tapped style	F	Flange style

* Mounting brackets are shipped together, (but not assembled).

Type

Nil	Pneumatic
H	Air-hydro ^{Note)}

Note) Bore sizes available for air-hydro type are ø20 to ø63

Bore size

12	12 mm	40	40 mm
16	16 mm	50	50 mm
20	20 mm	63	63 mm
25	25 mm	80	80 mm
32	32 mm	100	100 mm

Piping

Nil	Screw-in piping
F	Built-in One-touch fittings ^{Note)}

Note) Available bore sizes w/ One-touch fittings are ø32 to ø63. Besides, it is not possible to use for air-hydro type.

Auto switch

Nil	Without auto switch (Built-in magnet)
S	1 pc.
n	"n" pcs.

* For the applicable auto switch model, refer to the table below.
* Auto switches are shipped together, (but not assembled). (Except D-P5DWL)

Body option

Nil	Standard (Rod end female thread)
C	With rubber bumper ^{Note)}
M	Rod end male thread

* Combination of body options ("CM") is available.
Note) Air-hydro type with rubber bumper is not available.

Action

D	Double acting
----------	---------------

Cylinder stroke (mm)
Refer to "Standard Stroke" on page 7-6-26.

- CUJ
- CU
- CQS
- CQM
- CQ2**
- RQ
- MU
- D-
- X
- 20-
- Data

Applicable Auto Switch/Refer to page 7-9-1 for further information on auto switches.

Type	Special function	Electrical entry	Indicator/light	Wiring (Output)	Load voltage		Rail mounting		Direct mounting		Lead wire length (m) *				Pre-wire connector	Applicable load				
					DC	AC	ø12 to ø100		ø32 to ø100		0.5 (Nil)	3 (L)	5 (Z)	None (N)		IC circuit	Relay, PLC			
							Perpendicular	In-line	Perpendicular	In-line										
Reed switch	—	Grommet	Yes	3-wire (NPN equivalent)	—	5V	—	—	A76H	A96V	A96	●	●	—	—	—	IC circuit	—		
				2-wire	24 V	12 V	100 V	A72	A72H	—	—	●	●	—	—	—	—	—	Relay, PLC	
								—	—	A93V	A93	●	●	—	—	—	—			
								A73C	—	—	—	●	●	●	●	—	—			
Diagnostic indication (2-color indication)	Grommet	—	—	—	—	—	—	A79W	—	—	—	—	—	—	—	—				
Solid state switch	—	Grommet	Yes	3-wire (NPN)	5V, 12V	—	—	F7NV	F79	M9NV	M9N	●	●	○	—	○	IC circuit	—		
				3-wire (PNP)				F7PV	F7P	M9PV	M9P	●	●	○	—	○				
		Connector		2-wire	12 V	—	—	F7BV	J79	M9BV	M9B	●	●	○	—	○	—	—	—	
								J79C	—	—	—	●	●	●	●	—	—			
		Grommet		2-wire	24 V	12 V	—	F7NVV	F79W	F9NVV	F9NW	●	●	○	—	○	—	○	IC circuit	Relay, PLC
								—	F7PW	F9PWV	F9PW	●	●	○	—	○				
								F7BWW	J79W	F9BWW	F9BW	●	●	○	—	○				
								—	F7BA	—	F9BA	—	●	○	—	○				
								F7BAV	—	—	—	—	●	○	—	—				
								—	F79F	—	—	●	●	○	—	○				
Water resistant (2-color indication)	Grommet	2-wire	24 V	12 V	—	—	—	—	—	—	—	●	●	○	—	○	IC circuit			
With diagnostic output (2-color indication)																				
Magnetic field resistant (2-color indication)																				
—																				

* Lead wire length symbols: 0.5 m..... Nil (Example) A73C
 3 m..... L (Example) A73CL
 5 m..... Z (Example) A73CZ
 None..... N (Example) A73CN

* Solid state switches marked with "○" are produced upon receipt of order.

- D-P5DWL type is available from ø40 up to ø100 only.
- There are other applicable auto switches other than the listed above. For details, refer to page 7-6-23.
- For details about auto switches with pre-wire connector, refer to page 7-9-36.

Series CQ2W



JIS Symbol

Double acting,
double rod



⚠ Precautions

**Be sure to read before handling.
For Safety Instructions and
Actuator Precautions, refer to
pages 7-13-3 to 7-13-6.**

Snap Ring Installation/Removal

⚠ Caution

1. For installation and removal, use an appropriate pair of pliers (tool for installing a type C snap ring).

- Even if a proper plier (tool for installing type C snap ring) is used, it is likely to inflict damage to a human body or peripheral equipment, as a snap ring may be flown out of the tip of a plier (tool for installing a type C snap ring). Be much careful with the popping of a snap ring. Besides, be certain that a snap ring is placed firmly into the groove of rod cover before supplying air at the time of installment.

Mounting

1. When removing a load, be sure to secure the wrench flats of the piston rod on the load side.
2. If this is done without securing the piston rod on the load side, be aware that the coupled (screwed-in) portion of the piston rod could become loosened.

Type

Bore size (mm)		12	16	20	25	32	40	50	63	80	100	
Pneumatic	Mounting	Through-hole (Standard)	●	●	●	●	●	●	●	●	●	
		Both ends tapped style	●	●	●	●	●	●	●	●	●	
	Built-in magnet		●	●	●	●	●	●	●	●	●	
	Piping	Screw-in type	M5 x 0.8	M5 x 0.8	M5 x 0.8	M5 x 0.8	M5 x 0.8 ⁽¹⁾ Rc 1/8	Rc 1/8	Rc 1/4	Rc 1/4	Rc 3/8	Rc 3/8
		Built-in One-touch fittings		—	—	—	—	ø6/4 ⁽²⁾	ø6/4	ø8/6	ø8/6	—
	Rod end male thread		●	●	●	●	●	●	●	●	●	●
With rubber bumper		●	●	●	●	●	●	●	●	●	●	
Air-hydro	Mounting	Through-hole (Standard)	—	—	●	●	●	●	●	●	●	
		Both ends tapped style	—	—	●	●	●	●	●	●	●	
	Built-in magnet		—	—	●	●	●	●	●	●	●	
	Piping	Screw-in type	—	—	M5 x 0.8	M5 x 0.8	M5 x 0.8 ⁽¹⁾ Rc 1/8	Rc 1/8	Rc 1/4	Rc 1/4	Rc 3/8	Rc 3/8
Rod end male thread		—	—	●	●	●	●	●	●	●	●	



Note 1) In the case of without auto switch, M5 x 0.8 is used for 5 stroke only.

Note 2) In the case of built-in fitting, the 5 mm stroke with ø32 bore is the same external dimensions as 10 mm stroke.

Specifications

Type	Pneumatic (Non-lube)	Air-hydro
Fluid	Air	Turbine oil ⁽³⁾
Proof pressure	1.5 MPa	
Maximum operating pressure	1.0 MPa	
Ambient and fluid temperature	Without auto switch: -10 to 70°C (No freezing) With auto switch: -10 to 60°C (No freezing)	Air-hydro 5 to 60°C
Rubber bumper	None	—
Rod end thread	Female thread	
Rod end thread tolerance	JIS Class 2	
Stroke length tolerance	+1.0 0	
Mounting	Through-hole	
Piston speed	50 to 500 mm/s	5 to 50 mm/s



Note 3) For caution on handling, refer to page 7-13-6.

Standard Stroke

Pneumatic (Non-lube)

Bore size (mm)	Standard stroke
12, 16	5, 10, 15, 20, 25, 30
20, 25	5, 10, 15, 20, 25, 30, 35, 40, 45, 50
32, 40	5, 10, 15, 20, 25, 30, 35, 40, 50, 75, 100
50, 63 80, 100	10, 15, 20, 25, 30, 35, 40, 45, 50, 75, 100

Air-hydro

Bore size (mm)	Standard stroke
20, 25	5, 10, 15, 20, 25, 30, 35, 40, 45, 50
32, 40	5, 10, 15, 20, 25, 30, 35, 40, 45, 50, 75, 100
50, 63 80, 100	10, 15, 20, 25, 30, 35, 40, 45, 50, 75, 100

Manufacture of Intermediate Stroke

Description	Spacer is installed in the standard stroke body.	Exclusive body (-XB10)
Part no.	"How to Order" for the standard model no. on page 7-6-25.	Suffix "-XB10" to the end of standard model no. on page 7-6-25.
Description	Dealing with the stroke by the 5 mm interval is available by installing spacer with standard stroke cylinder.	Dealing with the stroke by the 1 mm interval by using an exclusive body with the specified stroke.
Stroke range	Bore size	Bore size
	Stroke range	Stroke range
	—	—
Example	Part no.: CQ2WB50-65D CQ2WB50-75D with 10 mm spacer inside. B dimension is 125.5 mm.	Part no.: CQ2WB50-65D-XB10 Makes 65 stroke tube. B dimension is 115.5 mm.

• Air-hydro type is excluded.

• In the case of special body type for ø32 to ø100 (-XB10), standard value for longitudinal dimensions will be changed.

Subtract from 75 and 100 stroke dimensions and figure it out.

Compact Cylinder: Standard Type Double Acting, Double Rod Series CQ2W



Made to Order Specifications (For details, refer to page 7-10-1.)

Symbol	Specifications
-XA□	Change of rod end shape
-XB6	Heat resistant cylinder (150°C) w/o auto switch only
-XB7	Cold resistant cylinder w/o auto switch only
-XB9	Low speed cylinder (10 to 50 mm/s)
-XB10	Intermediate stroke (Using exclusive body)
-XB13	Low speed cylinder (5 to 50 mm/s)
-XC6	Piston rod and rod end nut made of stainless steel
-XC18	NPT finish piping port
-XC35	With coil scraper, ø32 to 100 only
-XC36	With boss in rod side
-X293	Same full length dimension as Series CQ1W
-X144	Change of port location
-X235	Change of piston rod end of double rod cylinder
-X271	Fluoro rubber for seals

Mounting Bracket Part No.

Bore size (mm)	Foot ⁽⁴⁾	Flange
12	CQ-L012	CQ-F012
16	CQ-L016	CQ-F016
20	CQ-L020	CQ-F020
25	CQ-L025	CQ-F025
32	CQ-L032	CQ-F032
40	CQ-L040	CQ-F040
50	CQ-L050	CQ-F050
63	CQ-L063	CQ-F063
80	CQ-L080	CQ-F080
100	CQ-L100	CQ-F100

Note 4) Order two foot brackets per cylinder.
Note 5) Parts belonging to each bracket are as follows.
Foot or Flange style: Body mounting bolt

Minimum Operating Pressure

(MPa)

Bore size (mm)	12	16	20	25	32	40	50	63	80	100
Pneumatic (Non-lube)	0.07	0.07	0.05	0.05	0.05	0.05	0.05	0.05	0.05	0.05
Air-hydro	—	—	0.18	0.18	0.18	0.10	0.10	0.10	0.10	0.10

Allowable Kinetic Energy

(J)

Bore size (mm)	12	16	20	25	32	40	50	63	80	100
Standard	0.022	0.038	0.055	0.09	0.15	0.26	0.46	0.77	1.36	2.27
With rubber bumper	0.043	0.075	0.11	0.18	0.29	0.52	0.91	1.54	2.71	4.54

Allowable Lateral Load at Rod End

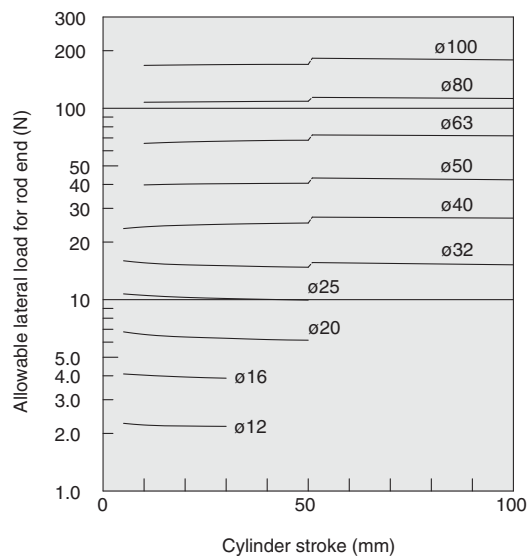

Allowable lateral load for rod end (Double rod, without switch)

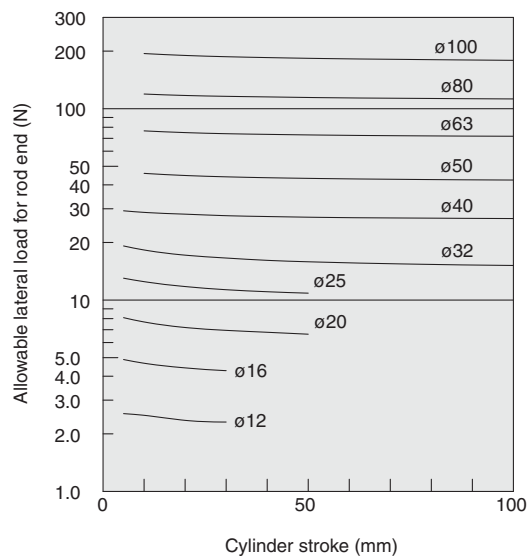

Allowable lateral load for rod end (Double rod, with switch)

CUJ

CU

CQS

CQM

CQ2

RQ

MU

D-

-X

20-

Data

Series CQ2W

Theoretical Output (N)

Bore size (mm)	Operating pressure (MPa)		
	0.3	0.5	0.7
12	25	42	59
16	45	75	106
20	71	118	165
25	113	189	264
32	181	302	422
40	317	528	739
50	495	825	1150
63	841	1400	1960
80	1360	2270	3170
100	2140	3570	5000

Weight (g)

Bore size (mm)	Cylinder stroke (mm)											
	5	10	15	20	25	30	35	40	45	50	75	100
12	42	49	56	63	70	77	—	—	—	—	—	—
16	59	68	77	86	95	104	—	—	—	—	—	—
20	89	104	119	134	149	164	179	194	209	224	—	—
25	119	136	153	170	187	204	221	238	255	272	—	—
32	192	220	244	268	292	316	340	364	388	412	532	652
40	292	323	354	385	416	447	478	509	540	571	726	881
50	—	528	573	618	663	708	753	798	843	888	1113	1338
63	—	676	714	753	792	831	870	909	948	987	1182	1377
80	—	1241	1325	1409	1493	1577	1661	1745	1829	1913	2333	2753
100	—	2106	2225	2344	2463	2582	2701	2820	2939	3058	3653	4248

Mounting Bolt for CQ2WB

Mounting method: Mounting bolt for through-hole mounting style of CQ2WB is available as an option.

Ordering: Add the word "Bolt" in front of the bolts to be used.

Example) Bolt M3 x 35ℓ 4 pcs.

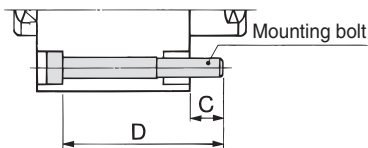

Additional Weight (g)

Bore size (mm)	12	16	20	25	32	40	50	63	80	100		
Both ends tapped style	2	2	6	6	6	6	6	19	45	45		
Rod end male thread	Male thread		3	6	12	24	52	54	106	106	240	350
	Nut		2	4	8	16	34	34	64	64	98	232
With rubber bumper	0	0	-2	-2	-3	-7	-12	-20	-34	-57		
Built-in One-touch fittings	—	—	—	—	12	12	21	21	—	—		
Foot style (Including mounting bolt)	57	71	170	195	159	171	267	349	735	1117		
Flange style (Including bolt)	57	69	139	161	180	214	373	559	1056	1365		

Calculation: (Example) CQ2WF32-20DCM

- Cylinder weight: CQ2WB32-20D 268 g
 - Option weight: Both ends tapped style 6 g
 - Rod end male thread 86 g
 - Rubber bumper -3 g
 - Flange style 180 g
- 537 g

Model	C	D	Bolt
CQ2WB12-5D	8.3	35	M3 x 35ℓ
-10D		40	x 40ℓ
-15D		45	x 45ℓ
-20D		50	x 50ℓ
-25D		55	x 55ℓ
-30D		60	x 60ℓ
CQ2WB16-5D	7.5	35	M3 x 35ℓ
-10D		40	x 40ℓ
-15D		45	x 45ℓ
-20D		50	x 50ℓ
-25D		55	x 55ℓ
-30D		60	x 60ℓ
CQ2WB20-5D	6	30	x 30ℓ
-10D		35	x 35ℓ
-15D		40	x 40ℓ
-20D		45	x 45ℓ
-25D		50	x 50ℓ
-30D		55	x 55ℓ
-35D		60	x 60ℓ
-40D		65	x 65ℓ
-45D		70	x 70ℓ
-50D		75	x 75ℓ
CQ2WB25-5D	8	35	M5 x 35ℓ
-10D		40	x 40ℓ
-15D		45	x 45ℓ
-20D		50	x 50ℓ
-25D		55	x 55ℓ
-30D		60	x 60ℓ
-35D		65	x 65ℓ
-40D		70	x 70ℓ
-45D		75	x 75ℓ
-50D		80	x 80ℓ

Model	C	D	Bolt
CQ2WB32-5D	6.5	35	M5 x 35ℓ
-10D		40	x 40ℓ
-15D		45	x 45ℓ
-20D		50	x 50ℓ
-25D		55	x 55ℓ
-30D		60	x 60ℓ
-35D		65	x 65ℓ
-40D		70	x 70ℓ
-45D		75	x 75ℓ
-50D		80	x 80ℓ
CQ2WB40-5D	7	45	M5 x 45ℓ
-10D		50	x 50ℓ
-15D		55	x 55ℓ
-20D		60	x 60ℓ
-25D		65	x 65ℓ
-30D		70	x 70ℓ
-35D		75	x 75ℓ
-40D		80	x 80ℓ
-45D		85	x 85ℓ
-50D		90	x 90ℓ
CQ2WB50-10D	12.5	55	M6 x 55ℓ
-15D		60	x 60ℓ
-20D		65	x 65ℓ
-25D		70	x 70ℓ
-30D		75	x 75ℓ
-35D		80	x 80ℓ
-40D		85	x 85ℓ
-45D		90	x 90ℓ
-50D		95	x 95ℓ
-75D		130	x 130ℓ
-100D	155	x 155ℓ	

Model	C	D	Bolt
CQ2WB63-10D	13.5	55	M8 x 55ℓ
-15D		60	x 60ℓ
-20D		65	x 65ℓ
-25D		70	x 70ℓ
-30D		75	x 75ℓ
-35D		80	x 80ℓ
-40D		85	x 85ℓ
-45D		90	x 90ℓ
-50D		95	x 95ℓ
-75D		130	x 130ℓ
CQ2WB80-10D	12.5	60	M10 x 60ℓ
-15D		65	x 65ℓ
-20D		70	x 70ℓ
-25D		75	x 75ℓ
-30D		80	x 80ℓ
-35D		85	x 85ℓ
-40D		90	x 90ℓ
-45D		95	x 95ℓ
-50D		100	x 100ℓ
-100D		160	x 160ℓ
CQ2WB100-10D	13	70	M10 x 70ℓ
-15D		75	x 75ℓ
-20D		80	x 80ℓ
-25D		85	x 85ℓ
-30D		90	x 90ℓ
-35D		95	x 95ℓ
-40D		100	x 100ℓ
-45D		105	x 105ℓ
-50D		110	x 110ℓ
-75D		145	x 145ℓ
-100D	170	x 170ℓ	

Compact Cylinder: Standard Type Double Acting, Double Rod Series CQ2W

Construction

Basic style

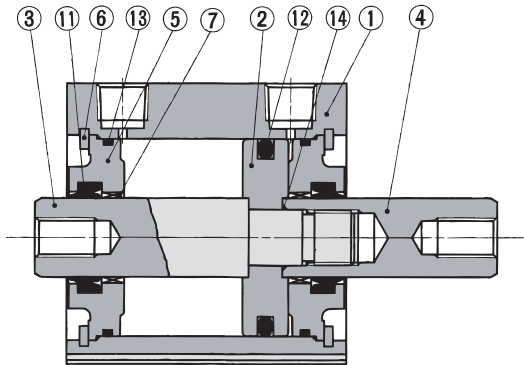

With rubber bumper

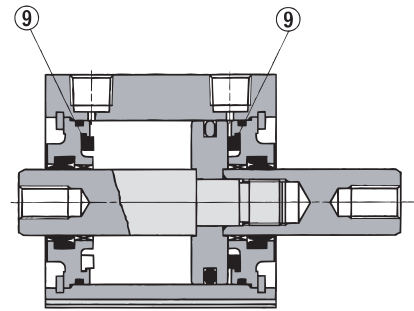

Built-in One-touch fittings

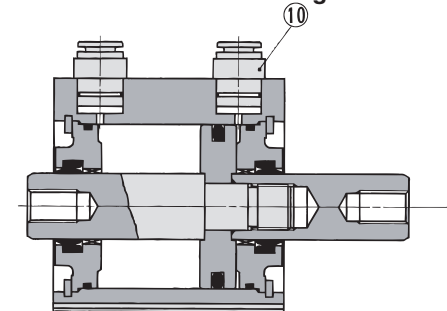

Rod end male thread

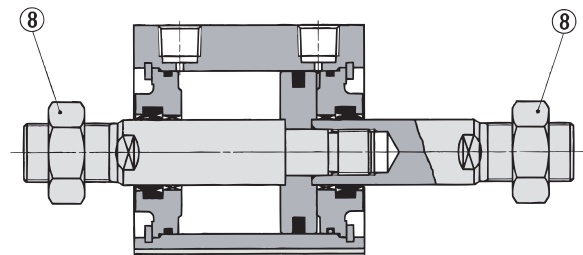

Component Parts

No.	Description	Material	Note
①	Cylinder tube	Aluminum alloy	Hard anodized
②	Piston	Aluminum alloy	Chromated
③	Piston rod A	Stainless steel	ø12 to ø25
		Carbon steel	ø32 to ø100, Hard chrome plated
④	Piston rod B	Stainless steel	ø12 to ø25
		Carbon steel	ø32 to ø100, Hard chrome plated
⑤	Collar	Aluminum alloy	ø12 to ø40, Anodized
		Aluminum alloy casted	ø50 to ø100, Chromated, painted
⑥	Snap ring	Carbon tool steel	Phosphate coated
⑦	Bushing	Lead bronze casting	For ø50 or larger only
⑧	Rod end nut	Carbon steel	Nickel plated
⑨	Bumper	Urethane	
⑩	One-touch fittings	—	ø32 to ø63
⑪*	Rod seal	NBR	
⑫*	Piston seal	NBR	
⑬*	Tube gasket	NBR	
⑭	Piston gasket	NBR	

Replacement Part: Seal Kit (Pneumatic)

Bore size (mm)	Kit no.	Contents
12	CQ2WB12-PS	Set of nos. above ⑪, ⑫, ⑬
16	CQ2WB16-PS	
20	CQ2WB20-PS	
25	CQ2WB25-PS	
32	CQ2WB32-PS	
40	CQ2WB40-PS	
50	CQ2WB50-PS	
63	CQ2WB63-PS	
80	CQ2WB80-PS	
100	CQ2WB100-PS	

Replacement Part: Seal Kit (Air-hydro)

Bore size (mm)	Kit no.	Contents
20	CQ2WBH20-PS	Set of nos. above ⑪, ⑫, ⑬
25	CQ2WBH25-PS	
32	CQ2WBH32-PS	
40	CQ2WBH40-PS	
50	CQ2WBH50-PS	
63	CQ2WBH63-PS	
80	CQ2WBH80-PS	
100	CQ2WBH100-PS	

* Seal kit includes ⑪, ⑫, ⑬. Order the seal kit, based on each bore size.

Copper-free (For CRT manufacturing process)

20 — CQ2WB **Bore size** — **Stroke** D(C)(M)
 • Copper-free • ø12, ø16, ø20, ø25, ø32, ø40, ø50, ø63, ø80, ø100

To prevent the influence of copper ions or halogen ions during CRT manufacturing processes, copper and fluorine materials are not used in the component parts.

Specifications

Action	Double acting, Double rod
Bore size (mm)	12, 16, 20, 25, 32, 40, 50, 63, 80, 100
Proof pressure	1.5 MPa
Maximum operating pressure	1.0 MPa
Rubber bumper	None
Piping	Screw-in piping
Piston speed	50 to 500 mm/s
Mounting	Through-hole
Auto switch	Mountable

CUJ

CU

CQS

CQM

CQ2

RQ

MU

D-

-X

20-

Data

Standard: Double Acting, Double Rod Series **CDQ2W** With Auto Switch



* Refer to page 7-9-1 for further information on auto switches.

How to Order

For "How to Order" with auto switch, refer to page 7-6-25.

Minimum Stroke for Auto Switch Mounting

(mm)

No. of auto switches mounted	D-F7□V D-J79C D-M9□V	D-A7□ D-A80 D-A73C D-A80C D-A9□V	D-F7□WV D-F9□WV D-F7BAVL	D-A7□H D-A80H D-F7□ D-J79 D-M9□ D-F9□W	D-A79W	D-F7□W D-J79W D-F7BAL D-F79F D-F9BAL	D-P5DWL	D-A9□
1 pc.	5	5	10	15	15	20	30	10
2 pcs.	5	10	15	15	20	20	30	10

Weight

(g)

Bore size (mm)	Cylinder stroke (mm)											
	5	10	15	20	25	30	35	40	45	50	75	100
12	55	63	71	79	87	95	—	—	—	—	—	—
16	88	99	110	121	132	143	—	—	—	—	—	—
20	135	152	169	186	203	220	237	254	271	288	—	—
25	182	199	216	233	250	267	284	301	318	335	—	—
32	247	271	295	319	343	367	391	415	439	463	487	511
40	370	401	432	463	494	525	556	587	618	649	680	711
50	—	647	692	737	782	827	872	917	962	1007	1052	1097
63	—	833	872	911	950	989	1028	1067	1106	1145	1184	1223
80	—	1500	1584	1668	1752	1836	1920	2004	2088	2172	2256	2340
100	—	2501	2620	2739	2858	2977	3096	3215	3334	3453	3572	3691

Additional Weight

(g)

	Bore size (mm)										
	12	16	20	25	32	40	50	63	80	100	
Both ends tapped style	1	1	3	3	6	6	6	19	45	45	
Rod end male thread	Male thread	3	6	12	24	52	54	106	106	240	350
	Nut	2	4	8	16	34	34	64	64	98	232
With rubber bumper	0	0	-2	-2	-3	-7	-12	-19	-34	-54	
Built-in One-touch fittings	—	—	—	—	12	12	21	21	—	—	
Foot style (Including mounting bolt)	52	65	153	177	159	171	267	349	735	1117	
Flange style (Including mounting bolt)	54	67	131	153	180	214	373	559	1056	1365	

Calculation:

(Example) CDQ2WF32-20DCM

• Cylinder weight: CDQ2WB32-20D ... 319 g

• Option weight: Both ends tapped style.....6 g

Rod end male thread86 g

Rubber bumper-3 g

Rod side flange style180 g

588 g

If auto switches are to be installed, the weight that corresponds to the number of auto switches and mounting brackets to be used must be added.

Auto Switch Mounting Bracket Weight

Mounting bracket part no.	Applicable bore (mm)	Weight (g)
BQ-1	12 to 25	1.5
BQ-2	32 to 100	1.5

* For the auto switch weight, refer to page 7-9-1.

Construction

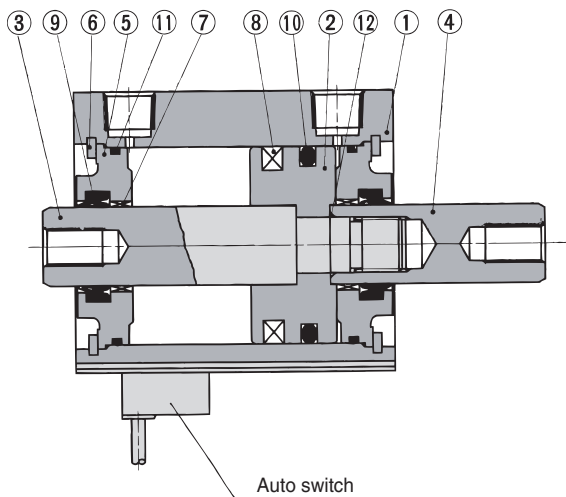

Component Parts

No.	Description	Material	Note
①	Cylinder tube	Aluminum alloy	Hard anodized
②	Piston	Aluminum alloy	Chromated
③	Piston rod A	Stainless steel	ø12 to ø25
		Carbon steel	ø32 to ø100, Hard chrome plated
④	Piston rod B	Stainless steel	ø12 to ø25
		Carbon steel	ø32 to ø100, Hard chrome plated
⑤	Collar	Aluminum alloy	ø12 to ø40, Anodized
		Aluminum alloy casted	ø50 to ø100, Chromated, painted
⑥	Snap ring	Carbon tool steel	Phosphate coated
⑦	Bushing	Lead-bronze casted	For ø50 or larger only
⑧	Magnet	—	—
⑨*	Rod seal	NBR	
⑩*	Piston seal	NBR	
⑪*	Tube gasket	NBR	
⑫	Piston gasket	NBR	

Replacement Parts: Seal Kit (Pneumatic)

Bore size (mm)	Kit no.	Contents
12	CQ2WB12-PS	Set of nos. above ⑨, ⑩, ⑪
16	CQ2WB16-PS	
20	CQ2WB20-PS	
25	CQ2WB25-PS	
32	CQ2WB32-PS	
40	CQ2WB40-PS	
50	CQ2WB50-PS	
63	CQ2WB63-PS	
80	CQ2WB80-PS	
100	CQ2WB100-PS	

* Seal kits includes ⑨, ⑩, ⑪. Order the seal kit, based on each bore size.

Replacement Parts: Seal Kit (Air-hydro)

Bore size (mm)	Kit no.	Contents
20	CQ2WBH20-PS	Set of nos. above ⑨, ⑩, ⑪
25	CQ2WBH25-PS	
32	CQ2WBH32-PS	
40	CQ2WBH40-PS	
50	CQ2WBH50-PS	
63	CQ2WBH63-PS	
80	CQ2WBH80-PS	
100	CQ2WBH100-PS	

* Seal kits includes ⑨, ⑩, ⑪. Order the seal kit, based on each bore size.

Compact Cylinder with Auto Switch: Standard Type Double Acting, Double Rod Series **CDQ2W**

Mounting Bolt for CDQ2 with Auto Switch

Mounting method: Mounting bolt for through-hole mounting style of CDQ2WB is available as an option.

Ordering: Add the word "Bolt" in front of the bolts to be used.

Example) Bolt M3 x 40ℓ 4 pcs.

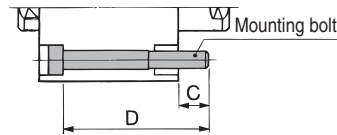

Model	C	D	Bolt
CDQ2WB12-5DC	6.1	40	M3 x 40ℓ
-10DC		45	x 45ℓ
-15DC		50	x 50ℓ
-20DC		55	x 55ℓ
-25DC		60	x 60ℓ
-30DC		65	x 65ℓ
CDQ2WB16-5D	7.5	45	M3 x 45ℓ
-10D		50	x 50ℓ
-15D		55	x 55ℓ
-20D		60	x 60ℓ
-25D		65	x 65ℓ
-30D		70	x 70ℓ
CDQ2WB20-5D	9	45	M5 x 45ℓ
-10D		50	x 50ℓ
-15D		55	x 55ℓ
-20D		60	x 60ℓ
-25D		65	x 65ℓ
-30D		70	x 70ℓ
-35D		75	x 75ℓ
-40D		80	x 80ℓ
-45D		85	x 85ℓ
-50D		90	x 90ℓ
CDQ2WB25-5D	8	45	M5 x 45ℓ
-10D		50	x 50ℓ
-15D		55	x 55ℓ
-20D		60	x 60ℓ
-25D		65	x 65ℓ
-30D		70	x 70ℓ
-35D		75	x 75ℓ
-40D		80	x 80ℓ
-45D		85	x 85ℓ
-50D		90	x 90ℓ

Model	C	D	Bolt
CDQ2WB32-5D	6.5	45	M5 x 45ℓ
-10D		50	x 50ℓ
-15D		55	x 55ℓ
-20D		60	x 60ℓ
-25D		65	x 65ℓ
-30D		70	x 70ℓ
-35D		75	x 75ℓ
-40D		80	x 80ℓ
-45D		85	x 85ℓ
-50D		90	x 90ℓ
CDQ2WB40-5D	7	55	M5 x 55ℓ
-10D		60	x 60ℓ
-15D		65	x 65ℓ
-20D		70	x 70ℓ
-25D		75	x 75ℓ
-30D		80	x 80ℓ
-35D		85	x 85ℓ
-40D		90	x 90ℓ
-45D		95	x 95ℓ
-50D		100	x 100ℓ
CDQ2WB50-10D	12.5	125	M6 x 125ℓ
-100D		150	x 150ℓ
-15D		65	M6 x 65ℓ
-20D		70	x 70ℓ
-25D		75	x 75ℓ
-30D		80	x 80ℓ
-35D		85	x 85ℓ
-40D		90	x 90ℓ
-45D		95	x 95ℓ
-50D		100	x 100ℓ
-75D	105	x 105ℓ	
-100D	130	x 130ℓ	
-100D	155	x 155ℓ	

Model	C	D	Bolt
CDQ2WB63-10D	13.5	65	M8 x 65ℓ
-15D		70	x 70ℓ
-20D		75	x 75ℓ
-25D		80	x 80ℓ
-30D		85	x 85ℓ
-35D		90	x 90ℓ
-40D		95	x 95ℓ
-45D		100	x 100ℓ
-50D		105	x 105ℓ
-75D		130	x 130ℓ
CDQ2WB80-10D	12.5	70	M10 x 70ℓ
-15D		75	x 75ℓ
-20D		80	x 80ℓ
-25D		85	x 85ℓ
-30D		90	x 90ℓ
-35D		95	x 95ℓ
-40D		100	x 100ℓ
-45D		105	x 105ℓ
-50D		110	x 110ℓ
-75D		135	x 135ℓ
CDQ2WB100-10D	13	160	M10 x 160ℓ
-15D		80	M10 x 80ℓ
-20D		85	x 85ℓ
-25D		90	x 90ℓ
-30D		95	x 95ℓ
-35D		100	x 100ℓ
-40D		105	x 105ℓ
-45D		110	x 110ℓ
-50D		115	x 115ℓ
-75D		145	x 145ℓ
-100D	170	x 170ℓ	

CUJ

CU

CQS

CQM

CQ2

RQ

MU

D-

-X

20-

Data

Series CDQ2W

Proper Auto Switch Mounting Position (Detection at stroke end) and Its Mounting Height

D-A7□
D-A80

D-A7□H, D-A80H
D-F7□, D-J79
D-F7□W, D-J79W
D-F79F, D-F7NTL
D-F7BAL

D-A73C
D-A80C
D-J79C

D-A79W
D-F7□WV
D-F7□V
D-F7BAVL

ø12 to ø25

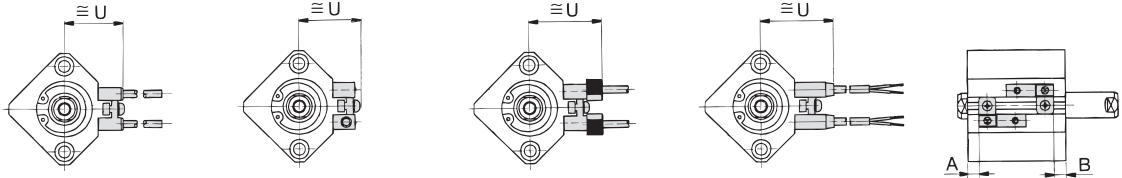

ø32 to ø100

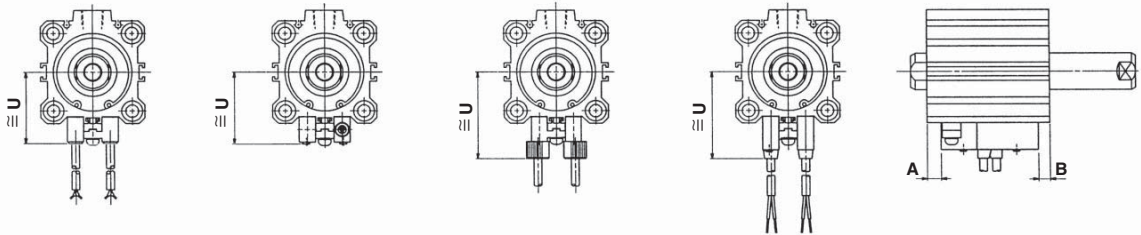

D-A9□
D-M9□, D-F9□W

D-A9□V
D-M9□V
D-F9□WV

D-F9BAL

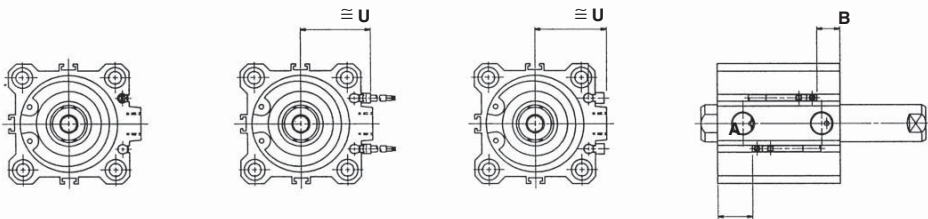

ø40 to ø100

D-P5DWL

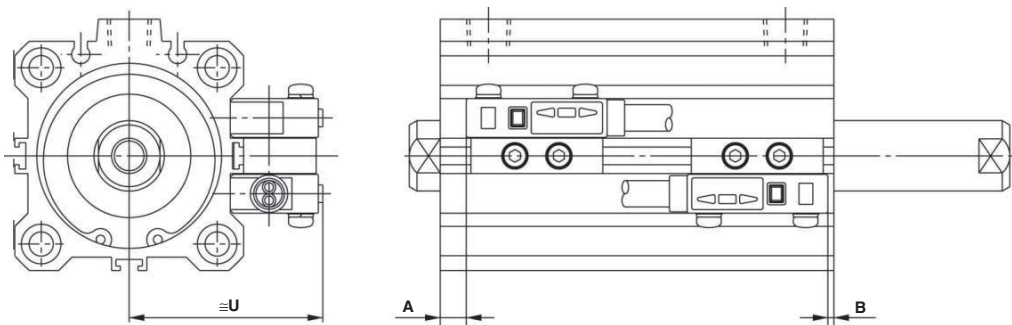

Compact Cylinder with Auto Switch: Standard Type Double Acting, Double Rod Series **CDQ2W**

Proper Auto Switch Mounting Position

Bore size (mm)	D-A7□/A80		D-F7□H/A80H D-A73C/A80C D-F7□/J79/J79W D-F7□V/J79C D-F7□W/F7□WV D-F7BAL/F7BAVL D-F79F		D-A79W		D-A9□ D-A9□V		D-M9□ D-M9□V D-F9□W D-F9□WV		D-F9BAL		D-P5DWL	
	A	B	A	B	A	B	A	B	A	B	A	B	A	B
12	4.5	10	5	10.5	2	7.5	—	—	—	—	—	—	—	—
16	7.5	10.5	8	11	5	8	—	—	—	—	—	—	—	—
20	7.5	13	8	13.5	5	10.5	—	—	—	—	—	—	—	—
25	7.5	13	8	13.5	5	10.5	—	—	—	—	—	—	—	—
32	9	13.5	9.5	14	6.5	11	8	12.5	12	16.5	11	15.5	—	—
40	13	19	13.5	19.5	10.5	16.5	12	18	16	22	15	21	9	15
50	11	21.5	11.5	22	8.5	19	10	20.5	14	24.5	13	23.5	7	17.5
63	13.5	20.5	14	21	11	18	12.5	19.5	16.5	23.5	15.5	22.5	9.5	16.5
80	17.5	29	18	29.5	15	26.5	16.5	28	20.5	32	19.5	31	13.5	25
100	21.0	31.5	—	32	18.5	29	20	30.5	24	34.5	23	33.5	17	27.5

Auto Switch Mounting Height

Bore size (mm)	D-A7□/A80	D-A7□H D-A80H D-F7□ D-J79 D-F7□W	D-J79W D-F9BAL D-F79F D-F7NTL	D-A73C D-A80C	D-F7□V D-F7□WV D-F7BAVL	D-J79C	D-A79W	D-A9□V	D-M9□V D-F9□WV	D-F9BAL	D-P5DWL
	U	U	U	U	U	U	U	U	U	U	U
12	19.5	20.5	26.5	23	26	22	—	—	—	—	—
16	22.5	23.5	29.5	26	29	25	—	—	—	—	—
20	24.5	25.5	31.5	28	31	27	—	—	—	—	—
25	27.5	28.5	34.5	31	34	30	—	—	—	—	—
32	31.5	32.5	38.5	35	38	34	27	29	26.5	—	—
40	35	36	42	38.5	41.5	37.5	30.5	32.5	30	44	—
50	41	42	48	44.5	47.5	43.5	36.5	38.5	36	50	—
63	47.5	48.5	54.5	51	54	50	42	39.5	39.5	56.5	—
80	57.5	58.5	64.5	61	64	60	50	52	49.5	66.5	—
100	67.5	68.5	74.5	71	74	70	60	62	59.5	76.5	—

CUJ

CU

CQS

CQM

CQ2

RQ

MU

D-

-X

20-

Data

Series CQ2W

Dimensions: $\phi 12$ to $\phi 25$ /Without Auto Switch

Basic style (Through-hole): CQ2WB

Both ends tapped style: CQ2WA

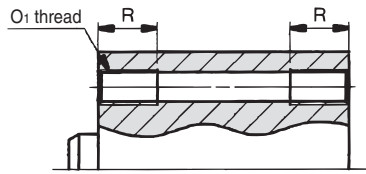

Both Ends Tapped Style

Bore size (mm)	O ₁	R
12	M4 x 0.7	7
16	M4 x 0.7	7
20	M6 x 1.0	10
25	M6 x 1.0	10

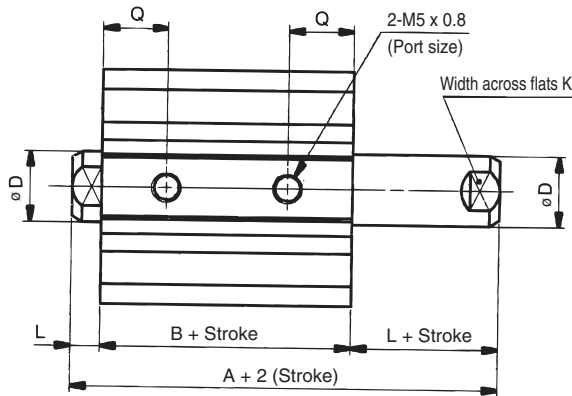
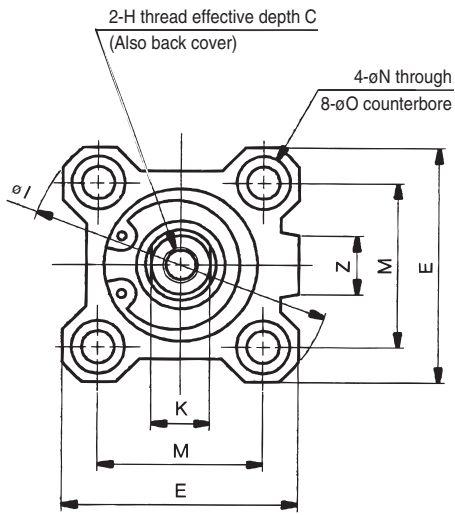

Rod End Male Thread

Bore size (mm)	A ₁	C ₁	H ₁	L ₁	X
12	53.2	9	M5 x 0.8	14	10.5
16	57	10	M6 x 1.0	15.5	12
20	63	12	M8 x 1.25	18.5	14
25	74	15	M10 x 1.25	22.5	17.5

Rod end male thread

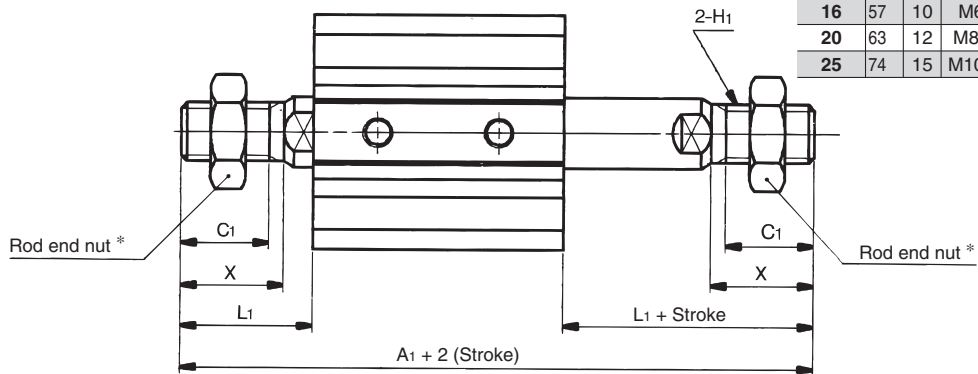

Basic Style

Bore size (mm)	Stroke range (mm)	A	B	C	D	E	H	I	K	L	M	N	O	Q	Z
12	5 to 30	32.2	25.2	6	6	25	M3 x 0.5	32	5	3.5	15.5	3.5	6.5 depth 3.5	10	—
16	5 to 30	33	26	8	8	29	M4 x 0.7	38	6	3.5	20	3.5	6.5 depth 3.5	10	10
20	5 to 50	35	26	7	10	36	M5 x 0.8	47	8	4.5	25.5	5.5	9 depth 7	9.5	10
25	5 to 50	39	29	12	12	40	M6 x 1.0	52	10	5	28	5.5	9 depth 7	11	10

Note) External dimensions with rubber bumper are same as standard type as shown above.

* For details about the rod end nut and accessory brackets, refer to page 7-6-20.

Compact Cylinder: Standard Type Double Acting, Double Rod Series CQ2W

Foot style: CQ2WL

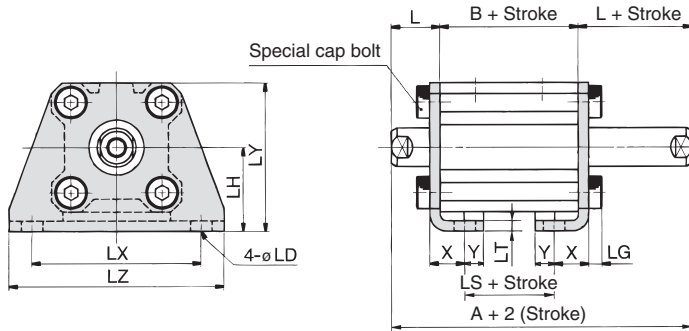

Rod end male thread

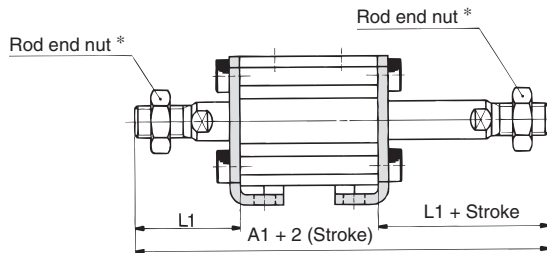

Rod End Male Thread

Bore size (mm)	A1	L1
12	73.2	24
16	77	25.5
20	83	28.5
25	94	32.5

Foot Style

Bore size (mm)	Stroke range (mm)	A	B	L	LD	LG	LH	LS	LT	LX	LY	LZ	X	Y
12	5 to 30	52.2	25.2	13.5	4.5	2.8	17	13.2	2	34	29.5	44	8	4.5
16	5 to 30	53	26	13.5	4.5	2.8	19	14	2	38	33.5	48	8	5
20	5 to 50	55	26	14.5	6.6	4	24	14	3.2	48	42	62	9.2	5.8
25	5 to 50	59	29	15	6.6	4	26	14	3.2	52	46	66	10.7	5.8

Foot bracket material: Carbon steel

Flange style: CQ2WF

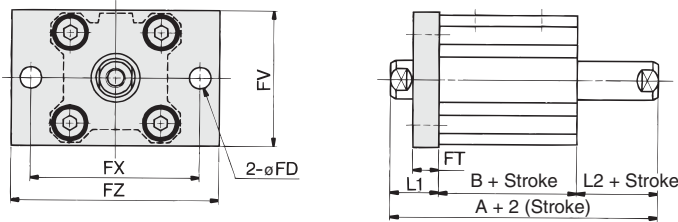

Rod end male thread

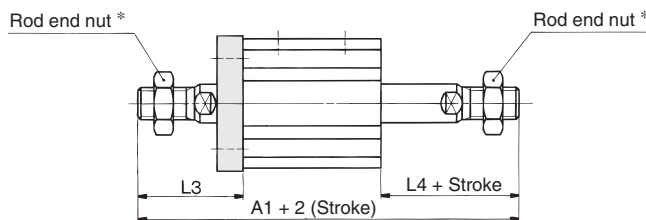

Rod End Male Thread

Bore size (mm)	A1	L3	L4
12	63.2	24	14
16	67	25.5	15.5
20	73	28.5	18.5
25	84	32.5	22.5

Flange Style

Bore size (mm)	Stroke range (mm)	A	B	FD	FT	FV	FX	FZ	L1	L2
12	5 to 30	42.2	25.2	4.5	5.5	25	45	55	13.5	3.5
16	5 to 30	43	26	4.5	5.5	30	45	55	13.5	3.5
20	5 to 50	45	26	6.6	8	39	48	60	14.5	4.5
25	5 to 50	49	29	6.6	8	42	52	64	15	5

* For details about the rod end nut and accessory brackets, refer to page 7-6-20.

Flange bracket material: Carbon steel

CUJ
CU
CQS
CQM
CQ2
RQ
MU
D-
-X
20-
Data

Series CQ2W

Dimensions: $\phi 12$ to $\phi 25$ /With Auto Switch

Basic style (Through-hole): CDQ2WB

Both ends tapped style: CDQ2WA

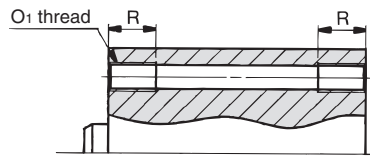

Both Ends Tapped Style

Bore size (mm)	O1	R
12	M4 x 0.7	7
16	M4 x 0.7	7
20	M6 x 1.0	10
25	M6 x 1.0	10

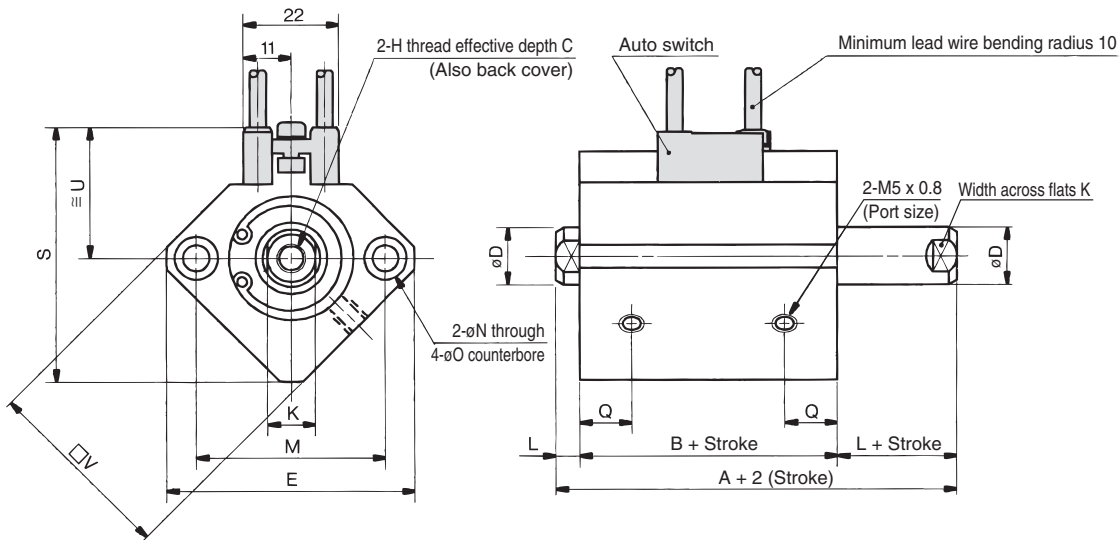

Rod end male thread

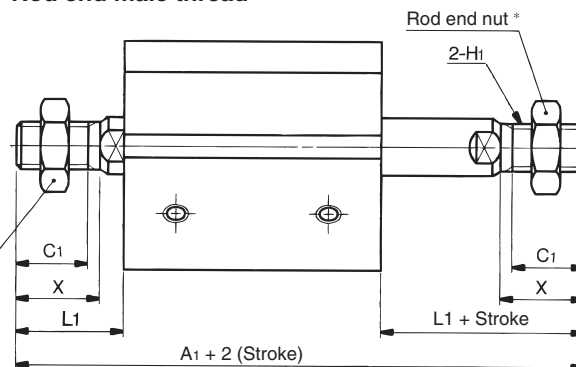

Rod End Male Thread

Bore size (mm)	A1	C1	H1	L1	X
12	60.4	9	M5 x 0.8	14	10.5
16	67	10	M6 x 1.0	15.5	12
20	75	12	M8 x 1.25	18.5	14
25	84	15	M10 x 1.25	22.5	17.5

Auto switch shown above is D-A73 and D-A80. For auto switch mounting position and its mounting height, refer to page 7-6-22.

Basic Style

Bore size (mm)	Stroke range (mm)	A	B	C	D	E	H	K	L	M	N	O	Q	S	U	V
12	5 to 30	39.4	32.4	6	6	32	M3 x 0.5	5	3.5	22	3.5	6.5 depth 3.5	10.5	35.5	19.5	25
16	5 to 30	43	36	8	8	38	M4 x 0.7	6	3.5	28	3.5	6.5 depth 3.5	10	41.5	22.5	29
20	5 to 50	47	38	7	10	47	M5 x 0.8	8	4.5	36	5.5	9 depth 7	10.5	48	24.5	36
25	5 to 50	49	39	12	12	52	M6 x 1.0	10	5	40	5.5	9 depth 7	11	53.5	27.5	40

Note) External dimensions with rubber bumper are same as standard type as shown above.

* For details about the rod end nut and accessory brackets, refer to page 7-6-20.

Compact Cylinder: Standard Type Double Acting, Double Rod Series CQ2W

Foot style: CDQ2WL

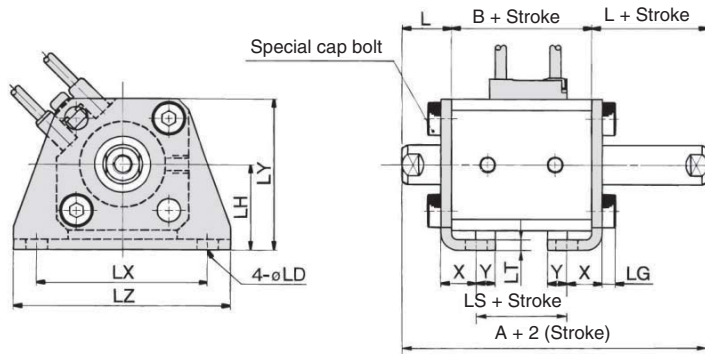

Rod end male thread

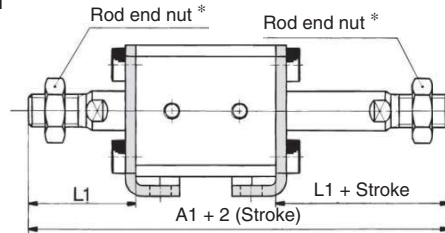

Rod End Male Thread

Bore size (mm)	A1	L1
12	80.4	24
16	87	25.5
20	95	28.5
25	104	32.5

Foot Style

Bore size (mm)	Stroke range (mm)	A	B	L	LD	LG	LH	LS	LT	LX	LY	LZ	X	Y
12	5 to 30	59.4	32.4	13.5	4.5	2.8	17	20.4	2	34	29.5	44	8	4.5
16	5 to 30	63	36	13.5	4.5	2.8	19	24	2	38	33.5	48	8	5
20	5 to 50	67	38	14.5	6.6	4	24	26	3.2	48	42	62	9.2	5.8
25	5 to 50	69	39	15	6.6	4	26	24	3.2	52	46	66	10.7	5.8

Foot bracket material: Carbon steel

Flange style: CDQ2WF

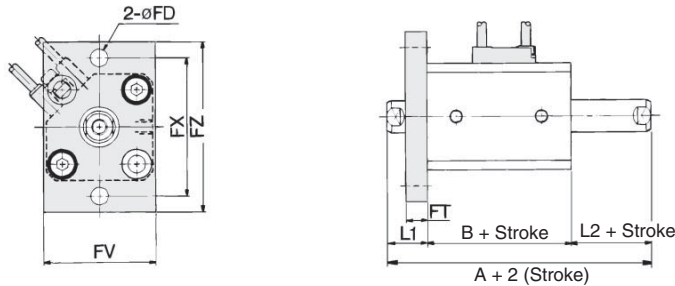

Rod end male thread

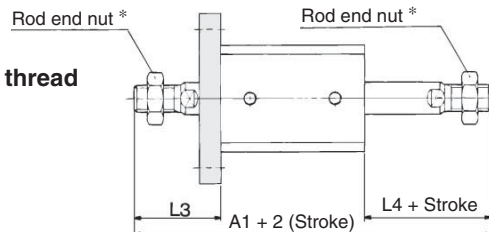

Rod End Male Thread

Bore size (mm)	A1	L3	L4
12	70.4	24	14
16	77	25.5	15.5
20	85	28.5	18.5
25	94	32.5	22.5

Flange Style

Bore size (mm)	Stroke range (mm)	A	B	FD	FT	FV	FX	FZ	L1	L2
12	5 to 30	49.4	32.4	4.5	5.5	25	45	55	13.5	3.5
16	5 to 30	53	36	4.5	5.5	30	45	55	13.5	3.5
20	5 to 50	57	38	6.6	8	39	48	60	14.5	4.5
25	5 to 50	59	39	6.6	8	42	52	64	15	5

* For details about the rod end nut and accessory brackets, refer to page 7-6-20.

Flange bracket material: Carbon steel

Series CQ2W/CDQ2W

(In the case of without auto switches, A, B and P dimensions will be only changed. Refer to the dimension table.)

Dimensions: ø32 to ø50/With Auto Switch

Basic style (Through-hole): CQ2WB/CDQ2WB

Both ends tapped style: CQ2WA

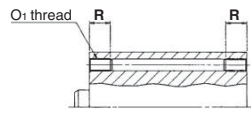

Both Ends Tapped Style

Bore size (mm)	O ₁	R
32	M6 x 1.0	10
40	M6 x 1.0	10
50	M8 x 1.25	14

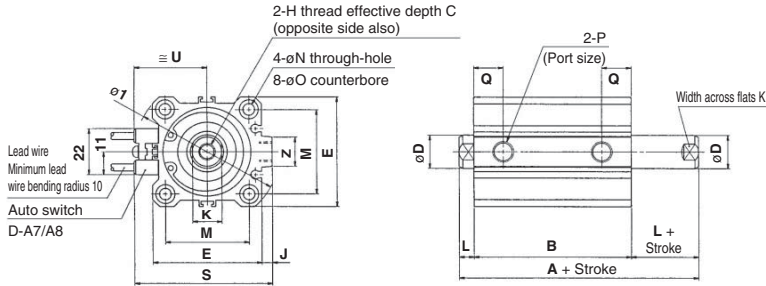

Rod end male thread

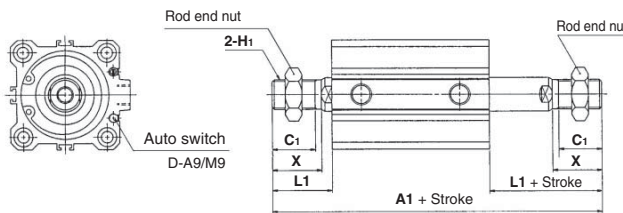

Rod End Male Thread

Bore size (mm)	Without auto switch			With auto switch		
	A1			A1		
	50 st or less	55 to 75	80 to 100	50 st or less	55 to 75	80 to 100
32	87.5 + Stroke	172.5	197.5	97.5 + Stroke	172.5	197.5
40	97 + Stroke	182	207	107 + Stroke	182	207
50	107.5 + Stroke	192.5	217.5	117.5 + Stroke	192.5	217.5

Built-in One-touch fittings: ø32 to ø50

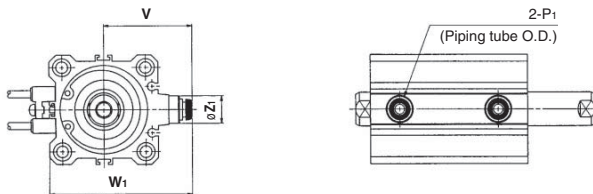

Bore size (mm)	C ₁	H ₁	L ₁	X
32	20.5	M14 x 1.5	28.5	23.5
40	20.5	M14 x 1.5	28.5	23.5
50	26	M18 x 1.5	33.5	28.5

Auto switch shown above is D-A73 type and D-A80 type. For the auto switch mounting position and its mounting height, refer to page 7-6-22.

Built-in One-touch Fittings

Bore size (mm)	Without auto switch		With auto switch		Z ₁	P ₁
	V	W ₁	V	W ₁		
32	38	60.5	36.5	59	13	6
40	42	68	40.5	66.5	13	6
50	50	82	50	82	16	8

Basic Style

Bore size (mm)	Without auto switch								With auto switch						
	A			B			P		A			B			P
	50 st or less	55 to 75	80 to 100	50 st or less	55 to 75	80 to 100	5 st	10 to 100	50 st or less	55 to 75	80 to 100	50 st or less	55 to 75	80 to 100	5 to 100 st
32	44.5 + Stroke	129.5	154.5	30.5 + Stroke	115.5	140.5	M5 x 0.8	Rc 1/8	54.5 + Stroke	129.5	154.5	40.5 + Stroke	115.5	140.5	Rc 1/8
40	54 + Stroke	139	164	40 + Stroke	125	150	Rc 1/8	Rc 1/8	64 + Stroke	139	164	50 + Stroke	125	150	Rc 1/8
50	56.5 + Stroke	141.5	166.5	40.5 + Stroke	125.5	150.5	Rc 1/4	Rc 1/4	66.5 + Stroke	141.5	166.5	50.5 + Stroke	125.5	150.5	Rc 1/4

Bore size (mm)	C	D	E	H	I	J	K	L	M	N	O	Q	S	U	Z
32	13	16	45	M8 x 1.25	60	4.5	14	7	34	5.5	9 depth 7	12.5	58.5	31.5	14
40	13	16	52	M8 x 1.25	69	5	14	7	40	5.5	9 depth 7	14	66	35	14
50	15	20	64	M10 x 1.5	86	7	17	8	50	6.6	11 depth 8	14	80	41	19

Note) External dimensions with rubber bumper are same as standard type as shown above.

* For details about the rod end nut and accessory brackets, refer to page 7-6-20.

Note) When obtaining the full length dimension of 50 stroke or less, it requires to add the stroke twice.

Example) Full length dimension = A + Stroke
= (●● + Stroke) + Stroke

Compact Cylinder: Standard Type Double Acting, Double Rod Series CQ2W/CDQ2W

Foot style: CQ2WL/CDQ2WL

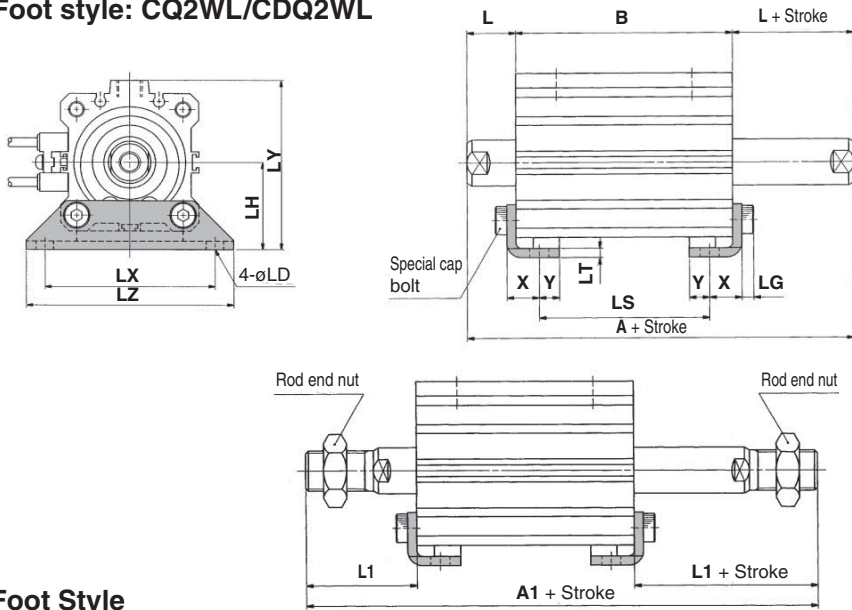

Rod End Male Thread

Bore size (mm)	Without auto switch			With auto switch			L1
	A1			A1			
	50 st or less	55 to 75	80 to 100	50 st or less	55 to 75	80 to 100	
32	107.5 + Stroke	192.5	217.5	117.5 + Stroke	192.5	217.5	38.5
40	117 + Stroke	202	227	127 + Stroke	202	227	38.5
50	127.5 + Stroke	212.5	237.5	137.5 + Stroke	212.5	237.5	43.5

Foot Style

Bore size (mm)	Stroke range (mm)	Without auto switch									With auto switch								
		A			B			LS			A			B			LS		
		50 st or less	55 to 75	80 to 100	50 st or less	55 to 75	80 to 100	50 st or less	55 to 75	80 to 100	50 st or less	55 to 75	80 to 100	50 st or less	55 to 75	80 to 100	50 st or less	55 to 75	80 to 100
32	5 to 50, 75, 100	64.5 + Stroke	149.5	174.5	30.5 + Stroke	115.5	140.5	14.5 + Stroke	99.5	124.5	74.5 + Stroke	149.5	174.5	40.5 + Stroke	115.5	140.5	24.5 + Stroke	99.5	124.5
40	5 to 50, 75, 100	74 + Stroke	159	184	40 + Stroke	125	150	24 + Stroke	109	134	84 + Stroke	159	184	50 + Stroke	125	150	34 + Stroke	109	134
50	10 to 50, 75, 100	76.5 + Stroke	161.5	186.5	40.5 + Stroke	125.5	150.5	17.5 + Stroke	102.5	127.5	86.5 + Stroke	161.5	186.5	50.5 + Stroke	125.5	150.5	27.5 + Stroke	102.5	127.5

Foot bracket material: Carbon steel

Bore size (mm)	L	LD	LG	LH	LT	LX	LY	LZ	X	Y
32	17	6.6	4	30	3.2	57	57	71	11.2	5.8
40	17	6.6	4	33	3.2	64	64	78	11.2	7
50	18	9	5	39	3.2	79	78	95	14.7	8

Flange style: CQ2WF/CDQ2WF

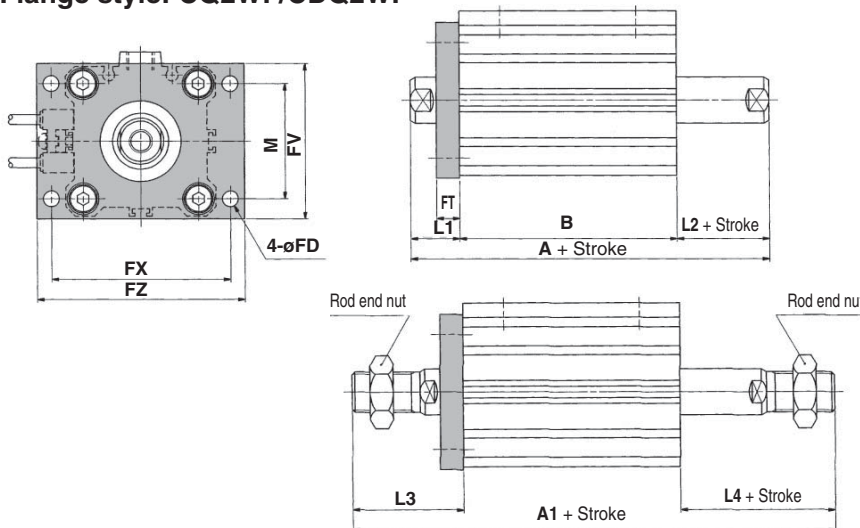

Rod End Male Thread

Bore size (mm)	Without auto switch			With auto switch			L3	L4
	A1			A1				
	50 st or less	55 to 75	80 to 100	50 st or less	55 to 75	80 to 100		
32	97.5 + Stroke	182.5	207.5	107.5 + Stroke	182.5	207.5	38.5	28.5
40	107 + Stroke	202.5	217	117 + Stroke	192	217	38.5	28.5
50	117.5 + Stroke	204	227.5	127.5 + Stroke	202.5	227.5	43.5	33.5

Flange Style

Bore size (mm)	Stroke range (mm)	Without auto switch									With auto switch									FD	FT	FV	FX	FZ	L1	L2	M
		A			B			A			B																
		50 st or less	55 to 75	80 to 100	50 st or less	55 to 75	80 to 100	50 st or less	55 to 75	80 to 100	50 st or less	55 to 75	80 to 100														
32	5 to 50, 75, 100	54.5 + Stroke	139.5	164.5	30.5 + Stroke	115.5	140.5	64.5 + Stroke	139.5	164.5	40.5 + Stroke	115.5	140.5	5.5	8	48	56	65	17	7	34						
40	5 to 50, 75, 100	64 + Stroke	149	174	40 + Stroke	125	150	74 + Stroke	149	174	50 + Stroke	125	150	5.5	8	54	62	72	17	7	40						
50	10 to 50, 75, 100	66.5 + Stroke	151.5	176.5	40.5 + Stroke	125.5	150.5	76.5 + Stroke	151.5	176.5	50.5 + Stroke	125.5	150.5	6.6	9	67	76	89	18	8	50						

Flange bracket material: Carbon steel

Note) When obtaining the full length dimension of 50 stroke or less, it requires to add the stroke twice.
Example) Full length dimension = A + Stroke = (● + Stroke) + Stroke

CUJ

CU

CQS

CQM

CQ2

RQ

MU

D-

-X

20-

Data

Series CQ2W/CDQ2W

(In the case of without auto switches, A and B dimensions will be only changed. Refer to the dimension table.)

Dimensions: $\phi 63$ to $\phi 100$ /With Auto Switch

Basic style (Through-hole): CQ2WB/CDQ2WB

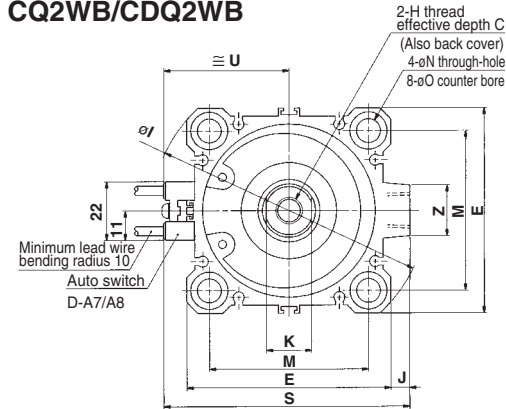

Both ends tapped style: CQ2WA/CDQ2WA

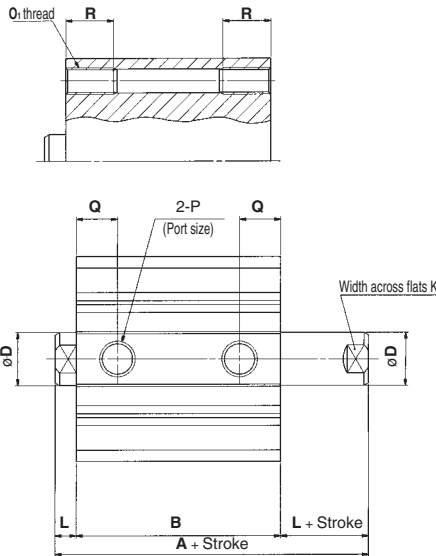

Both Ends Tapped Style

Bore size (mm)	O ₁	R
63	M10 x 1.5	18
80	M12 x 1.75	22
100	M12 x 1.75	22

Rod end male thread

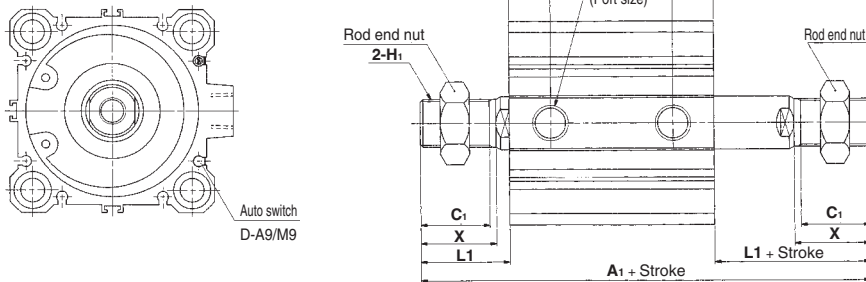

Rod End Male Thread

Bore size (mm)	Without auto switch			With auto switch		
	A1			A1		
	50 st or less	55 to 75	80 to 100	50 st or less	55 to 75	80 to 100
63	109 + Stroke	194	219	119 + Stroke	194	219
80	138 + Stroke	223	248	148 + Stroke	223	248
100	147.5 + Stroke	232.5	257.5	157.5 + Stroke	232.5	257.5

Bore size (mm)	C1	H1	L1	X
63	26	M18 x 1.5	33.5	28.5
80	32.5	M22 x 1.5	43.5	35.5
100	32.5	M26 x 1.5	43.5	35.5

Built-in One-touch fittings

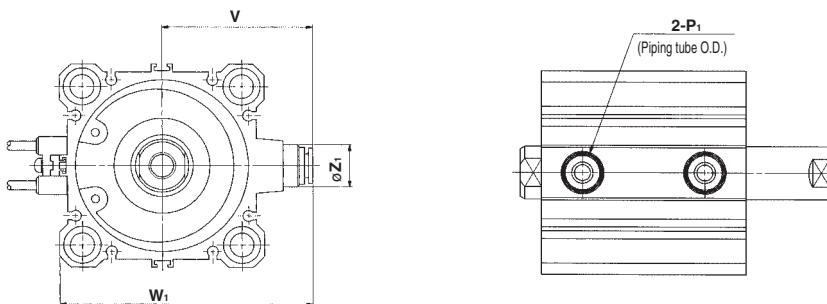

Auto switch shown above is D-A73 type and D-A80 type. For the auto switch mounting position and its mounting height, refer to page 7-6-22.

Built-in One-touch Fittings

Bore size (mm)	Z ₁	P ₁	V	W ₁
63	16	8	56.5	95

* In the case of built-in One-touch fitting, the 5 mm stroke with $\phi 32$ bore is the same external dimensions as 10 mm stroke.

Basic Style

Bore size (mm)	Stroke range (mm)	Without auto switch						With auto switch					
		A			B			A			B		
		50 st or less	55 to 75	80 to 100	50 st or less	55 to 75	80 to 100	50 st or less	55 to 75	80 to 100	50 st or less	55 to 75	80 to 100
63	10 to 50, 75, 100	58 + Stroke	143	168	42 + Stroke	127	152	68 + Stroke	143	168	52 + Stroke	127	152
80	10 to 50, 75, 100	71 + Stroke	156	181	51 + Stroke	136	161	81 + Stroke	156	181	61 + Stroke	136	161
100	10 to 50, 75, 100	84.5 + Stroke	169.5	194.5	60.5 + Stroke	145.5	170.5	94.5 + Stroke	169.5	194.5	70.5 + Stroke	145.5	170.5

Bore size (mm)	C	D	E	H	I	J	K	L	M	N	O	P	Q	S	U	Z
63	15	20	77	M10 x 1.5	103	7	17	8	60	9	14 depth 10.5	Rc 1/4	15.5	93	47.5	19
80	21	25	98	M16 x 2.0	132	6	22	10	77	11	17.5 depth 13.5	Rc 3/8	18	112.5	57.5	26
100	27	30	117	M20 x 2.5	156	6.5	27	12	94	11	17.5 depth 13.5	Rc 3/8	22	132.5	67.5	26

Note 1) External dimensions with rubber bumper are same as standard type as shown above.

* For details about the rod end nut and accessory brackets, refer to page 7-6-20.

Note 2) When obtaining the full length dimension of 50 stroke or less, it requires to add the stroke twice.

Example) Full length dimension = A + Stroke = (●● + Stroke) + Stroke

Compact Cylinder: Standard Type Double Acting, Double Rod Series **CQ2W/CDQ2W**

Foot style: CQ2W/CDQ2WL

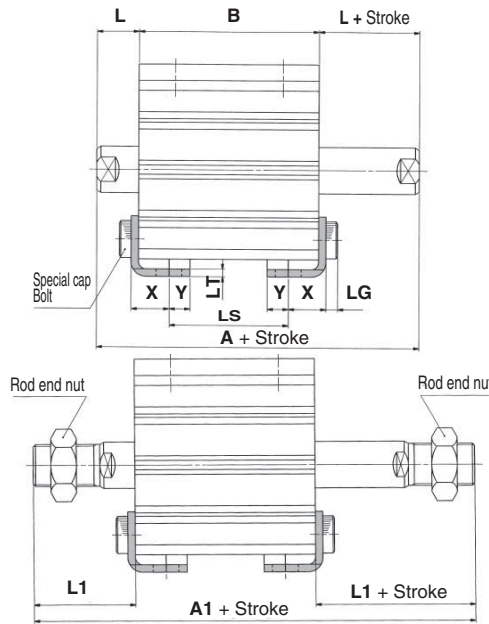
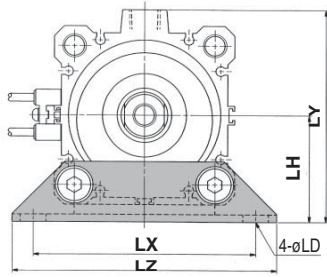

Rod End Male Thread

Bore size (mm)	Without auto switch			With auto switch			L1
	A1			A1			
	50 st or less	55 to 75	80 to 100	50 st or less	55 to 75	80 to 100	
63	129 + Stroke	214	239	139 + Stroke	214	239	43.5
80	158 + Stroke	243	268	168 + Stroke	243	268	53.5
100	167.5 + Stroke	252.5	277	177.5 + Stroke	252.5	277.5	53.5

Foot Style

Bore size (mm)	Stroke range (mm)	Without auto switch									With auto switch								
		A			B			LS			A			B			LS		
		50 st or less	55 to 75	80 to 100	50 st or less	55 to 75	80 to 100	50 st or less	55 to 75	80 to 100	50 st or less	55 to 75	80 to 100	50 st or less	55 to 75	80 to 100	50 st or less	55 to 75	80 to 100
63	5 to 50, 75, 100	78 + Stroke	163	188	42 + Stroke	127	152	16 + Stroke	101	126	88 + Stroke	163	188	52 + Stroke	127	152	26 + Stroke	101	126
80	5 to 50, 75, 100	91 + Stroke	176	201	51 + Stroke	136	161	21 + Stroke	106	131	101 + Stroke	176	201	61 + Stroke	136	161	31 + Stroke	106	131
100	10 to 50, 75, 100	104.5 + Stroke	189.5	214.5	60.5 + Stroke	145.5	170.5	26.5 + Stroke	111.5	136.5	114.5 + Stroke	189.5	214.5	70.5 + Stroke	145.5	170.5	36.5 + Stroke	111.5	136.5

Foot bracket material: Carbon steel

Bore size (mm)	L	LD	LG	LH	LT	LX	LY	LZ	X	Y
63	18	11	5	46	3.2	95	91.5	113	16.2	9
80	20	13	7	59	4.5	118	114	140	19.5	11
100	22	13	7	71	6	137	136	162	23	12.5

Flange style: CQ2WF/CDQ2WF

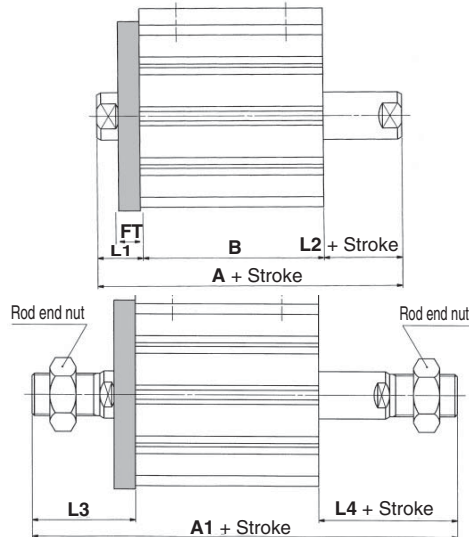
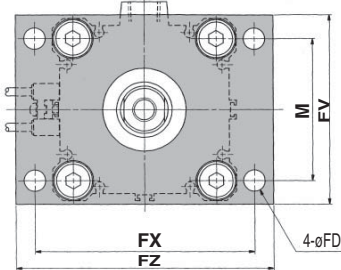

Rod End Male Thread

Bore size (mm)	Without auto switch			With auto switch			L3	L4
	A1			A1				
	50 st or less	55 to 75	80 to 100	50 st or less	55 to 75	80 to 100		
63	119 + Stroke	204	229	129 + Stroke	204	229	43.5	33.5
80	148 + Stroke	233	258	158 + Stroke	233	258	53.5	43.5
100	157.5 + Stroke	242.5	267.5	167.5 + Stroke	242.5	267.5	53.5	43.5

Flange Style

Bore size (mm)	Stroke range (mm)	Without auto switch									With auto switch									FD	FT	FV	FX	FZ	L1	L2	M
		A			B			A			B																
		50 st or less	55 to 75	80 to 100	50 st or less	55 to 75	80 to 100	50 st or less	55 to 75	80 to 100	50 st or less	55 to 75	80 to 100														
32	10 to 50, 75, 100	68 + Stroke	153	178	42 + Stroke	127	152	78 + Stroke	153	178	52 + Stroke	127	152	9	9	80	92	108	18	8	60						
40	10 to 50, 75, 100	81 + Stroke	166	191	51 + Stroke	136	161	91 + Stroke	166	191	61 + Stroke	136	161	11	11	99	116	134	20	10	77						
50	10 to 50, 75, 100	94.5 + Stroke	179.5	204.5	60.5 + Stroke	145.5	170.5	104.5 + Stroke	179.5	204.5	70.5 + Stroke	145.5	170.5	11	11	117	136	154	22	12	94						

Flange bracket material: Carbon steel

Note) When obtaining the full length dimension of 50 stroke or less, it requires to add the stroke twice.
Example) Full length dimension = A + Stroke = (● + Stroke) + Stroke



Compact Cylinder: Standard Type

Single Acting, Single Rod, Spring Return/Extend

Series CQ2

ø12, ø16, ø20, ø25, ø32, ø40, ø50

How to Order

Without auto switch

CQ2 **B** **20** **□** **10** **S** **□**

With auto switch

CDQ2 **B** **20** **□** **10** **S** **□** **J79W** **S**

Number of auto switches

Nil	2 pcs.
S	1 pc.
n	"n" pcs.

Auto switch

Nil	Without auto switch (Built-in magnet)
-----	---------------------------------------

Body option

Nil	Standard (Rod end female thread)
F	With boss in head side
M	Rod end male thread

Action

S	Single acting, Spring return
T	Single acting, Spring extend

Cylinder stroke (mm)

Refer to "Standard Stroke" on page 7-6-43.

Built-in magnet

Mounting style

B	Through-hole (Standard)	F	Rod side flange style
A	Both ends tapped style	G	Head side flange style
L	Foot style	D	Double clevis style

* Mounting brackets are shipped together, (but not assembled).

Bore size

12	12 mm
16	16 mm
20	20 mm
25	25 mm
32	32 mm
40	40 mm
50	50 mm

Piping

Nil	Screw-in piping
F	Built-in One-touch fittings (Note)

Note) Bore sizes available w/ One-touch fittings are ø32 to ø50.

Applicable Auto Switch/Refer to page 7-9-1 for further information on auto switches.

Type	Special function	Electrical entry	Indicator light	Wiring (Output)	Load voltage		Rail mounting		Direct mounting		Lead wire length (m) *				Pre-wire connector	Applicable load								
					DC	AC	ø12 to ø50		ø32 to ø50		0.5 (Nil)	3 (L)	5 (Z)	None (N)		IC circuit	Relay, PLC							
							Perpendicular	In-line	Perpendicular	In-line														
Reed switch	—	Grommet	Yes	3-wire (NPN equivalent)	—	5 V	—	A76H	A96V	A96	●	●	—	—	—	IC circuit	—							
											—	—	200 V	A72				A72H	—	—	●	●	—	—
	Diagnostic indication (2-color indication)	Connector		2-wire	24 V	12 V	100 V	—	—	A93V	A93	●	●	—	—	—	Relay, PLC							
								—	—	A73C	—	—	—	●	●			●	●	—				
Solid state switch	—	Grommet	Yes	3-wire (NPN)	—	5 V, 12 V	—	F7NV	F79	M9NV	M9N	●	●	○	—	○	IC circuit							
												3-wire (PNP)	F7PV	F7P	M9PV			M9P	●	●	○	—	○	
		Diagnostic indication (2-color indication)		Connector	2-wire	24 V	12 V	—	—	—	—	—	—	●	●	○	—	—	Relay, PLC					
								—	—	—	—	—	—	●	●	●	●			—				
	Water resistant (2-color indication)	Grommet		2-wire	24 V	5 V, 12 V	—	12 V	—	F7NWW	F79W	F9NWW	F9NW	●	●	○	—	○	IC circuit					
														—	F7PW	F9PWW	F9PW			●	●	○	—	○
														—	F7BWW	F9BWW	F9BW			●	●	○	—	○
														—	F7BAV	—	F9BA			—	●	○	—	○
With diagnostic output (2-color indication)	Grommet	4-wire (NPN)	24 V	5 V, 12 V	—	12 V	—	—	—	—	—	●	●	○	—	○	IC circuit							
—																		F79F	—	—	—	—	—	—

* Lead wire length symbols: 0.5 m.....Nil (Example) A73C
 3 m.....L (Example) A73CL
 5 m.....Z (Example) A73CZ
 None.....N (Example) A73CN

* Solid state switches marked with "○" are produced upon receipt of order.

• Since there are other applicable auto switches than listed, refer to page 7-6-23 for details.
 • For details about auto switches with pre-wire connector, refer to page 7-9-36.

Compact Cylinder: Standard Type Single Acting, Single Rod, Spring Return/Extend Series CQ2



JIS Symbol

Single acting,
Spring return

Single acting,
Spring extend

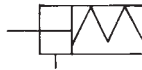
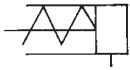

⚠ Precautions

Be sure to read before handling.
For Safety Instructions and Actuator Precautions, refer to pages 7-13-3 to 7-13-6.

⚠ Caution

Snap Ring Installation/Removal

- For installation and removal, use an appropriate pair of pliers (tool for installing a type C snap ring).
- Even if a proper plier (tool for installing type C snap ring) is used, it is likely to inflict damage to a human body or peripheral equipment, as a snap ring may be flown out of the tip of a plier (tool for installing a type C snap ring). Be much careful with the popping of a snap ring. Besides, be certain that a snap ring is placed firmly into the groove of rod cover before supplying air at the time of installment.

Mounting Bracket Part No.

Bore size (mm)	Foot (2)	Flange	Double (3) clevis
12	CQ-L012	CQ-F012	CQ-D012
16	CQ-L016	CQ-F016	CQ-D016
20	CQ-L020	CQ-F020	CQ-D020
25	CQ-L025	CQ-F025	CQ-D025
32	CQ-L032	CQ-F032	CQ-D032
40	CQ-L040	CQ-F040	CQ-D040
50	CQ-L050	CQ-F050	CQ-D050

Note 2) When ordering foot bracket, order 2 pieces per cylinder.

Note 3) Parts belonging to each bracket are as follows.
Foot, Flange/Body mounting bolt, Double clevis/Clevis pin, Type C snap ring for axis, Body mounting bolt

Type

Bore size (mm)		12	16	20	25	32	40	50	
Pneumatic	Mounting	Through-hole (Standard)	●	●	●	●	●	●	
		Both ends tapped style	●	●	●	●	●	●	
	Built-in magnet		●	●	●	●	●	●	
	Piping	Screw-in type	M5 x 0.8	M5 x 0.8	M5 x 0.8	M5 x 0.8	M5 x 0.8 Rc 1/8 (Note)	Rc 1/8	Rc 1/4
		Built-in One-touch fittings	—	—	—	—	ø6/4	ø6/4	ø8/6
	Rod end male thread		●	●	●	●	●	●	●
With boss in head side		●	●	●	●	●	●	●	

Note) In the case of without auto switch, M5 x 0.8 is used for 5 stroke only.

Specifications

Type	Pneumatic (Non-lube)
Fluid	Air
Proof pressure	1.5 MPa
Maximum operating pressure	1.0 MPa
Ambient and fluid temperature	Without auto switch: -10 to 70°C (No freezing) With auto switch: -10 to 60°C (No freezing)
Rubber bumper	None
Rod end thread	Female thread
Rod end thread tolerance	JIS Class 2
Stroke length tolerance	+1.0 0
Mounting	Through-hole
Piston speed	50 to 500 mm/s

Standard Stroke

Bore size (mm)	Standard stroke
12, 16, 20 25, 32, 40	5, 10
50	10, 20

Manufacture of Intermediate Stroke (Single acting, Spring retract type is excluded.)

Description	Spacer is installed in the standard stroke body.	
Part no.	Refer to "How to Order" for the standard model no. on page 7-6-42.	
Description	Dealing with the stroke by the 1 mm interval is available by installing spacer with standard stroke cylinder.	
Stroke range	Bore size	Stroke range
	12 to 40	1 to 9
	50	1 to 19
Example	Part no.: CQ2B20-3T CQ2B20-5T with 2 mm width spacer inside. B dimension is 24.5 mm.	

Allowable Kinetic Energy

(J)

Bore size (mm)	12	16	20	25	32	40	50
Allowable kinetic energy	0.022	0.038	0.055	0.09	0.15	0.26	0.46

CUJ

CU

CQS

CQM

CQ2

RQ

MU

D-

-X

20-

Data

Series CQ2



Made to Order Specifications (For details, refer to page 7-10-1.)

Symbol	Specifications
-XA□	Change of rod end shape, S type only
-XB10	Intermediate stroke (Using exclusive body)
-XC6	Piston rod and rod end nut made of stainless steel
-XC18	NPT finish piping port
-XC36	With boss in rod side, Type T only
-X202	Same full length dimension as Series CQ1 Except ø12, 16, 25
-X203	Same L dimension from rod cover as Series CQ1
-X271	Fluoro rubber for seals

Minimum Operating Pressure (MPa)

Bore size (mm)	Single acting (Spring return/extend)
12	0.25
16	0.25
20	0.18
25	0.18
32	0.17
40	0.15
50	0.13

Theoretical Output (N)

Action	Bore size (mm)	Operating pressure (MPa)		
		0.3	0.5	0.7
Spring return	12	21	44	66
	16	45	86	126
	20	79	142	205
	25	126	224	323
	32	211	372	533
	40	338	589	841
	50	535	928	1316
Spring extend	12	14	31	48
	16	24	54	85
	20	44	91	138
	25	84	160	235
	32	152	273	393
	40	288	499	710
50	412	742	1072	

For the spring force, refer to page 7-12-3.

Compact Cylinder: Standard Type Single Acting, Single Rod, Spring Return/Extend Series CQ2

Weight

Action	Bore size (mm)	Cylinder stroke (mm)			
		5	10	15	20
Spring return	12	29	35	—	—
	16	42	51	—	—
	20	63	76	—	—
	25	87	101	—	—
	32	131	152	—	—
	40	206	229	—	—
	50	—	369	—	441
Spring extend	12	29	35	—	—
	16	43	50	—	—
	20	67	78	—	—
	25	92	104	—	—
	32	141	158	—	—
	40	216	235	—	—
	50	—	399	—	460

Additional Weight

Bore size (mm)		12	16	20	25	32	40	50
Both ends tapped style		2	2	6	6	6	6	6
Rod end male thread	Male thread	1.5	3	6	12	26	27	53
	Nut	1	2	4	8	17	17	32
With boss in head side		0.7	1.3	2	3	5	7	13
Built-in One-touch fittings		—	—	—	—	6	6	10.5
Foot style (Including mounting bolt)		55	67	164	186	143	155	243
Rod side flange style (Including mounting bolt)		57	69	139	161	180	214	373
Rear flange style (Including mounting bolt)		54	65	133	152	165	198	348
Double clevis style (Including pin, snap ring, bolt)		32	39	88	123	151	196	393

Calculation: (Example) CQ2D32-10SM

- Cylinder weight: CQ2B32-10S..... 152 g
- Option weight: Both ends tapped style..... 6 g
- Rod end male thread..... 43 g
- Double clevis style..... 151 g
- 352 g

Auto Switch Mounting Bracket Part No.

Bore size (mm)	Mounting bracket part no.	Note	Applicable auto switch	
			Reed switch	Solid state switch
12, 16 20, 25	BQ-1	<ul style="list-style-type: none"> • Switch mounting screw (M3 x 0.5 x 8ℓ) • Square nut 	D-A7/A8 D-A73C/A80C D-A7□H/A80H D-A79W	D-F7□/J79 D-F7□V D-J79C D-F7□W/J79W D-F7□WV D-F7BAL D-F7BAVL D-F79F D-F7NTL
32, 40 50	BQ-2	<ul style="list-style-type: none"> • Switch mounting screw (M3 x 0.5 x 10ℓ) • Switch spacer • Switch mounting nut 		



[Mounting screws set made of stainless steel]
 The set of stainless steel mounting screws (with nuts) described below is available and can be used depending on the operating environment. (Since the spacer is not included, order it separately.)
 BBA2: For D-A7/A8/F7/J7
 D-F7BAL/F7BAVL switch is set on the cylinder with the stainless steel screws above when shipped.
 When only a switch is shipped independently, "BBA2" screws are attached.

Mounting Bolt for CQ2

Mounting method: Mounting bolt for through-hole mounting style of CQ2B is available as an option.

Ordering: Add the word "Bolt" in front of the bolts to be used.
 Example) Bolt M3 x 25ℓ 4 pcs.

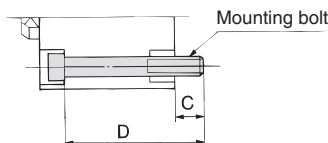

Spring Return

Model	C	D	Mounting bolt
CQ2B12-5S	6.5	25	M3 x 25ℓ
		30	x 30ℓ
CQ2B16-5S	5	25	M3 x 25ℓ
		30	x 30ℓ
CQ2B20-5S	7.5	25	M5 x 25ℓ
		30	x 30ℓ
CQ2B25-5S	9.5	30	M5 x 30ℓ
		35	x 35ℓ
CQ2B32-5S	9	30	M5 x 30ℓ
		35	x 35ℓ
CQ2B40-5S	7.5	35	M5 x 35ℓ
		40	x 40ℓ
CQ2B50-10S	12.5	45	M6 x 45ℓ
		55	x 55ℓ

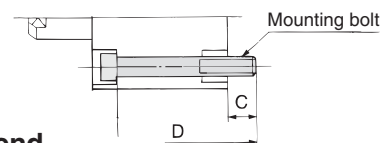

Spring Extend

Model	C	D	Mounting bolt
CQ2B12-5T	6.5	25	M3 x 25ℓ
		30	x 30ℓ
CQ2B16-5T	5	25	M3 x 25ℓ
		30	x 30ℓ
CQ2B20-5T	7.5	25	M5 x 25ℓ
		30	x 30ℓ
CQ2B25-5T	9.5	30	M5 x 30ℓ
		35	x 35ℓ
CQ2B32-5T	9	30	M5 x 30ℓ
		35	x 35ℓ
CQ2B40-5T	7.5	35	M5 x 35ℓ
		40	x 40ℓ
CQ2B50-10T	12.5	45	M6 x 45ℓ
		55	x 55ℓ

Series CQ2

Construction

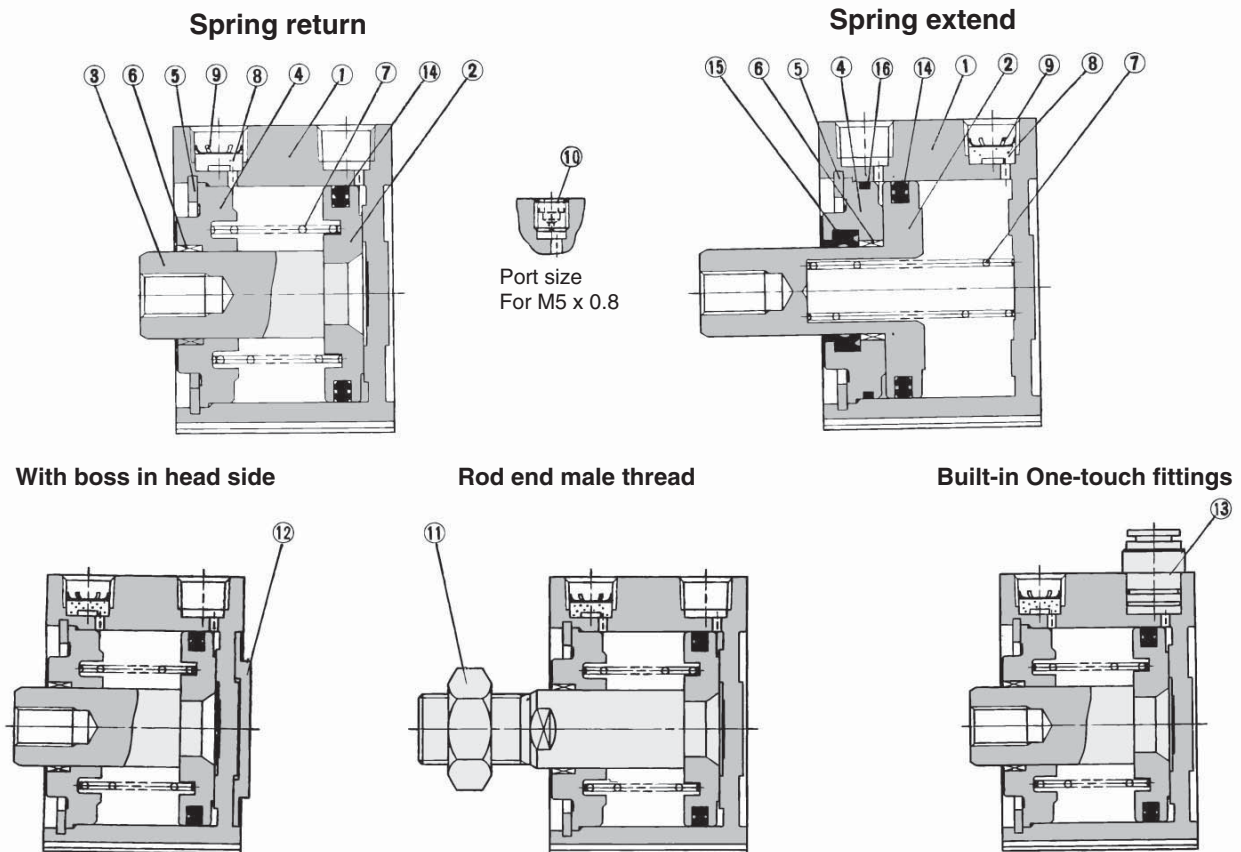

Component Parts

No.	Description	Material	Note
①	Cylinder tube	Aluminum alloy	Hard anodized
②*	Piston	Aluminum alloy	Chromated
③	Piston rod	Stainless steel	ø12 to ø25
		Carbon steel	ø32 to ø50, Hard chrome plated
④	Collar	Aluminum bearing alloy	ø12 to ø40, Anodized
		Aluminum alloy casted	ø50, Chromate, Painted
⑤	Snap ring	Carbon tool steel	Phosphate coated
⑥	Bushing	Lead-bronze casted	ø50, Spring return
		Lead bronze casted	ø50, Spring extend
⑦	Return spring	Piano wire	Zinc chromated
⑧	Bronze element	Sintered metallic BC	Port size Rc 1/8, 1/4
⑨	Snap ring	Carbon tool steel	
⑩	Plug with fixed orifice	Alloy steel	
⑪	Rod end nut	Carbon steel	Nickel plated
⑫	Centering location ring	Aluminum alloy	ø20 to ø50, Anodized
⑬	One-touch fitting	—	ø32 to ø50

* On spring extend (type T), piston and piston rod are integrated (stainless steel).

Replacement Parts

No.	Description	Material	Note
⑭	Piston seal	NBR	
⑮	Rod seal	NBR	
⑯	Gasket	NBR	

Replacement Parts: Seal Kit

Bore size (mm)	Single acting/Spring return	Single acting/Spring extend
12	CQ2B12-S-PS	CQ2B12-T-PS
16	CQ2B16-S-PS	CQ2B16-T-PS
20	CQ2B20-S-PS	CQ2B20-T-PS
25	CQ2B25-S-PS	CQ2B25-T-PS
32	CQ2B32-S-PS	CQ2B32-T-PS
40	CQ2B40-S-PS	CQ2B40-T-PS
50	CQ2B50-S-PS	CQ2B50-T-PS
Note	A set includes ⑭.	Kits include items ⑭, ⑮, ⑯ from the table above
How to order	* Seal kit includes ⑭. Order the seal kit, based on each bore size.	* Seal kit includes ⑭, ⑮, ⑯. Order the seal kit, based on each bore size.

Copper-free (For CRT manufacturing process)

20 — CQ2B Bore size — Stroke $\frac{S}{T}$ (M)
 • Copper-free — ø12, ø16, ø20, ø25, ø32, ø40, ø50

To prevent the influence of copper ions or halogen ions during CRT manufacturing processes, copper and fluorine materials are not used in the component parts.

Specifications

Action	Single acting, Single rod
Bore size (mm)	12, 16, 20, 25, 32, 40, 50
Proof pressure	1.5 MPa
Maximum operating pressure	1.0 MPa
Rubber bumper	None
Piping	Screw-in piping
Piston speed	50 to 500 mm/s
Mounting	Through-hole
Auto switch	Mountable

Standard Type: Single Acting, Single Rod

Series CDQ2

With Auto Switch

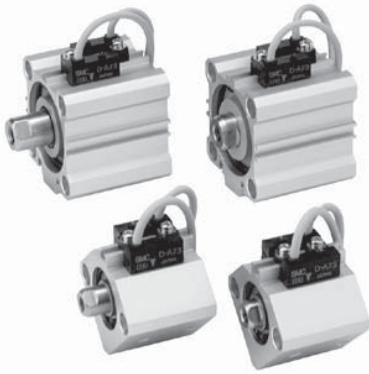

Minimum Stroke for Auto Switch Mounting (mm)

No. of auto switches mounted	D-F7□V D-J79C D-M9□V	D-A7□ D-A80 D-A73C D-A80C D-A9□V	D-F7□WV D-F9□WV D-F7BAVL	D-A7□H D-A80H D-F7□ D-J79 D-M9□ D-F9□W	D-A79W	D-F7□W D-J79W D-F7BAL D-F79F D-F9BAL	D-A9□
1 pc.	5	5	10	15	15	20	10
2 pcs.	5	10	15	15	20	20	10

Weight (g)

Action	Bore size (mm)	Cylinder stroke (mm)			
		5	10	15	20
Spring return	12	48	54	—	—
	16	74	83	—	—
	20	109	123	—	—
	25	146	162	—	—
	32	190	211	—	—
	40	282	305	—	—
Spring extend	12	53	70	—	—
	16	73	82	—	—
	20	122	133	—	—
	25	160	175	—	—
	32	200	217	—	—
	40	292	311	—	—
	50	—	517	—	578

Additional Weight (g)

Bore size (mm)	12	16	20	25	32	40	50		
Both ends tapped style	1	1	3	3	6	6	6		
Rod end	Male thread		1.5	3	6	12	26	27	53
	Nut		1	2	4	8	17	17	32
With boss in head side	0.7	1.3	2	3	5	7	13		
Built-in One-touch fittings	—	—	—	—	6	6	10.5		
Foot style (Including mounting bolt)	49	62	147	169	143	155	243		
Rod side flange style (Including mounting bolt)	54	67	131	153	180	214	373		
Rear flange style (Including mounting bolt)	52	63	124	144	165	198	348		
Double clevis style (Including pin, snap ring, bolt)	29	35	78	114	151	196	393		

Calculation: (Example) CDQ2D32-10SM

- Cylinder weight: CDQ2B32-10S 211 g
- Option weight: Both ends tapped style ... 6 g
- Rod end male thread ... 43 g
- Double clevis style 151 g

If auto switches are to be installed, the weight that corresponds to the number of auto switches and mounting brackets to be used must be added.

Auto Switch Mounting Bracket Weight

Mounting bracket part no.	Applicable bore (mm)	Weight (g)
BQ-1	12 to 25	1.5
BQ-2	32 to 50	1.5

* For the auto switch weight, refer to page 7-9-1.

Construction

Spring return

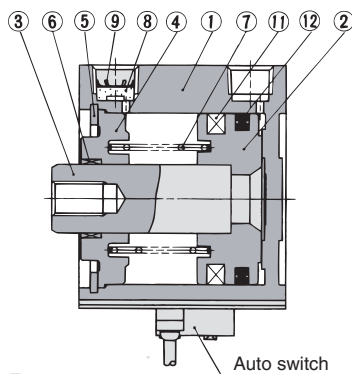

Spring extend

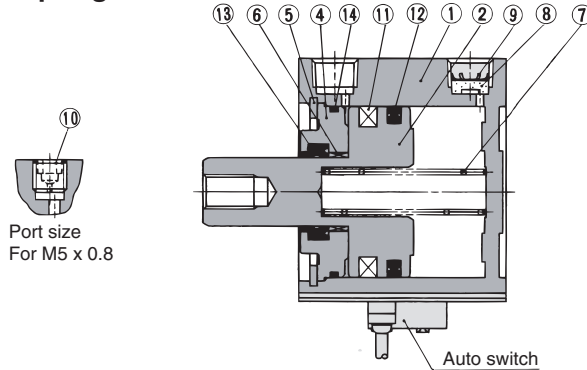

Component Parts

No.	Description	Material	Note
①	Cylinder tube	Aluminum alloy	Hard anodized
②	Piston	Aluminum alloy	Chromated
③	Piston rod	Stainless steel	ø12 to ø25
		Carbon steel	ø32 to ø50, Hard chrome plated
④	Collar	Aluminum alloy	ø12 to ø40, Anodized
		Aluminum alloy casted	ø50, Chromate, Painted
⑤	Snap ring	Carbon tool steel	Phosphate coated
⑥	Bushing	Lead-bronze casted	ø50, Spring return
		Lead bronze casted	ø50, Spring extend
⑦	Return spring	Piano wire	Zinc chromated
⑧	Bronze element	Sintered metallic BC	Port size Rc 1/8, 1/4.
⑨	Snap ring	Carbon tool steel	
⑩	Plug with fixed orifice	Alloy steel	Port size M5 x 0.8
⑪	Magnet	—	

* On spring extend (type T), piston with ø20 or more and piston rod are integrated (Stainless steel).

No.	Description	Material	Note
⑫	Piston seal	NBR	
⑬	Rod seal	NBR	
⑭	Gasket	NBR	



Replacement Parts: Seal Kit

Since the same as standard type, single acting, single rod, refer to page 7-6-46.

Series CDQ2

Mounting Bolt for CDQ2 with Auto Switch

Mounting method: Mounting bolt for through-hole mounting style of CDQ2B is available as an option.

Ordering: Add the word "Bolt" in front of the bolts to be used.

Example) Bolt M3 x 35ℓ 2 pcs.

Spring return

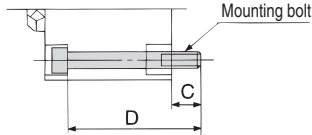

Spring extend

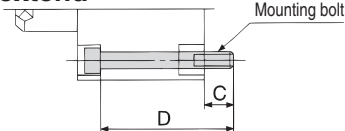

Spring Return

Model	C	D	Mounting bolt
CDQ2B12-5S	5.5	35	M3 x 35ℓ
-10S		40	x 40ℓ
CDQ2B16-5S	8	40	M3 x 40ℓ
-10S		45	x 45ℓ
CDQ2B20-5S	10.5	40	M5 x 40ℓ
-10S		45	x 45ℓ
CDQ2B25-5S	9.5	40	M5 x 40ℓ
-10S		45	x 45ℓ
CDQ2B32-5S	9	40	M5 x 40ℓ
-10S		45	x 45ℓ
CDQ2B40-5S	7.5	45	M5 x 45ℓ
-10S		50	x 50ℓ
CDQ2B50-10S	12.5	55	M6 x 55ℓ
-20S		65	x 65ℓ

Spring Extend

Model	C	D	Mounting bolt
CDQ2B12-5T	6.1	40	M3 x 40ℓ
-10T		45	x 45ℓ
CDQ2B16-5T	8	40	M3 x 40ℓ
-10T		45	x 45ℓ
CDQ2B20-5T	10.5	40	M5 x 40ℓ
-10T		45	x 45ℓ
CDQ2B25-5T	9.5	40	M5 x 40ℓ
-10T		45	x 45ℓ
CDQ2B32-5T	9	40	M5 x 40ℓ
-10T		45	x 45ℓ
CDQ2B40-5T	7.5	45	M5 x 45ℓ
-10T		50	x 50ℓ
CDQ2B50-10T	12.5	55	M6 x 55ℓ
-20T		65	x 65ℓ

Proper Auto Switch Mounting Position (Detection at stroke end) and Its Mounting Height

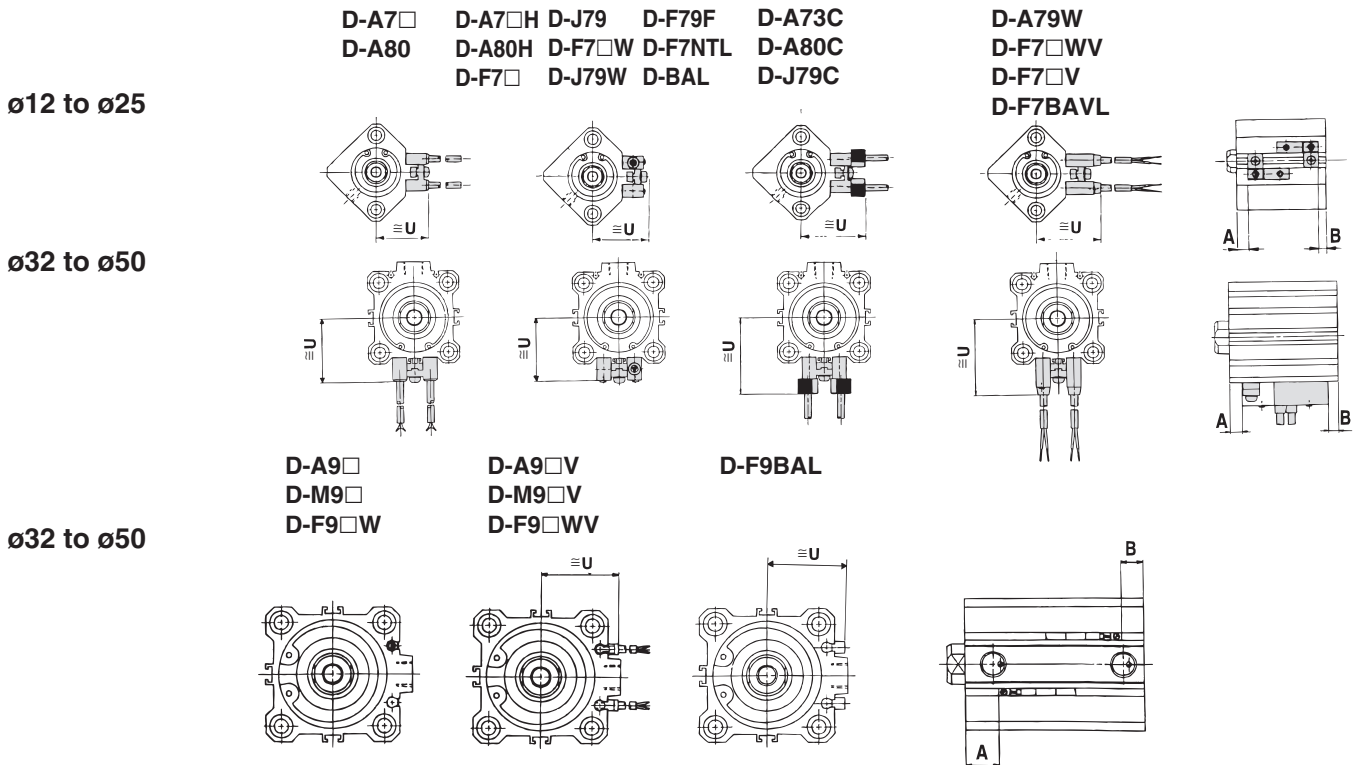

Proper Auto Switch Mounting Position

Bore size (mm)	D-A7□ D-A80		D-A7□H D-A80H D-A73C D-A80C D-F7□ D-F79F D-J79 D-F7□V D-J79C D-F7□W D-J79W D-F7□WV D-F7BAVL D-F7BAL		D-A79W		D-A9□ D-A9□V		D-M9□ D-M9□V D-F9□W D-F9□WV		D-F9BAL	
	A	B	A	B	A	B	A	B	A	B	A	B
12	4.5	5.5 (10)	5	6 (10.5)	2	3 (7.5)	—	—	—	—	—	—
16	7.5 (5.5)	5 (7)	8 (6)	5.5 (7.5)	5 (3)	2.5 (4.5)	—	—	—	—	—	—
20	7.5	6.5	8	7	5	4	—	—	—	—	—	—
25	7.5	7	8	7.5	5	4.5	—	—	—	—	—	—
32	9	6	9.5	6.5	3.5	8	5	12	9	11	8	—
40	13	8.5	13.5	9	10.5	6	12	7.5	16	11.5	15	10.5
50	11	11.5	11.5	12	8.5	9	10	10.5	14	14.5	13	13.5

Auto Switch Mounting Height

	D-A7□ D-A80	D-A7□H D-A80H D-F7□ D-J79 D-F7□W D-F79W D-F7BAL D-F79F D-F7NTL	D-A73C D-A80C	D-F7□V D-F7□WV D-F7BAVL	D-J79C	D-A79W	D-A9□V	D-M9□V D-F9□WV	D-F9BAL	(mm)
	U	U	U	U	U	U	U	U	U	
	19.5	20.5	26.5	23	26	22	—	—	—	
	22.5	23.5	29.5	26	29	25	—	—	—	
	24.5	25.5	31.5	28	31	27	—	—	—	
	27.5	28.5	34.5	31	34	30	—	—	—	
	31.5	32.5	38.5	35	38	34	27	29	26.5	
	35	36	42	38.5	41.5	37.5	30.5	32.5	30	
	41	42	48	44.5	47.5	43.5	36.5	38.5	36	

CUJ

CU

CQS

CQM

CQ2

RQ

MU

D-

-X

20-

Data

Series CQ2

Dimensions: $\phi 12$ to $\phi 25$ /Spring Return without Auto Switch

Basic style (Through-hole): CQ2B

Both ends tapped style: CQ2A

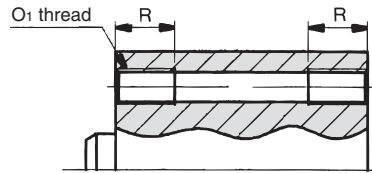

Both Ends Tapped Style

Bore size (mm)	O1	R
12	M4 x 0.7	7
16	M4 x 0.7	7
20	M6 x 1.0	10
25	M6 x 1.0	10

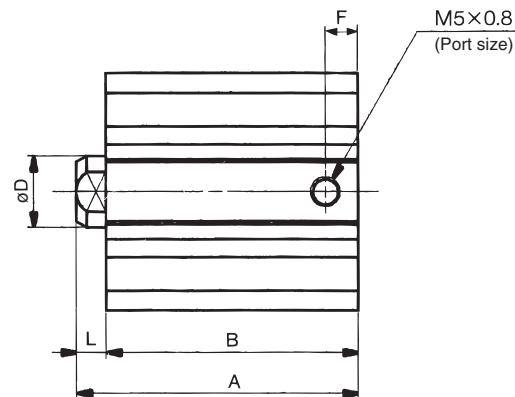
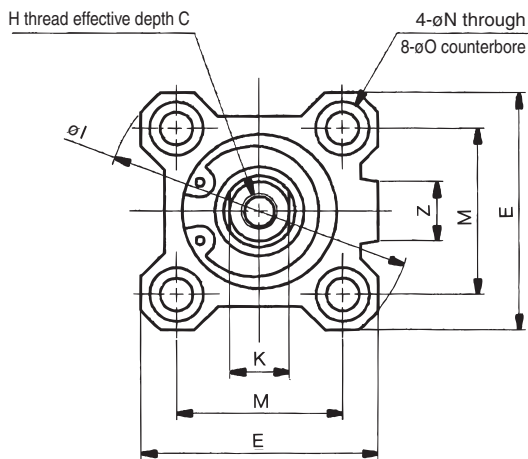

With boss in head side

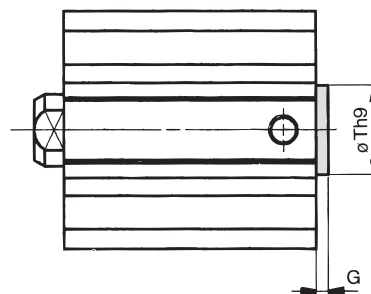

With Boss in Head Side

Bore size (mm)	G	Th9
12	1.5	15 ⁰ _{-0.043}
16	1.5	20 ⁰ _{-0.052}
20	2	13 ⁰ _{-0.043}
25	2	15 ⁰ _{-0.043}

Rod end male thread

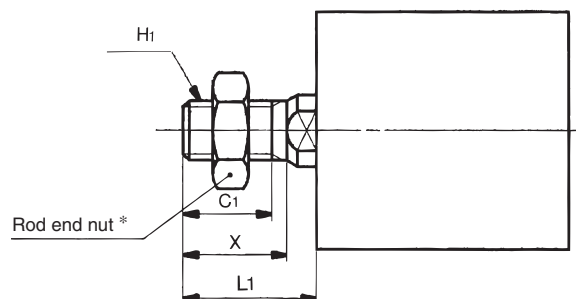

Rod End Male Thread

Bore size (mm)	C1	X	H1	L1
12	9	10.5	M5 x 0.8	14
16	10	12	M6 x 1.0	15.5
20	12	14	M8 x 1.25	18.5
25	15	17.5	M10 x 1.25	22.5

Basic Style

Bore size (mm)	A		B		C	D	E	F	H	I	K	L	M	N	O	Z
	5 st	10 st	5 st	10 st												
12	25.5	30.5	22	27	6	6	25	5	M3 x 0.5	32	5	3.5	15.5	3.5	6.5 depth 3.5	—
16	27	32	23.5	28.5	8	8	29	5.5	M4 x 0.7	38	6	3.5	20	3.5	6.5 depth 3.5	10
20	29	34	24.5	29.5	7	10	36	5.5	M5 x 0.8	47	8	4.5	25.5	5.5	9 depth 7	10
25	32.5	37.5	27.5	32.5	12	12	40	5.5	M6 x 1.0	52	10	5	28	5.5	9 depth 7	10

* For details about the rod end nut and accessory brackets, refer to page 7-6-20.

Compact Cylinder: Standard Type Single Acting, Single Rod, Spring Return/Extend **Series CQ2**

Foot style: CQ2L

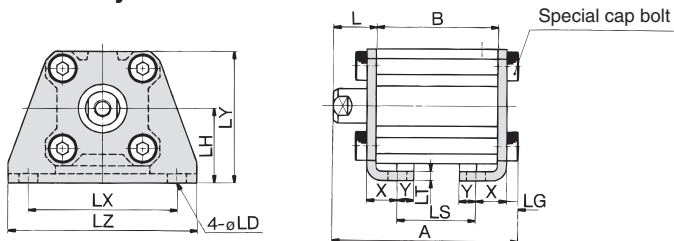

Rod end male thread

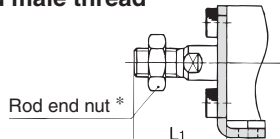

Rod side flange style: CQ2F

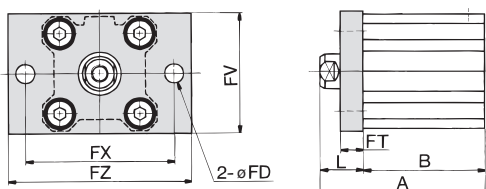

Rod end male thread

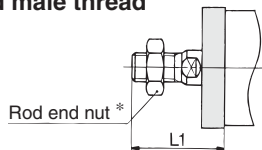

Head side flange style: CQ2G

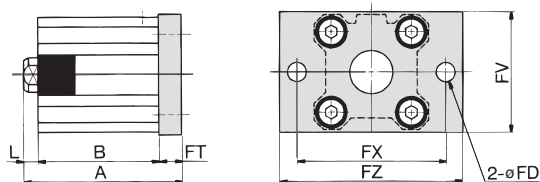

Rod end male thread

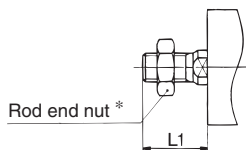

Double clevis style: CQ2D

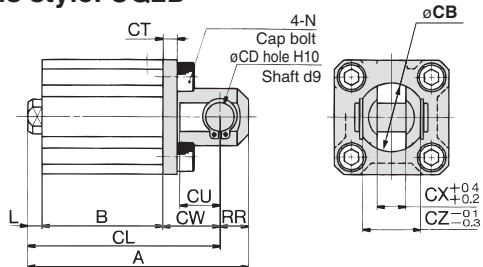

Rod end male thread

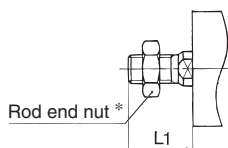

Foot Style

Bore size (mm)	A		B		L	L1	LD	LG	LH	LS		LT	LX	LY	LZ	X	Y
	5 st	10 st	5 st	10 st						5 st	10 st						
12	40.3	45.3	22	27	13.5	24	4.5	2.8	17	10	15	2	34	29.5	44	8	4.5
16	41.8	46.8	23.5	28.5	13.5	25.5	4.5	2.8	19	11.5	16.5	2	38	33.5	48	8	5
20	46.2	51.2	24.5	29.5	14.5	28.5	6.6	4	24	12.5	17.5	3.2	48	42	62	9.2	5.8
25	49.7	54.7	27.5	32.5	15	32.5	6.6	4	26	12.5	17.5	3.2	52	46	66	10.7	5.8

Foot bracket material: Carbon steel

Rod Side Flange Style

Bore size (mm)	A		B		FD	FT	FV	FX	FZ	L	L1
	5 st	10 st	5 st	10 st							
12	35.5	40.5	22	27	4.5	5.5	25	45	55	13.5	24
16	37	42	23.5	28.5	4.5	5.5	30	45	55	13.5	25.5
20	39	44	24.5	29.5	6.6	8	39	48	60	14.5	28.5
25	42.5	47.5	27.5	32.5	6.6	8	42	52	64	15	32.5

Flange bracket material: Carbon steel

Head Side Flange Style

Bore size (mm)	A		L	L1
	5 st	10 st		
12	31	36	3.5	14
16	32.5	37.5	3.5	15.5
20	37	42	4.5	18.5
25	40.5	45.5	5	22.5

Flange bracket material: Carbon steel

(* Dimensions except A, L and L1 are the same as rod side flange style.)

Double Clevis Style

Bore size (mm)	A		B		CB	CD	CL		CT	CU	CW	CX	CZ	L	L1	N	RR
	5 st	10 st	5 st	10 st			5 st	10 st									
12	45.5	50.5	22	27	12	5	39.5	44.5	4	7	14	5	10	3.5	14	M4 x 0.7	6
16	48	53	23.5	28.5	14	5	42	47	4	10	15	6.5	12	3.5	15.5	M4 x 0.7	6
20	56	61	24.5	29.5	20	8	47	52	5	12	18	8	16	4.5	18.5	M6 x 1.0	9
25	62.5	67.5	27.5	32.5	24	10	52.5	57.5	5	14	20	10	20	5	22.5	M6 x 1.0	10

Double clevis bracket material: Carbon steel

* For details about the rod end nut and accessory brackets, refer to page 7-6-20.

** Clevis pin and snap ring are shipped together.

CUJ

CU

CQS

CQM

CQ2

RQ

MU

D-

-X

20-

Data

Compact Cylinder: Standard Type Single Acting, Single Rod, Spring Return/Extend **Series CDQ2**

Foot style: CDQ2L

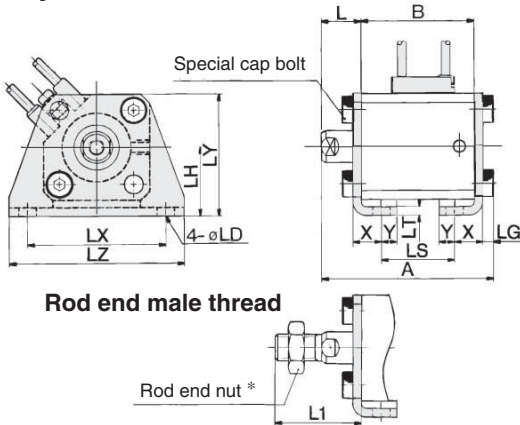

Foot Style

Bore size (mm)	A		B		L	L1	LD	LG	LH	LS		LT	LX	LY	LZ	X	Y
	5 st	10 st	5 st	10 st						5 st	10 st						
12	51.3	56.3	33	38	13.5	24	4.5	2.8	17	21	26	2	34	29.5	44	8	4.5
16	53.8	58.8	35.5	40.5	13.5	25.5	4.5	2.8	19	23.5	28.5	2	38	33.5	48	8	5
20	58.2	63.2	36.5	41.5	14.5	28.5	6.6	4	24	24.5	29.5	3.2	48	42	62	9.2	5.8
25	59.7	64.7	37.5	42.5	15	32.5	6.6	4	26	22.5	27.5	3.2	52	46	66	10.7	5.8

Foot bracket material: Carbon steel

Rod side flange style: CDQ2F

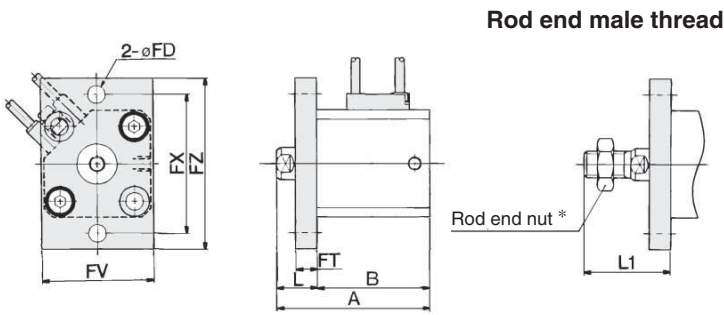

Rod Side Flange Style

Bore size (mm)	A		B		FD	FT	FV	FX	FZ	L	L1
	5 st	10 st	5 st	10 st							
12	46.5	51.5	33	38	4.5	5.5	25	45	55	13.5	24
16	49	54	35.5	40.5	4.5	5.5	30	45	55	13.5	25.5
20	51	56	36.5	41.5	6.6	8	39	48	60	14.5	28.5
25	52.5	57.5	37.5	42.5	6.6	8	42	52	64	15	32.5

Flange bracket material: Carbon steel

Head side flange style: CDQ2G

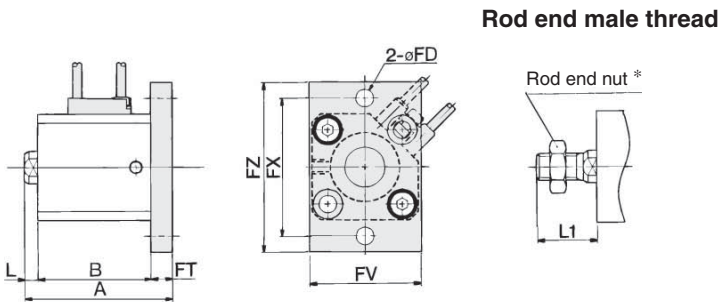

Head Side Flange Style

Bore size (mm)	A		L	L1
	5 st	10 st		
12	46.4	51.4	3.5	14
16	44.5	49.5	3.5	15.5
20	49	54	4.5	18.5
25	50.5	55.5	5	22.5

(* Dimensions except A, L and L1 are the same as rod side flange style.)

Flange bracket material: Carbon steel

Double clevis style: CDQ2A

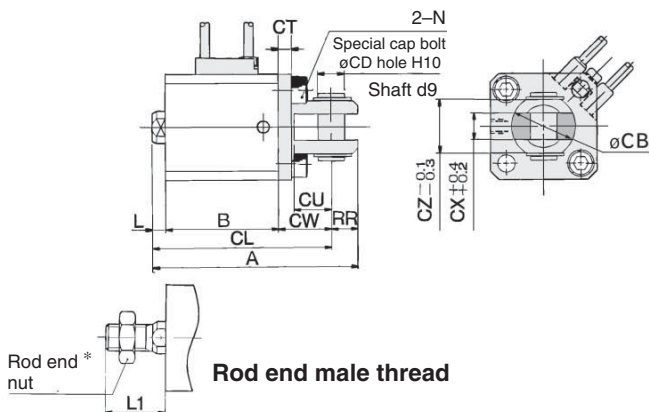

Double Clevis Style

Bore size (mm)	A		B		CB	CD	CL		CT	CU	CW	CX	CZ	L	L1	N	RR
	5 st	10 st	5 st	10 st			5 st	10 st									
12	56.5	61.5	33	38	12	5	50.5	55.5	4	7	14	5	10	3.5	14	M4 x 0.7	6
16	60	65	35.5	40.5	14	5	54	59	4	10	15	6.5	12	3.5	15.5	M4 x 0.7	6
20	68	73	36.5	41.5	20	8	59	64	5	12	18	8	16	4.5	18.5	M6 x 1.0	9
25	72.5	77.5	37.5	42.5	24	10	62.5	67.5	5	14	20	10	20	5	22.5	M6 x 1.0	10

Double clevis bracket material: Carbon steel

* For details about the rod end nut and accessory brackets, refer to page 7-6-20.
** Clevis pin and snap ring are shipped together.

CUJ

CU

CQS

CQM

CQ2

RQ

MU

D-

-X

20-

Data

Series CQ2/CDQ2

(In the case of without auto switches, A, B, F and P dimensions will be only changed. Refer to the dimension chart.)

Dimensions: $\phi 32$ to $\phi 50$ /Spring Return With Auto Switch

Basic style (Through-hole): CQ2B/CDQ2B

Both ends tapped style: CDQ2A

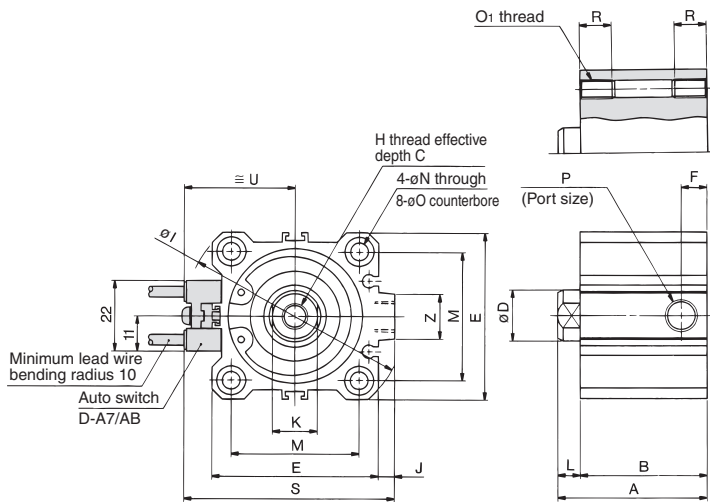

Both Ends Tapped Style

Bore size (mm)	O1	R
32	M6 x 1.0	10
40	M6 x 1.0	10
50	M8 x 1.25	14

With boss in head side

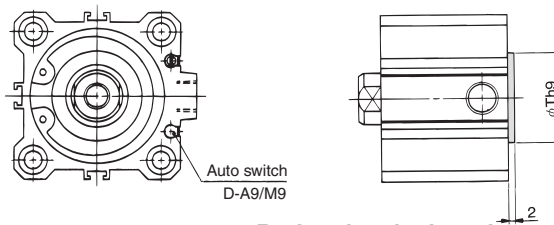

With Boss in Head Side

Bore size (mm)	Th9
32	21 ⁰ _{-0.052}
40	28 ⁰ _{-0.052}
50	35 ⁰ _{-0.062}

Rod end male thread

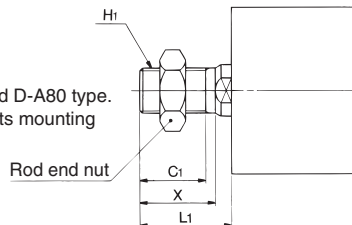

Rod End Male Thread

Bore size (mm)	C1	X	H1	L1
32	20.5	23.5	M14 x 1.5	28.5
40	20.5	23.5	M14 x 1.5	28.5
50	26	28.5	M18 x 1.5	33.5



Auto switch shown above is D-A73 type and D-A80 type.
** For the auto switch mounting position and its mounting height, refer to page 7-6-48.

Built-in One-touch fittings: $\phi 32$ to $\phi 50$

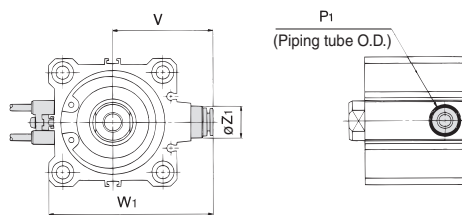

Built-in One-touch Fittings

Bore size (mm)	Z1	P1	V	W1
32	13	6	36.5	59
40	13	6	40.5	66.5
50	16	8	50	82

Basic Style

Bore size (mm)	Without auto switch												With auto switch							
	A			B			F			P			A			B			F	P
	5 st	10 st	20 st	5 st	10 st	20 st	5 st	10 st	20 st	5 st	10 st	20 st	5 st	10 st	20 st	5 st	10 st	20 st		
32	35	40	—	28	33	—	5.5	7.5	—	M5 x 0.8	Rc 1/8	—	45	50	—	38	43	—	7.5	Rc 1/8
40	41.5	46.5	—	34.5	39.5	—	8	8	—	Rc 1/8	—	—	51.5	56.5	—	44.5	49.5	—	8	Rc 1/8
50	—	48.5	58.5	—	40.5	50.5	—	10.5	10.5	—	Rc 1/4	—	—	58.5	68.5	—	50.5	60.5	10.5	Rc 1/4

Bore size (mm)	C	D	E	H	I	J	K	L	M	N	O	S	U	Z
32	13	16	45	M8 x 1.25	60	4.5	14	7	34	5.5	9 depth 7	58.5	31.5	14
40	13	16	52	M8 x 1.25	69	5	14	7	40	5.5	9 depth 7	66	35	14
50	15	20	64	M10 x 1.5	86	7	17	8	50	6.6	11 depth 8	80	41	19



* For details about the rod end nut and accessory brackets, refer to page 7-6-20.

Note) A, B dimensions of $\phi 32$ -5 stroke with One-touch fitting without auto switch are the same dimensions as the stroke $\phi 32$ -10 without auto switch.

Compact Cylinder: Standard Type Single Acting, Single Rod, Spring Return/Extend **Series CQ2/CDQ2**

Foot style: CQ2L/CDQ2L

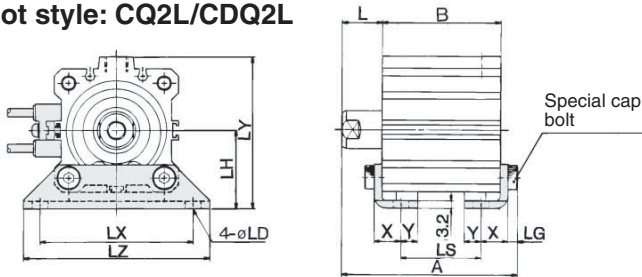

Rod end male thread

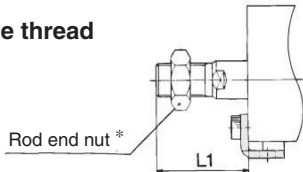

Rod side flange style: CQ2F/CDQ2F

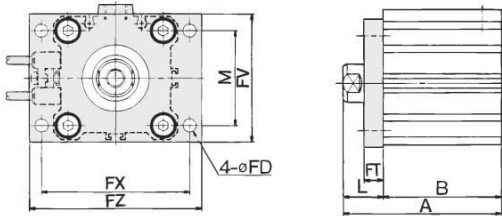

Rod end male thread

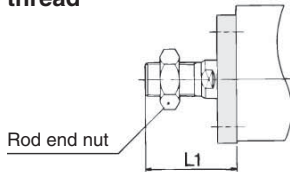

Head side flange style: CQ2G/CDQ2G

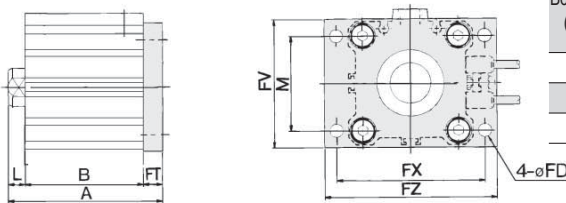

Rod end male thread



Head side flange style: CQ2D/CDQ2D

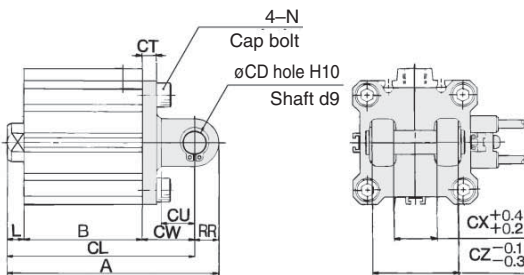

Rod end male thread

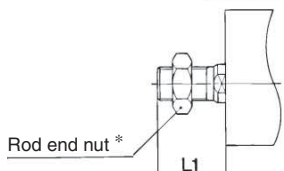

Foot Style

Bore size (mm)	Without auto switch									With auto switch								
	A			B			LS			A			B			LS		
	5 st	10 st	20 st	5 st	10 st	20 st	5 st	10 st	20 st	5 st	10 st	20 st	5 st	10 st	20 st	5 st	10 st	20 st
32	52.5	57.2	—	28	33	—	12	17	—	62.2	67.2	—	38	43	—	22	27	—
40	58.7	63.7	—	34.5	39.5	—	18.5	23.5	—	68.7	73.7	—	44.5	49.5	—	28.5	33.5	—
50	—	66.7	76.7	—	40.5	50.5	—	17.5	27.5	—	76.7	86.7	—	50.5	60.5	—	27.5	37.5

Bore size (mm)	L	L1	LD	LG	LH	LX	LY	LZ	X	Y
32	17	38.5	6.6	4	30	57	57	71	11.2	5.8
40	17	38.5	6.6	4	33	64	64	78	11.2	7
50	18	43.5	9	5	39	79	78	95	14.7	8

Foot bracket material: Carbon steel

Rod Side Flange Style

Bore size (mm)	Without auto switch						With auto switch					
	A			B			A			B		
	5 st	10 st	20 st	5 st	10 st	20 st	5 st	10 st	20 st	5 st	10 st	20 st
32	45	50	—	28	33	—	55	60	—	38	43	—
40	51.5	56.5	—	34.5	39.5	—	61.5	66.5	—	44.5	49.5	—
50	—	58.5	68.5	—	40.5	50.5	—	68.5	78.5	—	50.5	60.5

Bore size (mm)	FD	FT	FV	FX	FZ	L	L1	M
32	5.5	8	48	56	65	17	38.5	34
40	5.5	8	54	62	72	17	38.5	40
50	6.6	9	67	76	89	18	43.5	50

Flange bracket material: Carbon steel

Head Side Flange Style

Bore size (mm)	Without auto switch			With auto switch			L	L1
	A			B				
	5 st	10 st	20 st	5 st	10 st	20 st		
32	43	48	—	53	58	—	7	28.5
40	49.5	54.5	—	59.5	64.5	—	7	28.5
50	—	57.5	67.5	—	67.5	77.5	8	33.5

Flange bracket material: Carbon steel

Double Clevis Style

Bore size (mm)	Without auto switch									With auto switch								
	A			B			CL			A			B			CL		
	5 st	10 st	20 st	5 st	10 st	20 st	5 st	10 st	20 st	5 st	10 st	20 st	5 st	10 st	20 st	5 st	10 st	20 st
32	65	70	—	28	33	—	55	60	—	75	80	—	38	43	—	65	70	—
40	73.5	78.5	—	39.5	39.5	—	63.5	68.5	—	83.5	88.5	—	44.5	49.5	—	73.5	78.5	—
50	—	90.5	100.5	—	40.5	50.5	—	76.5	86.5	—	100.5	110.5	50.5	50.5	60.5	—	86.5	96.5

Bore size (mm)	CD	CT	CU	CW	CX	CZ	L	L1	N	RR
32	10	5	14	20	18	36	7	28.5	M6 x 1.0	10
40	10	6	14	22	18	36	7	28.5	M6 x 1.0	10
50	14	7	20	28	22	44	8	33.5	M8 x 1.25	14

Double clevis bracket material: Cast iron

* For details about the rod end nut and accessory brackets, refer to page 7-6-20.

** Clevis pin and snap ring are attached.

Series CQ2

Dimensions: $\phi 12$ to $\phi 25$ /Spring Extend without Auto Switch

Basic style (Through-hole): CQ2B

Both end tapped style: CQ2A

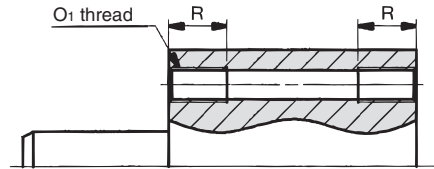

Both Ends Tapped Style

Bore size (mm)	O1	R
12	M4 x 0.7	7
16	M4 x 0.7	7
20	M6 x 1.0	10
25	M6 x 1.0	10

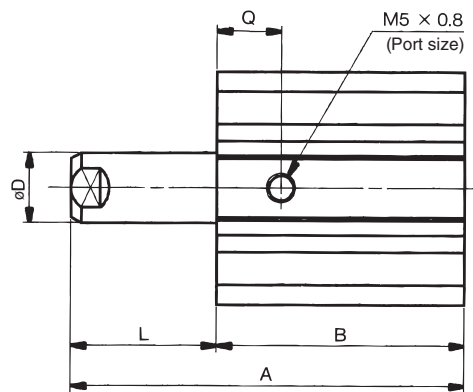
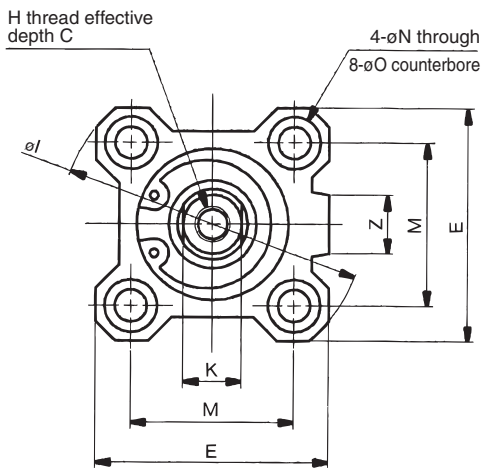

With boss in head side

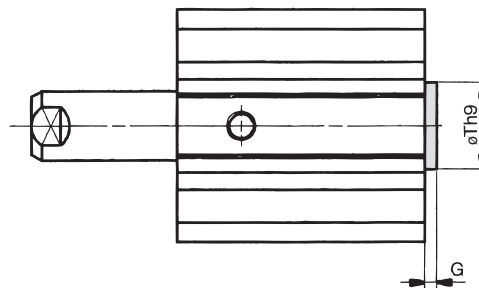

With Boss in Head Side

Bore size (mm)	G	Th9
12	1.5	15 ⁰ _{-0.043}
16	1.5	20 ⁰ _{-0.052}
20	2	13 ⁰ _{-0.043}
25	2	15 ⁰ _{-0.043}

Note) With boss in rod side would be optional. (Suffix "-XC36" to the end of model number.)

Rod end male thread

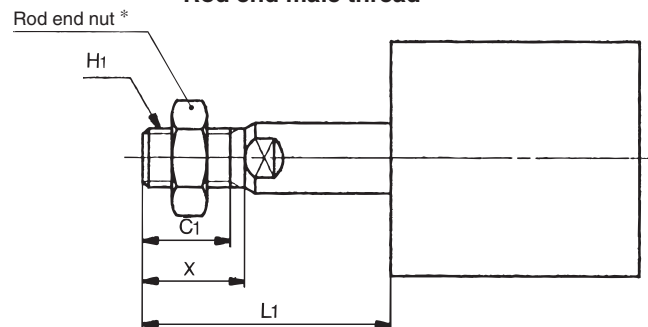

Rod End Male Thread

Bore size (mm)	C1	X	H1	L1	
				5 st	10 st
12	9	10.5	M5 x 0.8	19	24
16	10	12	M6 x 1.0	20.5	25.5
20	12	14	M8 x 1.25	23.5	28.5
25	15	17.5	M10 x 1.25	27.5	32.5

Basic Style

Bore size (mm)	A		B		C	D	E	H	I	K	L		M	N	O	Q	Z
	5 st	10 st	5 st	10 st							5 st	10 st					
12	30.5	40.5	22	27	6	6	25	M3 x 0.5	32	5	8.5	13.5	15.5	3.5	6.5 depth 3.5	7.5	—
16	32	42	23.5	28.5	8	8	29	M4 x 0.7	38	6	8.5	13.5	20	3.5	6.5 depth 3.5	8	10
20	34	44	24.5	29.5	7	10	36	M5 x 0.8	47	8	9.5	14.5	25.5	5.5	9 depth 7	9	10
25	37.5	47.5	27.5	32.5	12	12	40	M6 x 1.0	52	10	10	15	28	5.5	9 depth 7	11	10

* For details about the rod end nut and accessory brackets, refer to page 7-6-20.

Compact Cylinder: Standard Type Single Acting, Single Rod, Spring Return/Extend Series CQ2

Foot style: CQ2L

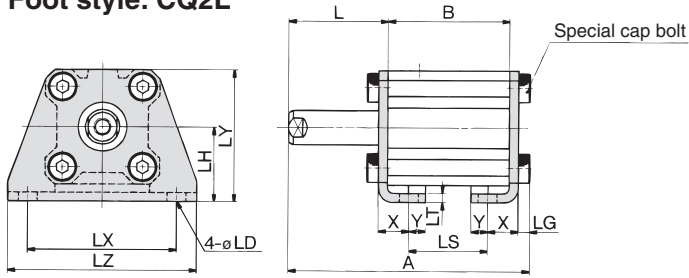

Rod end male thread

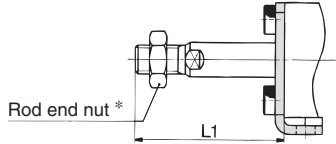

Rod side flange style: CQ2F

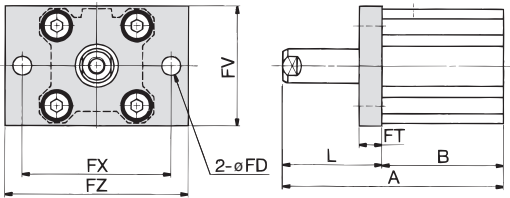

Rod end male thread

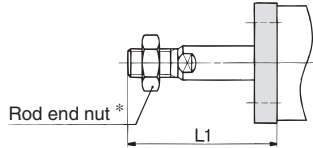

Head side flange style: CQ2G

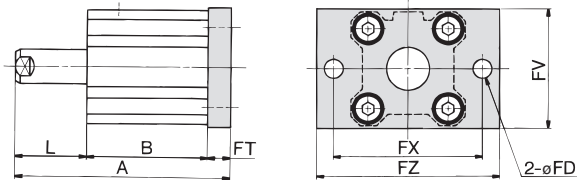

Rod end male thread

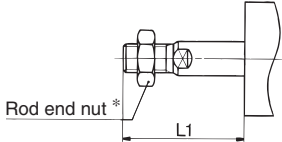

Double clevis style: CQ2D

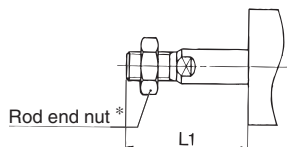
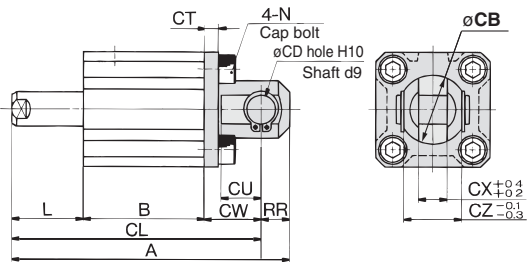

Rod end male thread

Foot Style

Bore size (mm)	A		B		L		L1		LD	LG	LH	LS		LT	LX	LY	LZ	X	Y
	5 st	10 st	5 st	10 st	5 st	10 st	5 st	10 st				5 st	10 st						
12	45.3	55.3	22	27	18.5	23.5	29	34	4.5	2.8	17	10	15	2	34	29.5	44	8	4.5
16	46.8	56.8	23.5	28.5	18.5	23.5	30.5	35.5	4.5	2.8	19	11.5	16.5	2	38	33.5	48	8	5
20	51.2	61.2	24.5	29.5	19.5	24.5	33.5	38.5	6.6	4	24	12.5	17.5	3.2	48	42	62	9.2	5.8
25	54.7	64.7	27.5	32.5	20	25	37.5	42.5	6.6	4	26	12.5	17.5	3.2	52	46	66	10.7	5.8

Foot bracket material: Carbon steel

Rod Side Flange Style

Bore size (mm)	A		B		FD	FT	FV	FX	FZ	L		L1	
	5 st	10 st	5 st	10 st						5 st	10 st	5 st	10 st
12	40.5	50.5	22	27	4.5	5.5	25	45	55	18.5	23.5	29	34
16	42	52	23.5	28.5	4.5	5.5	30	45	55	18.5	23.5	30.5	35.5
20	44	54	24.5	29.5	6.6	8	39	48	60	19.5	24.5	33.5	38.5
25	47.5	57.5	27.5	32.5	6.6	8	42	52	64	20	25	37.5	42.5

Flange bracket material: Carbon steel

Head Side Flange Style

Bore size (mm)	A		L		L1	
	5 st	10 st	5 st	10 st	5 st	10 st
12	36	46	8.5	13.5	19	24
16	37.5	47.5	8.5	13.5	20.5	25.5
20	42	52	9.5	14.5	23.5	28.5
25	45.5	55.5	10	15	27.5	32.5

Flange bracket material: Carbon steel

(* Dimensions except A, L and L1 are the same as rod side flange style.)

Double Clevis Style

Bore size (mm)	A		B		CB	CD	CL		CT	CU	CW	CX	CZ	L		L1		N	RR
	5 st	10 st	5 st	10 st			5 st	10 st						5 st	10 st				
12	50.5	60.5	22	27	12	5	44.5	54.5	4	7	14	5	10	8.5	13.5	19	24	M4 x 0.7	6
16	53	63	23.5	28.5	14	5	47	57	4	10	15	6.5	12	8.5	13.5	20.5	25.5	M4 x 0.7	6
20	61	71	24.5	29.5	20	8	52	62	5	12	18	8	16	9.5	14.5	23.5	28.5	M6 x 1.0	9
25	67.5	77.5	27.5	32.5	24	10	57.5	67.5	5	14	20	10	20	10	15	27.5	32.5	M6 x 1.0	10

Double clevis bracket material: Carbon steel



* For details about the rod end nut and accessory brackets, refer to page 7-6-20.
** Clevis pin and snap ring are attached.

CUJ

CU

CQS

CQM

CQ2

RQ

MU

D-

-X

20-

Data

Series CDQ2

Dimensions: $\phi 12$ to $\phi 25$ /Spring Extend with Auto Switch

Basic style (Through-hole): CDQ2B

With boss in head side: CDQ2A

Both Ends Tapped Style

Bore size (mm)	O1	R
12	M4 x 0.7	7
16	M4 x 0.7	7
20	M6 x 1.0	10
25	M6 x 1.0	10

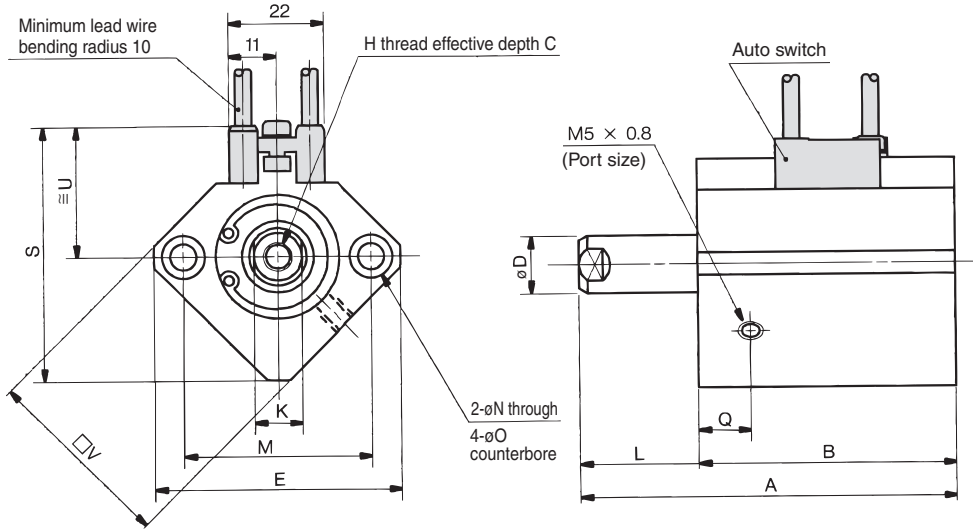

With boss in head side

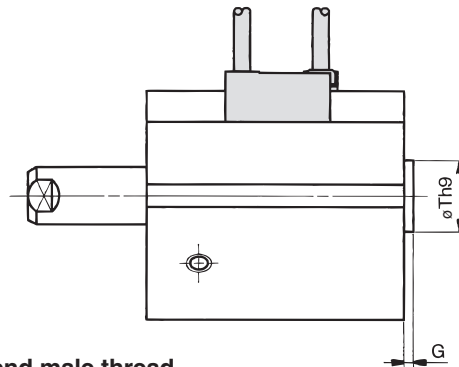

With Boss in Head Side

Bore size (mm)	G	Th9
12	1.5	15 ⁰ _{-0.043}
16	1.5	20 ⁰ _{-0.052}
20	2	13 ⁰ _{-0.043}
25	2	15 ⁰ _{-0.043}

Note) With boss in rod side would be optional.
(Suffix "-XC36" to the end of model number.)

Rod end male thread

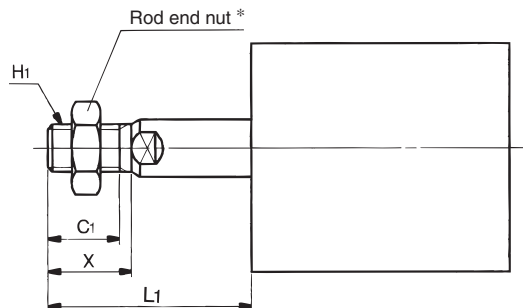

Rod End Male Thread

Bore size (mm)	C1	X	H1	L1	
				5 st	10 st
12	9	10.5	M5 x 0.8	19	24
16	10	12	M6 x 1.0	20.5	25.5
20	12	14	M8 x 1.25	23.5	28.5
25	15	17.5	M10 x 1.25	27.5	32.5



Auto switch shown above is D-A73 type and D-A80 type. For the auto switch mounting position and its mounting height, refer to page 7-6-48.

Basic Style

Bore size (mm)	A		B		C	D	E	H	K	L		M	N	O	Q	S	U	V
	5 st	10 st	5 st	10 st						5 st	10 st							
12	45.9	55.9	37.4	42.4	6	6	32	M3 x 0.5	5	8.5	13.5	22	3.5	6.5 depth 3.5	11	35.5	19.5	25
16	44	54	35.5	40.5	8	8	38	M4 x 0.7	6	8.5	13.5	28	3.5	6.5 depth 3.5	10	41.5	22.5	29
20	46	56	36.5	41.5	7	10	47	M5 x 0.8	8	9.5	14.5	36	5.5	9 depth 7	10.5	48	24.5	36
25	47.5	57.5	37.5	42.5	12	12	52	M6 x 1.0	10	10	15	40	5.5	9 depth 7	11	53.5	27.5	40



* For details about the rod end nut and accessory brackets, refer to page 7-6-20.

Compact Cylinder: Standard Type Single Acting, Single Rod, Spring Return/Extend Series **CDQ2**

Foot style: CDQ2L

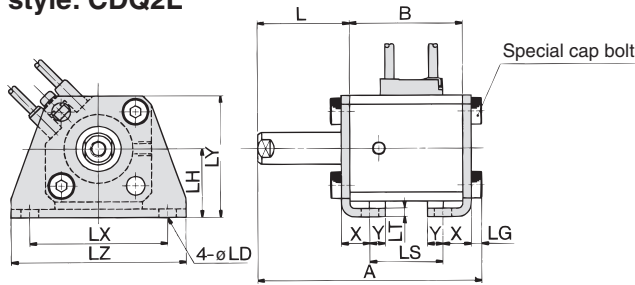

Rod end male thread

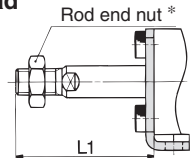

Rod side flange style: CDQ2F

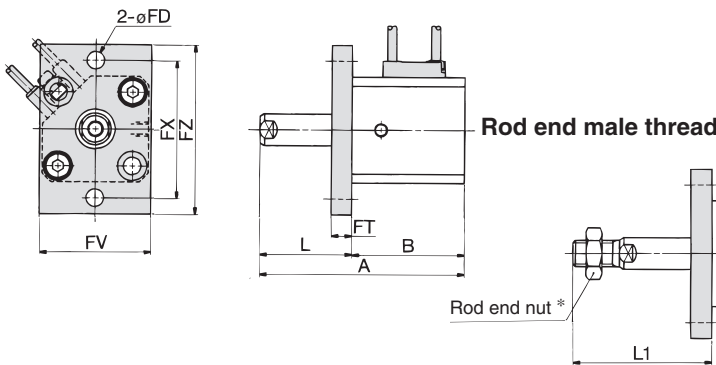

Head side flange style: CDQ2G

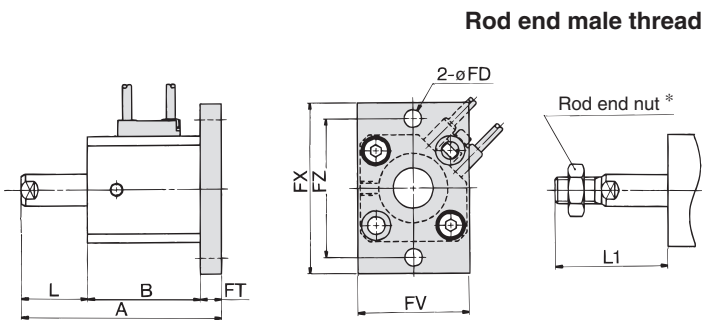

Double clevis style: CDQ2D

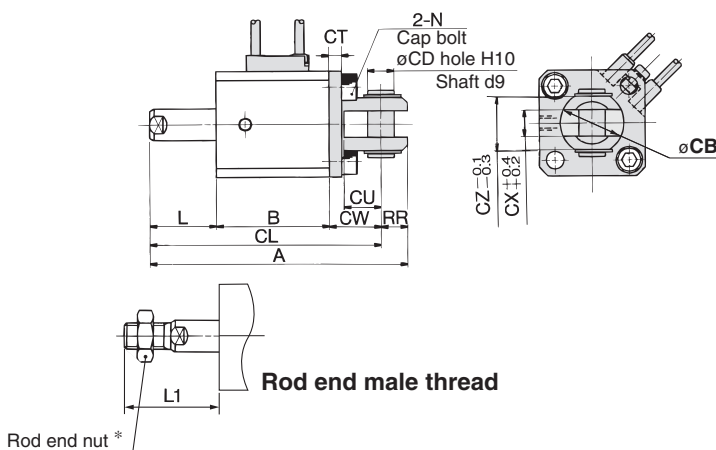

Foot Style

Bore size (mm)	A		B		L		L1		LD	LG	LH	LS		LT	LX	LY	LZ	X	Y
	5 st	10 st	5 st	10 st	5 st	10 st	5 st	10 st				5 st	10 st						
12	60.7	70.7	37.4	42.4	18.5	23.5	29	34	4.5	2.8	17	25.4	30.4	2	34	29.5	44	8	4.5
16	58.8	68.8	35.5	40.5	18.5	23.5	30.5	35.5	4.5	2.8	19	23.5	28.5	2	38	33.5	48	8	5
20	63.2	73.2	36.5	41.5	19.5	24.5	33.5	38.5	6.6	4	24	24.5	29.5	3.2	48	42	62	9.2	5.8
25	64.7	74.7	37.5	42.5	20	25	37.5	42.5	6.6	4	26	22.5	27.5	3.2	52	46	66	10.7	5.8

Foot bracket material: Carbon steel

Rod Side Flange Style

Bore size (mm)	A		B		FD	FT	FV	FX	FZ	L		L1	
	5 st	10 st	5 st	10 st						5 st	10 st	5 st	10 st
12	55.9	65.9	37.4	42.4	4.5	5.5	25	45	55	18.5	23.5	29	34
16	54	64	35.5	40.5	4.5	5.5	30	45	55	18.5	23.5	30.5	35.5
20	56	66	36.5	41.5	6.6	8	39	48	60	19.5	24.5	33.5	38.5
25	57.5	67.5	37.5	42.5	6.6	8	42	52	64	20	25	37.5	42.5

Flange bracket material: Carbon steel

Head Side Flange Style

Bore size (mm)	A		L		L1	
	5 st	10 st	5 st	10 st	5 st	10 st
12	51.4	61.4	8.5	13.5	19	24
16	49.5	59.5	8.5	13.5	20.5	25.5
20	54	64	9.5	14.5	23.5	28.5
25	55.5	65.5	10	15	27.5	32.5

Flange bracket material: Carbon steel

(* Dimensions except A, L and L1 are the same as rod side flange style.)

Double Clevis Style

Bore size (mm)	A		B		CB	CD	CL		CT	CU	CW	CX	CZ	L	
	5 st	10 st	5 st	10 st			5 st	10 st						5 st	10 st
12	65.9	75.9	37.4	42.4	12	5	59.9	69.9	4	7	14	5	10	8.5	13.5
16	65	75	35.5	40.5	14	5	59	69	4	10	15	6.5	12	8.5	13.5
20	73	83	36.5	41.5	20	8	64	74	5	12	18	8	16	9.5	14.5
25	77.5	87.5	37.5	42.5	24	10	67.5	77.5	5	14	20	10	20	10	15

Double clevis bracket material: Carbon steel

* For details about the rod end nut and accessory brackets, refer to page 7-6-20.

** Clevis pin and snap ring are shipped together.

CUJ

CU

CQS

CQM

CQ2

RQ

MU

D-

-X

20-

Data



(In the case of without auto switches, A, B, P and Q dimensions will be only changed. Refer to the dimension table.)

Series CQ2/CDQ2

Dimensions: ø32 to ø50/Spring Extend with Auto Switch

Basic style (Through-hole):
CQ2B, CDQ2B

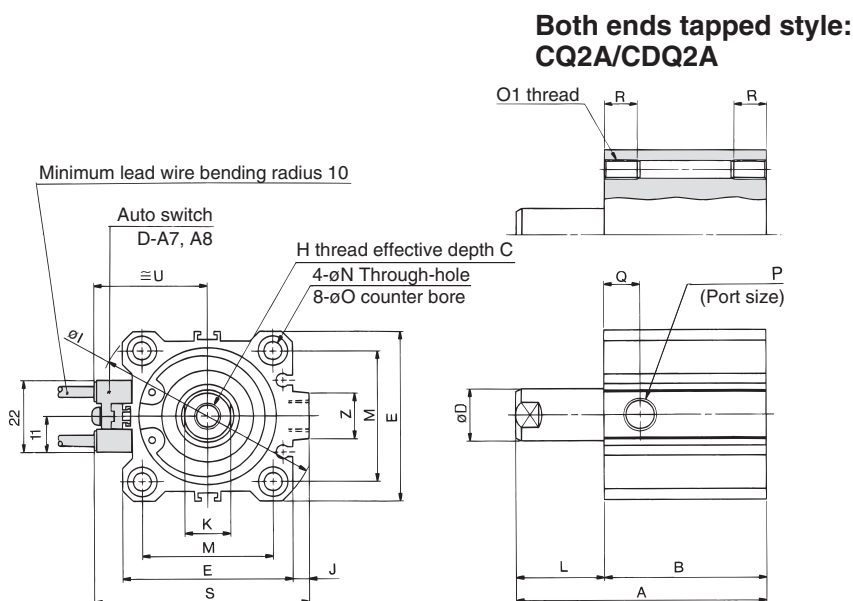

Both Ends Tapped Style

Bore size (mm)	O1	R
32	M6 x 1.0	10
40	M6 x 1.0	10
50	M8 x 1.25	14

With boss in head side

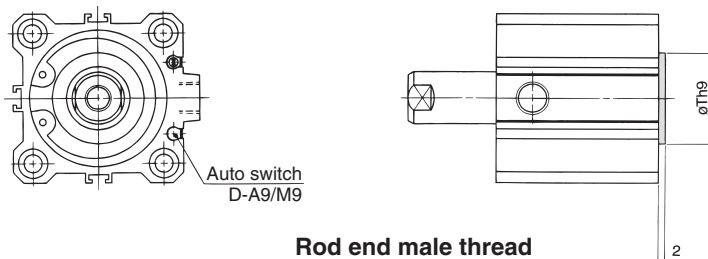

With Boss in Head Side

Bore size (mm)	Th9
32	21 ⁰ _{-0.052}
40	28 ⁰ _{-0.052}
50	35 ⁰ _{-0.062}

Note) With boss in rod side would be optional. (Suffix "-XC36" to the end of model number.)

Rod end male thread

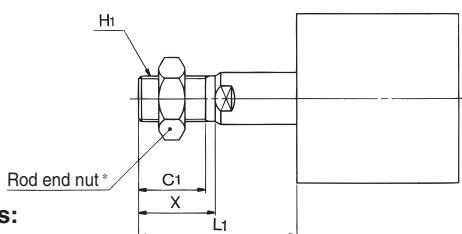

Rod End Male Thread

Bore size (mm)	C1	X	H1	L1		
				5 st	10 st	20 st
32	20.5	23.5	M14 x 1.5	33.5	38.5	—
40	20.5	23.5	M14 x 1.5	33.5	38.5	—
50	26	28.5	M18 x 1.5	—	43.5	53.5

Built-in One-touch fittings: ø32 to ø50



Auto switch shown above is D-A73 and D-A80. For the auto switch mounting position and its mounting height, refer to page 7-6-48.

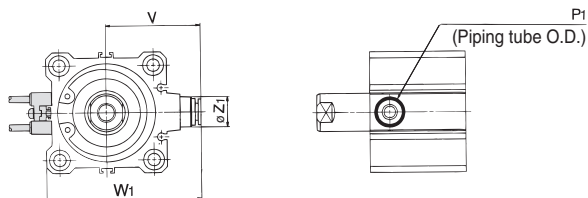

Built-in One-touch Fittings

Bore size (mm)	Z1	P1	V	W1
32	13	6	36.5	59
40	13	6	40.5	66.5
50	16	8	50	82

Basic Style

Bore size (mm)	Without auto switch								With auto switch											
	A		B		P		Q		A		B		P	Q						
	5 st	10 st	20 st	5 st	10 st	20 st	5 st	10 st	20 st	5 st	10 st	20 st	5 st	10 st	20 st					
32	40	50	—	28	33	—	M5 x 0.8	Rc 1/8	—	11.5	10.5	—	50	60	—	38	43	—	Rc 1/8	10.5
40	46.5	56.5	—	34.5	39.5	—	Rc 1/8	—	11	11	—	56.5	66.5	—	44.5	49.5	—	Rc 1/8	11	
50	—	68.5	78.5	—	40.5	50.5	—	Rc 1/4	—	10.5	10.5	—	68.5	88.5	—	50.5	60.5	—	Rc 1/4	10.5

Bore size (mm)	C	D	E	H	I	J	K	L			M	N	O	S	U	Z
								5 st	10 st	20 st						
32	13	16	45	M8 x 1.25	60	4.5	14	12	17	—	34	5.5	9 depth 7	58.5	31.5	14
40	13	16	52	M8 x 1.25	69	5	14	12	17	—	40	5.5	9 depth 7	66	35	14
50	15	20	64	M10 x 1.5	86	7	17	—	18	28	50	6.6	11 depth 8	80	41	19



* For details about the rod end nut and accessory brackets, refer to page 7-6-20.

Compact Cylinder: Standard Type Single Acting, Single Rod, Spring Return/Extend Series **CQ2/CDQ2**

Foot style: CQ2L/CDQ2L

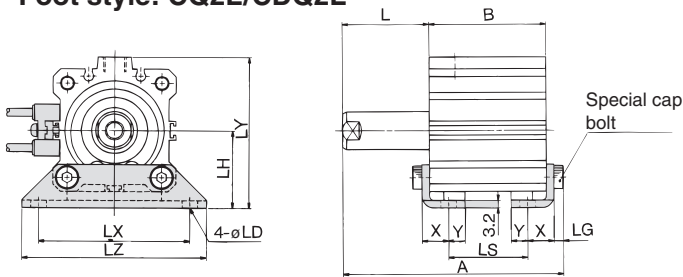

Rod end male thread

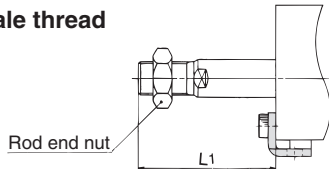

Rod side flange style: CQ2F/CDQ2F

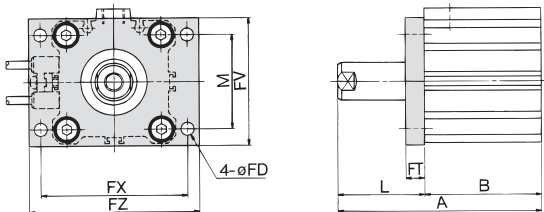

Rod end male thread

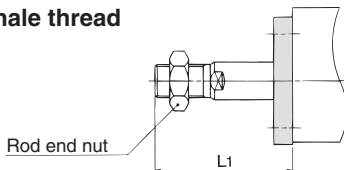

Head side flange style: CQ2G/CDQ2G

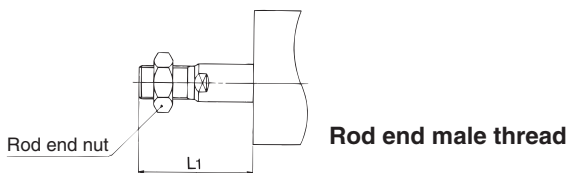
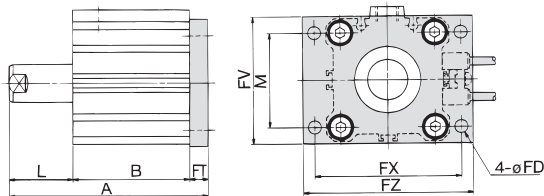

Double clevis style: CQ2D/CDQ2D

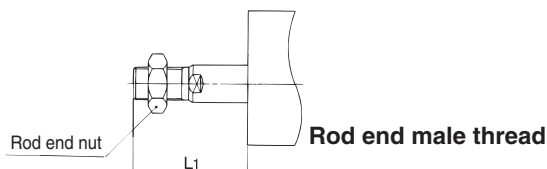
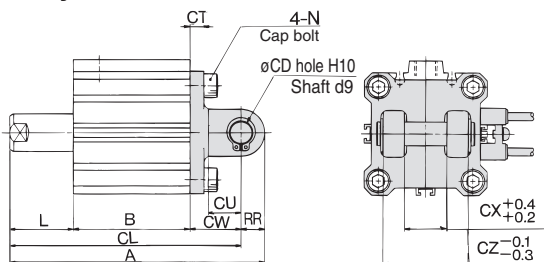

Foot Style

Bore size (mm)	Without auto switch									With auto switch								
	A			B			LS			A			B			LS		
	5 st	10 st	20 st	5 st	10 st	20 st	5 st	10 st	20 st	5 st	10 st	20 st	5 st	10 st	20 st	5 st	10 st	20 st
32	57.2	67.2	—	28	33	—	12	17	—	67.2	77.2	—	38	43	—	22	27	—
40	63.7	73.7	—	34.5	39.5	—	18.5	23.5	—	73.7	83.7	—	44.5	49.5	—	28.5	33.5	—
50	—	76.7	96.7	—	40.5	50.5	—	17.5	27.5	—	86.7	106.7	—	50.5	60.5	—	27.5	37.5

Bore size (mm)	L			L1			LD	LG	LH	LX	LY	LZ	X	Y
	5 st	10 st	20 st	5 st	10 st	20 st								
	32	22	27	—	43.5	48.5								
40	22	27	—	43.5	48.5	—	6.6	4	33	64	64	78	11.2	7
50	—	28	38	—	53.5	63.5	9	5	39	79	78	95	14.7	8

Foot bracket material: Carbon steel

Rod Side Flange Style

Bore size (mm)	Without auto switch						With auto switch						FD	FT	FV	FX	FZ
	A			B			A			B							
	5 st	10 st	20 st	5 st	10 st	20 st	5 st	10 st	20 st	5 st	10 st	20 st					
32	50	60	—	28	33	—	60	70	—	38	43	—	5.5	8	45	56	65
40	56.5	66.5	—	34.5	39.5	—	66.5	76.5	—	44.5	49.5	—	5.5	8	54	62	72
50	—	68.5	88.5	—	40.5	50.5	—	78.5	98.5	—	50.5	60.5	6.6	9	67	76	89

Bore size (mm)	L			L1			M
	5 st	10 st	20 st	5 st	10 st	20 st	
	32	22	27	—	43.5	48.5	
40	22	27	—	43.5	48.5	—	40
50	—	28	38	—	53.5	63.5	50

Flange bracket material: Carbon steel

Head Side Flange Style

Bore size (mm)	Without auto switch			With auto switch			L			L1					
	A			B			5 st			10 st			20 st		
	5 st	10 st	20 st	5 st	10 st	20 st	5 st	10 st	20 st	5 st	10 st	20 st			
32	48	58	—	58	68	—	12	17	—	33.5	38.5	—			
40	45.5	64.5	—	64.5	74.5	—	12	17	—	33.5	38.5	—			
50	—	67.5	87.5	—	77.5	97.5	—	18	28	—	43.5	53.5			

Flange bracket material: Carbon steel

(* Dimensions except A, L and L1 are the same as rod side flange style.)

Double Clevis Style

Bore size (mm)	Without auto switch									With auto switch								
	A			B			CL			A			B			CL		
	5 st	10 st	20 st	5 st	10 st	20 st	5 st	10 st	20 st	5 st	10 st	20 st	5 st	10 st	20 st	5 st	10 st	20 st
32	70	80	—	28	33	—	60	70	—	80	90	—	38	43	—	70	80	—
40	78.5	88.5	—	34.5	39.5	—	68.5	78.5	—	88.5	98.5	—	44.5	49.5	—	78.5	88.5	—
50	—	100.5	120.5	—	40.5	50.5	—	86.5	106.5	—	110.5	130.5	—	50.5	60.5	—	96.5	116.5

Bore size (mm)	CD	CT	CU	CW	CX	CZ	L			L1		
							5 st	10 st	20 st	5 st	10 st	20 st
							32	10	5	14	20	18
40	10	6	14	22	18	36	12	17	—	33.5	38.5	—
50	14	7	20	28	22	44	—	18	28	—	43.5	53.5

Double clevis bracket material: Cast iron



* For details about the rod end nut and accessory brackets, refer to page 7-6-20.

** Clevis pin and snap ring are shipped together.



Compact Cylinder: Non-rotating Rod Type

Double Acting, Single Rod

Series CQ2K

ø12, ø16, ø20, ø25, ø32, ø40, ø50, ø63

How to Order

Without auto switch

With auto switch

Built-in magnet

Non-rotating rod type

Mounting style

B	Through-hole (Standard)	ø12 to ø63
A	Both ends tapped style	
L	Foot style	
F	Rod side flange style	ø40, ø50, ø63
G	Head side flange style	
D	Double clevis style	

* Mounting brackets are shipped together, (but not assembled).

Bore size

12	12 mm	32	32 mm
16	16 mm	40	40 mm
20	20 mm	50	50 mm
25	25 mm	63	63 mm

Note) When ø12 with switch is required, the body option should be with rubber bumper (C).
Ex.) CDQ2KB12-30DC

Auto switch

Nil	Without auto switch (Built-in magnet)
-----	---------------------------------------

* For the applicable auto switch model, refer to the table below.
* Auto switches are shipped together, (but not assembled). (Except D-P5DWL)

Body option

Nil	Standard (Rod end female thread)
F	With boss in head side
C	With rubber bumper (Only ø12 with switch)
M	Rod end male thread

* Combination of body option (FM) is available.

Action

D	Double acting
---	---------------

Cylinder stroke (mm)

Refer to "Standard Stroke" on page 7-6-63.

Piping

Nil	Screw-in piping
F	Built-in One-touch fittings

Note) Bore sizes available w/ One-touch fittings are ø32 to ø63.

Number of auto switches

Nil	2 pcs.
S	1 pc.
n	"n" pcs.

Applicable Auto Switch

Refer to page 7-9-1 for further information on auto switches.

Type	Special function	Electrical entry	Indicator light	Wiring (Output)	Load voltage		Rail mounting		Direct mounting		Lead wire length (m) *				Pre-wire connector	Applicable load			
					DC	AC	ø12 to ø63		ø32 to ø63		0.5 (Nil)	3 (L)	5 (Z)	None (N)		IC circuit	Relay, PLC		
							Perpendicular	In-line	Perpendicular	In-line									
Reed switch	—	Grommet	Yes	3-wire (NPN equivalent)	—	5 V	—	A76H	A96V	A96	●	●	—	—	—	IC circuit	—		
				2-wire	—	—	200 V	A72	A72H	—	—	—	●	●	—	—	—	—	Relay, PLC
	Diagnostic indication (2-color indication)	Connector		2-wire	24 V	12 V	100 V	—	—	A93V	A93	●	●	—	—	—	—		
				Grommet	—	—	—	A73C	—	—	—	—	●	●	●	●	—	—	—
Solid state switch	—	Grommet	Yes	3-wire (NPN)	5 V, 12 V	—	—	F7NV	F79	M9NV	M9N	●	●	○	—	○	IC circuit		
				3-wire (PNP)				F7PV	F7P	M9PV	M9P	●	●	○	—	○			
	Diagnostic indication (2-color indication)	Connector		2-wire	24 V	12 V	—	—	F7BV	J79	M9BV	M9B	●	●	○	—	○	—	
				3-wire (NPN)					F7NWV	F79W	F9NWV	F9NW	●	●	○	—	○		
	Water resistant (2-color indication)	Grommet		3-wire (PNP)	5 V, 12 V	—	—	—	—	F7PW	F9PWV	F9PW	●	●	○	—	○	IC circuit	
				2-wire	24 V	12 V	—	—	—	—	F7BWV	J79W	F9BWV	F9BW	●	●	○		—
	With diagnostic output (2-color indication)	Grommet		4-wire (NPN)	5 V, 12 V	—	—	—	—	—	F7BA	—	F9BA	—	●	○	—	○	—
				2-wire	—	—	—	—	—	—	—	—	—	—	●	●	—	○	
	Magnetic field resistant (2-color indication)	Grommet		2-wire	—	—	—	—	—	—	F7BAV	—	—	—	●	○	—	○	IC circuit
				—	—	—	—	—	—	—	—	—	—	—	●	●	—	○	
—	—	—	—	—	—	—	—	—	P5DW	—	—	●	●	—	○	—			

* Lead wire length symbols: 0.5 m.....Nil (Example) A73C
 3 m.....L (Example) A73CL
 5 m.....Z (Example) A73CZ
 None.....N (Example) A73CN

* Solid state switches marked with "○" are produced upon receipt of order.
 • D-P5DWL type is available from ø40 to ø63 only.
 • There are other applicable auto switches other than the listed above. For details, refer to page 7-6-23.
 • For details about auto switches with pre-wire connector, refer to page 7-9-36.

Compact Cylinder: Non-rotating Rod Type Double Acting, Single Rod Series CQ2K



JIS Symbol
Non-rotating rod

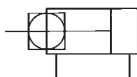

⚠️ Precautions

Be sure to read before handling. For Safety Instructions and Actuator Precautions, refer to pages 7-13-3 to 7-13-6.

⚠️ Caution

Snap Ring Installation/Removal

- For installation and removal, use an appropriate pair of pliers (tool for installing a type C snap ring).
- Even if a proper plier (tool for installing type C snap ring) is used, it is likely to inflict damage to a human body or peripheral equipment, as a snap ring may be flown out of the tip of a plier (tool for installing a type C snap ring). Be much careful with the popping of a snap ring. Besides, be certain that a snap ring is placed firmly into the groove of rod cover before supplying air at the time of installment.

Mounting

- When removing a load, be sure to secure the wrench flats of the piston rod on the load side.
- If this is done without securing the piston rod on the load side, be aware that the coupled (screwed-in) portion of the piston rod could become loosened.



- Using a non-rotating rod cylinder
 - Avoid using the air cylinder in such a way that rotational torque would be applied to the piston rod. If rotational torque is applied, the non-rotating guide will deform, causing a loss of non-rotating accuracy. Use the chart below as a guide for the allowable rotational torque ranges.

Allowable rotational torque	12	16	20	25	32	40	50	63
N·m or less	0.04	0.15	0.20	0.25	0.44	0.44	0.44	0.44

- Operate the cylinder in such a way that the load to the piston rod is always applied in the axial direction.

Type

Bore size (mm)		12	16	20	25	32	40	50	63	
Pneumatic	Mounting	Through-hole (Standard)	●	●	●	●	●	●	●	
		Both ends tapped style	—	—	—	—	—	●	●	●
	Piping	Built-in magnet	●	●	●	●	●	●	●	●
		Screw-in type	M5 x 0.8	M5 x 0.8	M5 x 0.8	M5 x 0.8	M5 x 0.8 <small>Note)</small> Rc 1/8	Rc 1/8	Rc 1/4	Rc 1/4
		Built-in One-touch fittings	—	—	—	—	ø6/4	ø6/4	ø8/6	ø8/6
		Rod end male thread	●	●	●	●	●	●	●	●
With boss in head side	●	●	●	●	●	●	●	●		

Note) In the case of without auto switch, M5 x 0.8 is used for 5 stroke only.

Standard Specifications

Type	Pneumatic (Non-lube)
Fluid	Air
Proof pressure	1.5 MPa
Maximum operating pressure	1.0 MPa
Ambient and fluid temperature	Without auto switch: -10 to 70°C (No freezing) With auto switch: -10 to 60°C (No freezing)
Rubber bumper	None
Rod end thread	Female thread
Rod end thread tolerance	JIS Class 2
Stroke length tolerance	+1.0 0
Mounting	Through-hole
Piston speed	50 to 500 mm/s

Allowable Kinetic Energy

(J)

Bore size (mm)	12	16	20	25	32	40	50	63
Allowable kinetic energy	0.022	0.038	0.055	0.09	0.15	0.26	0.46	0.77

Minimum Operating Pressure (MPa)

Bore (mm)	12	16	20	25	32	40	50	63
Minimum operating pressure	0.07	0.07	0.05	0.05	0.05	0.05	0.05	0.05

Standard Stroke

Bore (mm)	Standard stroke
12, 16	5, 10, 15, 20, 25, 30
20, 25	5, 10, 15, 20, 25, 30, 35, 40, 45, 50
32, 40	5, 10, 15, 20, 25, 30, 35, 40, 45, 50, 75, 100
50, 63	10, 15, 20, 25, 30, 35, 40, 45, 50, 75, 100

Non-rotating Accuracy

Bore (mm)	12	16	20	25	32	40	50	63
Rod non-rotating accuracy	±2°	±1°			±0.8°			

Manufacture of Intermediate Stroke

Description	Spacer is installed in the standard stroke body.	
Part no.	Refer to "How to Order" for the standard model no. on page 7-6-62.	
Description	Dealing with the stroke by the 1 mm interval is available by installing spacer with standard stroke cylinder.	
Stroke range	Bore size	Stroke range
	12, 16	1 to 29
	20, 25	1 to 49
	32 to 63	1 to 99
Example	Part no.: CQ2KB50-57D CQ2KB50-75D with 18 mm width spacer inside. B dimension is 115.5 mm.	

Series CQ2K



Made to Order Specifications (For details, refer to page 7-10-1.)

Symbol	Specifications
-XA□	Change of rod end shape
-XB10	Intermediate stroke (Using exclusive body)
-XC8	Adjustable stroke cylinder/Adjustable extension type
-XC9	Adjustable stroke cylinder/Adjustable retraction type
-XC10	Dual stroke cylinder/Double rod type
-XC11	Dual stroke cylinder/Single rod type
-XC18	NPT finish piping port

Theoretical Output

(N)

Bore size (mm)	Operating direction	Operating pressure (MPa)			Bore size (mm)	Operating direction	Operating pressure (MPa)		
		0.3	0.5	0.7			0.3	0.5	0.7
12	IN	25	42	59	32	IN	181	302	422
	OUT	34	57	79		OUT	241	402	563
16	IN	45	75	106	40	IN	317	528	739
	OUT	60	101	141		OUT	377	628	880
20	IN	71	118	165	50	IN	495	825	1150
	OUT	94	157	220		OUT	589	982	1370
25	IN	113	189	264	63	IN	841	1400	1960
	OUT	147	245	344		OUT	935	1560	2180

Mounting Bracket Part No.

Bore size (mm)	Foot ⁽³⁾	Flange	Double clevis
40	CQ-L040	CQ-F040	CQ-D040
50	CQ-L050	CQ-F050	CQ-D050
63	CQ-L063	CQ-F063	CQ-D063



Note 3) Order two foot brackets per cylinder.

Note 4) Parts belonging to each bracket are as follows.

Foot or Flange style/Body mounting bolt, Double clevis style: Clevis pin, Type C snap ring for axis/Body mounting bolt.

Compact Cylinder: Non-rotating Rod Type Double Acting, Single Rod Series CQ2K

Weight

(g)

Bore size (mm)	Cylinder stroke (mm)											
	5	10	15	20	25	30	35	40	45	50	75	100
12	60	67	74	81	88	95	—	—	—	—	—	—
16	58	67	76	85	94	103	—	—	—	—	—	—
20	103	117	131	145	159	173	187	201	215	229	—	—
25	137	152	167	182	197	212	227	242	257	272	—	—
32	203	223	243	263	283	303	323	343	363	383	403	423
40	215	238	261	284	307	330	353	376	399	422	445	468
50	—	381	418	455	492	529	566	603	640	677	714	751
63	—	550	592	634	676	718	760	802	844	886	928	970

Additional Weight

(g)

Bore size (mm)	12	16	20	25	32	40	50	63
Both ends tapped style	—	—	—	—	—	6	6	19
Rod end male thread	Male thread	1.5	3	6	12	26	27	53
	Nut	1	2	4	8	17	17	32
With boss in head side	0.7	1.3	2	3	5	7	13	25
Built-in One-touch fittings	—	—	—	—	12	12	21	21
Foot style (Including mounting bolt)	—	—	—	—	—	154	242	323
Rod side flange style (Including mounting bolt)	—	—	—	—	—	213	372	558
Rear flange style (Including mounting bolt)	—	—	—	—	—	198	348	534
Double clevis style (Including pin, snap ring, bolt)	—	—	—	—	—	196	393	554

Calculation: (Example) CQ2KD40-20DM • Cylinder weight: CQ2KA40-20D 284 g
 • Option weight: Both ends tapped style 6 g
 Rod end male thread 44 g
 Double clevis style 196 g
 530 g

Construction

Basic style (Bore size ϕ 12 to ϕ 32)

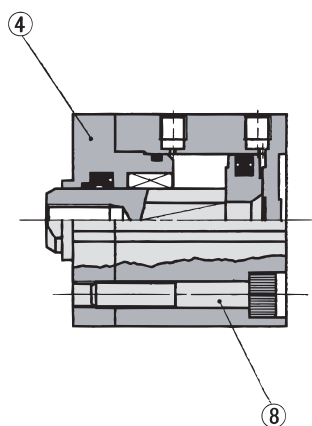

Basic style (Bore size ϕ 40 to ϕ 63)

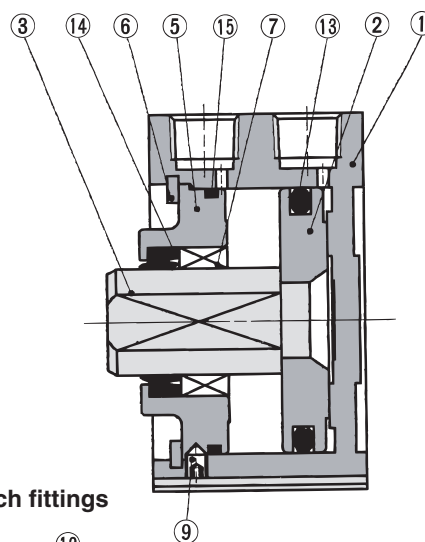

With boss in head side

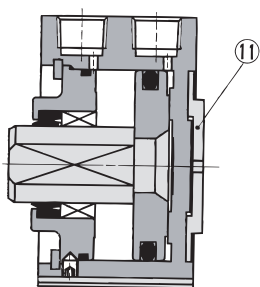

Rod end male thread

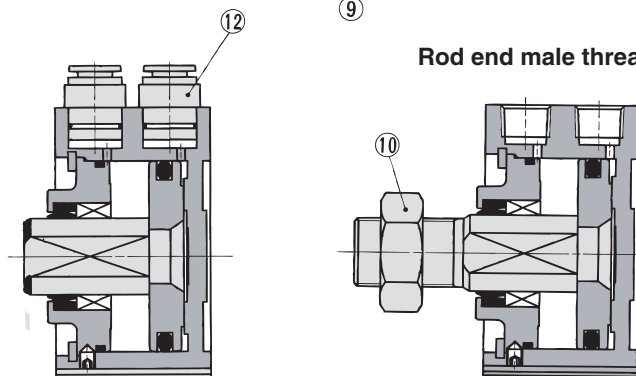

Component Parts

No.	Description	Material	Note
①	Cylinder tube	Aluminum alloy	Hard anodized
②	Piston	Aluminum alloy	Chromated
③	Piston rod	Stainless steel	ϕ 12 to ϕ 25
		Carbon steel	ϕ 32 to ϕ 100, Hard chrome plated
④	Rod cover	Brass	ϕ 12, Nickel plated
		Aluminum alloy	ϕ 16 to ϕ 32, Anodized
⑤	Collar	Aluminum alloy	ϕ 40 to ϕ 63, Anodized
⑥	Snap ring	Carbon tool steel	Phosphate coated
⑦	Bushing	Oil-impregnated sintered alloy	ϕ 16 to ϕ 63
⑧	Hexagon socket head cap screw	Alloy steel	ϕ 12 to ϕ 32, Nickel plated
⑨	Hexagon socket head set screw	Alloy steel	ϕ 40 to ϕ 63, Nickel plated
⑩	Rod end nut	Carbon steel	Nickel plated
⑪	Centering location ring	Aluminum alloy	ϕ 20 to ϕ 63, Hard anodized
⑫	One-touch fitting	—	ϕ 32 to ϕ 63

No.	Description	Material	Note
⑬	Piston seal	NBR	
⑭	Rod seal	NBR	
⑮	Tube gasket	NBR	

Replacement Parts: Seal Kit

Bore size (mm)	Kit no.	Note	Bore size (mm)	Kit no.	Note
12	CQ2KB12-PS	Nos. above ⑬, ⑭, ⑮	32	CQ2KB32-PS	Nos. above ⑬, ⑭, ⑮
16	CQ2KB16-PS		40	CQ2KB40-PS	
20	CQ2KB20-PS		50	CQ2KB50-PS	
25	CQ2KB25-PS		63	CQ2KB63-PS	

CUJ

CU

CQS

CQM

CQ2

RQ

MU

D-

-X

20-

Data

Series CQ2K

Mounting Bolt for CQ2KB

Mounting method: Mounting bolt for through-hole mounting style of CQ2KB is available as an option.

Ordering: Add the word "Bolt" in front of the bolts to be used.

Example) Bolt M3 x 30ℓ 2 pcs.

Model	C	D	Mounting bolt	C'	D'	Mounting bolt
CQ2KB12-5D	6.5	30	M3 x 30ℓ	6.5	30	M3 x 30ℓ
-10D		35	x 35ℓ		35	x 35ℓ
-15D		40	x 40ℓ		40	x 40ℓ
-20D		45	x 45ℓ		45	x 45ℓ
-25D		50	x 50ℓ		50	x 50ℓ
-30D		55	x 55ℓ		55	x 55ℓ
CQ2KB16-5D	5	30	M3 x 30ℓ	5	30	M3 x 30ℓ
-10D		35	x 35ℓ		35	x 35ℓ
-15D		40	x 40ℓ		40	x 40ℓ
-20D		45	x 45ℓ		45	x 45ℓ
-25D		50	x 50ℓ		50	x 50ℓ
-30D		55	x 55ℓ		55	x 55ℓ
CQ2KB20-5D	8	35	M5 x 35ℓ	9.5	35	M5 x 35ℓ
-10D		40	x 40ℓ		40	x 40ℓ
-15D		45	x 45ℓ		45	x 45ℓ
-20D		50	x 50ℓ		50	x 50ℓ
-25D		55	x 55ℓ		55	x 55ℓ
-30D		60	x 60ℓ		60	x 60ℓ
-35D		65	x 65ℓ		65	x 65ℓ
-40D		70	x 70ℓ		70	x 70ℓ
-45D		75	x 75ℓ		75	x 75ℓ
-50D		80	x 80ℓ		80	x 80ℓ
CQ2KB25-5D	10	40	M5 x 40ℓ	6.5	35	M5 x 35ℓ
-10D		45	x 45ℓ		40	x 40ℓ
-15D		50	x 50ℓ		45	x 45ℓ
-20D		55	x 55ℓ		50	x 50ℓ
-25D		60	x 60ℓ		55	x 55ℓ
-30D		65	x 65ℓ		60	x 60ℓ
-35D		70	x 70ℓ		65	x 65ℓ
-40D		75	x 75ℓ		70	x 70ℓ
-45D		80	x 80ℓ		75	x 75ℓ
-50D		85	x 85ℓ		80	x 80ℓ
CQ2KB32-5D	8.5	40	M5 x 40ℓ	10	40	M5 x 40ℓ
-10D		45	x 45ℓ		45	x 45ℓ
-15D		50	x 50ℓ		50	x 50ℓ
-20D		55	x 55ℓ		55	x 55ℓ
-25D		60	x 60ℓ		60	x 60ℓ
-30D		65	x 65ℓ		65	x 65ℓ
-35D		70	x 70ℓ		70	x 70ℓ
-40D		75	x 75ℓ		75	x 75ℓ
-45D		80	x 80ℓ		80	x 80ℓ
-50D		85	x 85ℓ		85	x 85ℓ
-75D	120	x 120ℓ	120	x 120ℓ		
-100D	145	x 145ℓ	145	x 145ℓ		

Head side mounting style

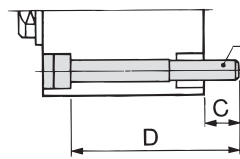

Rod side mounting style

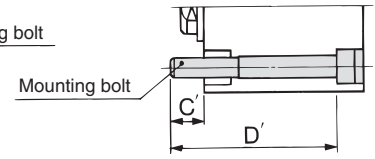

Model	C	D	Mounting bolt	C'	D'	Mounting bolt
CQ2KB40-5D	7.5	35	M5 x 35ℓ	7.5	35	M5 x 35ℓ
-10D		40	x 40ℓ		40	x 40ℓ
-15D		45	x 45ℓ		45	x 45ℓ
-20D		50	x 50ℓ		50	x 50ℓ
-25D		55	x 55ℓ		55	x 55ℓ
-30D		60	x 60ℓ		60	x 60ℓ
-35D		65	x 65ℓ		65	x 65ℓ
-40D		70	x 70ℓ		70	x 70ℓ
-45D		75	x 75ℓ		75	x 75ℓ
-50D		80	x 80ℓ		80	x 80ℓ
-75D	115	x 115ℓ	115	x 115ℓ		
-100D	140	x 140ℓ	140	x 140ℓ		
CQ2KB50-10D	12.5	45	M6 x 45ℓ	12.5	45	M6 x 45ℓ
-15D		50	x 50ℓ		50	x 50ℓ
-20D		55	x 55ℓ		55	x 55ℓ
-25D		60	x 60ℓ		60	x 60ℓ
-30D		65	x 65ℓ		65	x 65ℓ
-35D		70	x 70ℓ		70	x 70ℓ
-40D		75	x 75ℓ		75	x 75ℓ
-45D		80	x 80ℓ		80	x 80ℓ
-50D		85	x 85ℓ		85	x 85ℓ
-75D		120	x 120ℓ		120	x 120ℓ
-100D	145	x 145ℓ	145	x 145ℓ		
CQ2KB63-10D	14.5	50	M8 x 50ℓ	14.5	50	M8 x 50ℓ
-15D		55	x 55ℓ		55	x 55ℓ
-20D		60	x 60ℓ		60	x 60ℓ
-25D		65	x 65ℓ		65	x 65ℓ
-30D		70	x 70ℓ		70	x 70ℓ
-35D		75	x 75ℓ		75	x 75ℓ
-40D		80	x 80ℓ		80	x 80ℓ
-45D		85	x 85ℓ		85	x 85ℓ
-50D		90	x 90ℓ		90	x 90ℓ
-75D		125	x 125ℓ		125	x 125ℓ
-100D	150	x 150ℓ	150	x 150ℓ		

Copper-free (For CRT manufacturing process)

20 — CQ2KB Bore size — Stroke D(M)
 • Copper-free — • ø16, ø20, ø25, ø32, ø40, ø50, ø63

To prevent the influence of copper ions or halogen ions during CRT manufacturing processes, copper and fluorine materials are not used in the component parts.

Specifications

Action	Double acting, Single rod
Bore size (mm)	16, 20, 25, 32, 40, 50, 63
Proof pressure	1.5 MPa
Maximum operating pressure	1.0 MPa
Rubber bumper	None
Piping	Screw-in piping
Piston speed	50 to 500 mm/s
Mounting	Through-hole
Auto switch	Mountable

Series CDQ2K

Mounting Bolt for CDQ2KB with Auto Switch

Mounting method: Mounting bolt for through-hole mounting style of CDQ2KB is available as an option.

Ordering: Add the word "Bolt" in front of the bolts to be used.

Example) Bolt M3 x 35 ℓ 2 pcs.

Head side mounting style

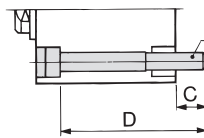

Rod side mounting style

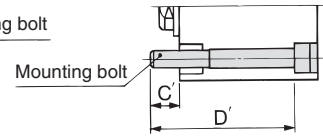

Model	C	D	Mounting bolt	C'	D'	Mounting bolt
CDQ2KB12-5DC	5.5	35	M3 x 35 ℓ	5.5	40	M3 x 40 ℓ
-10DC		40	x 40 ℓ		45	x 45 ℓ
-15DC		45	x 45 ℓ		50	x 50 ℓ
-20DC		50	x 50 ℓ		55	x 55 ℓ
-25DC		55	x 55 ℓ		60	x 60 ℓ
-30DC		60	x 60 ℓ		65	x 65 ℓ
CDQ2KB16-5D	8	40	M3 x 40 ℓ	8	45	M3 x 45 ℓ
-10D		45	x 45 ℓ		50	x 50 ℓ
-15D		50	x 50 ℓ		55	x 55 ℓ
-20D		55	x 55 ℓ		60	x 60 ℓ
-25D		60	x 60 ℓ		65	x 65 ℓ
-30D		65	x 65 ℓ		70	x 70 ℓ
CDQ2KB20-5D	10.5	40	M5 x 40 ℓ	7.5	45	M5 x 45 ℓ
-10D		45	x 45 ℓ		50	x 50 ℓ
-15D		50	x 50 ℓ		55	x 55 ℓ
-20D		55	x 55 ℓ		60	x 60 ℓ
-25D		60	x 60 ℓ		65	x 65 ℓ
-30D		65	x 65 ℓ		70	x 70 ℓ
-35D	70	x 70 ℓ	75	x 75 ℓ		
-40D	75	x 75 ℓ	80	x 80 ℓ		
-45D	80	x 80 ℓ	85	x 85 ℓ		
-50D	85	x 85 ℓ	90	x 90 ℓ		
CDQ2KB25-5D	9.5	40	M5 x 40 ℓ	6.5	45	M5 x 45 ℓ
-10D		45	x 45 ℓ		50	x 50 ℓ
-15D		50	x 50 ℓ		55	x 55 ℓ
-20D		55	x 55 ℓ		60	x 60 ℓ
-25D		60	x 60 ℓ		65	x 65 ℓ
-30D		65	x 65 ℓ		70	x 70 ℓ
-35D	70	x 70 ℓ	75	x 75 ℓ		
-40D	75	x 75 ℓ	80	x 80 ℓ		
-45D	80	x 80 ℓ	85	x 85 ℓ		
-50D	85	x 85 ℓ	90	x 90 ℓ		
CDQ2KB32-5D	8.5	50	M5 x 50 ℓ	10	50	M5 x 50 ℓ
-10D		55	x 55 ℓ		55	x 55 ℓ
-15D		60	x 60 ℓ		60	x 60 ℓ
-20D		65	x 65 ℓ		65	x 65 ℓ
-25D		70	x 70 ℓ		70	x 70 ℓ
-30D		75	x 75 ℓ		75	x 75 ℓ
-35D	80	x 80 ℓ	80	x 80 ℓ		

Model	C	D	Mounting bolt	C'	D'	Mounting bolt
CDQ2KB32-40D	8.5	85	M5 x 85 ℓ	10	85	M5 x 85 ℓ
-45D		90	x 90 ℓ		90	x 90 ℓ
-50D		95	x 95 ℓ		95	x 95 ℓ
-75D		120	x 120 ℓ		120	x 120 ℓ
-100D		145	x 145 ℓ		145	x 145 ℓ
CDQ2KB40-5D		7.5	45		M5 x 45 ℓ	7.5
-10D	50		x 50 ℓ	50	x 50 ℓ	
-15D	55		x 55 ℓ	55	x 55 ℓ	
-20D	60		x 60 ℓ	60	x 60 ℓ	
-25D	65		x 65 ℓ	65	x 65 ℓ	
-30D	70		x 70 ℓ	70	x 70 ℓ	
-35D	75	x 75 ℓ	75	x 75 ℓ		
-40D	80	x 80 ℓ	80	x 80 ℓ		
-45D	85	x 85 ℓ	85	x 85 ℓ		
-50D	90	x 90 ℓ	90	x 90 ℓ		
-75D	115	x 115 ℓ	115	x 115 ℓ		
-100D	140	x 140 ℓ	140	x 140 ℓ		
CDQ2KB50-10D	12.5	55	M6 x 55 ℓ	12.5	55	M6 x 55 ℓ
-15D		60	x 60 ℓ		60	x 60 ℓ
-20D		65	x 65 ℓ		65	x 65 ℓ
-25D		70	x 70 ℓ		70	x 70 ℓ
-30D		75	x 75 ℓ		75	x 75 ℓ
-35D		80	x 80 ℓ		80	x 80 ℓ
-40D	85	x 85 ℓ	85	x 85 ℓ		
-45D	90	x 90 ℓ	90	x 90 ℓ		
-50D	95	x 95 ℓ	95	x 95 ℓ		
-75D	120	x 120 ℓ	120	x 120 ℓ		
-100D	145	x 145 ℓ	145	x 145 ℓ		
CDQ2KB63-10D	14.5	60	M8 x 60 ℓ	14.5	60	M8 x 60 ℓ
-15D		65	x 65 ℓ		65	x 65 ℓ
-20D		70	x 70 ℓ		70	x 70 ℓ
-25D		75	x 75 ℓ		75	x 75 ℓ
-30D		80	x 80 ℓ		80	x 80 ℓ
-35D		85	x 85 ℓ		85	x 85 ℓ
-40D	90	x 90 ℓ	90	x 90 ℓ		
-45D	95	x 95 ℓ	95	x 95 ℓ		
-50D	100	x 100 ℓ	100	x 100 ℓ		
-75D	125	x 125 ℓ	125	x 125 ℓ		
-100D	150	x 150 ℓ	150	x 150 ℓ		

Auto Switch Mounting Bracket Part No.

Bore size (mm)	Mounting bracket part no.	Note	Applicable auto switch	
			Reed switch	Solid state switch
12, 16 20, 25	BQ-1	<ul style="list-style-type: none"> Switch mounting screw (M3 x 0.5 x 8ℓ) Square nut 	D-A7□/A80 D-A73C/A80C	D-F7□/J79 D-F7□V D-J79C
32, 40 50, 63 80, 100	BQ-2	<ul style="list-style-type: none"> Switch mounting screw (M3 x 0.5 x 10ℓ) Switch spacer Switch mounting nut 	D-A7□H/A80H D-A79W	D-F7□W/J79W D-F7□WV D-F7BAL/F7BAVL D-F79F D-F7NTL
40 to 100	BQP1-050	<ul style="list-style-type: none"> Switch mounting bracket Switch mounting nut Hexagon hole cap bolt (M3 x 0.5 x 14ℓ spring washer 2 pcs.) Round head Phillips screw (M3 x 0.5 x 16ℓ spring washer 2 pcs.) 	—	D-P5DWL

[Mounting screws set made of stainless steel]

The set of stainless steel mounting screws (with nuts) described below is available and can be used depending on the operating environment.

(Since the spacer is not included, order it separately.)

BBA2: For D-A7/A8/F7/J7

"D-F7BAL/F7BAVL" switch is set on the cylinder with the stainless steel screws above when shipped.

When only a switch is shipped independently, "BBA2" screws are attached.

Compact Cylinder with Auto Switch: Non-rotating Rod Type Double Acting, Single Rod Series **CDQ2K**

Proper Auto Switch Mounting Position (Detection at stroke end) and Its Mounting Height

	D-A7□ D-A80	D-A7□H D-A80H D-F7□ D-J79 D-F7BAL	D-F7□W D-J79W D-F79F D-F7NTL	D-A73C D-A80C D-J79C	D-A79W D-F7□WV D-F7□V D-F7BAVL		
ø12 to ø25						<div style="border: 1px solid black; padding: 2px; margin-bottom: 2px;">CUJ</div> <div style="border: 1px solid black; padding: 2px; margin-bottom: 2px;">CU</div> <div style="border: 1px solid black; padding: 2px; margin-bottom: 2px;">CQS</div> <div style="border: 1px solid black; padding: 2px; margin-bottom: 2px;">CQM</div> <div style="border: 1px solid black; padding: 2px; margin-bottom: 2px; background-color: #333; color: white;">CQ2</div> <div style="border: 1px solid black; padding: 2px; margin-bottom: 2px;">RQ</div> <div style="border: 1px solid black; padding: 2px; margin-bottom: 2px;">MU</div> <div style="border: 1px solid black; padding: 2px; margin-bottom: 2px;">D-</div> <div style="border: 1px solid black; padding: 2px; margin-bottom: 2px;">-X</div> <div style="border: 1px solid black; padding: 2px; margin-bottom: 2px;">20-</div> <div style="border: 1px solid black; padding: 2px;">Data</div>	
ø32 to ø63							
ø32 to ø63	D-A9□ D-M9□ D-F9□W	D-A9□V D-M9□V D-F9□WV	D-F9BAL				
ø40 to ø63							
	D-P5DWL						

Proper Auto Switch Mounting Position

Bore size (mm)	D-A7□ D-A80		D-A7□H/A80H D-A73C/A80C D-F7□/J79/J79W/F79F D-F7□V/J79C D-F7□W/F7□WV D-F7BAL/F7BAVL		D-A79W		D-A9□ D-A9□V		D-M9□ D-M9□V D-F9□W D-F9□WV		D-F9BAL		D-P5DWL	
	A	B	A	B	A	B	A	B	A	B	A	B	A	B
12	9.5	5.5	10	6	7	3	—	—	—	—	—	—	—	—
16	12.5	5	13	5.5	10	2.5	—	—	—	—	—	—	—	—
20	15.5	6.5	16	7	13	4	—	—	—	—	—	—	—	—
25	15.5	7	16	7.5	13	4.5	—	—	—	—	—	—	—	—
32	18	6	18.5	6.5	15.5	3.5	17	5	21	9	20	8	—	—
40	13	8.5	13.5	9	10.5	6	12	7.5	16	11.5	15	10.5	9	4.5
50	11	11.5	11.5	12	8.5	9	10	10.5	14	14.5	13	13.5	7	7.5
63	13.5	14.5	14	15	11	12	12.5	13.5	16.5	17.5	15.5	16.5	9.5	10.5

Auto Switch Mounting Height

Bore size (mm)	D-A7□ D-A80	D-A7□H/A80H/F7□ D-J79/F7□W/J79W D-F7BAL/F79F/F7NTL	D-A73C D-A80C	D-F7□V D-F7□WV D-F7BAVL	D-J79C	D-A79W	D-A9□V	D-M9□V D-F9□WV	D-F9BAL	D-P5DWL
	U	U	U	U	U	U	U	U	U	U
12	19.5	20.5	26.5	23	26	22	—	—	—	—
16	22.5	23.5	29.5	26	29	25	—	—	—	—
20	24.5	25.5	31.5	28	31	27	—	—	—	—
25	27.5	28.5	34.5	31	34	30	—	—	—	—
32	31.5	32.5	38.5	35	38	34	27	29	26.5	—
40	35	36	42	38.5	41.5	37.5	30.5	32.5	30	44
50	41	42	48	44.5	47.5	43.5	36.5	38.5	36	50
63	47.5	48.5	54.5	51	54	50	40	42	39.5	56.5

Series CQ2K

Dimensions: $\phi 12$ to $\phi 25$ /Without Auto Switch

Basic style (Through-hole): CQ2KB

$\phi 12, \phi 16$

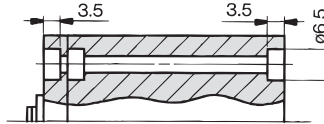

$\phi 20, \phi 25$

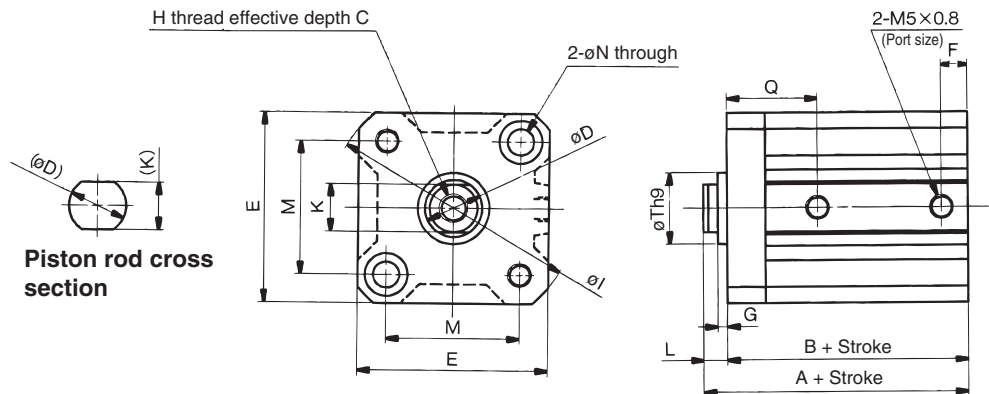
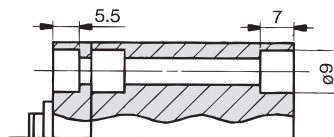

With boss in head side

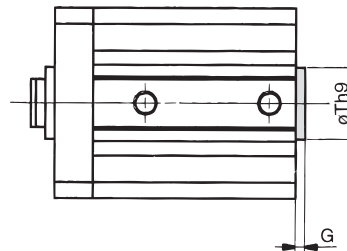

With Boss in Head Side

Bore size (mm)	G	Th9
12	1.5	15 ⁰ _{-0.043}
16	1.5	20 ⁰ _{-0.052}
20	2	13 ⁰ _{-0.043}
25	2	15 ⁰ _{-0.043}

Rod end male thread

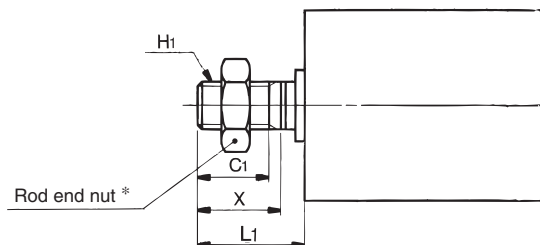

Rod End Male Thread

Bore size (mm)	C1	H1	L1	X
12	9	M5 x 0.8	14	10.5
16	10	M6 x 1.0	15.5	12
20	12	M8 x 1.25	18.5	14
25	15	M10 x 1.25	22.5	17.5

Basic Style

Bore size (mm)	Stroke range (mm)	A	B	C	D	E	F	G	H	I	K	L	M	N	Q	Th9
12	5 to 30	25.5	22	6	6	25	5	1.5	M3 x 0.5	32	5.2	3.5	15.5	3.5	12.5	15 ⁰ _{-0.043}
16	5 to 30	27	23.5	8	8	29	5.5	1.5	M4 x 0.7	38	6	3.5	20	3.5	13	20 ⁰ _{-0.052}
20	5 to 50	32	27.5	7	10	36	5.5	2	M5 x 0.8	47	8	4.5	25.5	5.5	17	13 ⁰ _{-0.043}
25	5 to 50	35.5	30.5	12	12	40	5.5	2	M6 x 1.0	52	10	5	28	5.5	19	15 ⁰ _{-0.043}



* For details about the rod end nut and accessory brackets, refer to page 7-6-20.

Compact Cylinder: Non-rotating Rod Type Double Acting, Single Rod Series CQ2K

Dimensions: $\phi 12$ to $\phi 25$ /With Auto Switch

Basic Style (Through-hole): CDQ2KB

$\phi 12, \phi 16$

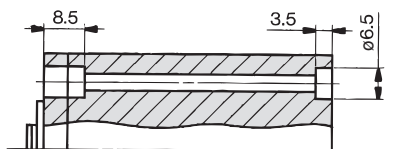

$\phi 20, \phi 25$

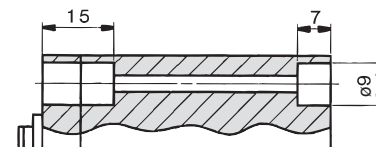

Minimum lead wire bending radius 10

Auto switch

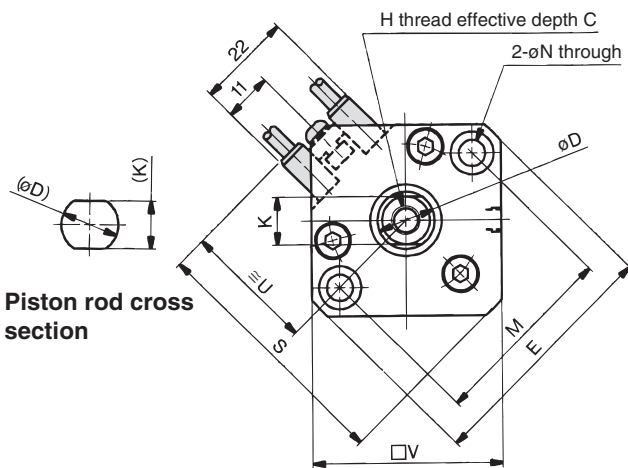

Piston rod cross section

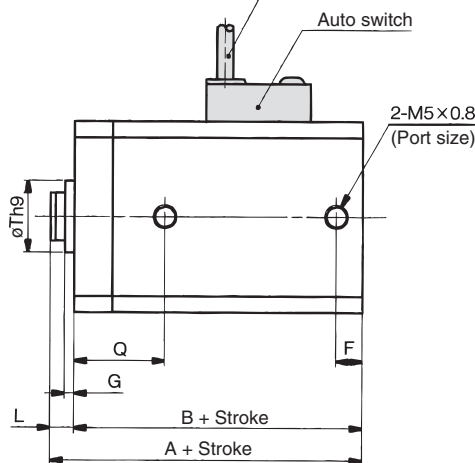

With boss in head side

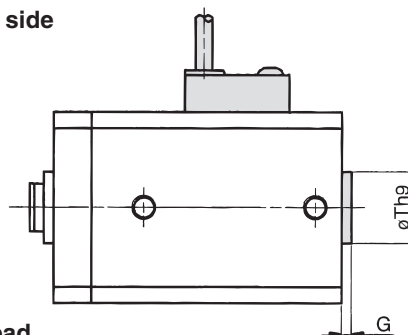

Rod end male thread

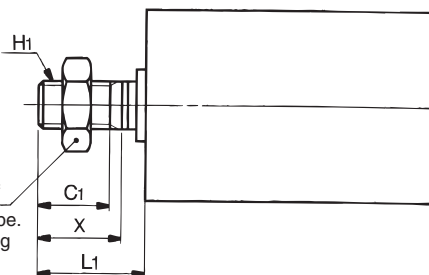

Rod end nut *

Rod End Male Thread

Bore size (mm)	C1	H1	L1	X
12	9	M5 x 0.8	14	10.5
16	10	M6 x 1.0	15.5	12
20	12	M8 x 1.25	18.5	14
25	15	M10 x 1.25	22.5	17.5



* Auto switch shown above is D-A73 type and DA80 type. For the auto switch mounting position and its mounting height, refer to page 7-6-69.

Basic Style

Bore size (mm)	Stroke range (mm)	A	B	C	D	E	F	G	H	K	L	M	N	Q	S	Th9	U	V
12	5 to 30	36.5	33	6	6	32	6.5	1.5	M3 x 0.5	5.2	3.5	22	3.5	16	35.5	15 ⁰ _{-0.043}	19.5	25
16	5 to 30	39	35.5	8	8	38	5.5	1.5	M4 x 0.7	6	3.5	28	3.5	15	41.5	20 ⁰ _{-0.052}	22.5	29
20	5 to 50	44	39.5	7	10	47	5.5	2	M5 x 0.8	8	4.5	36	5.5	18.5	48	13 ⁰ _{-0.043}	24.5	36
25	5 to 50	45.5	40.5	12	12	52	5.5	2	M6 x 1.0	10	5	40	5.5	19	53.5	15 ⁰ _{-0.043}	27.5	40



* For details about the rod end nut and accessory brackets, refer to page 7-6-20.

CUJ

CU

CQS

CQM

CQ2

RQ

MU

D-

-X

20-

Data

Series CDQ2K

Dimensions: $\phi 32$ /Without Auto Switch

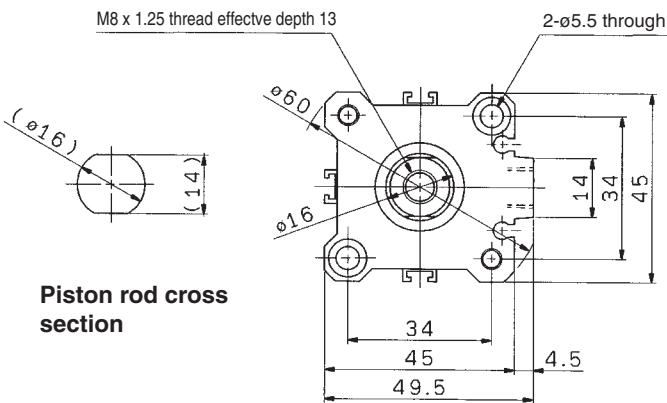
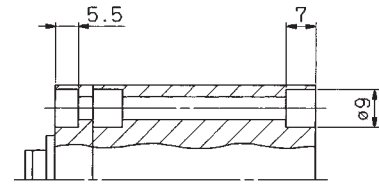

Piston rod cross section

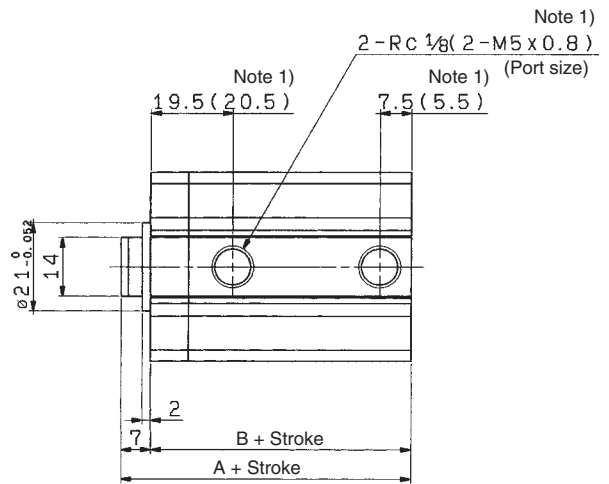

Note 1) () : denotes at stroke 5 mm

Stroke range	A	B
5 to 50	39	32
75, 100	49	42

(mm)

With boss in head side

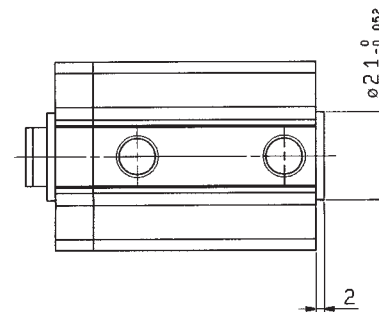

Rod end male thread

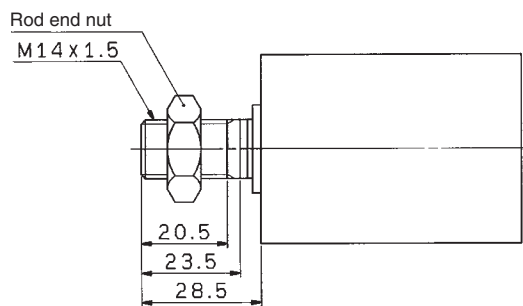

Built-in One-touch fittings: $\phi 32$

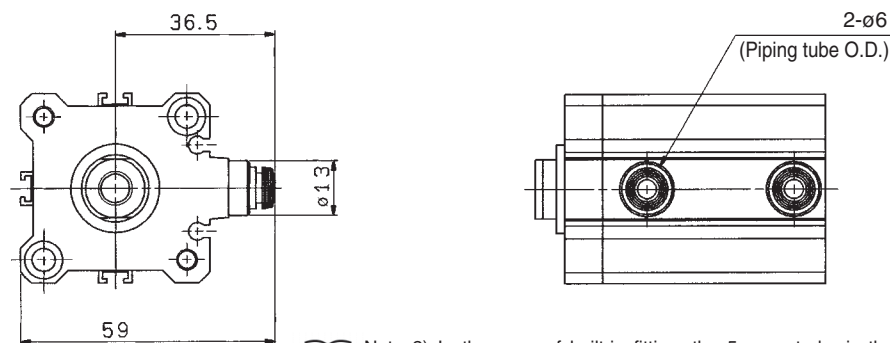

Note 2) In the case of built-in fitting, the 5 mm stroke is the same external dimensions as 10 mm stroke.
* For details about the rod end nut and accessory brackets, refer to page 7-6-20.

Compact Cylinder with Auto Switch: Non-rotating Rod Type Double Acting, Single Rod Series **CDQ2K**

Dimensions: $\phi 32$ /With Auto Switch

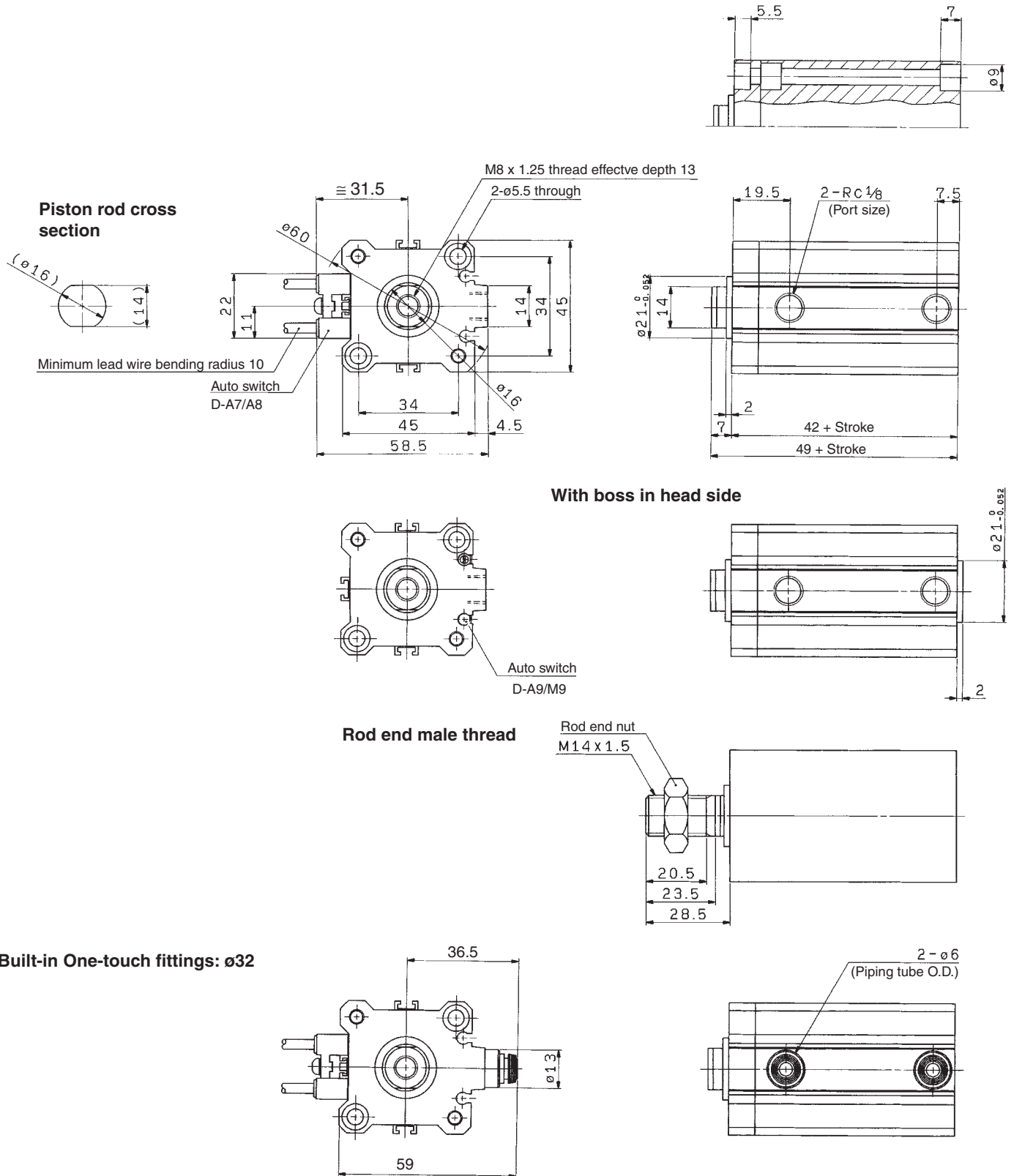

CUJ

CU

CQS

CQM

CQ2

RQ

MU

D-

-X

20-

Data



* For details about the rod end nut and accessory brackets, refer to page 7-6-20.

Series CQ2K/CDQ2K

(In the case of without auto switches, A and B dimensions will be only changed. Refer to the dimension chart.)

Dimensions: ø40 to ø63/With Auto Switch

Basic style (Through-hole): CDQ2KB

Both ends tapped style: CDQ2KA

Both Ends Tapped Style

Bore size (mm)	O ₁	R
40	M6 x 1.0	10
50	M8 x 1.25	14
63	M10 x 1.5	18

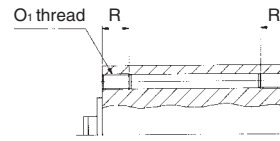

Piston rod cross section

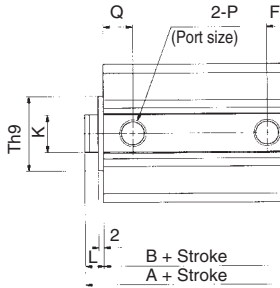
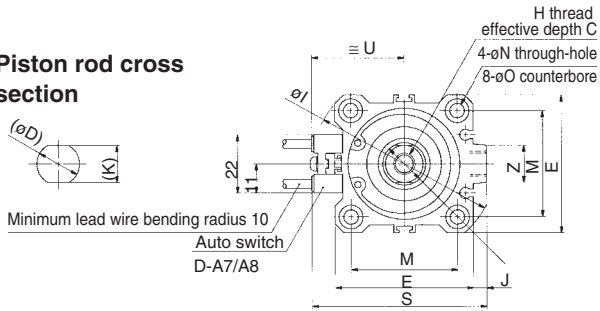

With boss in head side

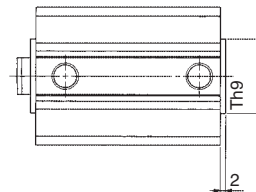
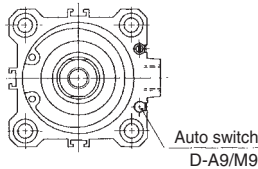

With Boss in Head Side

Bore size (mm)	Th9
40	28 ⁰ _{-0.052}
50	35 ⁰ _{-0.062}
63	35 ⁰ _{-0.062}

Rod end male thread

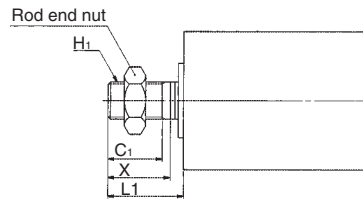
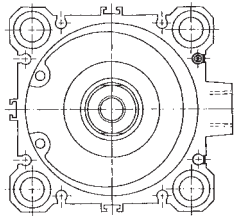

ø63 Cylinder tube form

Rod End Male Thread

Bore size (mm)	C ₁	H ₁	L ₁	X
40	20.5	M14 x 1.5	28.5	23.5
50	26	M18 x 1.5	33.5	28.5
63	26	M18 x 1.5	33.5	28.5

Built-in One-touch fittings

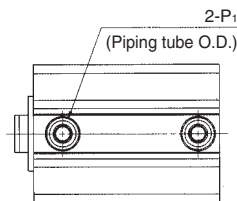
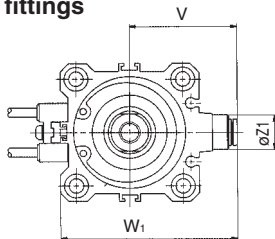

Built-in One-touch Fittings

Bore size (mm)	Z ₁	P ₁	V	W ₁
40	13	6	40.5	66.5
50	16	8	50	82
63	16	8	56.5	95

Basic Style

Bore size (mm)	Stroke range (mm)	Without auto switch		With auto switch		C	D	E	F	H	I	J	K	L	M	N	O	P	Q	S	Th9	U	Z
		A	B	A	B																		
40	5 to 50	36.5	29.5	46.5	39.5	13	16	52	8	M8 x 1.25	69	5	14	7	40	5.5	9 depth 7	Rc 1/8	11	66	28 ⁰ _{-0.052}	35	14
	75, 100	46.5	39.5																				
50	10 to 50	38.5	30.5	48.5	40.5	15	20	64	10.5	M10 x 1.5	86	7	18	8	50	6.6	11 depth 8	Rc 1/4	10.5	80	35 ⁰ _{-0.062}	41	19
	75, 100	48.5	40.5																				
63	10 to 50	44	36	54	46	15	20	77	10.5	M10 x 1.5	103	7	18	8	60	9	14 depth 10.5	Rc 1/4	15	93	35 ⁰ _{-0.062}	47.5	19
	75, 100	54	46																				

* For details about the rod end nut and accessory brackets, refer to page 7-6-20.

Compact Cylinder: Non-rotating Rod Type Double Acting, Single Rod Series CQ2K/CDQ2K

Foot style: CQ2KL/CDQ2KL

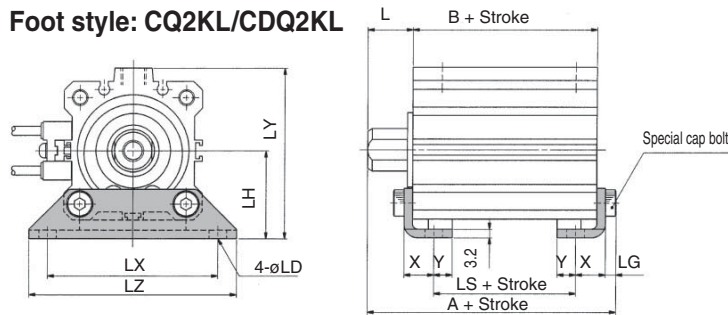

Rod end male thread

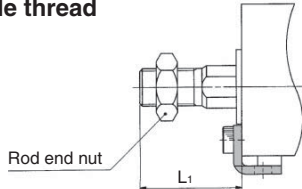

Rod side flange style: CQ2KF/CDQ2KF

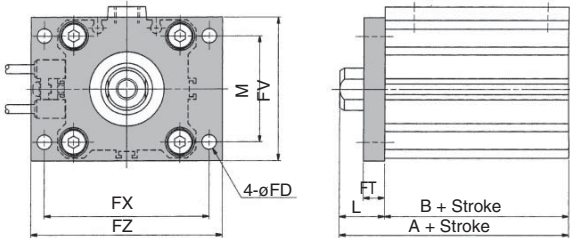

Rod end male thread

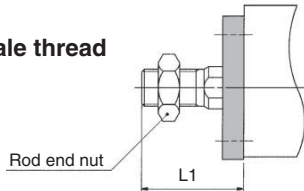

Head side flange style: CQ2KG/CDQ2KG

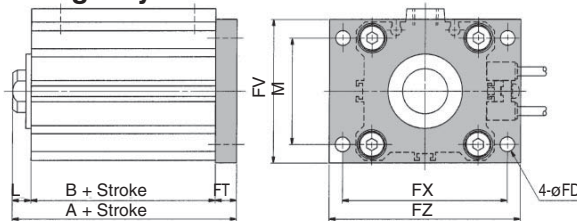

Rod end male thread

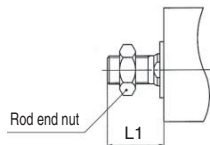

Double clevis style: CQ2KD/CDQ2KD

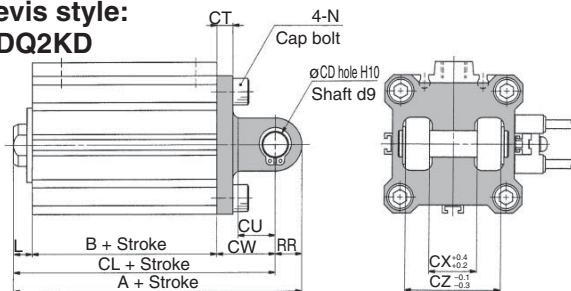

Rod end male thread

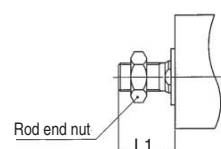

Foot Style

Bore size (mm)	Stroke range (mm)	Without auto switch			With auto switch			L	L1	LD	LG	LH	LX	LY
		A	B	LS	A	B	LS							
40	5 to 50	53.7	29.5	13.5	63.7	39.5	23.5	17	38.5	6.6	4	33	64	64
	75, 100	63.7	39.5	23.5										
50	10 to 50	56.7	30.5	7.5	66.7	40.5	17.5	18	43.5	9	5	39	79	78
	75, 100	66.7	40.5	17.5										
63	10 to 50	62.2	36	10	72.2	46	20	18	43.5	11	5	46	95	91.5
	75, 100	72.2	46	20										

Bore size (mm)	LZ	X	Y
40	78	11.2	7
50	95	14.7	8
63	113	16.2	9

Foot bracket material:
Carbon steel

Rod Side Flange Style

Bore size (mm)	Stroke range (mm)	Without auto switch		With auto switch		FD	FT	FV	FX	FZ	L	L1	M
		A	B	A	B								
40	5 to 50	46.5	29.5	56.5	39.5	5.5	8	54	62	72	17	38.5	40
	75, 100	56.5	39.5										
50	10 to 50	48.5	30.5	58.5	40.5	6.6	9	67	76	89	18	43.5	50
	75, 100	58.5	40.5										
63	10 to 50	54	36	64	46	9	9	80	92	108	18	43.5	60
	75, 100	64	46										

Flange bracket material: Carbon steel

Head Side Flange Style

Bore size (mm)	Stroke range (mm)	Without auto switch	With auto switch	L	L1
		A	A		
40	5 to 50	44.5	54.5	7	28.5
	75, 100	54.5			
50	10 to 50	47.5	57.5	8	33.5
	75, 100	57.5			
63	10 to 50	53	63	8	33.5
	75, 100	63			

* Dimensions except A, L and L1 are the same as rod side flange style.

Flange bracket material: Carbon steel

Double Clevis Style

Bore size (mm)	Stroke range (mm)	Without auto switch			With auto switch			CD	CT	CU	CW	CX	CZ	L	L1
		A	B	CL	A	B	CL								
40	5 to 50	68.5	29.5	58.5	78.5	39.5	68.5	10	6	14	22	18	36	7	28.5
	75, 100	78.5	39.5	68.5											
50	10 to 50	80.5	30.5	66.5	90.5	40.5	76.5	14	7	20	28	22	44	8	33.5
	75, 100	90.5	40.5	76.5											
63	10 to 50	88	36	74	98	46	84	14	8	20	30	22	44	8	33.5
	75, 100	98	46	84											

Double clevis bracket material: Carbon steel



* For details about the rod end nut and accessory brackets, refer to page 7-6-20.

** Clevis pin and snap ring are shipped together.

CUJ

CU

CQS

CQM

CQ2

RQ

MU

D-

-X

20-

Data



Compact Cylinder: Non-rotating Rod Type Double Acting, Double Rod

Series CQ2KW

ø12, ø16, ø20, ø25, ø32, ø40, ø50, ø63

How to Order

Without auto switch

CQ2KW B 20 30 D

With auto switch

CDQ2KW B 20 30 D J79W S

Built-in magnet

Mounting style

B	Through-hole (Standard)	ø12 to ø63
A	Both ends tapped style	
L	Foot style	ø40 to ø63
F	Flange style	

* Mounting brackets are shipped together, (but not assembled).

Bore size

12	12 mm
16	16 mm
20	20 mm
25	25 mm
32	32 mm
40	40 mm
50	50 mm
63	63 mm

Piping

Nil	Screw-in piping
F	Built-in One-touch fittings <small>Note)</small>

Note) Bore sizes available w/ One-touch fittings are ø32 to ø63.

Auto switch

Nil	Without auto switch (Built-in magnet)	Nil	2 pcs.
S		S	1 pc.
n		n	"n" pcs.

* For the applicable auto switch model, refer to the table below.
* Auto switches are shipped together, (but not assembled). (Except D-P5DWL)

Body option

Nil	Standard (Rod end female thread)
C	With rubber bumper (Only ø12 with switch)
M	Rod end male thread

Action

D	Double acting
----------	---------------

Cylinder stroke (mm)
Refer to "Standard Stroke" on page 7-6-77.

Applicable Auto Switch/Refer to page 7-9-1 for further information on auto switches.

Type	Special function	Electrical entry	Indicator/light	Wiring (Output)	Load voltage		Rail mounting		Direct mounting		Lead wire length (m) *				Pre-wire connector	Applicable load			
					DC	AC	ø12 to ø63		ø32 to ø63		0.5 (Nil)	3 (L)	5 (Z)	None (N)		IC circuit	Relay, PLC		
							Perpendicular	In-line	Perpendicular	In-line									
Reed switch	—	Grommet	Yes	3-wire (NPN equivalent)	—	5 V	—	A76H	A96V	A96	●	●	—	—	—	IC circuit	—		
				—	—	200 V	A72	A72H	—	—	●	●	—	—	—	—	Relay, PLC		
	Connector	2-wire		24 V	12 V	100 V	—	—	A93V	A93	●	●	●	—	—			—	—
					—	—	—	A73C	—	—	—	—	●	●	●	●	—	—	—
Solid state switch	—	Grommet	Yes	3-wire (NPN)	5 V, 12 V	—	F7NV	F79	M9NV	M9N	●	●	○	—	○	IC circuit	Relay, PLC		
				3-wire (PNP)			F7PV	F7P	M9PV	M9P	●	●	○	—	○				
	Connector	2-wire		12 V	F7BV		J79	M9BV	M9B	●	●	○	—	○	—	—			
					J79C		—	—	—	●	●	●	●	—	—				
	Diagnostic indication (2-color indication)	Grommet		3-wire (NPN)	5 V, 12 V		F7NVV	F79W	F9NVV	F9NW	—	●	○	—	○	—		IC circuit	
				3-wire (PNP)			—	F7PW	F9PWV	F9PW	●	●	○	—	○				
	Water resistant (2-color indication)	Grommet		2-wire	24 V		12 V	—	F7BWW	J79W	F9BWW	F9BW	●	●	○	—		○	—
									F7BAV	F7BA	—	F9BA	—	●	○	—		○	—
With diagnostic output (2-color indication)	Grommet	4-wire (NPN)	5 V, 12 V	—	—	—	F79F	—	—	●	●	○	—	○	IC circuit				
						Magnetic field resistant (2-color indication)	—	P5DW	—	—	—	●	●	—	○	—			

* Lead wire length symbols: 0.5 m.....Nil (Example) A73C
 3 m.....L (Example) A73CL
 5 m.....Z (Example) A73CZ
 None.....N (Example) A73CN

* Solid state switches marked with "○" are produced upon receipt of order.

- D-P5DWL type is available from ø40 to ø63 only.
- There are other applicable auto switches other than the listed above. For details, refer to page 7-6-23.
- For details about auto switches with pre-wire connector, refer to page 7-9-36.

Compact Cylinder: Non-rotating Rod Type Double Acting, Double Rod Series CQ2KW



JIS Symbol
Non-rotating rod,
Double acting

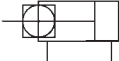

⚠ Precautions

Be sure to read before handling.
For Safety Instructions and
Actuator Precautions, refer to
pages 7-13-3 to 7-13-6.

⚠ Caution

Snap Ring Installation/Removal

- For installation and removal, use an appropriate pair of pliers (tool for installing a type C snap ring).
- Even if a proper plier (tool for installing type C snap ring) is used, it is likely to inflict damage to a human body or peripheral equipment, as a snap ring may be flown out of the tip of a plier (tool for installing a type C snap ring). Be much careful with the popping of a snap ring. Besides, be certain that a snap ring is placed firmly into the groove of rod cover before supplying air at the time of installment.

Mounting

- When removing a load, be sure to secure the wrench flats of the piston rod on the load side.
- If this is done without securing the piston rod on the load side, be aware that the coupled (screwed-in) portion of the piston rod could become loosened.

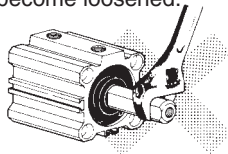

- Using a non-rotating rod cylinder
Avoid using the air cylinder in such a way that rotational torque would be applied to the piston rod. If rotational torque is applied, the non-rotating guide will be deformed, causing a loss of non-rotating accuracy.

Use the chart below as a guide for the allowable rotational torque ranges.

Allowable rotational torque (N·m or less)	ø12	ø16	ø20	ø25	ø32	ø40	ø50	ø63
	0.04	0.15	0.20	0.25	0.44	0.44	0.44	0.44

Operate the cylinder in such a way that the load to the piston rod is always applied in the axial direction.

Type

Bore size (mm)		12	16	20	25	32	40	50	63	
Pneumatic	Mounting	Through-hole (Standard)	●	●	●	●	●	●	●	
		Both ends tapped style	—	—	—	—	—	●	●	●
	Built-in magnet		●	●	●	●	●	●	●	
	Piping	Screw-in type	M5 x 0.8	M5 x 0.8	M5 x 0.8	M5 x 0.8	M5 x 0.8 ⁽¹⁾ Rc 1/8	Rc 1/8	Rc 1/4	Rc 1/4
		Built-in One-touch fittings	—	—	—	—	ø6/4 ⁽²⁾	ø6/4	ø8/6	ø8/6
Rod end male thread		●	●	●	●	●	●	●	●	

Note 1) In the case of without auto switch, M5 x 0.8 is used for 5 stroke only.

Note 2) In the case of built-in fitting, the 5 mm stroke with ø32 bore is the same external dimensions as 10 mm stroke.

Standard Specifications

Type	Pneumatic (Non-lube)
Fluid	Air
Proof pressure	1.5 MPa
Maximum operating pressure	1.0 MPa
Ambient and fluid temperature	Without auto switch: -10 to 70°C (No freezing) With auto switch: -10 to 60°C (No freezing)
Rubber bumper	None ⁽³⁾
Rod end thread	Female thread
Rod end thread tolerance	JIS Class 2
Stroke length tolerance	+1.0 0
Mounting	Through-hole
Piston speed	50 to 500 mm/s

Note 3) ø12, with switch: Rubber bumper is standard.

Minimum Operating Pressure (MPa)

Bore size (mm)	12	16	20	25	32	40	50	63
Minimum operating pressure	0.07	0.07	0.05	0.05	0.05	0.05	0.05	0.05

Non-rotating Accuracy

Bore size (mm)	12	16	20	25	32	40	50	63
Rod non-rotating accuracy	±2°	±1°						±0.8°

Allowable Kinetic Energy

(J)

Bore size (mm)	12	16	20	25	32	40	50	63	80	100
Standard	0.022	0.038	0.055	0.09	0.15	0.26	0.46	0.77	1.36	2.27

Standard Stroke

Bore size (mm)	Standard stroke
12, 16	5, 10, 15, 20, 25, 30
20, 25	5, 10, 15, 20, 25, 30, 35, 40, 45, 50
32, 40	5, 10, 15, 20, 25, 30, 35, 40, 45, 50, 75, 100
50, 63	10, 15, 20, 25, 30, 35, 40, 45, 50, 75, 100

Manufacture of Intermediate Stroke

Description	Spacer is installed in the standard stroke body.	
Part no.	Refer to "How to Order" for the standard model no. on page 7-6-76.	
Description	Dealing with the stroke by the 5 mm interval is available by installing spacer with standard stroke cylinder.	
Stroke range	Bore size (mm)	Stroke range
	32 to 63	55 to 95
Example	Part no.: CQ2KWB50-65D CQ2KWB50-75D with 10 mm width spacer inside. B dimension is 125.5 mm.	

CUJ

CU

CQS

CQM

CQ2

RQ

MU

D-

-X

20-

Data

Series CQ2KW

Theoretical Output

(N)

Bore size (mm)	Operating pressure (MPa)			Bore size (mm)	Operating pressure (MPa)		
	0.3	0.5	0.7		0.3	0.5	0.7
12	25	42	59	32	181	302	422
16	45	75	106	40	317	528	739
20	71	118	165	50	495	825	1150
25	113	189	264	63	841	1400	1960

Mounting Bracket Part No.

Bore size (mm)	Foot ⁽¹⁾	Flange
40	CQ-L040	CQ-F040
50	CQ-L050	CQ-F050
63	CQ-L063	CQ-F063



Note 1) When ordering foot bracket, order 2 pieces per cylinder.

Note 2) Parts belonging to each bracket are as follows.

Compact Cylinder: Non-rotating Rod Type Double Acting, Double Rod Series CQ2KW

Weight (g)

Bore size (mm)	Cylinder stroke (mm)											
	5	10	15	20	25	30	35	40	45	50	75	100
12	62	69	76	83	90	97	—	—	—	—	—	—
16	62	73	84	95	106	117	—	—	—	—	—	—
20	101	116	131	146	161	176	191	206	221	236	—	—
25	138	155	172	189	206	223	240	257	274	291	—	—
32	242	266	290	314	338	362	386	410	434	458	595	715
40	349	380	411	442	473	504	535	566	597	628	879	1034
50	—	548	593	638	683	728	773	818	863	908	1251	1476
63	—	772	811	850	889	928	967	1006	1045	1084	1391	1586

Additional Weight (g)

Bore size (mm)	12	16	20	25	32	40	50	63
Both ends tapped style	—	—	—	—	—	6	6	19
Rod end male thread	Male thread	3	6	12	24	52	54	106
	Nut	2	4	8	16	34	34	64
Built-in One-touch fittings	—	—	—	—	12	12	21	21
Foot style	—	—	—	—	—	155	243	324
Flange style	—	—	—	—	—	214	373	559

Calculation:

(Example) CQ2KWA40-20DM

Cylinder weight: CQ2KWB40-20D..... 442 g

Option weight: Both ends tapped style..... 6 g

Rod end male thread..... 88 g

536 g

Construction

ø12 to ø32

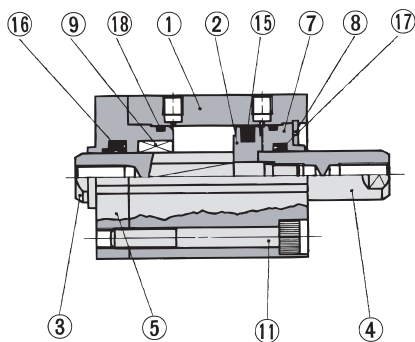

Built-in One-touch fittings

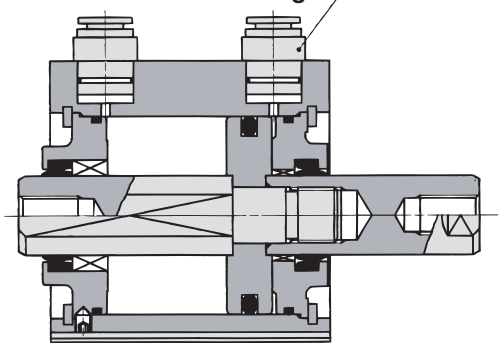

ø40 to ø63

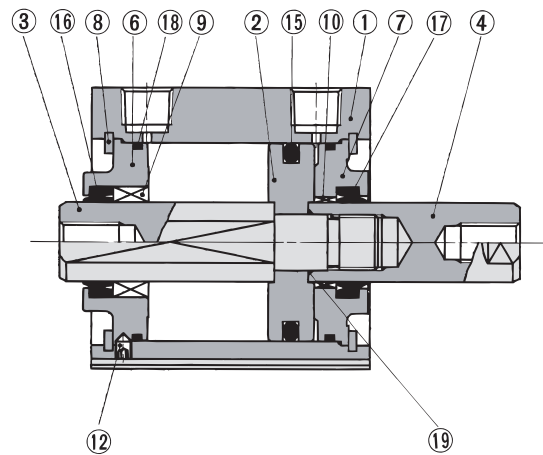

Rod end male thread

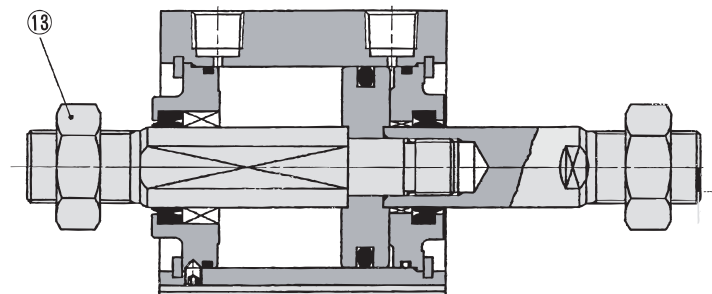

Component Parts

No.	Description	Material	Note
①	Cylinder tube	Aluminum alloy	Hard anodized
②	Piston	Aluminum alloy	Chromated
③	Piston rod A	Stainless steel	ø12 to ø25
		Carbon steel	ø32 to ø63, Hard chrome plated
④	Piston rod B	Stainless steel	ø12 to ø25
		Carbon steel	ø32 to ø63, Hard chrome plated
⑤	Rod cover	Brass	ø12, Nickel plated
		Aluminum alloy	ø16 to ø32, Anodized
⑥	Collar for non-rotating	Aluminum alloy	ø40 to ø63, Anodized
⑦	Collar	Aluminum alloy	ø12 to ø40, Anodized
		Aluminum alloy casted	ø50 to ø63, Chromated, Painted
⑧	Snap ring	Carbon tool steel	Phosphate coated
⑨	Bushing for non-rotating	Oil-impregnated sintered alloy	ø16 to ø63
⑩	Bushing	Lead-bronze casted	ø50, ø63
⑪	Hexagon socket head cap screw	Alloy steel	ø12 to ø32, Nickel plated
⑫	Hexagon socket head set screw	Alloy steel	ø40 to ø63, Nickel plated
⑬	Rod end nut	Carbon steel	Nickel plated
⑭	One-touch fitting	—	ø32 to ø63

No.	Description	Material	Note
⑮	Piston seal	NBR	
⑯	Rod seal for nonrotating	NBR	
⑰	Rod seal	NBR	
⑱	Gasket	NBR	
⑲	Piston gasket	NBR	ø32 to ø63

Replacement Parts: Seal Kit

Bore size (mm)	Kit no.	Note
12	CQ2KWB12-PS	Set of nos. above ⑮, ⑯, ⑰, ⑱
16	CQ2KWB16-PS	
20	CQ2KWB20-PS	
25	CQ2KWB25-PS	
32	CQ2KWB32-PS	
40	CQ2KWB40-PS	
50	CQ2KWB50-PS	
63	CQ2KWB63-PS	

* Seal kit includes ⑮, ⑯, ⑰, ⑱. Order the seal kit, based on each bore size.

CUJ

CU

CQS

CQM

CQ2

RQ

MU

D-

-X

20-

Data

Series CQ2KW

Mounting Bolt for CQ2KWB

Mounting method: Mounting bolt for through-hole mounting style of CQ2KWB is available as an option.

Ordering: Add the word "Bolt" in front of the bolts to be used.
Example) Bolt M3 x 40ℓ 2 pcs.

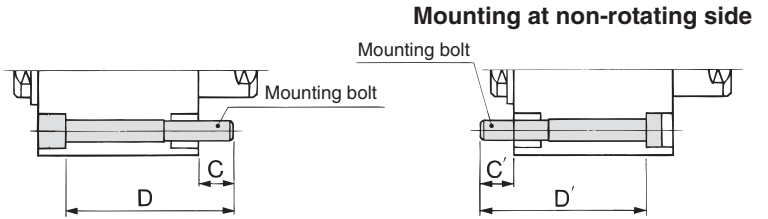

Model	C	D	Mounting bolt	C'	D'	Mounting bolt
CQ2KWB12-5D	8.3	40	M3 x 40ℓ	8.3	40	M3 x 40ℓ
-10D		45	x 45ℓ		45	x 45ℓ
-15D		50	x 50ℓ		50	x 50ℓ
-20D		55	x 55ℓ		55	x 55ℓ
-25D		60	x 60ℓ		60	x 60ℓ
-30D		65	x 65ℓ		65	x 65ℓ
CQ2KWB16-5D	7.5	40	M3 x 40ℓ	7.5	40	M3 x 40ℓ
-10D		45	x 45ℓ		45	x 45ℓ
-15D		50	x 50ℓ		50	x 50ℓ
-20D		55	x 55ℓ		55	x 55ℓ
-25D		60	x 60ℓ		60	x 60ℓ
-30D		65	x 65ℓ		65	x 65ℓ
CQ2KWB20-5D	6.5	40	M5 x 40ℓ	8	40	M5 x 40ℓ
-10D		45	x 45ℓ		45	x 45ℓ
-15D		50	x 50ℓ		50	x 50ℓ
-20D		55	x 55ℓ		55	x 55ℓ
-25D		60	x 60ℓ		60	x 60ℓ
-30D		65	x 65ℓ		65	x 65ℓ
-35D		70	x 70ℓ		70	x 70ℓ
-40D		75	x 75ℓ		75	x 75ℓ
-45D		80	x 80ℓ		80	x 80ℓ
-50D		85	x 85ℓ		85	x 85ℓ
CQ2KWB25-5D	8.5	45	M5 x 45ℓ	10	45	M5 x 45ℓ
-10D		50	x 50ℓ		50	x 50ℓ
-15D		55	x 55ℓ		55	x 55ℓ
-20D		60	x 60ℓ		60	x 60ℓ
-25D		65	x 65ℓ		65	x 65ℓ
-30D		70	x 70ℓ		70	x 70ℓ
-35D		75	x 75ℓ		75	x 75ℓ
-40D		80	x 80ℓ		80	x 80ℓ
-45D		85	x 85ℓ		85	x 85ℓ
-50D		90	x 90ℓ		90	x 90ℓ
CQ2KWB32-5D	11	50	M5 x 50ℓ	7.5	45	M5 x 45ℓ
-10D		55	x 55ℓ		50	x 50ℓ
-15D		60	x 60ℓ		55	x 55ℓ
-20D		65	x 65ℓ		60	x 60ℓ
-25D		70	x 70ℓ		65	x 65ℓ
-30D		75	x 75ℓ		70	x 70ℓ
-35D		80	x 80ℓ		75	x 75ℓ
-40D		85	x 85ℓ		80	x 80ℓ
-45D		90	x 90ℓ		85	x 85ℓ
-50D		95	x 95ℓ		90	x 90ℓ
-75D	130	x 130ℓ	125	x 125ℓ		
-100D	155	x 155ℓ	150	x 150ℓ		

Model	C	D	Mounting bolt
CQ2KWB40-5D	7	45	M5 x 45ℓ
-10D		50	x 50ℓ
-15D		55	x 55ℓ
-20D		60	x 60ℓ
-25D		65	x 65ℓ
-30D		70	x 70ℓ
-35D		75	x 75ℓ
-40D		80	x 80ℓ
-45D		85	x 85ℓ
-50D		90	x 90ℓ
-75D	125	x 125ℓ	
-100D	150	x 150ℓ	
CQ2KWB50-10D	12.5	55	M6 x 55ℓ
-15D		60	x 60ℓ
-20D		65	x 65ℓ
-25D		70	x 70ℓ
-30D		75	x 75ℓ
-35D		80	x 80ℓ
-40D		85	x 85ℓ
-45D		90	x 90ℓ
-50D		95	x 95ℓ
-75D		130	x 130ℓ
-100D	155	x 155ℓ	
CQ2KWB63-10D	13.5	55	M8 x 55ℓ
-15D		60	x 60ℓ
-20D		65	x 65ℓ
-25D		70	x 70ℓ
-30D		75	x 75ℓ
-35D		80	x 80ℓ
-40D		85	x 85ℓ
-45D		90	x 90ℓ
-50D		95	x 95ℓ
-75D		130	x 130ℓ
-100D	155	x 155ℓ	

Copper-free (For CRT manufacturing process)

20 — CQ2KWB Bore size — Stroke D(M)
 • Copper-free • $\phi 16, \phi 20, \phi 25, \phi 32, \phi 40, \phi 50, \phi 63$

To prevent the influence of copper ions or halogen ions during CRT manufacturing processes, copper and fluorine materials are not used in the component parts.

Specifications

Action	Double acting, Double rod
Bore size (mm)	16, 20, 25, 32, 40, 50, 63
Proof pressure	1.5 MPa
Maximum operating pressure	1.0 MPa
Rubber bumper	None
Piping	Screw-in piping
Piston speed	50 to 500 mm/s
Mounting	Through-hole
Auto switch	Mountable



* Refer to page 7-9-1 for further information on auto switches.

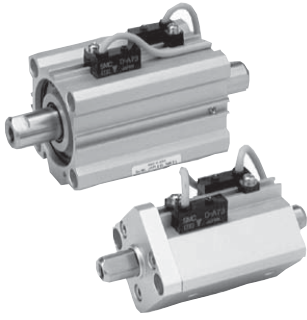

Minimum Stroke for Auto Switch Mounting

(mm)

Number of auto switches mounted	D-F7□V D-J79C D-M9□V	D-A7□ D-A80 D-A73C D-A80C D-A9□V	D-F7□WV D-F9□WV D-F7BAVL	D-A7□H D-A80H D-F7□ D-J79 D-M9□ D-F9□W	D-A79W	D-F7□W D-J79W D-F7BAL D-F79F D-F9BAL	D-A9□	D-P5DWL
1 pc.	5	5	10	15	15	20	10	30
2 pcs.	5	10	15	15	20	20	10	30

Weight

(g)

Bore size (mm)	Cylinder stroke (mm)											
	5	10	15	20	25	30	35	40	45	50	75	100
12	82	90	98	106	114	122	—	—	—	—	—	—
16	103	114	125	136	147	158	—	—	—	—	—	—
20	169	186	203	220	237	254	271	288	305	322	—	—
25	231	248	265	282	299	316	333	350	367	384	—	—
32	270	294	318	342	366	390	414	438	462	486	606	726
40	458	489	520	551	582	613	644	675	706	737	892	1047
50	—	680	725	770	815	860	905	950	995	1040	1265	1490
63	—	906	945	984	1023	1062	1101	1140	1179	1218	1413	1608

Additional Weight

(g)

Bore size (mm)	12	16	20	25	32	40	50	63
Both ends tapped style	—	—	—	—	—	6	6	19
Rod end male thread	Male thread	3	6	12	24	52	54	106
	Nut	2	4	8	16	34	34	64
Built-in One-touch fittings	—	—	—	—	12	12	21	21

Calculation: (Example) CDQ2KWA40-20DM

- Cylinder weight: CDQ2KWB40-20D..... 551 g
- Option weight: Both ends tapped style..... 6 g
- Rod end male thread..... 88 g

645 g

Add the weight of auto switches and mounting brackets.

Auto Switch Mounting Bracket Weight

Mounting bracket part no.	Applicable bore size (mm)	Weight (g)
BQ-1	12 to 25	1.5
BQ-2	32 to 63	1.5

* For the auto switch weight, refer to page 7-9-1.

Construction

ø12 to ø25

ø32

ø40 to ø63

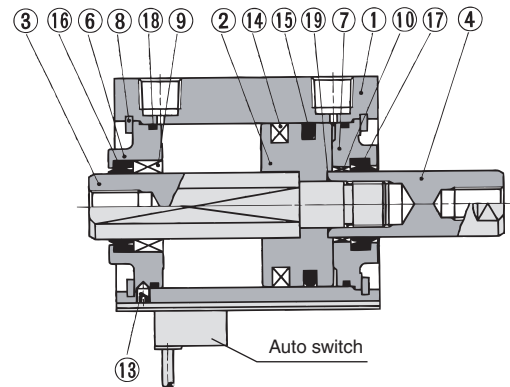
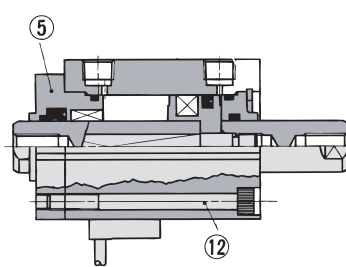
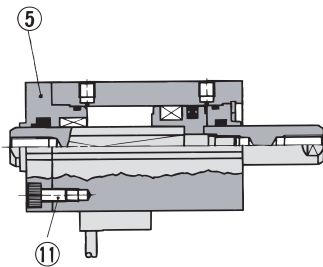

Component Parts

No.	Description	Material	Note
①	Cylinder tube	Aluminum alloy	Hard anodized
②	Piston	Aluminum alloy	Chromated
③	Piston rod A	Stainless steel	ø12 to ø25
		Carbon steel	ø32 to ø63, Hard chrome plated
④	Piston rod B	Stainless steel	ø12 to ø25
		Carbon steel	ø32 to ø63, Hard chrome plated
⑤	Rod cover	Brass	ø12, Nickel plated
		Aluminum alloy	ø16 to ø32, Anodized
⑥	Collar for non-rotating	Aluminum alloy	ø40 to ø63, Anodized
⑦	Collar	Aluminum alloy	ø12 to ø40, Anodized
		Aluminum alloy casted	ø50 to ø63, Chromated, painted
⑧	Snap ring	Carbon tool steel	Phosphate coated
⑨	Bushing for non-rotating	Oil-impregnated sintered alloy	ø16 to ø63
⑩	Bushing	Lead-bronze casted	ø50, ø63
⑪	Hexagon socket head cap screw	Alloy steel	ø12 to ø25, Nickel plated
⑫	Hexagon socket head cap screw	Alloy steel	ø32, Nickel plated
⑬	Hexagon socket head set screw	Alloy steel	ø40 to ø63, Nickel plated
⑭	Magnet	—	—

No.	Description	Material	Note
⑮	Piston seal	NBR	—
⑯	Rod seal for non-rotating	NBR	—
⑰	Rod seal	NBR	—
⑱	Gasket	NBR	—
⑲	Piston gasket	NBR	ø32 to ø63

Replacement Parts: Seal Kit

Bore size (mm)	Kit no.	Note
12	CQ2KWB12-PS	Set of nos. above ⑮, ⑯, ⑰, ⑱
16	CQ2KWB16-PS	
20	CQ2KWB20-PS	
25	CQ2KWB25-PS	
32	CQ2KWB32-PS	
40	CQ2KWB40-PS	
50	CQ2KWB50-PS	
63	CQ2KWB63-PS	

* Seal kit includes ⑮, ⑯, ⑰, ⑱. Order the seal kit, based on each bore size.

CUJ

CU

CQS

CQM

CQ2

RQ

MU

D-

-X

20-

Data

Series CDQ2KW

Mounting Bolt for CDQ2KWB with Auto Switch

Mounting method: Mounting bolt for through-hole mounting style of CDQ2KWB is available as an option.

Ordering: Add the word "Bolt" in front of the bolts to be used.

Example) Bolt M3 x 40ℓ 2 pcs.

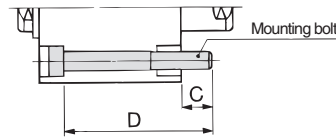

Mounting at non-rotating side

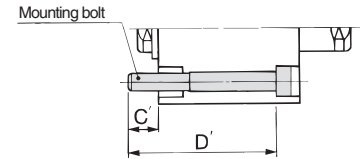

Model	C	D	Bolt	C'	D'	Bolt
CDQ2KWB12-5DC	6.1	40	M3 x 40ℓ	6.1	45	M3 x 45ℓ
-10DC		45	x 45ℓ		50	x 50ℓ
-15DC		50	x 50ℓ		55	x 55ℓ
-20DC		55	x 55ℓ		60	x 60ℓ
-25DC		60	x 60ℓ		65	x 65ℓ
-30DC		65	x 65ℓ		70	x 70ℓ
CDQ2KWB16-5D	7.5	45	M3 x 45ℓ	7.5	50	M3 x 50ℓ
-10D		50	x 50ℓ		55	x 55ℓ
-15D		55	x 55ℓ		60	x 60ℓ
-20D		60	x 60ℓ		65	x 65ℓ
-25D		65	x 65ℓ		70	x 70ℓ
-30D		70	x 70ℓ		75	x 75ℓ
CDQ2KWB20-5D	9	45	M5 x 45ℓ	11	55	M5 x 55ℓ
-10D		50	x 50ℓ		60	x 60ℓ
-15D		55	x 55ℓ		65	x 65ℓ
-20D		60	x 60ℓ		70	x 70ℓ
-25D		65	x 65ℓ		75	x 75ℓ
-30D		70	x 70ℓ		80	x 80ℓ
-35D		75	x 75ℓ		85	x 85ℓ
-40D		80	x 80ℓ		90	x 90ℓ
-45D		85	x 85ℓ		95	x 95ℓ
-50D		90	x 90ℓ		100	x 100ℓ
CDQ2KWB25-5D	8	45	M5 x 45ℓ	10	55	M5 x 55ℓ
-10D		50	x 50ℓ		60	x 60ℓ
-15D		55	x 55ℓ		65	x 65ℓ
-20D		60	x 60ℓ		70	x 70ℓ
-25D		65	x 65ℓ		75	x 75ℓ
-30D		70	x 70ℓ		80	x 80ℓ
-35D		75	x 75ℓ		85	x 85ℓ
-40D		80	x 80ℓ		90	x 90ℓ
-45D		85	x 85ℓ		95	x 95ℓ
-50D		90	x 90ℓ		100	x 100ℓ
CDQ2KWB32-5D	11	60	M5 x 60ℓ	7.5	55	M5 x 55ℓ
-10D		65	x 65ℓ		60	x 60ℓ
-15D		70	x 70ℓ		65	x 65ℓ
-20D		75	x 75ℓ		70	x 70ℓ
-25D		80	x 80ℓ		75	x 75ℓ
-30D		85	x 85ℓ		80	x 80ℓ
-35D		90	x 90ℓ		85	x 85ℓ
-40D		95	x 95ℓ		90	x 90ℓ
-45D		100	x 100ℓ		95	x 95ℓ
-50D		105	x 105ℓ		100	x 100ℓ
-75D		130	x 130ℓ		125	x 125ℓ
-100D	155	x 155ℓ	150	x 150ℓ		

Model	C	D	Bolt
CDQ2KWB40-5D	7	55	M5 x 55ℓ
-10D		60	x 60ℓ
-15D		65	x 65ℓ
-20D		70	x 70ℓ
-25D		75	x 75ℓ
-30D		80	x 80ℓ
-35D		85	x 85ℓ
-40D		90	x 90ℓ
-45D		95	x 95ℓ
-50D		100	x 100ℓ
CDQ2KWB50-10D	12.5	65	M6 x 65ℓ
-15D		70	x 70ℓ
-20D		75	x 75ℓ
-25D		80	x 80ℓ
-30D		85	x 85ℓ
-35D		90	x 90ℓ
-40D		95	x 95ℓ
-45D		100	x 100ℓ
-50D		105	x 105ℓ
-75D		130	x 130ℓ
CDQ2KWB63-10D	13.5	65	M8 x 65ℓ
-15D		70	x 70ℓ
-20D		75	x 75ℓ
-25D		80	x 80ℓ
-30D		85	x 85ℓ
-35D		90	x 90ℓ
-40D		95	x 95ℓ
-45D		100	x 100ℓ
-50D		105	x 105ℓ
-75D		130	x 130ℓ
-100D	155	x 155ℓ	

Auto Switch Mounting Bracket Part No.

Bore size (mm)	Mounting bracket part no.	Note	Applicable auto switch	
			Reed switch	Solid state switch
12, 16 20, 25	BQ-1	<ul style="list-style-type: none"> Switch mounting screw (M3 x 0.5 x 8ℓ) Square nut 	D-A7□/A80 D-A73C/A80C D-A7□H/A80H D-A79W	D-F7□/J79 D-F7□V D-J79C D-F7□W/J79W D-F7□WV D-F7BAL D-F79F D-F7NTL D-F7BAVL
32, 40 50, 63	BQ-2	<ul style="list-style-type: none"> Switch mounting screw (M3 x 0.5 x 10ℓ) Switch spacer Switch mounting nut 		
40 to 63	BQP1-050	<ul style="list-style-type: none"> Switch mounting bracket Switch mounting nut Hexagon socket head cap bolt (M3 x 0.5 x 14ℓ spring washer 2 pcs.) Round head Phillips screw (M3 x 0.5 x 16ℓ spring washer 2 pcs.) 	—	D-P5DWL

* Mounting screws set made of stainless steel
The set of stainless steel mounting screws (with nuts) described below is available and can be used depending on the operating environment. (Please order the auto switch spacer, since it is not included.)

BBA2: For D-A7/A8/F7/J7

"D-F7BAL/F7BAVL" switch is set on the cylinder with the stainless steel screws above when shipped.

When only a switch is shipped independently, "BBA2" screws are attached.

Compact Cylinder with Auto Switch: Non-rotating Rod Type Double Acting, Double Rod Series CDQ2KW

Proper Auto Switch Mounting Position (Detection at stroke end) and Its Mounting Height

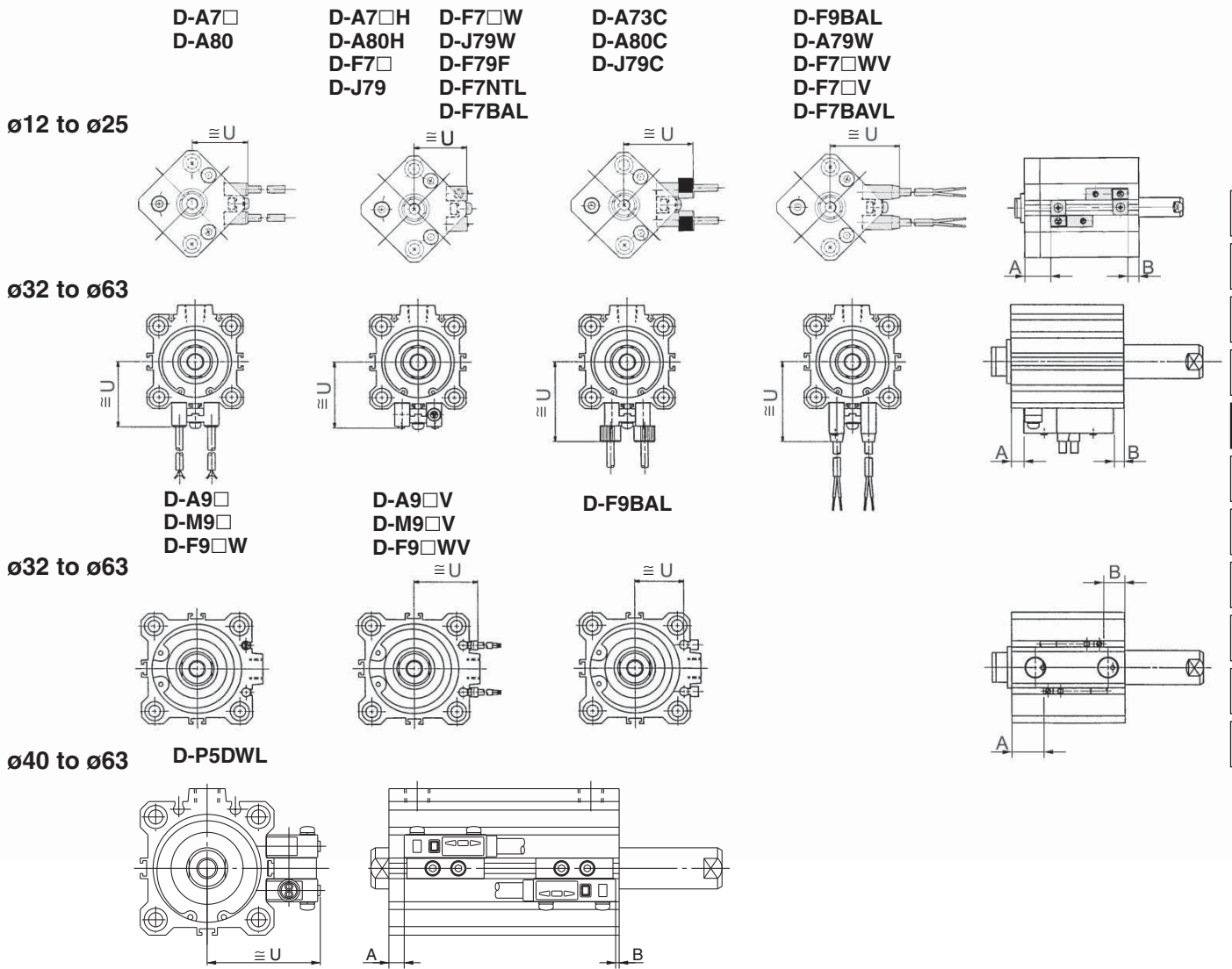

- CUJ
- CU
- CQS
- CQM
- CQ2**
- RQ
- MU
- D-
- X
- 20-
- Data

Proper Auto Switch Mounting Position

Bore size (mm)	D-A7□ D-A80		D-A7□H/A80H D-A73C/A80C D-F7□/J79/F79F D-F7□V/J79C D-F7BAL/F7□W D-J79W/F7□WV D-F7BAVL		D-A79W		D-A9□ D-A9□V		D-M9□ D-M9□V D-F9□W D-F9□WV		D-F9BAL		D-P5DWL	
	A	B	A	B	A	B	A	B	A	B	A	B	A	B
12	9.5	10	10	10.5	7	7.5	—	—	—	—	—	—	—	—
16	12.5	10.5	13	11	10	8	—	—	—	—	—	—	—	—
20	15.5	13	16	13.5	13	10.5	—	—	—	—	—	—	—	—
25	15.5	13	16	13.5	13	10.5	—	—	—	—	—	—	—	—
32	18	13.5	18.5	14	15.5	11	17	12.5	21	16.5	20	15.5	—	—
40	13	19	13.5	19.5	10.5	16.5	12	18	16	22	15	21	9	15
50	11	21.5	11.5	22	8.5	19	10	20.5	14	24.5	13	23.5	7	17.5
63	13.5	20.5	14	21	11	18	12.5	19.5	16.5	23.5	15.5	22.5	9.5	16.5

Auto Switch Mounting Height

Bore size (mm)	D-A7□ D-A80	D-A7□H D-A80H D-F7□ D-J79 D-F7□W D-F79W D-F79F D-F7BAL D-F7NTL	D-A73C D-A80C	D-F7□V D-F7□WV D-J79C	D-A79W	D-A9□V	D-M9□V D-F9□WV	D-F9BAL	D-P5DWL	
	U	U	U	U	U	U	U	U	U	
12	19.5	20.5	26.5	23	26	22	—	—	—	
16	22.5	23.5	29.5	26	29	25	—	—	—	
20	24.5	25.5	31.5	28	31	27	—	—	—	
25	27.5	28.5	34.5	31	34	30	—	—	—	
32	31.5	32.5	38.5	35	38	34	27	29	26.5	
40	35	36	42	38.5	41.5	37.5	30.5	32.5	30	44
50	41	42	48	44.5	47.5	43.5	36.5	38.5	36	50
63	47.5	48.5	54.5	51	54	50	40	42	39.5	56.5

Series CQ2KW

Dimensions: $\phi 12$ to $\phi 32$ /Without Auto Switch

Basic style (Through-hole): CQ2KWB

$\phi 12, \phi 16$

$\phi 20, \phi 25$

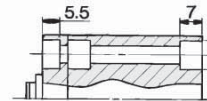
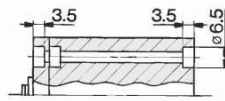

$\phi 12$ to $\phi 25$

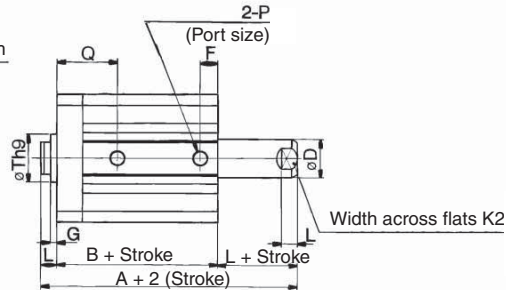
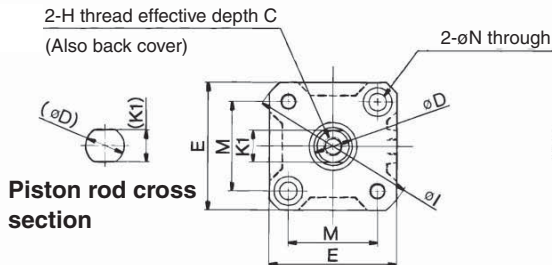

$\phi 32$

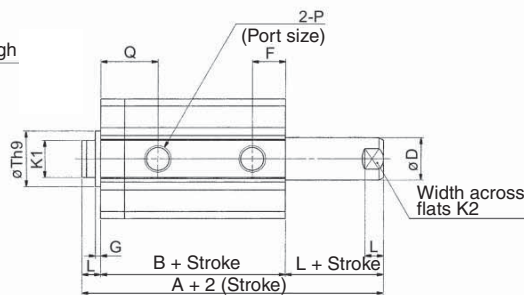
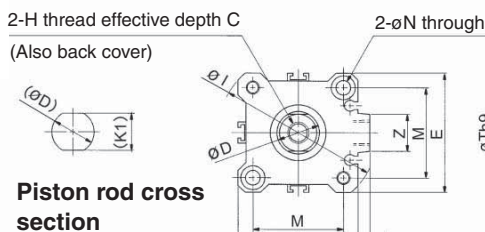
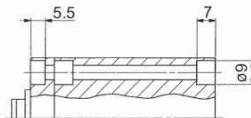

Rod End Male Thread

Bore size (mm)	Stroke range (mm)	A ₁	C ₁	H ₁
12	5 to 30	58.2	9	M5 x 0.8
16	5 to 30	62	10	M6 x 1.0
20	5 to 50	71	12	M8 x 1.25
25	5 to 50	82	15	M10 x 1.25
32	5 to 50	96.5	20.5	M14 x 1.5
	75, 100	106.5		

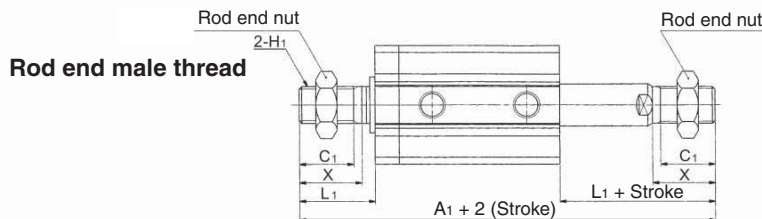

Bore size (mm)	L ₁	X
12	14	10.5
16	15.5	12
20	18.5	14
25	22.5	17.5
32	28.5	23.5

Built-in One-touch fittings: $\phi 32$

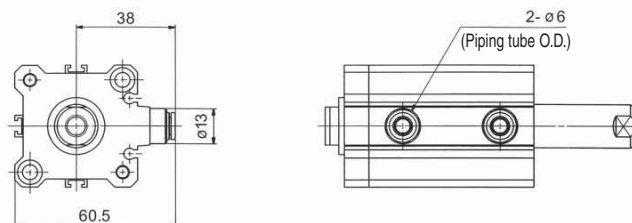

* In the case of w/ One-touch fitting, the 5 mm stroke with 32 bore is the same external dimensions as 10 mm stroke.

Basic Style

Bore size (mm)	Stroke range (mm)	A	B	C	D	E	F	G	H	I	J	K1	K2	L	M	N	P	Q	Th9	W	Z
12	5 to 30	37.2	30.2	6	6	25	10	1.5	M3 x 0.5	32	—	5.2	5	3.5	15.5	3.5	M5 x 0.8	15	15 ⁰ _{-0.043}	—	—
16	5 to 30	38	31	8	8	29	10	1.5	M4 x 0.7	38	—	6	6	3.5	20	3.5	M5 x 0.8	15	20 ⁰ _{-0.052}	—	—
20	5 to 50	43	34	7	10	36	9.5	2	M5 x 0.8	47	—	8	8	4.5	25.5	5.5	M5 x 0.8	17.5	13 ⁰ _{-0.043}	—	—
25	5 to 50	47	37	12	12	40	11	2	M6 x 1.0	52	—	10	10	5	28	5.5	M5 x 0.8	19	15 ⁰ _{-0.043}	—	—
32	5	53.5	39.5	13	16	45	12.5	2	M8 x 1.25	60	4.5	14	14	7	34	5.5	M5 x 0.8	21.5	21 ⁰ _{-0.052}	49.5	14
	10 to 50																				
	75, 100	63.5	49.5														RC 1/8				



* For details about the rod end nut and accessory brackets, refer to page 7-6-20.

Compact Cylinder with Auto Switch: Non-rotating Rod Type Double Acting, Double Rod Series CDQ2KW

Dimensions: $\phi 12$ to $\phi 32$ /With Auto Switch

Basic style (Through-hole): CDQ2KWB

$\phi 12, \phi 16$

$\phi 20, \phi 25$

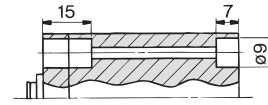
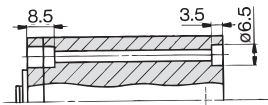

$\phi 12$ to $\phi 25$

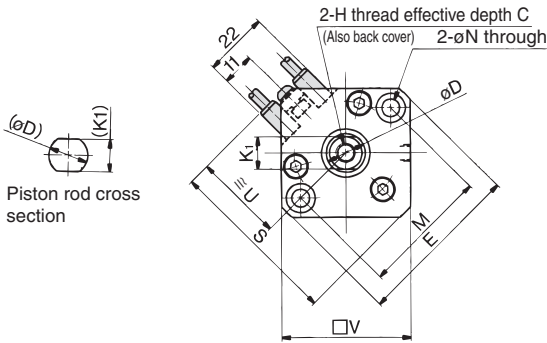

Piston rod cross section

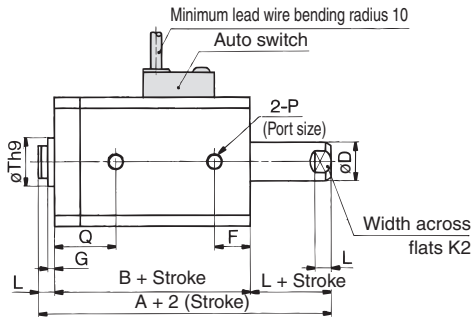

$\phi 32$

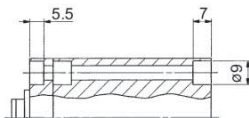

$\phi 32$

Piston rod cross section

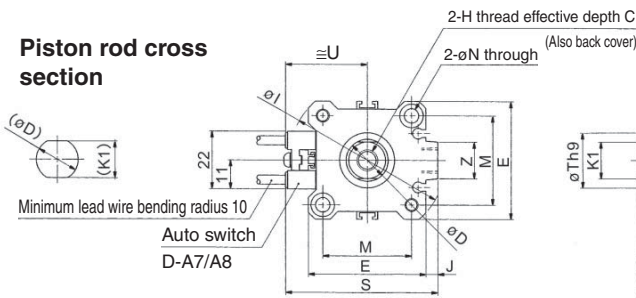

Minimum lead wire bending radius 10

Auto switch
D-A7/A8

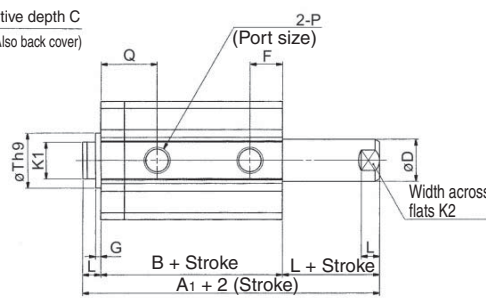

Rod end male thread

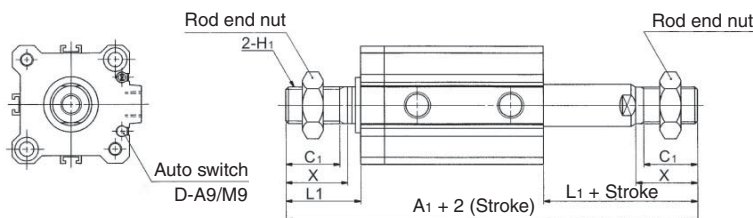

Rod End Male Thread

Bore size (mm)	A ₁	C ₁	H ₁
12	65.4	9	M5 x 0.8
16	72	10	M6 x 1.0
20	83	12	M8 x 1.25
25	92	15	M10 x 1.25
32	106.5	20.5	M14 x 1.5

Bore size (mm)	L ₁	X
12	14	10.5
16	15.5	12
20	18.5	14
25	22.5	17.5
32	28.5	23.5

Built-in One-touch fittings: $\phi 32$



Auto switch shown above is D-A73 type and D-A80 type.

For the auto switch mounting position and its mounting height, refer to page 7-6-83.

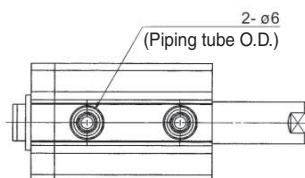
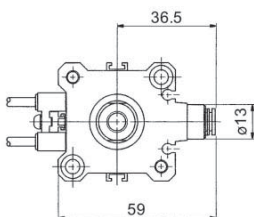

Basic Style

Bore size (mm)	Stroke range (mm)	A	B	C	D	E	F	G	H	I	J	K1	K2	L	M	N	P	Q	S	Th9	U	V	Z
12	5 to 30	44.4	37.4	6	6	32	10.5	1.5	M3 x 0.5	—	—	5.2	5	3.5	22	3.5	M5 x 0.8	15.5	35.5	15 ⁰ _{-0.043}	19.5	25	—
16	5 to 30	48	41	8	8	38	10	1.5	M4 x 0.7	—	—	6	6	3.5	28	3.5	M5 x 0.8	15	41.5	20 ⁰ _{-0.052}	22.5	29	—
20	5 to 50	55	46	7	10	47	10.5	2	M5 x 0.8	—	—	8	8	4.5	36	5.5	M5 x 0.8	18.5	48	13 ⁰ _{-0.043}	24.5	36	—
25	5 to 50	57	47	12	12	52	11	2	M6 x 1.0	—	—	10	10	5	40	5.5	M5 x 0.8	19	53.5	15 ⁰ _{-0.043}	27.5	40	—
32	5 to 50, 75, 100	63.5	49.5	13	16	45	12.5	2	M8 x 1.25	60	4.5	14	14	7	34	5.5	Rc 1/8	21.5	58.5	21 ⁰ _{-0.052}	31.5	—	14



* For details about the rod end nut and accessory brackets, refer to page 7-6-20.

Compact Cylinder: Non-rotating Rod Type Double Acting, Double Rod Series CQ2KW/CDQ2KW

Dimensions: $\phi 40$ to $\phi 63$

Foot style: CQ2KWL/CDQ2KWL

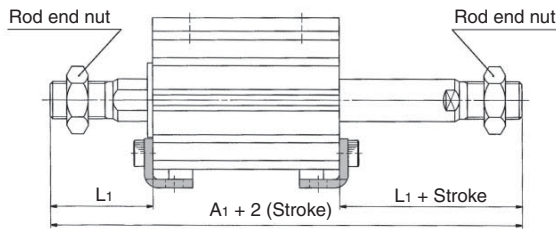
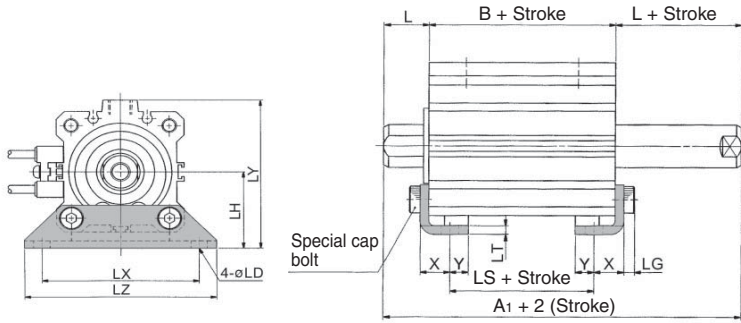

Rod End Male Thread

Bore size (mm)	Without auto switch	With auto switch	L ₁
	A ₁	A ₁	
40	117	127	38.5
50	127.5	137.5	43.5
63	129	139	43.5

Foot Style

Bore size (mm)	Stroke range (mm)	Without auto switch			With auto switch			L	LD	LG	LH	LT	LX	LY	LZ	X	Y
		A	B	LS	A	B	LS										
40	5 to 50	74	40	24	84	50	34	17	6.6	4	33	3.2	64	68	78	11.2	7
	75,100	84	50	34	84	50	34	17	6.6	4	33	3.2	64	68	78	11.2	7
50	10 to 50	76.5	40.5	17.5	86.5	50.5	27.5	18	9	5	39	3.2	79	78	95	14.7	8
	75,100	86.5	50.5	27.5	86.5	50.5	27.5	18	9	5	39	3.2	79	78	95	14.7	8
63	10 to 50	78	42	16	88	52	26	18	11	5	46	3.2	95	91.5	113	16.2	8
	75,100	88	52	26	88	52	26	18	11	5	46	3.2	95	91.5	113	16.2	8

Foot bracket material: Carbon steel

Flange style: CQ2KWF/CDQ2KWL

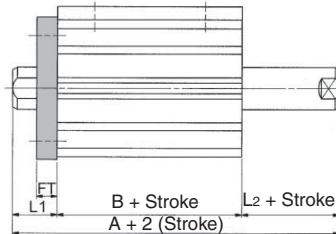
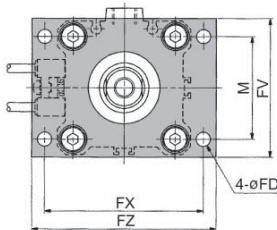

Rod End Male Thread

Bore size (mm)	Without auto switch	With auto switch	L ₃	L ₄
	A ₁	A ₁		
40	107	117	38.5	28.5
50	117.5	127.5	43.5	33.5
63	119	129	43.5	33.5

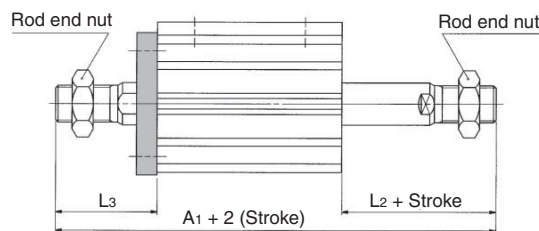

Auto switch shown above is D-A73 type and D-A80 type. For the auto switch mounting position and its mounting height, refer to page 7-6-83.

Flange Style

Bore size (mm)	Stroke range (mm)	Without auto switch		With auto switch		FD	FT	FV	FX	FZ	L ₁	L ₂	M
		A	B	A	B								
40	5 to 50	64	40	74	50	5.5	8	54	62	72	17	7	40
	75,100	74	50	74	50	5.5	8	54	62	72	17	7	40
50	10 to 50	66.5	40.5	76.5	50.5	6.6	9	67	76	89	18	8	50
	75,100	76.5	50.5	76.5	50.5	6.6	9	67	76	89	18	8	50
63	10 to 50	68	42	78	52	9	9	80	92	108	18	8	60
	75,100	78	52	78	52	9	9	80	92	108	18	8	60



* For details about the rod end nut and accessory brackets, refer to page 7-6-20.

Flange bracket material: Carbon steel

CUJ

CU

CQS

CQM

CQ2

RQ

MU

D-

-X

20-

Data



Compact Cylinder: Axial Piping Type Double Acting, Single Rod

Series CQP2

ø12, ø16, ø20, ø25, ø32, ø40, ø50, ø63, ø80, ø100

How to Order

Without auto switch
CQP2 B [] 50-30 D []

With auto switch
CDQP2 B [] 50-30 D []-J79W S

Built-in magnet (points to B)

Axial piping type (points to B)

Mounting style
B Through-hole

Type

Nil	Pneumatic
H	Air-hydro ^{Note)}

Note) Bore sizes available for air-hydro type are ø20 to ø100.

Bore size

12	12 mm
16	16 mm
20	20 mm
25	25 mm
32	32 mm
40	40 mm
50	50 mm
63	63 mm
80	80 mm
100	100 mm

Action
D Double acting

Cylinder stroke (mm)
Refer to "Standard Stroke" on page 7-6-89.

Auto switch

Nil	Without auto switch (Built-in magnet)
-----	---------------------------------------

* For the applicable auto switch model, refer to the table below.
* Auto switches are shipped together, (but not assembled). (Except D-P5DWL)

Number of auto switches

Nil	2 pcs.
S	1 pc.
n	"n" pcs.

Body option

Nil	Standard (Rod end female thread)
C	With rubber bumper ^{Note)}
M	Rod end male thread

* Combination of body option ("CM") is available.
Note) Air-hydro type with rubber bumper is not available.

Applicable Auto Switch/Refer to page 7-9-1 for further information on auto switches.

Type	Special function	Electrical entry	Indicator/light	Wiring (Output)	Load voltage		Auto switch model		Lead wire length (m) *				Pre-wire connector	Applicable load					
					DC	AC	Perpendicular	In-line	0.5 (Nil)	3 (L)	5 (Z)	None (N)							
Reed switch	—	Grommet	Yes	3-wire (NPN equivalent)	—	5 V	—	—	A76H	●	●	—	—	—	IC circuit	—			
				2-wire	—	—	200 V	A72	A72H	●	●	—	—	—	—	Relay, PLC			
		Connector	24 V	12 V	100 V	A73	A73H	●	●	●	—	—	—						
			—	—	—	—	A73C	—	●	●	●	●	—	—					
Solid state switch	—	Grommet	Yes	3-wire (NPN)	5 V, 12 V	—	—	F79	F79	●	●	○	—	○	IC circuit	Relay, PLC			
				3-wire (PNP)				F7PV	F7P	●	●	○	—	○					
		Connector		2-wire	12 V	—	F7BV	J79	●	●	○	—	○	—					
				2-wire	—	—	J79C	—	●	●	●	●	—	—					
		Grommet		3-wire (NPN)	5 V, 12 V	—	F7NWV	F79W	●	●	○	—	○	IC circuit					
				3-wire (PNP)	—	—	F7PW	—	●	●	○	—	○						
		Diagnostic indication (2-color indication)		Grommet	2-wire	24 V	12 V	—	—	F7BWV	J79W	●	●	○	—		○	—	
		Water resistant (2-color indication)			2-wire	—	—	—	—	F7BA	—	—	●	○	—		○	—	
		With diagnostic output (2-color indication)			4-wire (NPN)	5 V, 12 V	—	—	—	—	F7BAV	—	—	●	○		—	○	—
		Magnetic field resistant (2-color indication)			2-wire	—	—	—	—	—	F79F	—	●	●	○		—	○	IC circuit
—	—	—	—	—	—	—	—	P5DW	—	●	●	—	○	—	—				

* Lead wire length symbols: 0.5 m.....Nil (Example) A73C
 3 m.....L (Example) A73CL
 5 m.....Z (Example) A73CZ
 None.....N (Example) A73CN

* Solid state switches marked with "○" are produced upon receipt of order.

- D-P5DWL type is available from ø40 up to ø100 only.
- Since there are other applicable auto switches than listed, refer to page 7-6-23 for details.
- For details about auto switches with pre-wire connector, refer to page 7-9-36.

Compact Cylinder: Axial Piping Type Double Acting, Single Rod Series CQP2

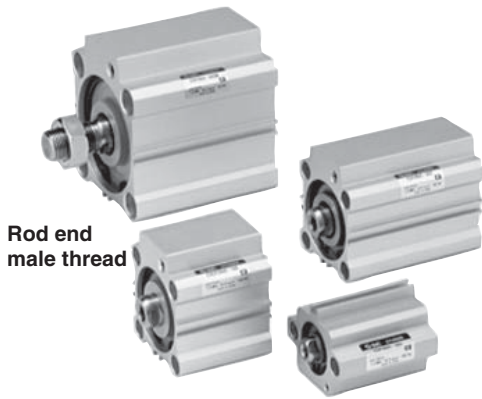

Rod end male thread

JIS Symbol
Double acting,
Single rod



⚠ Precautions

**Be sure to read before handling.
For Safety Instructions and
Actuator Precautions, refer to
pages 7-13-3 to 7-13-6.**

⚠ Caution

Snap Ring Installation/Removal

- For installation and removal, use an appropriate pair of pliers (tool for installing a type C snap ring).
- Even if a proper plier (tool for installing type C snap ring) is used, it is likely to inflict damage to a human body or peripheral equipment, as a snap ring may be flown out of the tip of a plier (tool for installing a type C snap ring). Be much careful with the popping of a snap ring. Besides, be certain that a snap ring is placed firmly into the groove of rod cover before supplying air at the time of installment.

Mounting/Removing

- Do not remove the hexagon socket set screw on the side of the rod.
 - Be aware that if the hexagon socket set screw is removed with compressed air supplied to the cylinder, an internal steel ball could fly out or the compressed air could be discharged, leading to injury to humans or damage to peripheral equipment.

Type

Bore size (mm)		12	16	20	25	32	40	50	63	80	100
Pneumatic	Mounting Through-hole (Standard)	●	●	●	●	●	●	●	●	●	●
	Built-in magnet	●	●	●	●	●	●	●	●	●	●
	Piping Screw-in type	M5 x 0.8	M5 x 0.8	M5 x 0.8	M5 x 0.8	Rc 1/8	Rc 1/8	Rc 1/4	Rc 1/4	Rc 3/8	Rc 3/8
	Rod end male thread	●	●	●	●	●	●	●	●	●	●
	Rubber bumper	●	●	●	●	●	●	●	●	●	●
Air-hydro	Mounting Through-hole (Standard)	—	—	●	●	●	●	●	●	●	●
	Built-in magnet	—	—	●	●	●	●	●	●	●	●
	Piping Screw-in type	—	—	M5 x 0.8	M5 x 0.8	Rc 1/8	Rc 1/8	Rc 1/4	Rc 1/4	Rc 3/8	Rc 3/8
	Rod end male thread	—	—	●	●	●	●	●	●	●	●

Standard Specifications

Type	Pneumatic (Non-lube)	Air-hydro
Fluid	Air	Turbine oil ⁽¹⁾
Proof pressure	1.5 MPa	
Maximum operating pressure	1.0 MPa	
Ambient and fluid temperature	Without auto switch: -10 to 70°C (No freezing) With auto switch: -10 to 60°C (No freezing)	5 to 60°C
Rubber bumper	None	—
Rod end thread	Female thread	
Rod end thread tolerance	JIS Class 2	
Stroke length tolerance	+1.0 0	
Mounting	Through-hole	
Piston speed	50 to 500 mm/s	5 to 50 mm/s

Standard Stroke

Pneumatic (Non-lube)

Bore (mm)	Standard stroke
12, 16	5, 10, 15, 20, 25, 30
20, 25	5, 10, 15, 20, 25, 30, 35, 40, 45, 50
32, 40	5, 10, 15, 20, 25, 30, 35, 40, 45, 50, 75, 100
50, 63 80, 100	10, 15, 20, 25, 30, 35, 40, 45, 50, 75, 100

Air-hydro

Bore (mm)	Standard stroke
20, 25	5, 10, 15, 20, 25, 30, 35, 40, 45, 50
32, 40	5, 10, 15, 20, 25, 30, 35, 40, 45, 50, 75, 100
50, 63 80, 100	10, 15, 20, 25, 30, 35, 40, 45, 50, 75, 100

Manufacture of Intermediate Stroke

Description	Spacer is installed in the standard stroke body.	
Part no.	Refer to "How to Order" for the standard model no. on page 7-6-88.	
Description	Dealing with the stroke by the 1 mm interval is available by installing spacer with standard stroke cylinder.	
Stroke range	Bore size	Stroke range
	12, 16	1 to 29
	20, 25	1 to 49
	32 to 100	1 to 99
Example	Part no.: CQP2B50-57D CQP2B50-75D with 18 mm width spacer inside. B dimension is 115.5 mm.	

- Air-hydro type is excluded.
- In the case of spacer type, intermediate stroke with damper for ø40 to ø100, it can be manufactured by 5 mm intervals in 5 mm and 55 to 95 mm.

CUJ

CU

CQS

CQM

CQ2

RQ

MU

D-

-X

20-

Data

Series CQP2



Made to Order Specifications (For details, refer to page 7-10-1.)

Symbol	Specifications
-XA□	Change of rod end shape
-XB6	Heat resistant cylinder (150°C)
-XB7	Cold resistant cylinder
-XB9	Low speed cylinder (10 to 50 mm/s)
-XB13	Low speed cylinder (5 to 50 mm/s)
-XC4	With heavy duty scraper
-XC6	Piston rod and rod end nut made of stainless steel
-XC18	NPT finish piping port
-XC35	With coil scraper
-XC36	With boss in rod side
-X271	Fluoro rubber for seals

Minimum Operating Pressure

(MPa)

Bore size (mm)	12	16	20	25	32	40	50	63	80	100
Pneumatic (Non-lube)	0.07	0.07	0.05	0.05	0.05	0.05	0.05	0.05	0.05	0.05
Air-hydro	—	—	0.18	0.18	0.18	0.10	0.10	0.10	0.10	0.10

Allowable Kinetic Energy

(J)

Bore size (mm)	12	16	20	25	32	40	50	63	80	100
Standard	0.022	0.038	0.055	0.09	0.15	0.26	0.46	0.77	1.36	2.27
With rubber bumper	0.043	0.075	0.11	0.18	0.29	0.52	0.91	1.54	2.71	4.54

Auto Switch Mounting Bracket Part No.

Bore size (mm)	Mounting bracket part no.	Note	Applicable auto switch	
			Reed switch	Solid state switch
12, 16 20, 25	BQ-1	<ul style="list-style-type: none"> Switch mounting screw (M3 x 0.5 x 8ϕ) Square nut 	D-A7□/A80 D-A73C/A80C D-A7□H/A80H D-A79W	D-F7□/J79 D-F7□V, D-J79C D-F7□W/J79W D-F7□WV, D-F7BAL D-F79F, D-F7NTL D-F7BAVL
32, 40 50, 63 80, 100	BQ-2	<ul style="list-style-type: none"> Switch mounting screw (M3 x 0.5 x 10ϕ) Switch spacer Switch mounting nut 		
40 to 100	BQP-050	<ul style="list-style-type: none"> Switch mounting bracket Switch mounting nut Hexagon socket head cap bolt (M3 x 0.5 x 14ϕ spring washer 2 pcs.) Round head Phillips screw (M3 x 0.5 x 16ϕ spring washer 2 pcs.) 	—	D-P5DWL



* Mounting screws set made of stainless steel

The set of stainless steel mounting screws (with nuts) described below is available and can be used depending on the operating environment.

(Since the spacer is not included, order it separately.)

BBA2: For D-A7/A8/F7/J7

"D-F7BAL/F7BAVL" switch is set on the cylinder with the stainless steel screws above when shipped.

When only a switch is shipped independently, "BBA2" screws are attached.

Compact Cylinder: Axial Piping Type Double Acting, Single Rod Series CQP2



Theoretical Output

(N)

Bore size (mm)	Operating direction	Operating pressure (MPa)		
		0.3	0.5	0.7
12	IN	25	42	59
	OUT	34	57	79
16	IN	45	75	106
	OUT	60	101	141
20	IN	71	118	165
	OUT	94	157	220
25	IN	113	189	264
	OUT	147	245	344
32	IN	181	302	422
	OUT	241	402	563
40	IN	317	528	739
	OUT	377	628	880
50	IN	495	825	1150
	OUT	589	982	1370
63	IN	841	1400	1960
	OUT	935	1560	2180
80	IN	1360	2270	3170
	OUT	1510	2510	3520
100	IN	2140	3570	5000
	OUT	2360	3930	5500

Weight

(g)

Bore size (mm)	Cylinder stroke (mm)											
	5	10	15	20	25	30	35	40	45	50	75	100
12	32	39	46	53	60	67	—	—	—	—	—	—
16	54	63	72	81	90	98	—	—	—	—	—	—
20	70	84	98	112	126	140	154	168	182	196	—	—
25	102	117	132	147	161	176	191	206	220	235	—	—
32	149	173	199	222	246	270	295	319	343	367	487	607
40	224	258	280	310	336	362	388	414	440	467	602	737
50	—	414	455	496	538	579	620	662	703	744	949	1154
63	—	584	632	679	727	774	822	870	917	965	1205	1445
80	—	1085	1163	1242	1320	1399	1477	1556	1634	1713	2108	2503
100	—	1894	1992	2091	2189	2287	2385	2483	2581	2679	3169	3659

Additional Weight

(g)

Bore size (mm)		12	16	20	25	32	40	50	63	80	100
Rod end male thread	Male thread	1.5	3	6	12	26	27	53	53	120	175
	Nut	1	2	4	8	17	17	32	32	49	116
With rubber bumper		0	0	-2	-3	-3	-7	-9	-18	-31	-56

Calculation: (Example) CQP2B32-20DCM

- Cylinder weight: CQP2B32-20D..... 222 g
- Option weight: Rod end male thread..... 43 g
- Rubber bumper..... -3 g
- 262 g

Mounting Bolt for CQP2

Mounting method: Mounting bolt for through-hole mounting style of CQP2B is available as an option.
Ordering: Add the word "Bolt" in front of the bolts to be used.
Example) Bolt M3 x 25ℓ 2 pcs.

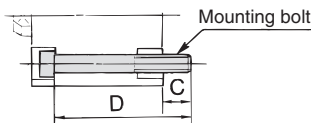

Model	C	D	Mounting bolt
CQP2B12-5D	6.5	25	M3 x 25ℓ
-10D		30	x 30ℓ
-15D		35	x 35ℓ
-20D		40	x 40ℓ
-25D		45	x 45ℓ
-30D		50	x 50ℓ
CQP2B16-5D	5	25	M3 x 25ℓ
-10D		30	x 30ℓ
-15D		35	x 35ℓ
-20D		40	x 40ℓ
-25D		45	x 45ℓ
-30D		50	x 50ℓ
CQP2B20-5D	7.5	25	M5 x 25ℓ
-10D		30	x 30ℓ
-15D		35	x 35ℓ
-20D		40	x 40ℓ
-25D		45	x 45ℓ
-30D		50	x 50ℓ
-35D		55	x 55ℓ
-40D		60	x 60ℓ
-45D		65	x 65ℓ
-50D		70	x 70ℓ
CQP2B25-5D	9.5	30	M5 x 30ℓ
-10D		35	x 35ℓ
-15D		40	x 40ℓ
-20D		45	x 45ℓ
-25D		50	x 50ℓ
-30D		55	x 55ℓ
-35D		60	x 60ℓ
-40D		65	x 65ℓ
-45D		70	x 70ℓ
-50D		75	x 75ℓ

Model	C	D	Mounting bolt
CQP2B32-5D	9	30	M5 x 30ℓ
-10D		35	x 35ℓ
-15D		40	x 40ℓ
-20D		45	x 45ℓ
-25D		50	x 50ℓ
-30D		55	x 55ℓ
-35D		60	x 60ℓ
-40D		65	x 65ℓ
-45D		70	x 70ℓ
-50D		75	x 75ℓ
CQP2B40-5D	7.5	35	M5 x 35ℓ
-10D		40	x 40ℓ
-15D		45	x 45ℓ
-20D		50	x 50ℓ
-25D		55	x 55ℓ
-30D		60	x 60ℓ
-35D		65	x 65ℓ
-40D		70	x 70ℓ
-45D		75	x 75ℓ
-50D		80	x 80ℓ
CQP2B50-10D	12.5	45	M6 x 45ℓ
-15D		50	x 50ℓ
-20D		55	x 55ℓ
-25D		60	x 60ℓ
-30D		65	x 65ℓ
-35D		70	x 70ℓ
-40D		75	x 75ℓ
-45D		80	x 80ℓ
-50D		85	x 85ℓ
-75D		120	x 120ℓ
-100D	145	x 145ℓ	

Model	C	D	Mounting bolt
CQP2B63-10D	14.5	50	M8 x 50ℓ
-15D		55	x 55ℓ
-20D		60	x 60ℓ
-25D		65	x 65ℓ
-30D		70	x 70ℓ
-35D		75	x 75ℓ
-40D		80	x 80ℓ
-45D		85	x 85ℓ
-50D		90	x 90ℓ
-75D		125	x 125ℓ
CQP2B80-10D	15	55	M10 x 55ℓ
-15D		60	x 60ℓ
-20D		65	x 65ℓ
-25D		70	x 70ℓ
-30D		75	x 75ℓ
-35D		80	x 80ℓ
-40D		85	x 85ℓ
-45D		90	x 90ℓ
-50D		95	x 95ℓ
-75D		130	x 130ℓ
CQP2B100-10D	15.5	65	M10 x 65ℓ
-15D		70	x 70ℓ
-20D		75	x 75ℓ
-25D		80	x 80ℓ
-30D		85	x 85ℓ
-35D		90	x 90ℓ
-40D		95	x 95ℓ
-45D		100	x 100ℓ
-50D		105	x 105ℓ
-75D		140	x 140ℓ
-100D	165	x 165ℓ	

CUJ

CU

CQS

CQM

CQ2

RQ

MU

D-

-X

20-

Data

Axial Piping: Double Acting, Single Rod Series **CDQP2** With Auto Switch



* Refer to page 7-9-1 for further information on auto switches.



Weight (g)

Bore size (mm)	Cylinder stroke (mm)											
	5	10	15	20	25	30	35	40	45	50	75	100
12	54	62	69	75	82	89	—	—	—	—	—	—
16	91	99	107	115	123	131	—	—	—	—	—	—
20	121	135	147	161	175	188	201	214	228	242	—	—
25	177	190	203	217	230	244	257	270	284	297	—	—
32	217	242	266	290	315	339	363	387	412	436	557	679
40	319	345	371	397	423	449	475	502	528	554	684	814
50	—	546	588	629	670	712	753	794	836	877	1084	1291
63	—	764	812	859	907	955	1002	1050	1098	1145	1384	1622
80	—	1377	1455	1534	1612	1691	1769	1848	1926	2005	2397	2790
100	—	2296	2394	2492	2590	2688	2786	2884	2982	3080	3570	4060

Calculation: (Example) CDQP2B32-20DCM
 • Cylinder weight: CDQP2B32-20D.....290 g
 • Option weight: Rod end male thread... 43 g
 Rubber bumper..... -3 g
 330 g

Add each weight of auto switches and mounting brackets.

Auto Switch Mounting Bracket Weight

Mounting bracket part no.	Applicable bore size	Weight (g)
BQ-1	12 to 250	1.5
BQ-2	32 to 100	1.5

For the auto switch weight, refer to page 7-9-1.

Additional Weight (g)

Bore size (mm)		12	16	20	25	32
Rod end	Male thread	1.5	3	6	12	26
male thread	Nut	1	2	4	8	17
With rubber bumper		0	-1	-2	-3	-3

Bore size (mm)		40	50	63	80	100
Rod end	Male thread	27	53	53	120	175
Male thread	Nut	17	32	32	49	116
With rubber bumper		-7	-9	-18	-31	-56

Minimum Stroke for Auto Switch Mounting (mm)

No. of auto switches mounted	D-F7□V D-J79C	D-A7□ D-A80 D-A73C D-A80C	D-F7□WV D-F7BAVL	D-A7□H D-A80H D-F7□ D-J79	D-A79W	D-F7□W D-J79W D-F7BAL D-F79F	D-P5DWL
1 pc.	5	5	10	15	15	20	30
2 pcs.	5	10	15	15	20	20	30

Note) For detailed specifications on auto switch, refer to page 7-9-1.

Construction

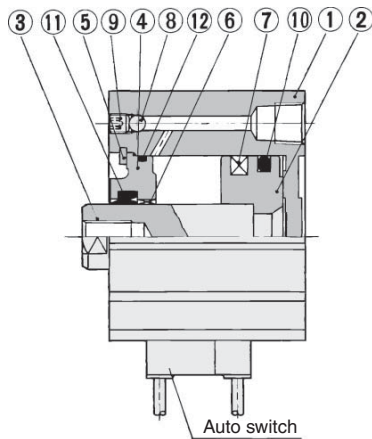

**A-A' section
(Rod side port)**

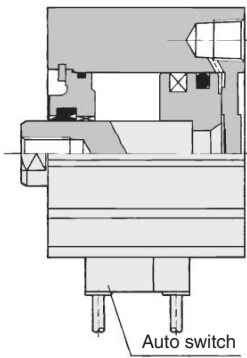

**B-B' section
(Head side port)**

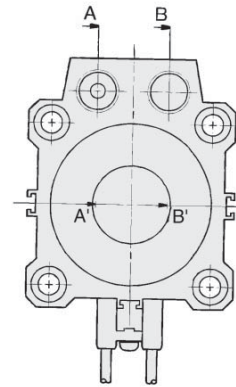

Component Parts

No.	Description	Material	Note
①	Cylinder tube	Aluminum alloy	Hard anodized
②	Piston	Aluminum alloy	Chromated
③	Piston rod	Stainless steel	ø12 to ø25
		Carbon steel	ø32 to ø100, Hard chrome plated
④	Collar	Aluminum alloy	ø12 to ø40, Anodized
		Aluminum alloy casted	ø50 to ø100, Chromated, painted
⑤	Snap ring	Carbon tool steel	Phosphate coated
⑥	Bushing	Lead-bronze casted	ø50 to ø100
⑦	Magnet	—	—
⑧	Steel balls	Bearing steel	—
⑨	Hexagon socket head set screw	Alloy steel	Zinc chromated
⑩	Piston seal	NBR	—
⑪	Rod seal	NBR	—
⑫	Gasket	NBR	—

Replacement Parts: Seal Kit

Bore size (mm)	Kit no.		Note
	Pneumatic (Non-lube)	Air-hydro	
12	CQ2B12-PS	—	Set of left nos. ⑩, ⑪, ⑫
16	CQ2B16-PS	—	
20	CQ2B20-PS	CQ2BH20-PS	
25	CQ2B25-PS	CQ2BH25-PS	
32	CQ2B32-PS	CQ2BH32-PS	
40	CQ2B40-PS	CQ2BH40-PS	
50	CQ2B50-PS	CQ2BH50-PS	
63	CQ2B63-PS	CQ2BH63-PS	
80	CQ2B80-PS	CQ2BH80-PS	
100	CQ2B100-PS	CQ2BH100-PS	

* Seal kit includes ⑩, ⑪, ⑫. Order the seal kit, based on each bore size.

Compact Cylinder with Auto Switch: Axial Piping Type Double Acting, Single Rod Series **CDQP2**

Construction

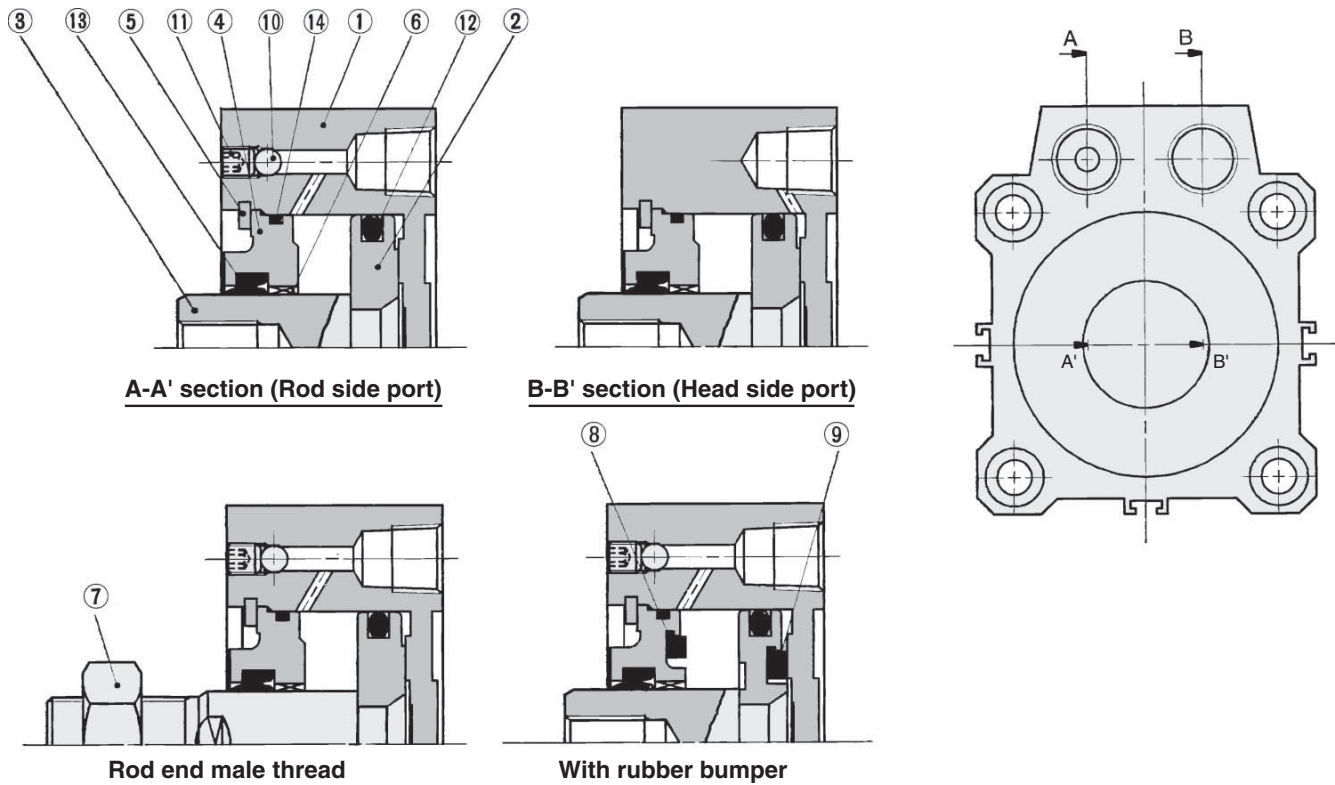

CUJ
CU
CQS
CQM
CQ2
RQ
MU
D-
-X
20-
Data

Component Parts

No.	Description	Material	Note
①	Cylinder tube	Aluminum alloy	Hard anodized
②	Piston*	Aluminum alloy	Chromated
③	Piston rod*	Stainless steel	ø12 to ø25
		Carbon steel	ø32 to ø100, Hard chrome plated
④	Collar	Aluminum alloy	ø12 to ø40, Anodized
		Aluminum alloy casting	ø50 to ø100, Chromated, Painted
⑤	Snap ring	Carbon tool steel	Phosphate coated
⑥	Bushing	Lead-bronze casting	ø50 to ø100
⑦	Rod end nut	Carbon steel	Nickel plated
⑧	Bumper A	Urethane	
⑨	Bumper B	Urethane	
⑩	Steel balls	Bearing steel	
⑪	Hexagon socket head set screw	Alloy steel	Zinc chromated
⑫	Piston seal	NBR	
⑬	Rod seal	NBR	
⑭	Gasket	NBR	

* On bore size ø12 with rubber bumper style, piston and piston rod are integrated (Stainless steel).

Replacement Parts: Seal Kit

Bore size (mm)	Kit no.		Note
	Pneumatic (Non-lube)	Air-hydro	
12	CQ2B12-PS	—	Set of left nos. ⑫, ⑬, ⑭
16	CQ2B16-PS	—	
20	CQ2B20-PS	CQ2BH20-PS	
25	CQ2B25-PS	CQ2BH25-PS	
32	CQ2B32-PS	CQ2BH32-PS	
40	CQ2B40-PS	CQ2BH40-PS	
50	CQ2B50-PS	CQ2BH50-PS	
63	CQ2B63-PS	CQ2BH63-PS	
80	CQ2B80-PS	CQ2BH80-PS	
100	CQ2B100-PS	CQ2BH100-PS	

* Seal kit includes ⑫, ⑬, ⑭. Order the seal kit, based on each bore size.

Copper-free (For CRT manufacturing process)

20 — CQP2B Bore size — Stroke D
 Copper-free — ø12, ø16, ø20, ø25, ø32, ø40, ø50, ø63, ø80, ø100

To prevent the influence of copper ions or halogen ions during CRT manufacturing processes, copper and fluorine materials are not used in the component parts.

Specifications

Action	Double acting, Single rod
Bore size (mm)	12, 16, 20, 25, 32, 40, 50, 63, 80, 100
Proof pressure	1.5 MPa
Maximum operating pressure	1.0 MPa
Rubber bumper	None
Piping	Screw-in piping
Piston speed	50 to 500 mm/s
Mounting	Through-hole
Auto switch	Mountable

Series CDQP2

Mounting Bolt for CDQP2 with Auto Switch

Mounting method: Mounting bolt for through-hole mounting style of CDQP2B is available as an option.

Ordering: Add the word "Bolt" in front of the bolts to be used.

Example) Bolt M3 x 35ℓ 2 pcs.

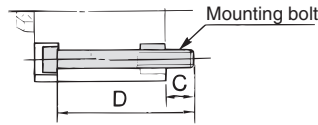

Model	C	D	Mounting bolt
CDQP2B12-5D	5.5	35	M3 x 35ℓ
-10D		40	x 40ℓ
-15D		45	x 45ℓ
-20D		50	x 50ℓ
-25D		55	x 55ℓ
-30D		60	x 60ℓ
CDQP2B16-5D	8	40	M3 x 40ℓ
-10D		45	x 45ℓ
-15D		50	x 50ℓ
-20D		55	x 55ℓ
-25D		60	x 60ℓ
-30D		65	x 65ℓ
CDQP2B20-5D	10.5	40	M5 x 40ℓ
-10D		45	x 45ℓ
-15D		50	x 50ℓ
-20D		55	x 55ℓ
-25D		60	x 60ℓ
-30D		65	x 65ℓ
-35D		70	x 70ℓ
-40D		75	x 75ℓ
-45D		80	x 80ℓ
-50D		85	x 85ℓ
CDQP2B25-5D	9.5	40	M5 x 40ℓ
-10D		45	x 45ℓ
-15D		50	x 50ℓ
-20D		55	x 55ℓ
-25D		60	x 60ℓ
-30D		65	x 65ℓ
-35D		70	x 70ℓ
-40D		75	x 75ℓ
-45D		80	x 80ℓ
-50D		85	x 85ℓ

Model	C	D	Mounting bolt
CDQP2B32-5D	9	40	M5 x 40ℓ
-10D		45	x 45ℓ
-15D		50	x 50ℓ
-20D		55	x 55ℓ
-25D		60	x 60ℓ
-30D		65	x 65ℓ
-35D		70	x 70ℓ
-40D		75	x 75ℓ
-45D		80	x 80ℓ
-50D		85	x 85ℓ
CDQP2B40-5D	7.5	45	M5 x 45ℓ
-10D		50	x 50ℓ
-15D		55	x 55ℓ
-20D		60	x 60ℓ
-25D		65	x 65ℓ
-30D		70	x 70ℓ
-35D		75	x 75ℓ
-40D		80	x 80ℓ
-45D		85	x 85ℓ
-50D		90	x 90ℓ
CDQP2B50-10D	12.5	55	M6 x 55ℓ
-15D		60	x 60ℓ
-20D		65	x 65ℓ
-25D		70	x 70ℓ
-30D		75	x 75ℓ
-35D		80	x 80ℓ
-40D		85	x 85ℓ
-45D		90	x 90ℓ
-50D		95	x 95ℓ
-75D		120	x 120ℓ
-100D	145	x 145ℓ	

Model	C	D	Mounting bolt
CDQP2B63-10D	14.5	60	M8 x 60ℓ
-15D		65	x 65ℓ
-20D		70	x 70ℓ
-25D		75	x 75ℓ
-30D		80	x 80ℓ
-35D		85	x 85ℓ
-40D		90	x 90ℓ
-45D		95	x 95ℓ
-50D		100	x 100ℓ
-75D		125	x 125ℓ
CDQP2B80-10D	15	65	M10 x 65ℓ
-15D		70	x 70ℓ
-20D		75	x 75ℓ
-25D		80	x 80ℓ
-30D		85	x 85ℓ
-35D		90	x 90ℓ
-40D		95	x 95ℓ
-45D		100	x 100ℓ
-50D		105	x 105ℓ
-75D		130	x 130ℓ
CDQP2B100-10D	15.5	75	M10 x 75ℓ
-15D		80	x 80ℓ
-20D		85	x 85ℓ
-25D		90	x 90ℓ
-30D		95	x 95ℓ
-35D		100	x 100ℓ
-40D		105	x 105ℓ
-45D		110	x 110ℓ
-50D		115	x 115ℓ
-75D		140	x 140ℓ
-100D	165	x 165ℓ	

Compact Cylinder with Auto Switch: Axial Piping Type Series **CDQP2**

Double Acting, Single Rod

Proper Auto Switch Mounting Position (Detection at stroke end) and Its Mounting Height

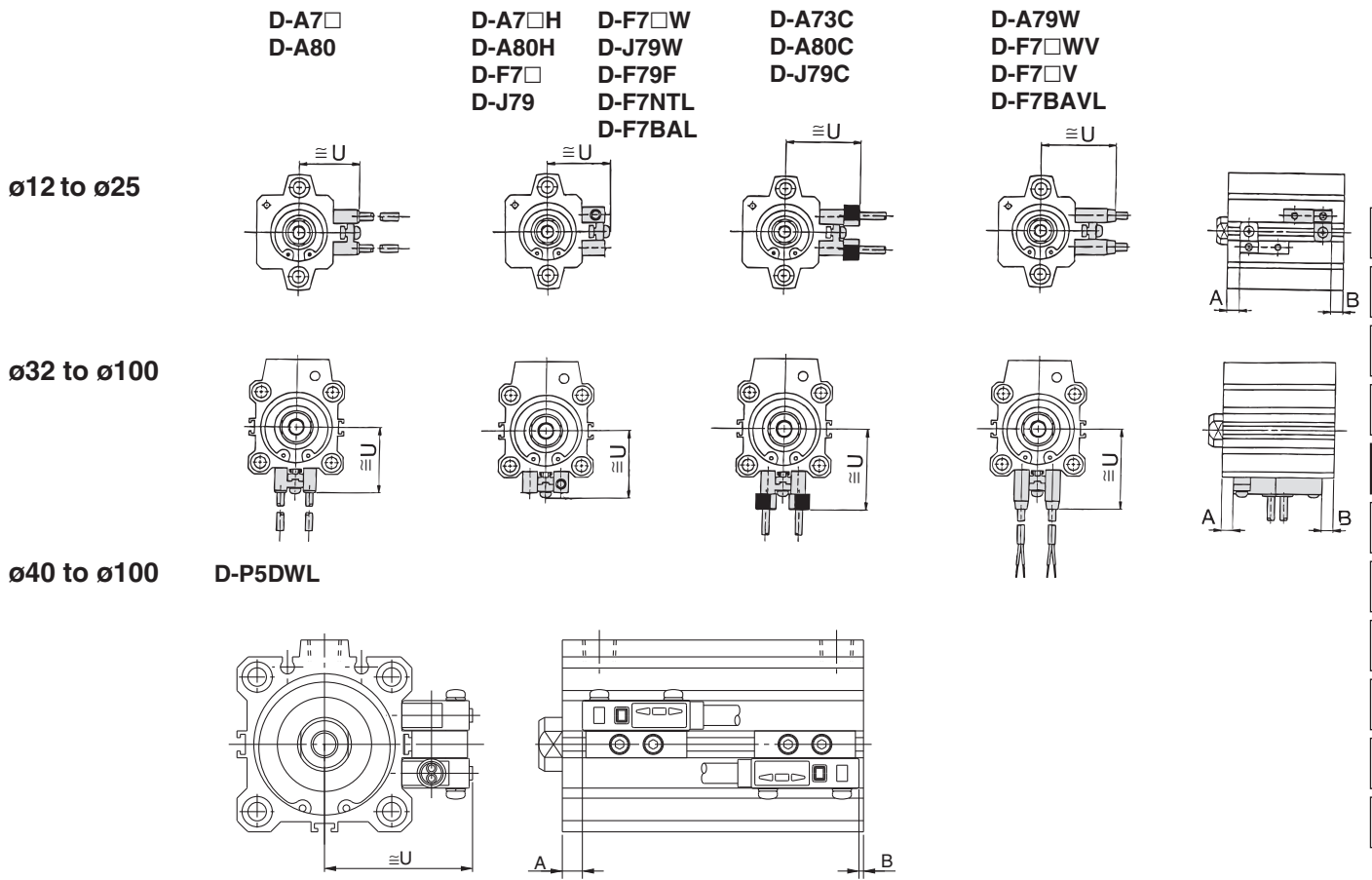

Proper Auto Switch Mounting Position

Bore size (mm)	D-A7□ D-A80		D-A7□H/A80H D-A73C/A80C D-F7□/J79 D-F7□V/J79C D-F7BAL/F7□W D-J79W/F7□WV D-F7BAVL/F79F		D-A79W		D-P5DWL	
	A	B	A	B	A	B	A	B
12	4.5	5.5	5	6	2	3	—	—
16	7.5	5	8	5.5	5	2.5	—	—
20	7.5	6.5	8	7	5	4	—	—
25	7.5	7	8	7.5	5	4.5	—	—
32	9	6	9.5	6.5	6.5	3.5	—	—
40	13	8.5	13.5	9	10.5	6	9	4.5
50	11	11.5	11.5	12	8.5	9	7	7.5
63	13.5	14.5	14	15	11	12	9.5	10.5
80	17.5	18	18	18.5	15	15.5	13.5	14
100	21	24	21.5	24.5	18.5	21.5	17	20

Auto Switch Mounting Height

(mm)

D-A7□ D-A80	D-A7□H, D-A80H D-F7□/J79/F7□W D-J79W, D-F7BAL D-F79F, D-F7NTL	D-A73C D-A80C	D-F7□V D-F7□WV D-F7BAVL	D-J79C	D-A79W	D-P5DWL
U	U	U	U	U	U	U
19.5	20.5	26.5	23	26	22	—
22.5	23.5	29.5	26	29	25	—
24.5	25.5	31.5	28	31	27	—
27.5	28.5	34.5	31	34	30	—
31.5	32.5	38.5	35	38	34	—
35	36	42	38.5	41.5	37.5	44
41	42	48	44.5	47.5	43.5	50
47.5	48.5	54.5	51	54	50	56.5
57.5	58.5	64.5	61	64	60	66.5
67.5	68.5	74.5	71	74	70	76.5

Series CDQP2

Dimensions: $\phi 12$ to $\phi 100$ /Without Auto Switch

$\phi 12$ to $\phi 25$

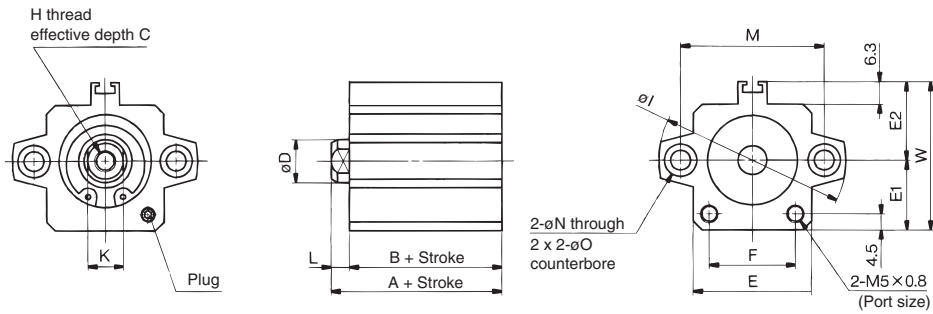

Rod end male thread

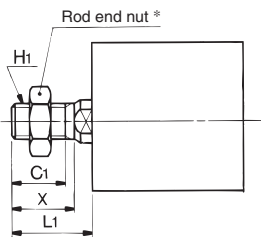

Rod End Male Thread

Bore size (mm)	C1	X	H1	L1
12	9	10.5	M5 x 0.8	14
16	10	12	M6 x 1.0	15.5
20	12	14	M8 x 1.25	18.5
25	15	17.5	M10 x 1.25	22.5

Basic Style

Bore size (mm)	Stroke range (mm)	A	B	C	D	E	E1	E2	F	H	I	K	L	M	N	O	W
12	5 to 30	20.5	17	6	6	23	13	14	14	M3 x 0.5	32	5	3.5	22	3.5	6.5 depth 3.5	27
16	5 to 30	22	18.5	8	8	26	15	17	17	M4 x 0.7	38	6	3.5	28	3.5	6.5 depth 3.5	32
20	5 to 50	24	19.5	7	10	30	17	19	21	M5 x 0.8	47	8	4.5	36	5.5	9 depth 7	36
25	5 to 50	27.5	22.5	12	12	33	19.5	22	24	M6 x 1.0	52	10	5	40	5.5	9 depth 7	41.5

$\phi 32$ to $\phi 100$

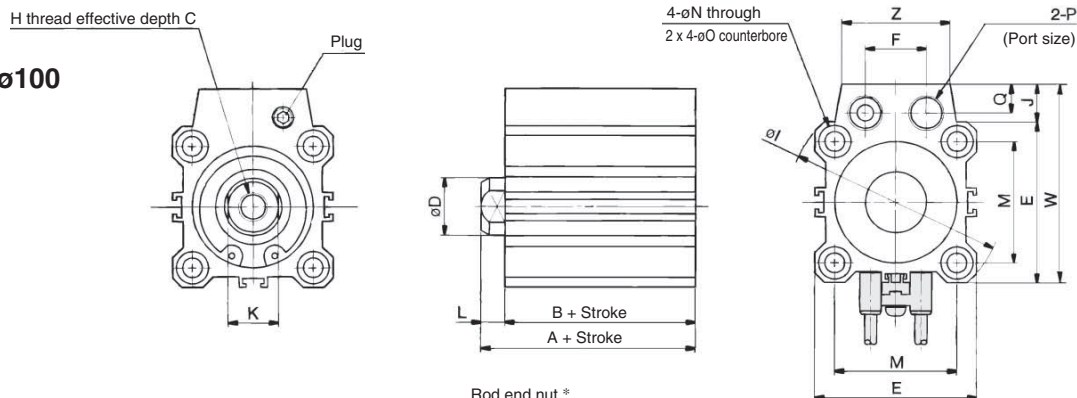

Rod end male thread

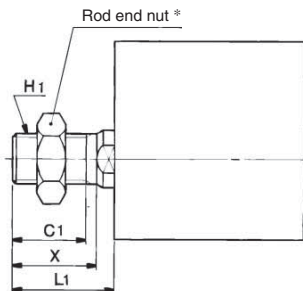

Rod End Male Thread

Bore size (mm)	C1	X	H1	L1
32	20.5	23.5	M14 x 1.5	28.5
40	20.5	23.5	M14 x 1.5	28.5
50	26	28.5	M18 x 1.5	33.5
63	26	28.5	M18 x 1.5	33.5
80	32.5	35.5	M22 x 1.5	43.5
100	32.5	35.5	M26 x 1.5	43.5

Basic Style

Bore size (mm)	Stroke range (mm)	A	B	C	D	E	F	H	I	J	K	L	M	N	O	P	Q	W	Z
32	5 to 50	30	23	13	16	45	17	M8 x 1.25	60	10.5	14	7	34	5.5	9 depth 7	Rc 1/8	8	55.5	30
	75,100	40	33																
40	5 to 50	36.5	29.5	13	16	52	17	M8 x 1.25	69	10	14	7	40	5.5	9 depth 7	Rc 1/8	8	62	30
	75,100	46.5	39.5																
50	10 to 50	38.5	30.5	15	20	64	22	M10 x 1.5	86	13	17	8	50	6.6	11 depth 8	Rc 1/4	10	77	39
	75,100	48.5	40.5																
63	10 to 50	44	36	15	20	77	22	M10 x 1.5	103	13	17	8	60	9	14 depth 10.5	Rc 1/4	10	90	39
	75,100	54	46																
80	10 to 50	53.5	43.5	21	25	98	26	M16 x 2.0	132	16	22	10	77	11	17.5 depth 13.5	Rc 3/8	12.5	114	48
	75,100	63.5	53.5																
100	10 to 50	65	53	27	30	117	26	M20 x 2.5	156	17.5	27	12	94	11	17.5 depth 13.5	Rc 3/8	12.5	134.5	48
	75,100	75	63																



Note) External dimensions with rubber bumper are the same as standard type, as shown above.

* For details about the rod end nut and accessory brackets, refer to page 7-6-20.

Compact Cylinder with Auto Switch: Axial Piping Type Double Acting, Single Rod Series **CDQP2**

Dimensions: $\phi 12$ to $\phi 100$ /With Auto Switch

$\phi 12$ to $\phi 25$

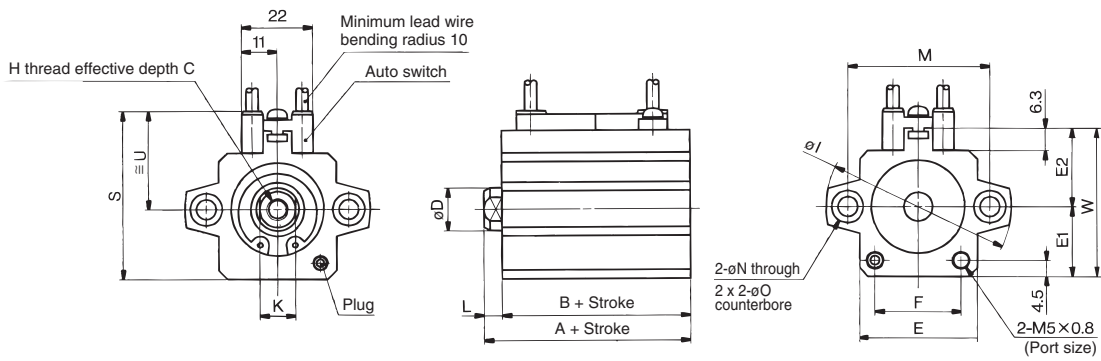

Rod end male thread



Auto switch shown above is D-A73 and D-A80. For the auto switch mounting position and its mounting height, refer to page 7-6-95.

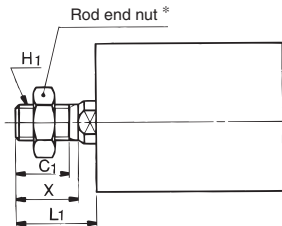

Rod End Male Thread

Bore size (mm)	C ₁	X	H ₁	L ₁
12	9	10.5	M5 x 0.8	14
16	10	12	M6 x 1.0	15.5
20	12	14	M8 x 1.25	18.5
25	15	17.5	M10 x 1.25	22.5

Basic Style

Bore size (mm)	Stroke range (mm)	A	B	C	D	E	E ₁	E ₂	F	H	I	K	L	M	N	O	S	U	W
12	5 to 30	31.5	28	6	6	23	13	14	14	M3 x 0.5	32	5	3.5	22	3.5	6.5 depth 3.5	32.5	19.5	27
16	5 to 30	34	30.5	8	8	26	15	17	17	M4 x 0.7	38	6	3.5	28	3.5	6.5 depth 3.5	37.5	22.5	32
20	5 to 50	36	31.5	7	10	30	17	19	21	M5 x 0.8	47	8	4.5	36	5.5	9 depth 7	41.5	24.5	36
25	5 to 50	37.5	32.5	12	12	33	19.5	22	24	M6 x 1.0	52	10	5	40	5.5	9 depth 7	47	27.5	41.5

Note) External dimensions with rubber bumper are the same as standard type, as shown above.

$\phi 32$ to $\phi 100$

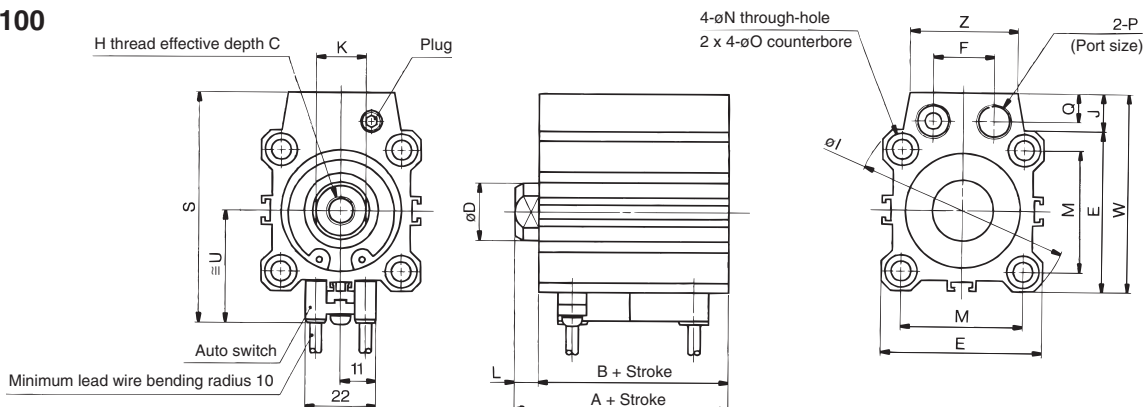

Rod end male thread



Auto switch shown above is D-A73 and D-A80. For the auto switch mounting position and its mounting height, refer to page 7-6-95.

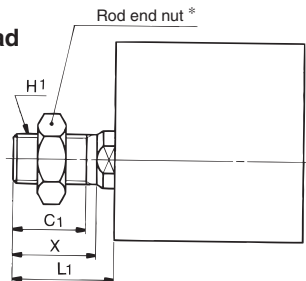

Rod End Male Thread

Bore size (mm)	C ₁	X	H ₁	L ₁
32	20.5	23.5	M14 x 1.5	28.5
40	20.5	23.5	M14 x 1.5	28.5
50	26	28.5	M18 x 1.5	33.5
63	26	28.5	M18 x 1.5	33.5
80	32.5	35.5	M22 x 1.5	43.5
100	32.5	35.5	M26 x 1.5	43.5

Basic Style

Bore size (mm)	Stroke range (mm)	A	B	C	D	E	F	H	I	J	K	L	M	N	O	P	Q	S	U	W	Z
32	5 to 100	40	33	13	16	45	17	M8 x 1.25	60	10.5	14	7	34	5.5	9 depth 7	Rc 1/8	8	64.5	31.5	55.5	30
40	5 to 100	46.5	39.5	13	16	52	17	M8 x 1.25	69	10	14	7	40	5.5	9 depth 7	Rc 1/8	8	71	35	62	30
50	10 to 100	48.5	40.5	15	20	64	22	M10 x 1.5	86	13	17	8	50	6.6	11 depth 8	Rc 1/4	10	86	41	77	39
63	10 to 100	54	46	15	20	77	22	M10 x 1.5	103	13	17	8	60	9	14 depth 10.5	Rc 1/4	10	99	47.5	90	39
80	10 to 100	63.5	53.5	21	25	98	26	M16 x 2.0	132	16	22	10	77	11	17.5 depth 13.5	Rc 3/8	12.5	122.5	57.5	114	48
100	10 to 100	75	63	27	30	117	26	M20 x 2.5	156	17.5	27	12	94	11	17.5 depth 13.5	Rc 3/8	12.5	143.5	67.5	134.5	48

Note) External dimensions with rubber bumper are the same as standard type, as shown above.

* For details about the rod end nut and accessory brackets, refer to page 7-6-20.



Compact Cylinder: Axial Piping Type

Single Acting, Single Rod, Spring Return/Extend

Series CQP2

ø12, ø16, ø20, ø25, ø32, ø40, ø50

How to Order

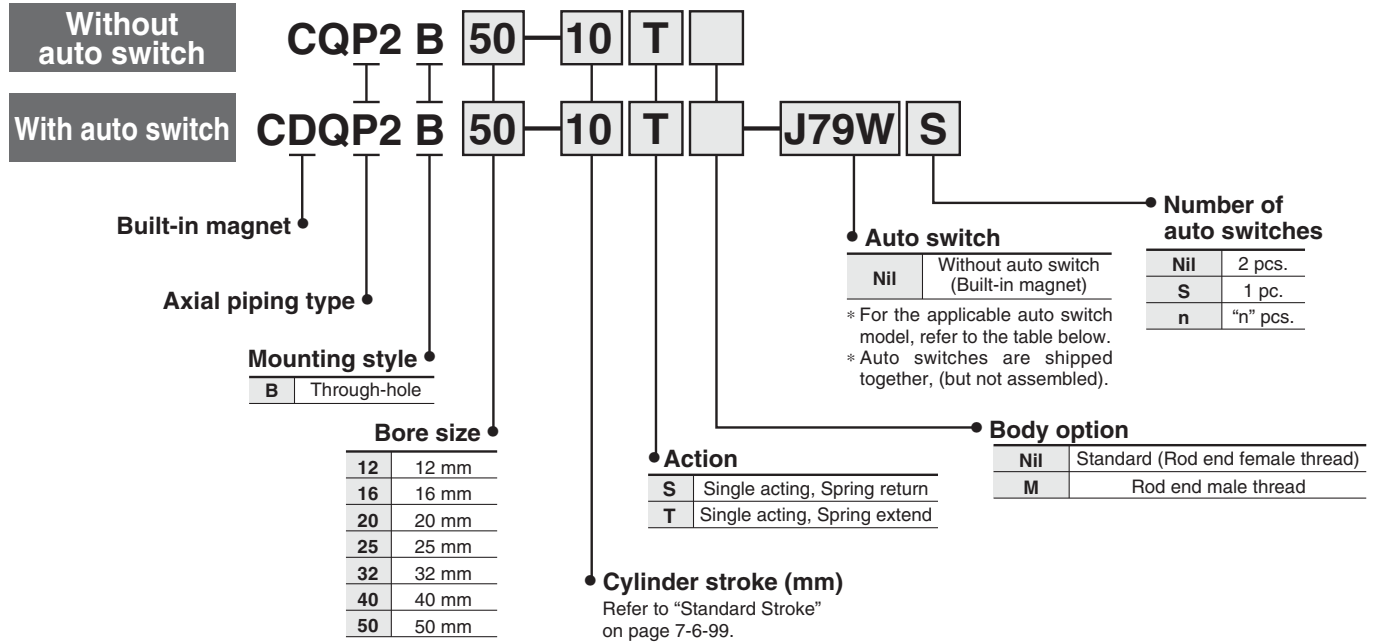

Applicable Auto Switch/Refer to page 7-9-1 for further information on auto switches.

Type	Special function	Electrical entry	Indicator light	Wiring (Output)	Load voltage		Auto switch model		Lead wire length (m) *				Pre-wire connector	Applicable load		
					DC	AC	Perpendicular	In-line	0.5 (Nil)	3 (L)	5 (Z)	None (N)		IC circuit	Relay, PLC	
Reed switch	—	Grommet	Yes	3-wire (NPN equivalent)	—	5 V	—	—	A76H	●	●	—	—	—	IC circuit	—
						200 V	A72	A72H	●	●	—	—	—	—	Relay, PLC	
	24 V	12 V		100 V	A73	A73H	●	●	●	—	—					
		—		—	—	A73C	—	●	●	●	●	—				
Diagnostic indication (2-color indication)	Grommet	—	—	A79W	—	●	●	—	—	—	—	—	—	—		
Solid state switch	—	Grommet	Yes	3-wire (NPN)	24 V	5 V, 12 V	—	F7NV	F79	●	●	○	—	○	IC circuit	Relay, PLC
				3-wire (PNP)				F7PV	F7P	●	●	○	—	○		
	2-wire	F7BV		J79	●	●	○	—	○	—						
		J79C		—	●	●	●	●	—	—						
	Diagnostic indication (2-color indication)	Grommet		3-wire (NPN)	5 V, 12 V	—	F7NWV	F79W	●	●	○	—	○	IC circuit		
				3-wire (PNP)			—	F7PW	●	●	○	—	○			
	Water resistant (2-color indication)	Grommet		2-wire	12 V	—	—	F7BWV	J79W	●	●	○	—	○	—	
							—	F7BA	—	●	○	—	○	—		
	With diagnostic output (2-color indication)	Grommet		4-wire (NPN)	5 V, 12 V	—	—	F7BAV	—	—	●	○	—	—	—	
							—	F79F	●	●	○	—	○	IC circuit		

* Lead wire length symbols: 0.5 m.....Nil
3 m.....L
5 m.....Z
None.....N

(Example) A73C
(Example) A73CL
(Example) A73CZ
(Example) A73CN

* Solid state switches marked with "○" are produced upon receipt of order.

- Since there are other applicable auto switches than listed, refer to page 7-6-23 for details.
- For details about auto switches with pre-wire connector, refer to page 7-9-36.

Compact Cylinder: Axial Piping Type Single Acting, Single Rod, Spring Return/Extend Series CQP2

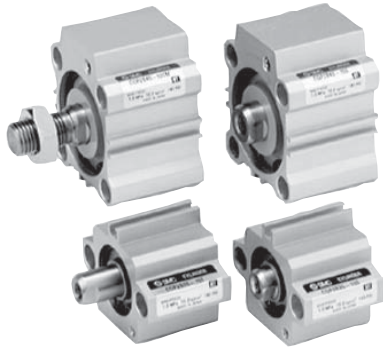

JIS Symbol

Single acting,
Spring return

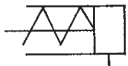

Single acting,
Spring extend



Made to Order Specifications (For details, refer to page 7-10-1.)

Symbol	Specifications
-XA□	Change of rod end shape
-XC6	Piston rod and rod end nut made of stainless steel
-XC36	With boss in rod side
-X271	Fluoro rubber for seals

⚠ Precautions

Be sure to read before handling.
For Safety Instructions and
Actuator Precautions, refer to
pages 7-13-3 to 7-13-6.

⚠ Caution

Snap Ring Installation/Removal

- For installation and removal, use an appropriate pair of pliers (tool for installing a type C snap ring).
- Even if a proper plier (tool for installing type C snap ring) is used, it is likely to inflict damage to a human body or peripheral equipment, as a snap ring may be flown out of the tip of a plier (tool for installing a type C snap ring). Be much careful with the popping of a snap ring. Besides, be certain that a snap ring is placed firmly into the groove of rod cover before supplying air at the time of installment.

Type

Bore size (mm)		12	16	20	25	32	40	50
Pneumatic	Mounting	Through-hole (Standard)	●	●	●	●	●	●
	Built-in magnet		●	●	●	●	●	●
	Piping	Screw-in type	M5 x 0.8	M5 x 0.8	M5 x 0.8	M5 x 0.8	Rc 1/8	Rc 1/8
	Rod end male thread		●	●	●	●	●	●

Standard Specifications

Type	Pneumatic (Non-lube)
Fluid	Air
Proof pressure	1.5 MPa
Maximum operating pressure	1.0 MPa
Ambient and fluid temperature	Without auto switch: -10 to 70°C (No freezing) With auto switch: -10 to 60°C (No freezing)
Rubber bumper	None
Rod end thread	Female thread
Rod end thread tolerance	JIS Class 2
Stroke length tolerance	$\begin{matrix} +1.0 \\ 0 \end{matrix}$
Mounting	Through-hole
Piston speed	50 to 500 mm/s

Minimum Operating Pressure

(MPa)

Bore size (mm)	12	16	20	25	32	40	50
Single acting (Spring return/extend)	0.25	0.25	0.18	0.18	0.17	0.15	0.13

Standard Stroke

Bore size (mm)	Standard stroke
12	5, 10
16	
20	
25	
32	
40	10, 20
50	

Manufacture of Intermediate Stroke (Single acting, Spring retract type is excluded.)

Description	Spacer is installed in the standard stroke body.	
Part no.	Refer to "How to Order" for the standard model no. on page 7-6-98.	
Description	Dealing with the stroke by the 1 mm interval is available by installing spacer with standard stroke cylinder.	
Stroke range	Bore size	Stroke range
	12 to 40	1 to 9
	50	1 to 19
Example	Part no.: CQP2B20-3T CQP2B20-5T with 2 mm width spacer inside. B dimension is 24.5 mm.	

CUJ

CU

CQS

CQM

CQ2

RQ

MU

D-

-X

20-

Data

Series CQP2

Theoretical Output

(N)

Action	Bore size (mm)	Operating pressure (MPa)		
		0.3	0.5	0.7
Spring return	12	21	44	66
	16	45	86	126
	20	79	142	205
	25	126	224	323
	32	211	372	533
	40	338	589	841
	50	535	928	1316
Spring extend	12	14	31	48
	16	24	54	85
	20	71	118	165
	25	113	189	264
	32	181	302	422
	40	317	528	739
	50	495	825	1150

For spring force, refer to page 7-12-3.

Mounting Bolt for CQP2

Mounting method: Mounting bolt for through-hole mounting style of CQP2B is available as an option.

Ordering: Add the word "Bolt" in front of the bolts to be used.

Example) Bolt M3 x 25ℓ 4 pcs.

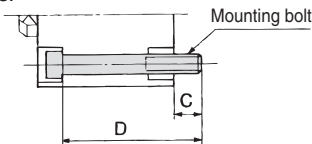

Spring Return

Model	C	D	Mounting bolt
CQP2B12-5S	6.5	25	M3 x 25ℓ
-10S		30	x 30ℓ
CQP2B16-5S	5	25	M3 x 25ℓ
-10S		30	x 30ℓ
CQP2B20-5S	7.5	25	M5 x 25ℓ
-10S		30	x 30ℓ
CQP2B25-5S	9.5	30	M5 x 30ℓ
-10S		35	x 35ℓ
CQP2B32-5S	9	30	M5 x 30ℓ
-10S		35	x 35ℓ
CQP2B40-5S	7.5	35	M5 x 35ℓ
-10S		40	x 40ℓ
CQP2B50-10S	12.5	45	M6 x 45ℓ
-20S		55	x 55ℓ

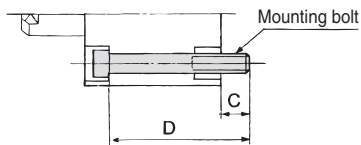

Spring Extend

Model	C	D	Mounting bolt
CQP2B12-5T	6.5	25	M3 x 25ℓ
-10T		30	x 30ℓ
CQP2B16-5T	5	25	M3 x 25ℓ
-10T		30	x 30ℓ
CQP2B20-5T	7.5	25	M5 x 25ℓ
-10T		30	x 30ℓ
CQP2B25-5T	9.5	30	M5 x 30ℓ
-10T		35	x 35ℓ
CQP2B32-5T	9	30	M5 x 30ℓ
-10T		35	x 35ℓ
CQP2B40-5T	7.5	35	M5 x 35ℓ
-10T		40	x 40ℓ
CQP2B50-10T	12.5	45	M6 x 45ℓ
-20T		55	x 55ℓ

Weight

(g)

Action	Bore size (mm)	Cylinder stroke (mm)			
		5	10	15	20
Spring return	12	33	40	—	—
	16	55	64	—	—
	20	68	83	—	—
	25	103	118	—	—
	32	149	173	—	—
	40	236	262	—	—
	50	—	426	—	691
Spring extend	12	33	40	—	—
	16	55	64	—	—
	20	73	87	—	—
	25	109	124	—	—
	32	160	180	—	—
	40	262	284	—	—
	50	—	468	—	540

Additional Weight

(g)

Bore size (mm)		12	16	20	25	32	40	50
Rod end male thread	Male thread	1.5	3	6	12	26	27	53
	Nut	1	2	4	8	17	17	32

Calculation: (Example) CQP2B32-10SM

- Cylinder weight: CQP2B32-10S..... 173 g
- Option weight: Rod end male thread..... 43 g
- 216 g

Auto Switch Mounting Bracket Part No.

Bore size (mm)	Mounting bracket part no.	Note	Applicable auto switch	
			Reed switch	Solid state switch
12, 16 20, 25	BQ-1	<ul style="list-style-type: none"> • Switch mounting screw (M3 x 0.5 x 8 ℓ) • Square nut 	D-A7□/A80 D-A73C/A80C	D-F7□/J79 D-F7□V D-J79C
				D-F7□W/J79W D-F7□WV
32, 40 50	BQ-2	<ul style="list-style-type: none"> • Switch mounting screw (M3 x 0.5 x 10 ℓ) • Switch spacer • Switch mounting nut 	D-A7□H/A80H D-A79W	D-F7BAL/F7BAVL D-F79F D-F7NTL



* Mounting screws set made of stainless steel

The set of stainless steel mounting screws (with nuts) described below is available and can be used depending on the operating environment. (Please order the auto switch spacer, since it is not included.)

BBA2: For D-A7/A8/F7/J7

"D-F7BAL/F7BAVL" switch is set on the cylinder with the stainless steel screws above when shipped.

When only a switch is shipped independently, "BBA2" screws are attached.

Compact Cylinder: Axial Piping Type Single Acting, Single Rod, Spring Return/Extend Series CQP2

Construction

Spring return

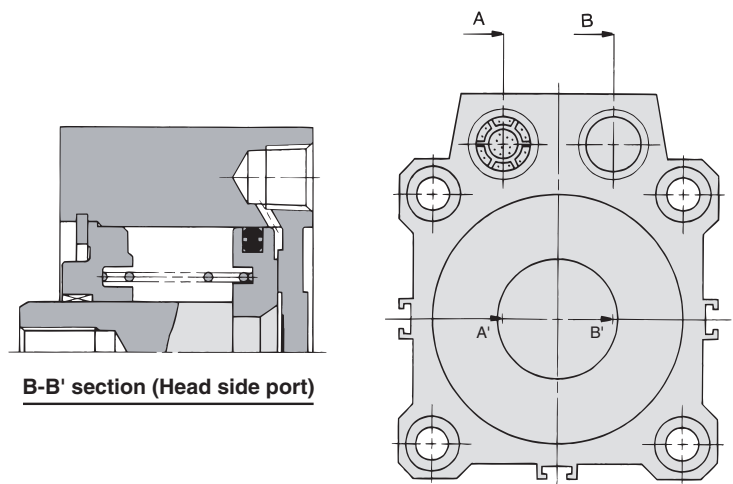
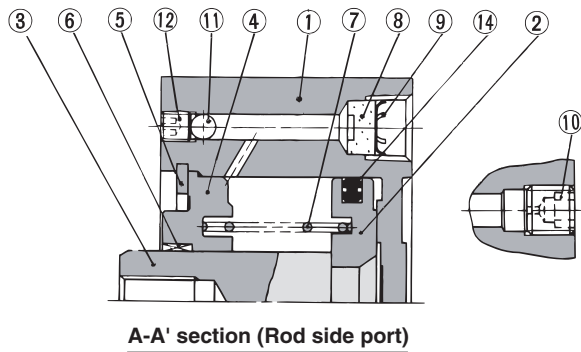

Spring extend

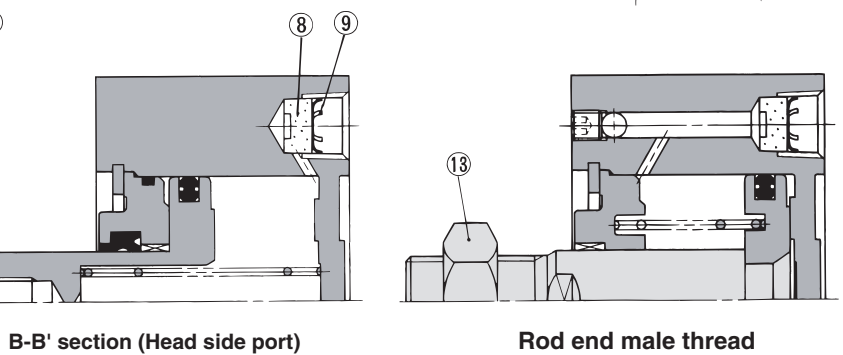
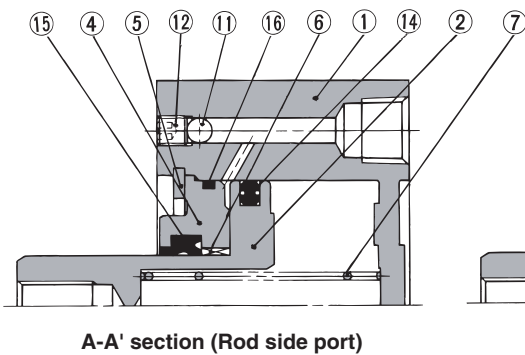

- CUJ
- CU
- CQS
- CQM
- CQ2**
- RQ
- MU
- D-
- X
- 20-
- Data

Component Parts

No.	Description	Material	Note
①	Cylinder tube	Aluminum alloy	Hard anodized
②*	Piston	Aluminum alloy	Chromated
③	Piston rod	Stainless steel	ø12 to ø25
		Carbon steel	ø32 to ø50, Hard chrome plated
④	Collar	Aluminum alloy	ø12 to ø40, Anodized
		Aluminum alloy casted	ø50, Chromate, Painted
⑤	Snap ring	Carbon tool steel	Phosphate coated
⑥	Bushing	Lead-bronze casted	ø50, Spring return
		Lead-bronze casted	ø50, Spring extend
⑦	Return spring	Piano wire	Zinc chromated
⑧	Bronze element	Sintered metallic BC	Port size Rc 1/8, 1/4
⑨	Snap ring	Carbon tool steel	
⑩	Plug with fixed orifice	Alloy steel	Port size M5 x 0.8
⑪	Steel balls	Bearing steel	
⑫	Hexagon socket head set screw	Alloy steel	Zinc chromated
⑬	Rod end nut	Carbon steel	Nickel plated

* On spring extend (Type T), piston and piston rod are integrated (stainless steel).

Replacement Parts

No.	Description	Material	Note
⑭	Piston seal	NBR	
⑮	Rod seal	NBR	
⑯	Gasket	NBR	

Replacement Parts: Seal Kit

Bore size (mm)	Single acting/Spring return	Single acting/Spring extend
12	CQ2B12-S-PS	CQ2B12-T-PS
16	CQ2B16-S-PS	CQ2B16-T-PS
20	CQ2B20-S-PS	CQ2B20-T-PS
25	CQ2B25-S-PS	CQ2B25-T-PS
32	CQ2B32-S-PS	CQ2B32-T-PS
40	CQ2B40-S-PS	CQ2B40-T-PS
50	CQ2B50-S-PS	CQ2B50-T-PS
Note	A set includes ⑭.	Kits include items ⑭, ⑮ and ⑯ from the table above
How to order	* Seal kit includes ⑭. Order the seal kit, based on each bore size.	* Seal kit includes ⑭, ⑮, ⑯. Order the seal kit, based on each bore size.

Copper-free (For CRT manufacturing process)

20 — CQP2B Bore size — Stroke $\frac{S}{T}$ (M)
 Copper-free — ø12, ø16, ø20, ø25, ø32, ø40, ø50

To prevent the influence of copper ions or halogen ions during CRT manufacturing processes, copper and fluorine materials are not used in the component parts.

Specifications

Action	Single acting, Single rod
Bore size (mm)	12, 16, 20, 25, 32, 40, 50
Proof pressure	1.5 MPa
Maximum operating pressure	1.0 MPa
Rubber bumper	None
Piping	Screw-in piping
Piston speed	50 to 500 mm/s
Mounting	Through-hole
Auto switch	Mountable



* Refer to page 7-9-1 for further information on auto switches.

Axial Piping: Single Acting, Single Rod Series **CDQP2** With Auto Switch

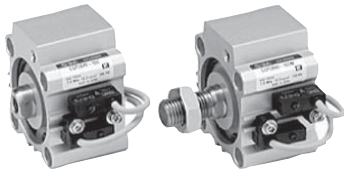

Minimum Stroke for Auto Switch Mounting

(mm)

No. of auto switches mounted	D-F7□V D-J79C	D-A7□ D-A80 D-A73C D-A80C	D-F7□WV D-F7BAVL	D-A7□H D-A80H D-F7□ D-J79	D-A79W	D-F7□W D-J79W D-F7BAL D-F79F
1 pc.	5	5	10	15	15	20
2 pcs.	5	10	15	15	20	20

Note) Refer to page 7-6-92 in series CQ2, double acting for detailed specifications on auto switch.

Weight

(g)

Action	Bore size (mm)	Cylinder stroke (mm)			
		5	10	15	20
Spring return	12	55	63	—	—
	16	92	100	—	—
	20	121	135	—	—
	25	178	191	—	—
	32	217	242	—	—
	40	323	349	—	—
Spring extend	50	—	558	—	641
	12	61	69	—	—
	16	92	100	—	—
	20	126	140	—	—
	25	184	197	—	—
	32	228	253	—	—
40	349	375	—	—	
50	—	600	—	683	

Additional Weight

(g)

Bore size (mm)		12	16	20	25	32	40	50
Rod end male thread	Male thread	1.5	3	6	12	26	27	53
	Nut	1	2	4	8	17	17	32

Calculation: (Example) CDQP2B32-10SM

- Cylinder weight: CDQP2B32-10S..... 242 g
 - Option weight: Rod end male thread..... 43 g
- 285 g

Add each weight of auto switches and mounting brackets when auto switches are mounted.

Auto Switch Mounting Bracket Weight

Mounting bracket part no.	Applicable bore size (mm)	Weight (g)
BQ-1	12 to 25	1.5
BQ-2	32 to 50	1.5

* For the auto switch weight, refer to page 7-9-1.

Construction

Spring return

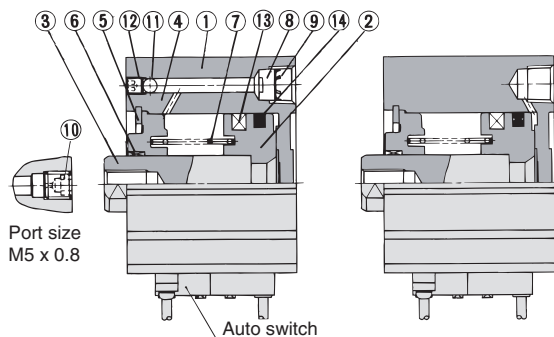

A-A' section
(Rod side port)

B-B' section
(Head side port)

Spring extend

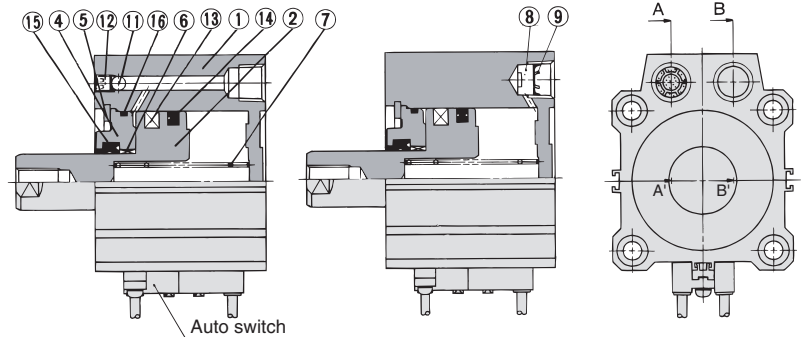

A-A' section
(Rod side port)

B-B' section
(Head side port)

Component Parts

No.	Description	Material	Note
①	Cylinder tube	Aluminum alloy	Hard anodized
②	Piston *	Aluminum alloy	Chromated
③	Piston rod *	Stainless steel	ø12 to ø25
		Carbon steel	ø32 to ø50, Hard chrome plated
④	Collar	Aluminum alloy	ø12 to ø40, Anodized
		Aluminum alloy casted	ø50, Chromate, Painted
⑤	Snap ring	Carbon tool steel	Phosphate coated
⑥	Bushing	Lead-bronze casted	ø50, Spring return
			ø50, Spring extend
⑦	Return spring	Piano wire	Zinc chromated
⑧	Bronze element	Sintered metallic BC	Port size Rc 1/8, 1/4
⑨	Snap ring	Carbon tool steel	
⑩	Plug with fixed orifice	Alloy steel	Port size M5 x 0.8
⑪	Steel balls	Bearing steel	
⑫	Hexagon socket head set screw	Alloy steel	Zinc chromated
⑬	Magnet	—	
⑭	Piston seal	NBR	
⑮	Rod seal	NBR	
⑯	Gasket	NBR	

* On spring extend (Type T), piston and piston rod are integrated (stainless steel).

Replacement Parts: Seal Kit

Bore size (mm)	Seal kit no.	Contents
12	CQ2B12-PS	Set of left nos. ⑭, ⑮, ⑯
16	CQ2B16-PS	
20	CQ2B20-PS	
25	CQ2B25-PS	
32	CQ2B32-PS	
40	CQ2B40-PS	
50	CQ2B50-PS	

* Seal kit includes ⑭, ⑮, ⑯. Order the seal kit, based on each bore size.

Compact Cylinder with Auto Switch: Axial Piping Type Single Acting, Single Rod, Spring Return/Extend Series **CDQP2**

Mounting Bolt for CDQP2 with Auto Switch

Mounting method: Mounting bolt for through-hole mounting style of CDQP2B is available as an option.

Ordering: Add the word "Bolt" in front of the bolts to be used.

Example) Bolt M3 x 35ℓ 2 pcs.

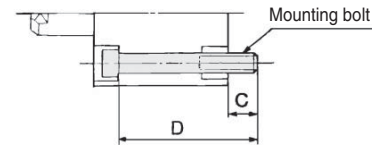
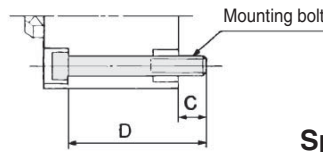

Spring Return

Model	C	D	Mounting bolt
CDQP2B12-5S	5.5	35	M3 x 35ℓ
-10S		40	x 40ℓ
CDQP2B16-5S	8	40	M3 x 40ℓ
-10S		45	x 45ℓ
CDQP2B20-5S	10.5	40	M5 x 40ℓ
-10S		45	x 45ℓ
CDQP2B25-5S	9.5	40	M5 x 40ℓ
-10S		45	x 45ℓ
CDQP2B32-5S	9	40	M5 x 40ℓ
-10S		45	x 45ℓ
CDQP2B40-5S	7.5	45	M5 x 45ℓ
-10S		50	x 50ℓ
CDQP2B50-10S	12.5	55	M6 x 55ℓ
-20S		60	x 60ℓ

Spring Extend

Model	C	D	Mounting bolt
CDQP2B12-5T	6.1	40	M3 x 40ℓ
-10T		45	x 45ℓ
CDQP2B16-5T	8	40	M3 x 40ℓ
-10T		45	x 45ℓ
CDQP2B20-5T	10.5	40	M5 x 40ℓ
-10T		45	x 45ℓ
CDQP2B25-5T	9.5	40	M5 x 40ℓ
-10T		45	x 45ℓ
CDQP2B32-5T	9	40	M5 x 40ℓ
-10T		45	x 45ℓ
CDQP2B40-5T	7.5	45	M5 x 45ℓ
-10T		50	x 50ℓ
CDQP2B50-10T	12.5	55	M6 x 55ℓ
-20T		65	x 65ℓ

Proper Auto Switch Mounting Position (Detection at stroke end) and Its Mounting

D-A7□
D-A80

D-A7□H
D-A80H
D-F7□
D-J79

D-F7□W
D-J79W
D-F79F
D-F7NTL
D-F7BAL

D-A73C
D-A80C
D-J79C

D-A79W
D-F7□WV
D-F7□V
D-F7BAVL

ø12 to ø25

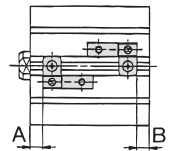
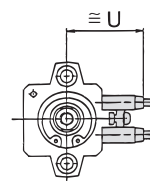
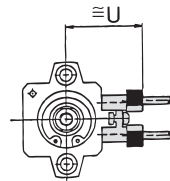
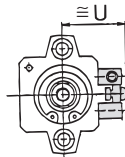
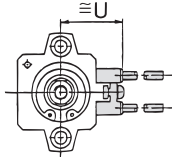

ø32 to ø100

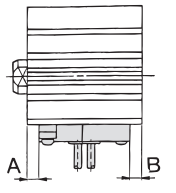
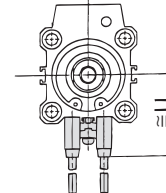
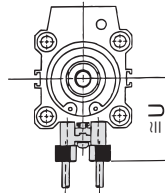
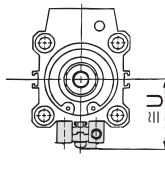
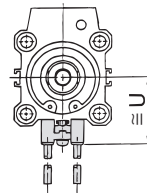

Proper Auto Switch Mounting Position/ Spring Return (Spring extend)

Bore size (mm)	D-A7□ D-A80		D-A7□H/A80H D-A73C/A80C D-F7□/J79 D-F7□V/J79C D-F7BAL/F7□W D-J79W/F7□WV D-F7BAVL/F79F		D-A79W	
	A	B	A	B	A	B
12	4.5	5.5(10)	5	6(10.5)	2	3(7.5)
16	7.5(5.5)	5(7)	8(6)	5.5(7.5)	5(3)	2.5(4.5)
20	7.5	6.5	8	7	5	4
25	7.5	7	8	7.5	5	4.5
32	9	6	9.5	6.5	6.5	3.5
40	13	8.5	13.5	9	10.5	6
50	11	11.5	11.5	12	8.5	9

(): Denotes spring extend.

Auto Switch Mounting Height

(mm)

D-A7□ D-A80	D-A7□H/A80H D-F7□/J79/F7□W D-J79W/F7BAL D-F79F/F7NTL	D-A73C D-A80C	D-F7□V D-F7□WV D-F7BAVL	D-J79C	D-A79W
U	U	U	U	U	U
19.5	20.5	26.5	23	26	22
22.5	23.5	29.5	26	29	25
24.5	25.5	31.5	28	31	27
27.5	28.5	34.5	31	34	30
31.5	32.5	38.5	35	38	34
35	36	42	38.5	41.5	37.5
41	42	48	44.5	47.5	43.5

Series CDQP2

Dimensions: $\phi 12$ to $\phi 50$ /Spring Return without Auto Switch

$\phi 12$ to $\phi 25$

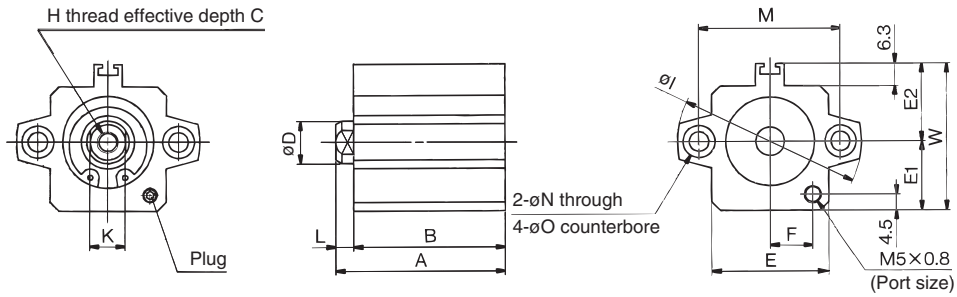

Rod end male thread

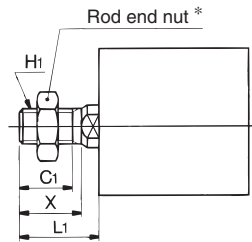

Rod End Male Thread

Bore size (mm)	C1	X	H1	L1
12	9	10.5	M5 x 0.8	14
16	10	12	M6 x 1.0	15.5
20	12	14	M8 x 1.25	18.5
25	15	17.5	M10 x 1.25	22.5

Basic Style

Bore size (mm)	A		B		C	D	E	E1	E2	F	H	I	K	L	M	N	O	W
	5 st	10 st	5 st	10 st														
12	25.5	30.5	22	27	6	6	23	13	14	7	M3 x 0.5	32	5	3.5	22	3.5	6.5 depth 3.5	27
16	27	32	23.5	28.5	8	8	26	15	17	8.5	M4 x 0.7	38	6	3.5	28	3.5	6.5 depth 3.5	32
20	29	34	24.5	29.5	7	10	30	17	19	10.5	M5 x 0.8	47	8	4.5	36	5.5	9 depth 7	36
25	32.5	37.5	27.5	32.5	12	12	33	19.5	22	12	M6 x 1.0	52	10	5	40	5.5	9 depth 7	41.5

$\phi 32$ to $\phi 50$

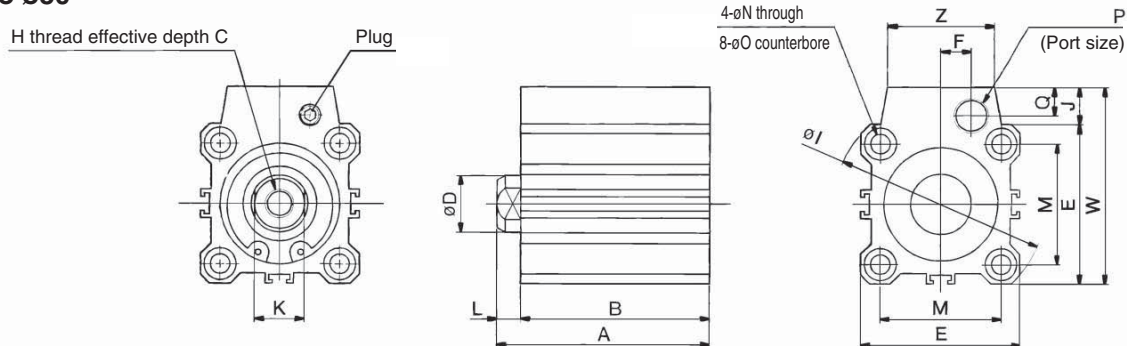

Rod end male thread

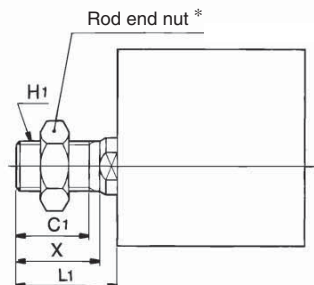

Rod End Male Thread

Bore size (mm)	C1	X	H1	L1
32	20.5	23.5	M14 x 1.5	28.5
40	20.5	23.5	M14 x 1.5	28.5
50	26	28.5	M18 x 1.5	33.5

Basic Style

Bore size (mm)	A			B			C	D	E	F	H	I	J	K	L	M	N	O	P	Q	W	Z
	5 st	10 st	20 st	5 st	10 st	20 st																
32	35	40	—	28	33	—	13	16	45	8.5	M8 x 1.25	60	10.5	14	7	34	5.5	9 depth 7	Rc 1/8	8	55.5	30
40	41.5	46.5	—	34.5	39.5	—	13	16	52	8.5	M8 x 1.25	69	10	14	7	40	5.5	9 depth 7	Rc 1/8	8	62	30
50	—	48.5	58.5	—	40.5	50.5	15	20	64	11	M10 x 1.5	86	13	17	8	50	6.6	11 depth 8	Rc 1/4	10	77	39

For details about the rod end nut and accessory brackets, refer to page 7-6-20.



Compact Cylinder with Auto Switch: Axial Piping Type Single Acting, Single Rod, Spring Return/Extend Series **CDQP2**

Dimensions: $\phi 12$ to $\phi 50$ /Spring Return with Auto Switch

$\phi 12$ to $\phi 25$

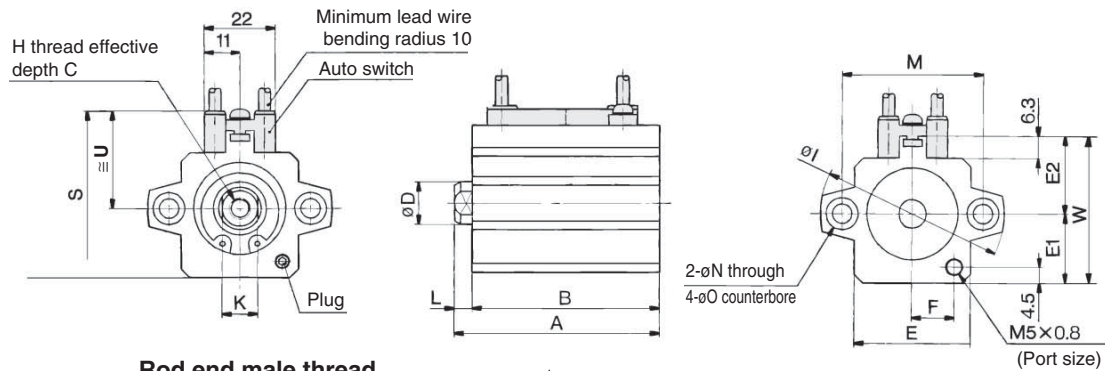

Rod end male thread

Auto switch shown above is D-A73 and D-A80. For auto switch mounting position and its mounting height, refer to page 7-6-103.

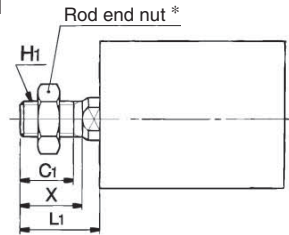

Rod End Male Thread

Bore size (mm)	C1	X	H1	L1
12	9	10.5	M5 x 0.8	14
16	10	12	M6 x 1.0	15.5
20	12	14	M8 x 1.25	18.5
25	15	17.5	M10 x 1.25	22.5

Basic Style

Bore size (mm)	A		B		C	D	E	E1	E2	F	H	I	K	L	M	N	O	S	U	W
	5 st	10 st	5 st	10 st																
12	36.5	41.5	33	38	6	6	23	13	14	7	M3 x 0.5	32	5	3.5	22	3.5	6.5 depth 3.5	32.5	19.5	27
16	39	44	35.5	40.5	8	8	26	15	17	8.5	M4 x 0.7	38	6	3.5	28	3.5	6.5 depth 3.5	37.5	22.5	32
20	41	46	36.5	41.5	7	10	30	17	19	10.5	M5 x 0.8	47	8	4.5	36	5.5	9 depth 7	41.5	24.5	36
25	42.5	47.5	37.5	42.5	12	12	33	19.5	22	12	M6 x 1.0	52	10	5	40	5.5	9 depth 7	47	27.5	41.5

$\phi 32$ to $\phi 50$

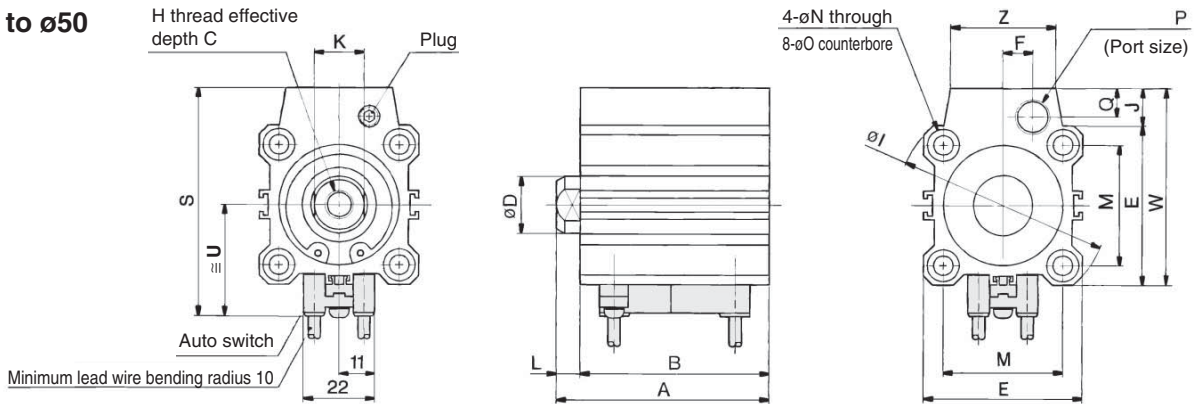

Rod end male thread

Auto switch shown above is D-A73 and D-A80. For the auto switch mounting position and its mounting height, refer to page 7-6-103.

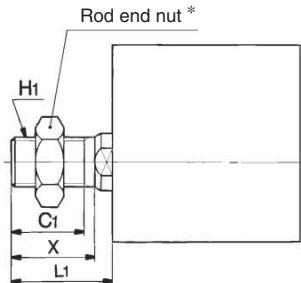

Rod End Male Thread

Bore size (mm)	C1	X	H1	L1
32	20.5	23.5	M14 x 1.5	28.5
40	20.5	23.5	M14 x 1.5	28.5
50	26	28.5	M18 x 1.5	33.5

Basic Style

Bore size (mm)	A			B			C	D	E	F	H	I	J	K	L	M	N	O	P	Q	S	U	W	Z
	5 st	10 st	20 st	5 st	10 st	20 st																		
32	45	50	—	38	43	—	13	16	45	8.5	M8 x 1.25	60	10.5	14	7	34	5.5	9 depth 7	Rc 1/8	8	64.5	31.5	55.5	30
40	51.5	56.5	—	44.5	49.5	—	13	16	52	8.5	M8 x 1.25	69	10	14	7	40	5.5	9 depth 7	Rc 1/8	8	71	35	62	30
50	—	58.5	68.5	—	50.5	60.5	15	20	64	11	M10 x 1.5	86	13	17	8	50	6.6	11 depth 8	Rc 1/4	10	86	41	77	39

* For details about the rod end nut and accessory brackets, refer to page 7-6-20.

Series CDQP2

Dimensions: $\phi 12$ to $\phi 50$ /Spring Extend without Auto Switch

$\phi 12$ to $\phi 25$

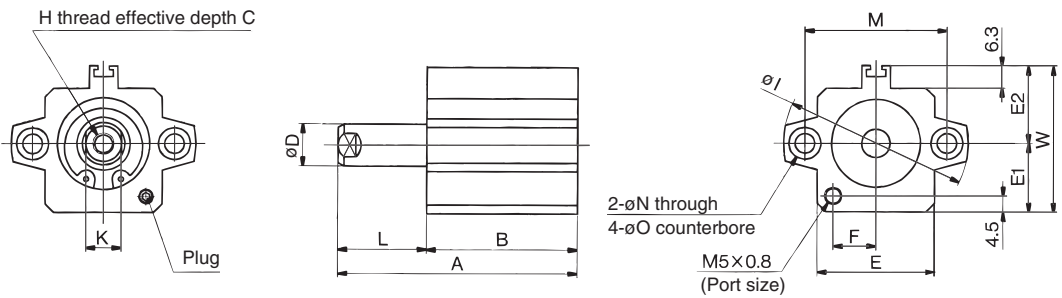

Rod end male thread

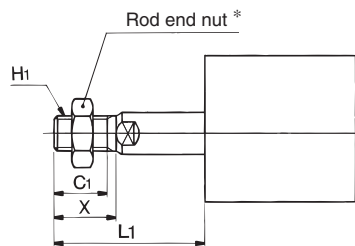

Rod End Male Thread

Bore size (mm)	C1	H1	L1		X
			5 st	10 st	
12	9	M5 x 0.8	19	24	10.5
16	10	M6 x 1.0	20.5	25.5	12
20	12	M8 x 1.25	23.5	28.5	14
25	15	M10 x 1.25	27.5	32.5	17.5

Basic Style

Bore size (mm)	A		B		C	D	E	E ₁	E ₂	F	H	I	K	L		M	N	O	W
	5 st	10 st	5 st	10 st										5 st	10 st				
12	30.5	40.5	22	27	6	6	23	13	14	7	M3 x 0.5	32	5	8.5	13.5	22	3.5	6.5 depth 3.5	27
16	32	42	23.5	28.5	8	8	26	15	17	8.5	M4 x 0.7	38	6	8.5	13.5	28	3.5	6.5 depth 3.5	32
20	34	44	24.5	29.5	7	10	30	17	19	10.5	M5 x 0.8	47	8	9.5	14.5	36	5.5	9 depth 7	36
25	37.5	47.5	27.5	32.5	12	12	33	19.5	22	12	M6 x 1.0	52	10	10	15	40	5.5	9 depth 7	41.5

$\phi 32$ to $\phi 50$

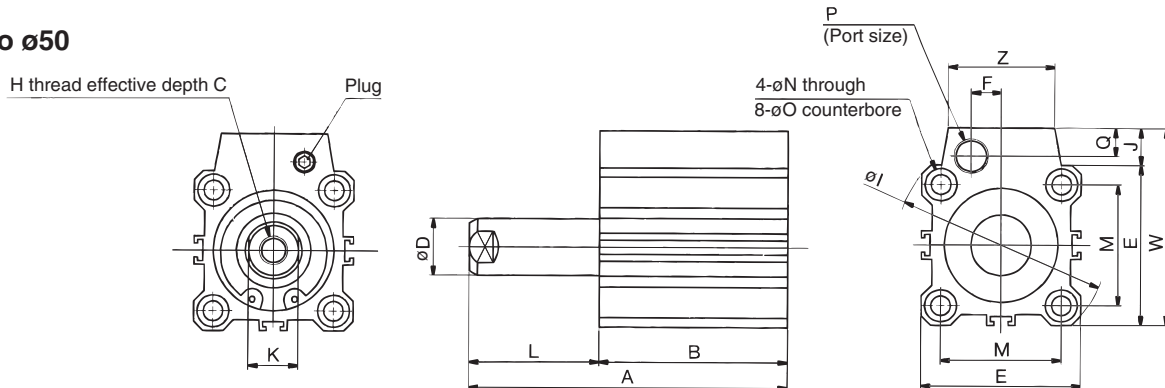

Rod end male thread

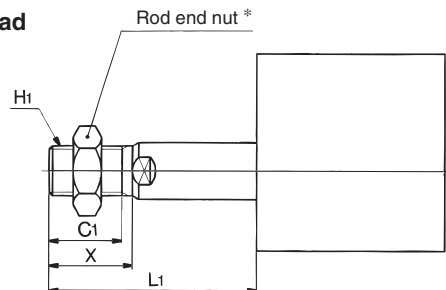

Rod End Male Thread

Bore size (mm)	C1	X	H1	L1		
				5 st	10 st	20 st
32	20.5	23.5	M14 x 1.5	33.5	38.5	—
40	20.5	23.5	M14 x 1.5	33.5	38.5	—
50	26	28.5	M18 x 1.5	—	43.5	53.5

Basic Style

Bore size (mm)	A			B			C	D	E	F	H	I	J	K	L			M	N	O	P	Q	W	Z
	5 st	10 st	20 st	5 st	10 st	20 st									5 st	10 st	20 st							
32	40	50	—	28	33	—	13	16	45	8.5	M8 x 1.25	60	10.5	14	12	17	—	34	5.5	9 depth 7	Rc 1/8	8	55.5	30
40	46.5	56.5	—	34.5	39.5	—	13	16	52	8.5	M8 x 1.25	69	10	14	12	17	—	40	5.5	9 depth 7	Rc 1/8	8	62	30
50	—	58.5	78.5	—	40.5	50.5	15	20	64	11	M10 x 1.5	86	13	17	—	18	28	50	6.6	11 depth 8	Rc 1/4	10	77	39



* For details about the rod end nut and accessory brackets, refer to page 7-6-20.

Compact Cylinder with Auto Switch: Axial Piping Type Single Acting, Single Rod, Spring Return/Extend Series **CDQP2**

Dimensions: $\phi 12$ to $\phi 50$ /Spring Extend with Auto Switch

$\phi 12$ to $\phi 25$

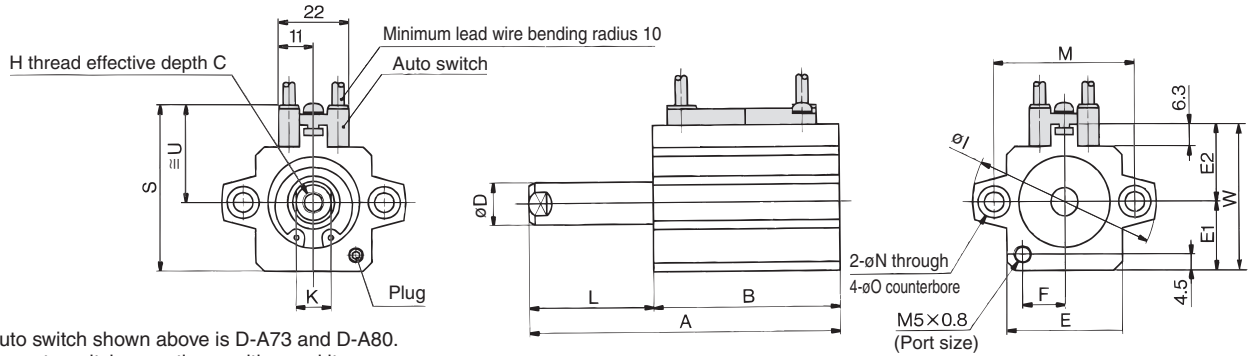

Auto switch shown above is D-A73 and D-A80.
For auto switch mounting position and its mounting height, refer to page 7-6-103.

Rod end male thread

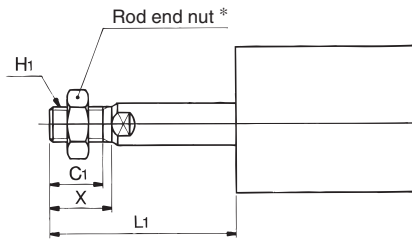

Rod End Male Thread

Bore size (mm)	C1	X	H1	L1	
				5 st	10 st
12	9	10.5	M5 x 0.8	19	24
16	10	12	M6 x 1.0	20.5	25.5
20	12	14	M8 x 1.25	23.5	28.5
25	15	17.5	M10 x 1.25	27.5	32.5

Basic Style

Bore size (mm)	A		B		C	D	E	E1	E2	F	H	I	K	L			M	N	O	S	U	W
	5 st	10 st	5 st	10 st										5 st	10 st							
12	45.9	55.9	37.4	42.4	6	6	23	13	14	7	M3 x 0.5	32	5	8.5	13.5	22	3.5	6.5 depth 3.5	32.5	19.5	27	
16	44	54	35.5	40.5	8	8	26	15	17	8.5	M4 x 0.7	38	6	8.5	13.5	28	3.5	6.5 depth 3.5	37.5	22.5	32	
20	46	56	36.5	41.5	7	10	30	17	19	10.5	M5 x 0.8	47	8	9.5	14.5	36	5.5	9 depth 7	41.5	24.5	36	
25	47.5	57.5	37.5	42.5	12	12	33	19.5	22	12	M6 x 1.0	52	10	10	15	40	5.5	9 depth 7	47	27.5	41.5	

$\phi 32$ to $\phi 50$

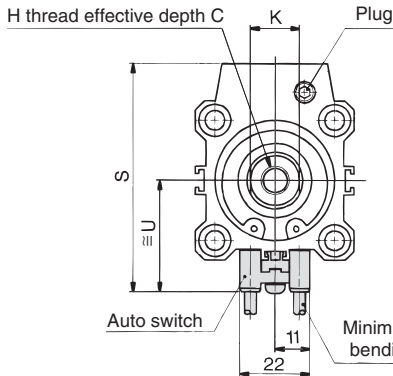

Auto switch shown above is D-A73 and D-A80.
For the auto switch mounting position and its mounting height, refer to page 7-6-103.

Rod end male thread

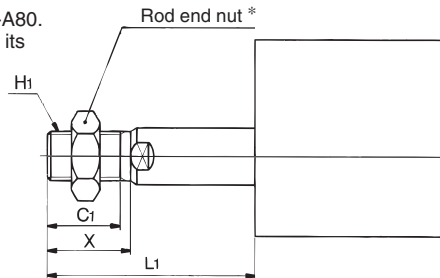

Rod End Male Thread

Bore size (mm)	C1	X	H1	L1		
				5 st	10 st	20 st
32	20.5	23.5	M14 x 1.5	33.5	38.5	—
40	20.5	23.5	M14 x 1.5	33.5	38.5	—
50	26	28.5	M18 x 1.5	—	43.5	53.5

Basic Style

Bore size (mm)	A			B			C	D	E	F	H	I	J	K	L			M	N	O	P	Q	S	U	W	Z
	5 st	10 st	20 st	5 st	10 st	20 st									5 st	10 st	20 st									
32	50	60	—	38	43	—	13	16	45	8.5	M8 x 1.25	60	10.5	14	12	17	—	34	5.5	9 depth 7	Rc 1/8	8	64.5	31.5	55.5	30
40	56.5	66.5	—	44.5	49.5	—	13	16	52	8.5	M8 x 1.25	69	10	14	12	17	—	40	5.5	9 depth 7	Rc 1/8	8	71	35	62	30
50	—	68.5	88.5	—	50.5	60.5	15	20	64	11	M10 x 1.5	86	13	17	—	18	28	50	6.6	11 depth 8	Rc 1/4	10	86	41	77	39

* For details about the rod end nut and accessory brackets, refer to page 7-6-20.



Compact Cylinder: Large Bore Size Type Double Acting, Single Rod

Series CQ2

ø125, ø140, ø160, ø180, ø200

How to Order

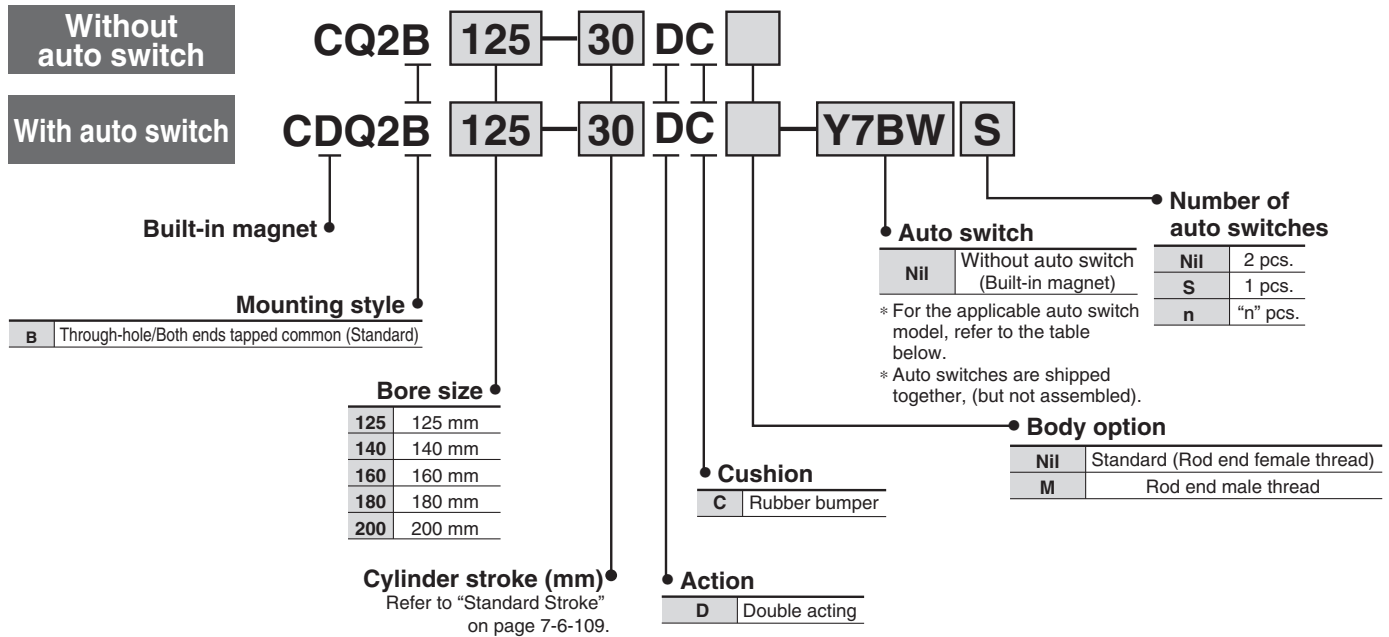

Applicable Auto Switch/Refer to page 7-9-1 for further information on auto switches.

Type	Special function	Electrical entry	Indicator/light	Wiring (Output)	Load voltage		Rail mounting		Direct mounting		Lead wire length (m) *				Pre-wire connector	Applicable load			
					DC	AC	ø125 to ø160		ø125 to ø200		0.5 (Nil)	3 (L)	5 (Z)	None (N)		IC circuit	Relay, PLC		
							Perpendicular	In-line	Perpendicular	In-line									
Reed switch	—	Grommet	Yes	3-wire (NPN equivalent)	—	5 V	—	A76H	—	Z76	●	●	—	—	—	—	IC circuit		
				Connector	—	—	200 V	A72	A72H	—	—	●	●	—	—	—	—	—	—
	Diagnostic indication (2-color indication)	Grommet	2-wire	24 V	12 V	100 V	A73	A73H	—	Z73	●	●	●	—	—	—	—	Relay, PLC	
					—	—	A73C	—	—	—	●	●	●	●	—	—	—		
Solid state switch	—	Grommet	Yes	3-wire (NPN)	5 V, 12 V	—	F7NV	F79	Y69A	Y59A	●	●	○	—	○	—	IC circuit		
				3-wire (PNP)			F7PV	F7P	Y7PV	Y7P	●	●	○	—	○	—	—	—	—
				2-wire			F7BV	J79	Y69B	Y59B	●	●	○	—	○	—	—	—	—
								J79C	—	—	●	●	●	●	—	—	—	—	
	Diagnostic indication (2-color indication)	Grommet	Yes	3-wire (NPN)	24 V	5 V, 12 V	—	F7NWV	F79W	Y7NWV	Y7NW	●	●	○	—	○	—	IC circuit	
	3-wire (PNP)			—				F7PW	Y7PWV	Y7PW	●	●	○	—	○	—	—	—	
	2-wire			F7BWV				J79W	Y7BWV	Y7BW	●	●	○	—	○	—	—	—	—
	Water resistant (2-color indication)	Grommet	Yes	2-wire	12 V	—	—	—	F7BA	—	Y7BA	—	●	○	—	○	—	—	
	With diagnostic output (2-color indication)			4-wire (NPN)				5 V, 12 V	—	—	—	—	—	—	—	●	●	○	—
							—	F79F	—	—	—	—	—	—	—	—	—		

* Lead wire length symbols: 0.5 m.....Nil (Example) A73C
3 m.....L (Example) A73CL
5 m.....Z (Example) A73CZ
None.....N (Example) A73CN

* Solid state switches marked with "○" are produced upon receipt of order.

- Since there are other applicable auto switches than listed, refer to page 7-6-23 for details.
- For details about auto switches with pre-wire connector, refer to page 7-9-36.

Compact Cylinder: Large Bore Size Type Double Acting, Single Rod Series CQ2

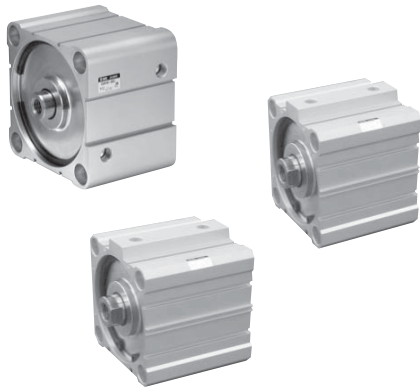

JIS Symbol
Double acting,
Single rod

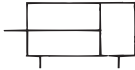

Made to Order Specifications
(For details, refer to page 7-10-1.)

Symbol	Specifications
-XB10	Intermediate stroke (Using exclusive body)
-XC18	NPT finish piping port
-X271	Fluoro rubber for seals

⚠ Precautions

Be sure to read before handling.
For Safety Instructions and
Actuator Precautions, refer to
pages 7-13-3 to 7-13-6.

⚠ Caution

Snap Ring Installation/Removal

- For installation and removal, use an appropriate pair of pliers (tool for installing a type C snap ring).
- Even if a proper plier (tool for installing type C snap ring) is used, it is likely to inflict damage to a human body or peripheral equipment, as a snap ring may be flown out of the tip of a plier (tool for installing a type C snap ring). Be much careful with the popping of a snap ring. Besides, be certain that a snap ring is placed firmly into the groove of rod cover before supplying air at the time of installment.

Type

Bore size (mm)		125	140	160	180	200
Pneumatic	Mounting Through-hole/Both ends tapped (Common)	●	●	●	●	●
	Built-in magnet	●	●	●	●	●
	Piping Screw-in type	Rc 3/8	Rc 3/8	Rc 3/8	Rc 1/2	Rc 1/2
	Rod end male thread	●	●	●	●	●
	Rubber bumper (Standard)	●	●	●	●	●

Specifications

Bore size (mm)	125	140	160	180	200
Type	Pneumatic (Non-lube)				
Fluid	Air				
Proof pressure	1.5 MPa			1.05 MPa	
Maximum operating pressure	1.0 MPa			0.7 MPa	
Ambient and fluid temperature	Without auto switch: -10 to 70°C (No freezing) With auto switch: -10 to 60°C (No freezing)				
Cushion	Rubber bumper (Standard)				
Rod end thread	Female thread				
Rod end thread tolerance	JIS Class 2				
Stroke length tolerance	$\begin{matrix} +1.4 \\ 0 \end{matrix}$				
Mounting	Through-hole/Both ends tapped (Common)				
Piston speed	50 to 500 mm/s			20 to 400 mm/s	

Minimum Operating Pressure

Bore size (mm)	125	140	160	180	200
Minimum operating pressure	0.05				

Allowable Kinetic Energy

Bore size (mm)	125	140	160	180	200
Allowable kinetic energy	7.4	9.8	12.4		

Standard Stroke

Bore size (mm)	Standard stroke
125, 140, 160, 180, 200	10, 20, 30, 40, 50, 75, 100, 125, 150, 175, 200, 250, 300

Manufacture of Intermediate Stroke

Description	Spacer is installed in the standard stroke body.	Exclusive body (-XB10)								
Part no.	Refer to "How to Order" for the standard model no. on page 7-6-108.	Suffix "-XB10" to the end of standard model no. on page 7-6-108.								
Description	Dealing with the stroke by the 5 mm interval is available by installing spacer with standard stroke cylinder.	Dealing with the stroke by the 1 mm interval by using an exclusive body with the specified stroke.								
Stroke range	<table border="1"> <thead> <tr> <th>Bore size</th> <th>Stroke range</th> </tr> </thead> <tbody> <tr> <td>125 to 200</td> <td>5 to 295</td> </tr> </tbody> </table>	Bore size	Stroke range	125 to 200	5 to 295	<table border="1"> <thead> <tr> <th>Bore size</th> <th>Stroke range</th> </tr> </thead> <tbody> <tr> <td>125 to 160</td> <td>11 to 299</td> </tr> </tbody> </table>	Bore size	Stroke range	125 to 160	11 to 299
Bore size	Stroke range									
125 to 200	5 to 295									
Bore size	Stroke range									
125 to 160	11 to 299									
Example	Part no.: CQ2B160-165DC CQ2B160-175DC with 10 mm width spacer. B dimension is 266 mm.	Part no.: CQ2B160-165DC-XB10 Makes 165 stroke tube. B dimension is 256 mm.								

Minimum Stroke for Auto Switch Mounting

No. of auto switches mounted	D-F7□/F7□V D-J79/J79C D-Y59□/Y69□ D-Y7P/Y7PV	D-A7□, D-A80 D-A73C, D-A80C D-A7□H, D-Z7□ D-Z80, D-A80H	D-F7□W/F7□WV D-J79W D-F7BAL/F7BAVL D-F7NTL/F79F D-F7□W/Y7□WV D-Y7BAL	D-A79W
1 pc.	5	5	10	15
2 pcs.	5	10	15	20

CUJ

CU

CQS

CQM

CQ2

RQ

MU

D-

-X

20-

Data

Series CQ2

Theoretical Output

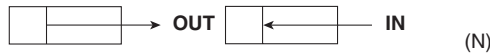

Bore size (mm)	Operating direction	Operating pressure (MPa)		
		0.3	0.5	0.7
125	IN	3376	5627	7878
	OUT	3682	6136	8590
140	IN	4313	7188	10063
	OUT	4618	7697	10776
160	IN	5655	9425	13195
	OUT	6032	10053	14074
180	IN	7257	12095	16933
	OUT	7634	12724	17813
200	IN	9048	15080	21112
	OUT	9425	15708	21991

Weight

Without Auto Switch

(kg)

Bore size (mm)	Cylinder stroke (mm)												
	10	20	30	40	50	75	100	125	150	175	200	250	300
125	5.48	5.74	6.00	6.26	6.52	7.17	7.81	8.46	9.11	9.76	10.41	11.71	13.01
140	6.49	6.78	7.08	7.38	7.68	8.42	9.17	9.91	10.66	11.40	12.15	13.64	15.13
160	8.96	9.31	9.67	10.03	10.39	11.29	12.19	13.09	13.99	14.89	15.79	17.59	19.38
180	11.97	12.39	12.81	13.24	13.67	14.73	15.80	16.87	17.93	18.99	20.05	22.18	24.31
200	15.30	15.87	16.35	16.84	17.33	18.55	19.77	20.99	22.21	23.43	24.74	27.08	29.52

Built-in Magnet

(kg)

Bore size (mm)	Cylinder stroke (mm)												
	10	20	30	40	50	75	100	125	150	175	200	250	300
125	5.54	5.80	6.06	6.32	6.58	7.23	7.87	8.52	9.17	9.82	10.47	11.77	13.07
140	6.56	6.85	7.15	7.45	7.75	8.49	9.24	9.98	10.73	11.47	12.22	13.71	15.20
160	9.04	9.39	9.75	10.11	10.47	11.37	12.27	13.17	14.07	14.97	15.87	17.67	19.46
180	12.05	12.47	12.89	13.32	13.75	14.81	15.88	16.95	18.01	19.07	20.13	22.26	24.39
200	15.38	15.95	16.43	16.92	17.41	18.63	19.85	21.07	22.29	23.51	24.82	27.16	29.60

Mounting Bolt for CQ2

Mounting method: Mounting bolt for through-hole mounting style of CQ2B is available as an option.

Ordering: Add the word "Bolt" in front of the bolts to be used.

Example) Bolt M12 x 100ℓ 4 pcs.

Note 1) To install a through-hole type mounting bolt, make sure to use the flat washer that is provided.

Note 2) Please consult with SMC regarding mounting bolts for strokes that exceed 100 mm. Use the OA screw provided on the cylinder tube to secure the cylinder.

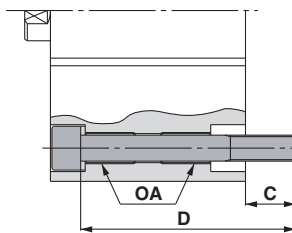

Model	C	D	Mounting bolt	Model	C	D	Mounting bolt
C□Q2B125/140-10DC	22.9	100	M12 x 100ℓ	C□Q2B180-10DC	36	125	M18 x 125ℓ
-20DC		110	x 110ℓ	-20DC		135	x 135ℓ
-30DC		120	x 120ℓ	-30DC		145	x 145ℓ
-40DC		130	x 130ℓ	-40DC		155	x 155ℓ
-50DC		140	x 140ℓ	-50DC		165	x 165ℓ
-75DC		165	x 165ℓ	-75DC		190	x 190ℓ
-100DC		190	x 190ℓ	-100DC		215	x 215ℓ
C□Q2B160-10DC	27.7	110	M14 x 110ℓ	C□Q2B200-10DC	39	135	M18 x 135ℓ
-20DC		120	x 120ℓ	-20DC		145	x 145ℓ
-30DC		130	x 130ℓ	-30DC		155	x 155ℓ
-40DC		140	x 140ℓ	-40DC		165	x 165ℓ
-50DC		150	x 150ℓ	-50DC		175	x 175ℓ
-75DC		175	x 175ℓ	-75DC		200	x 200ℓ
-100DC		200	x 200ℓ	-100DC		225	x 225ℓ

Compact Cylinder: Large Bore Size Type Double Acting, Single Rod Series CQ2

Additional Weight

(kg)

Bore size (mm)		125	140	160, 180, 200
Rod end male thread	Male thread	0.31	0.31	0.48
	Nut	0.16	0.16	0.26

Calculation: (Example) CDQ2B125-30DCM Add the weight of auto switches
 • Cylinder weight: CDQ2B125-30DC.....6.06 kg and mounting brackets.
 • Option weight: Rod end male thread.....0.47 kg
 6.53 kg

Auto Switch Mounting Bracket Weight

Mounting bracket part no.	Applicable bore size (mm)	Weight (g)
BQ-2	125 to 160	1.5

For auto switch weight, refer to page 7-9-1.

Construction

Double acting, Single rod

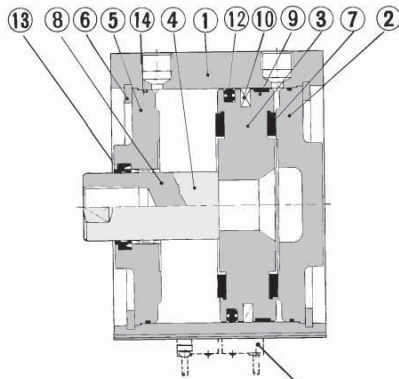

Rod end male thread

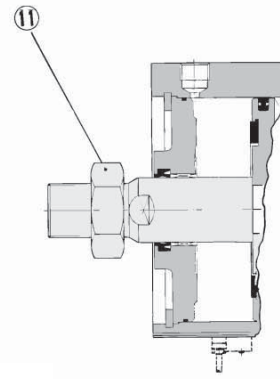

Auto switch (D-A7□, D-A80)
 For only ø125, ø140, ø160

Component Parts

No.	Description	Material	Note
①	Cylinder tube	Aluminum alloy	Hard anodized
②	Head cover	Cast iron	Nickel plated
③	Piston	Aluminum alloy	Chromated
④	Piston rod	Carbon steel	Hard chrome plated
⑤	Rod cover	Cast iron	Nickel plated
⑥	Snap ring	Carbon tool steel	Phosphate coated
⑦	Bumper	Urethane	
⑧	Bushing	Lead-bronze casted	
⑨	Wear ring	Resin	
⑩	Magnet	—	For only CDQ2B□
⑪	Rod end nut	Carbon steel	Nickel plated
⑫	Piston seal	NBR	
⑬	Rod seal	NBR	
⑭	Tube gasket	NBR	

Replacement Parts: Seal Kit

Bore size (mm)	Kit no.	Contents
125	CQ2B125-PS	Set of left nos. ⑫, ⑬, ⑭
140	CQ2B140-PS	
160	CQ2B160-PS	
180	CQ2B180-PS	
200	CQ2B200-PS	

* Seal kit includes ⑫, ⑬, ⑭. Order the seal kit, based on each bore size.

Auto Switch Mounting Bracket Part No.

Bore size (mm)	Mounting bracket part no.	Note	Applicable auto switch	
			Reed switch	Solid state switch
125 140 160	BQ-2	<ul style="list-style-type: none"> Switch mounting screw (M3 x 0.5 x 10ϕ) Switch spacer Switch mounting nut 	D-A7□/A80 D-A73C/A80C D-A7□H/A80H D-A79W	D-F7□/J79 D-F7□V D-J79C D-F7□W/J79W D-F7□WV D-F7BAL/F7BAVL D-F79F, D-F7NTL

[Mounting screws set made of stainless steel]

The set of stainless steel mounting screws (with nuts) described below is available and can be used depending on the operating environment. (Please order the auto switch spacer, since it is not included.)

BBA2: For D-A7/A8/F7/J7

"D-F7BAL/F7BAVL" switch is set on the cylinder with the stainless steel screws above when shipped. When only a switch is shipped independently, "BBA2" screws are attached.

Rod End Nut

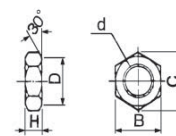

Material: Carbon steel

Part no.	Applicable bore size (mm)	d	H	B	C	D
NT-12	125, 140	M30 x 1.5	18	46	53.1	44
NT-16	160, 180, 200	M36 x 1.5	21	55	63.5	53

CUJ
 CU
 CQS
 CQM
CQ2
 RQ
 MU
 D-
 -X
 20-
 Data

Compact Cylinder: Large Bore Size Type Double Acting, Single Rod Series CQ2

Dimensions: $\phi 180$, $\phi 200$

The dimensions are the same with or without an auto switch.

$\phi 180$

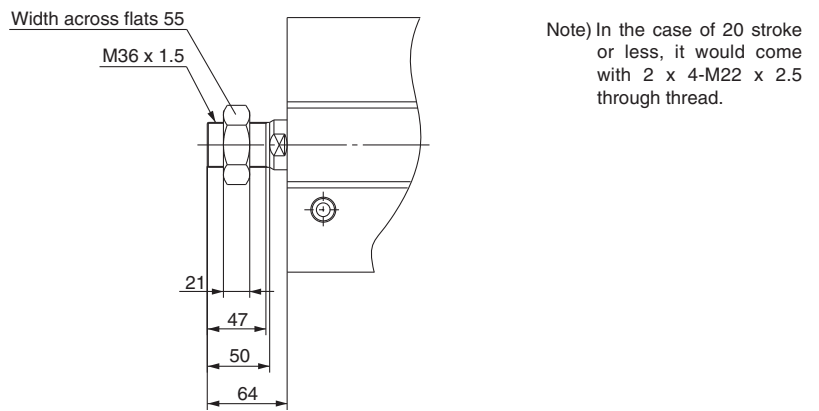
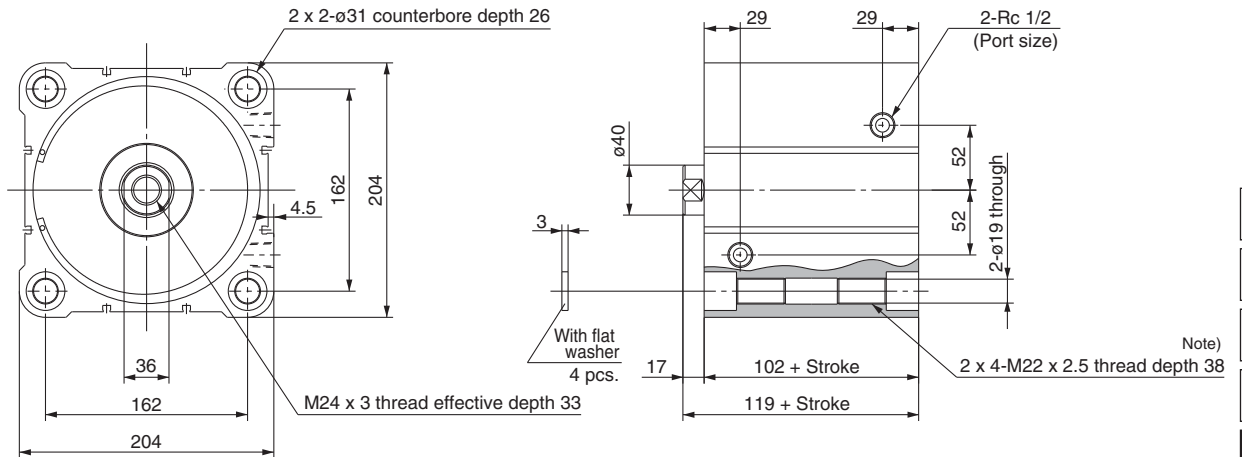

$\phi 200$

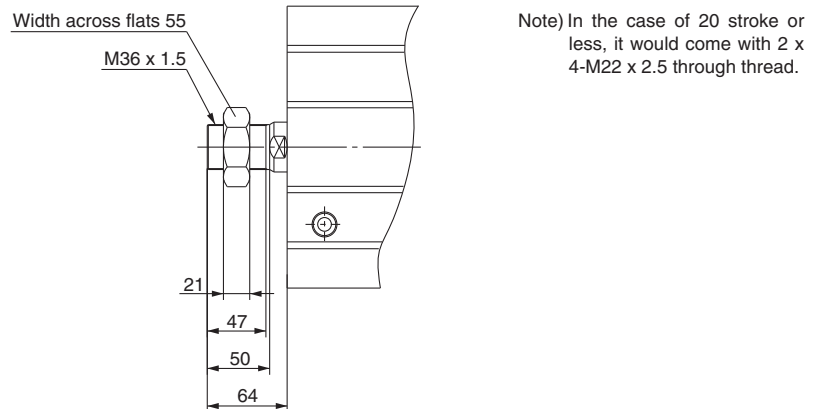
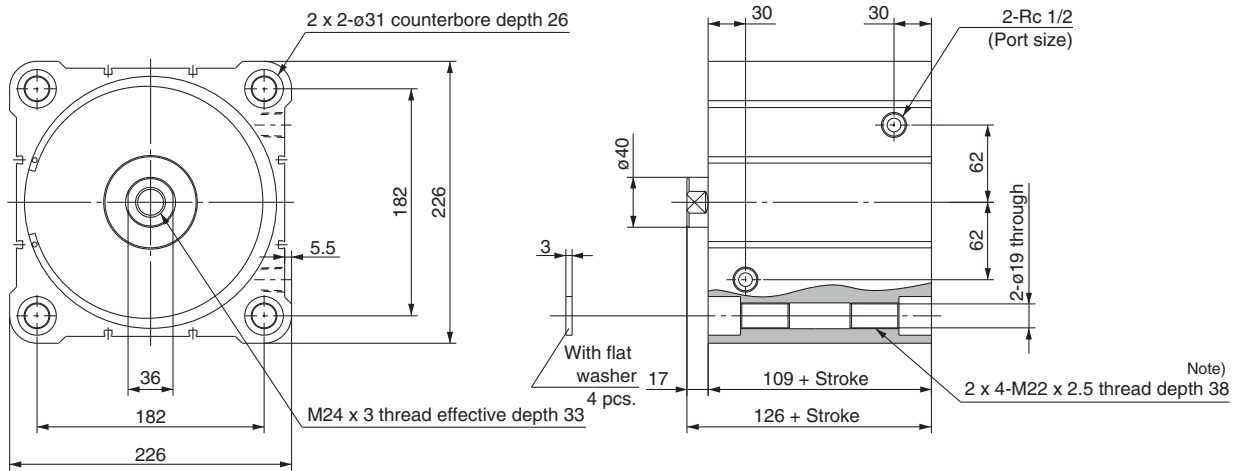

CUJ

CU

CQS

CQM

CQ2

RQ

MU

D-

-X

20-

Data

Series CQ2

Proper Auto Switch Mounting Position (Detection at stroke end) and Its Mounting Height

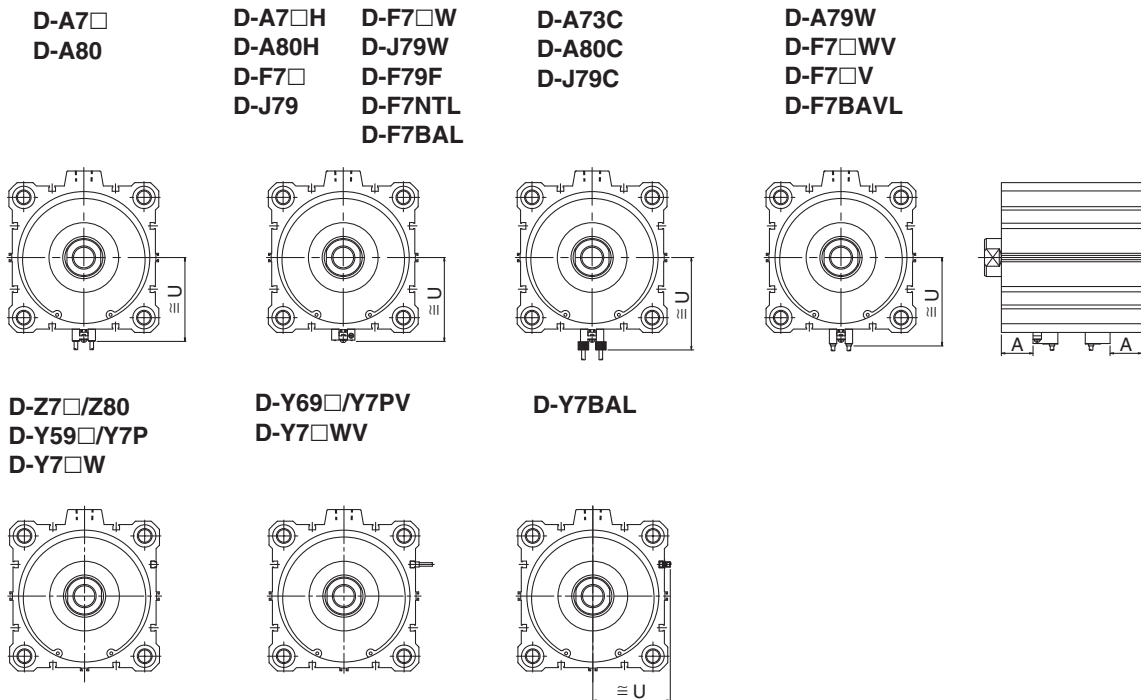

Proper Auto Switch Mounting Position

Bore size (mm)	D-A7□ D-A80	D-A7□H/A80H D-A73C/A80C D-F□/F7□V/F79F D-F7□W/F7□WV D-J79/J79W D-J79C D-F7BAL/F7BAVL	D-A79W	D-F7NNTL	D-Z7□/Z80 D-Y59□/Y69□ D-F7P/Y7PV D-Y7□W/Y7□WV D-Y7BAL
	A	A	A	A	A
125	32.5	33	30	38	29
140	32.5	33	30	38	29
160	36.5	37	34	42	33
180	—	—	—	—	38.5
200	—	—	—	—	42

Auto Switch Mounting Height

(mm)

D-A7□ D-A80	D-A7□H, D-A80H D-F7□, D-J79, D-F7□W D-J79W, D-F7BAL D-F79F, D-F7NNTL	D-A73C D-A80C	D-F7□V D-F7□WV D-F7BAVL	D-J79C	D-A79W	D-Y7BAL
U	U	U	U	U	U	U
80	81	87	83.5	85.5	82.5	74
88	89	95	91.5	93.5	90.5	82
98	99	105	101.5	103.5	100.5	92
—	—	—	—	—	—	103.5
—	—	—	—	—	—	113.5



Compact Cylinder: Large Bore Size Type

Double Acting, Double Rod

Series CQ2W

ø125, ø140, ø160, ø180, ø200

How to Order

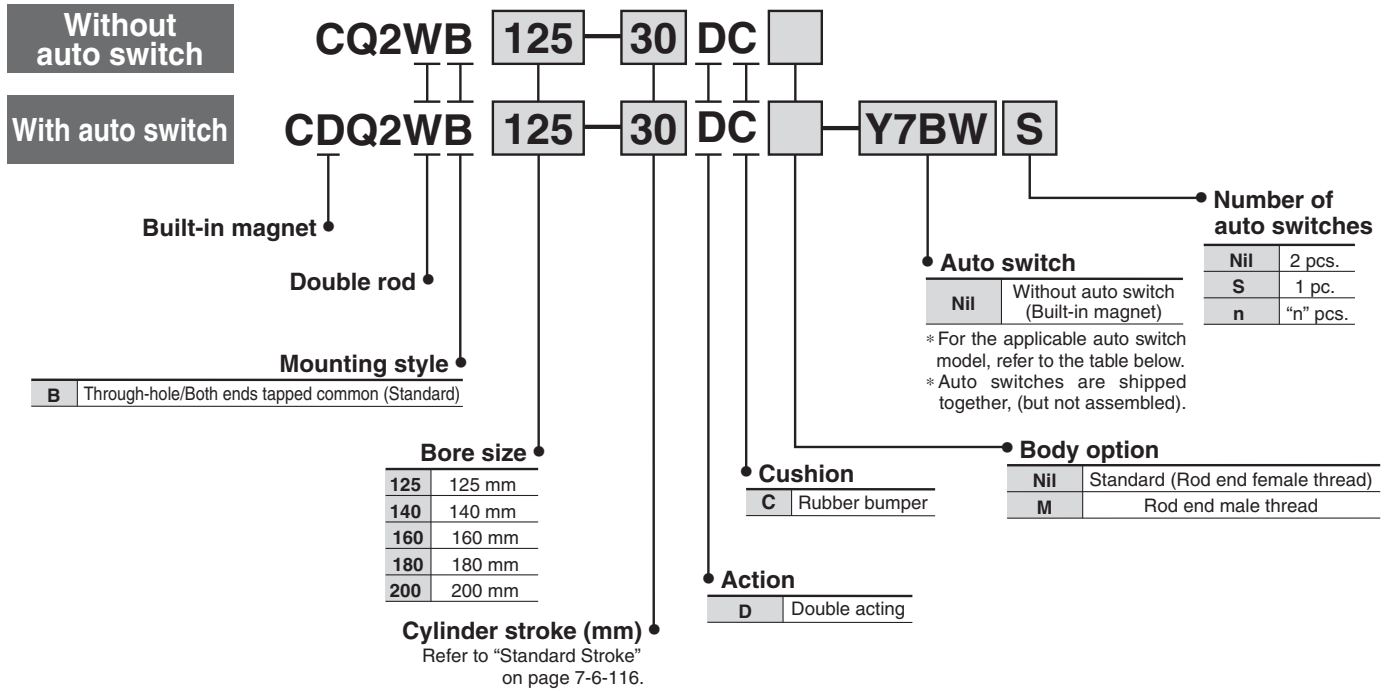

- CUJ
- CU
- CQS
- CQM
- CQ2**
- RQ
- MU
- D-
- X
- 20-
- Data

Applicable Auto Switch/Refer to page 7-9-1 for further information on auto switches.

Type	Special function	Electrical entry	Indicator light	Wiring (Output)	Load voltage		Rail mounting		Direct mounting		Lead wire length (m)*				Pre-wire connector	Applicable load		
					DC	AC	ø125 to ø160		ø125 to ø200		0.5 (Nil)	3 (L)	5 (Z)	None (N)		IC circuit	Relay, PLC	
							Perpendicular	In-line	Perpendicular	In-line								
Reed switch	—	Grommet	Yes	3-wire (NPN equivalent)	—	5 V	—	—	A76H	—	Z76	●	●	—	—	—	—	
						200 V	A72	A72H	—	—	●	●	—	—				
	Diagnostic indication (2-color indication)	Connector		2-wire	24 V	12 V	100 V	A73	A73H	—	Z73	●	●	●	—	—	—	Relay, PLC
						12 V	—	A73C	—	—	—	●	●	●	●	—		
Solid state switch	—	Grommet	Yes	3-wire (NPN)	—	5 V, 12 V	—	F7NV	F79	Y69A	Y59A	●	●	○	—	○	IC circuit	
								F7PV	F7P	Y7PV	Y7P	●	●	○	—			○
	Diagnostic indication (2-color indication)	Connector		2-wire	24 V	5 V, 12 V	—	F7BV	J79	Y69B	Y59B	●	●	○	—	○	—	—
								J79C	—	—	—	●	●	●	●	—		
	Water resistant (2-color indication)	Grommet		3-wire (NPN)	24 V	5 V, 12 V	—	F7NVV	F79W	Y7NVV	Y7NW	●	●	○	—	○	○	IC circuit
								—	F7PW	Y7PWV	Y7PW	●	●	○	—	○		
	With diagnostic output (2-color indication)	Grommet		2-wire	24 V	12 V	—	F7BWW	J79W	Y7BWW	Y7BW	●	●	○	—	○	—	—
								—	F7BA	—	Y7BA	—	●	○	—	○		
	—	Grommet		4-wire (NPN)	24 V	5 V, 12 V	—	F7BAV	—	—	—	—	●	○	—	—	—	—
								—	F79F	—	—	—	—	●	●	○		

* Lead wire length symbols: 0.5 m.....Nil (Example) A73C
 3 m.....L (Example) A73CL
 5 m.....Z (Example) A73CZ
 None.....N (Example) A73CN

* Solid state switches marked with "○" are produced upon receipt of order.

• Since there are other applicable auto switches than listed, refer to page 7-6-23 for details.
 • For details about auto switches with pre-wire connector, refer to page 7-9-36.



Series CQ2W

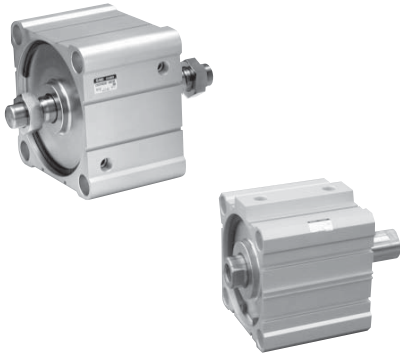

JIS Symbol

Double acting,
Double rod

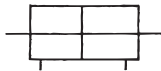

⚠ Precautions

Be sure to read before handling.
For Safety Instructions and Actuator Precautions, refer to pages 7-13-3 to 7-13-6.

⚠ Caution

Snap Ring Installation/Removal

- For installation and removal, use an appropriate pair of pliers (tool for installing a type C snap ring).
- Even if a proper plier (tool for installing type C snap ring) is used, it is likely to inflict damage to a human body or peripheral equipment, as a snap ring may be flown out of the tip of a plier (tool for installing a type C snap ring). Be much careful with the popping of a snap ring. Besides, be certain that a snap ring is placed firmly into the groove of rod cover before supplying air at the time of installment.

Mounting

- When removing a load, be sure to secure the wrench flats of the piston rod on the load side.
- If this is done without securing the piston rod on the load side, be aware that the coupled (screwed-in) portion of the piston rod could become loosened.

Type

Bore size (mm)		125	140	160	180	200
Pneumatic	Mounting	Through-hole/Both ends tapped (Common)				
	Built-in magnet	●	●	●	●	●
	Piping	Screw-in type				
	Rod end male thread	●	●	●	●	●
	Rubber bumper (Standard)	●	●	●	●	●

Specifications

Bore size (mm)	125	140	160	180	200
Type	Pneumatic (Non-lube)				
Fluid	Air				
Proof pressure	1.5 MPa			1.05 MPa	
Maximum operating pressure	1.0 MPa			0.7 MPa	
Ambient and fluid temperature	Without auto switch: -10 to 70°C (No freezing) With auto switch: -10 to 60°C (No freezing)				
Cushion	Rubber bumper (Standard)				
Rod end thread	Female thread				
Rod end thread tolerance	JIS Class 2				
Stroke length tolerance	+1.4 0				
Mounting	Through-hole/Both ends tapped (Common)				
Piston speed	50 to 500 mm/s			20 to 400 mm/s	

Minimum Operating Pressure

(MPa)

Bore size (mm)	125	140	160	180	200
Minimum operating pressure	0.05				

Allowable Kinetic Energy

(J)

Bore size (mm)	125	140	160	180	200
Allowable kinetic energy	7.4	9.8	12.4		

Standard Stroke

Bore size (mm)	Standard stroke
125, 140, 160, 180, 200	10, 20, 30, 40, 50, 75, 100, 125, 150, 175, 200, 250, 300

Manufacture of Intermediate Stroke

Description	Spacer is installed in the standard stroke body.	Exclusive body (-XB10)
Part no.	Refer to "How to Order" for the standard model no. on page 7-6-115.	Suffix "-XB10" to the end of standard model no. on page 7-6-115.
Description	Dealing with the stroke by the 5 mm interval is available by installing spacer with standard stroke cylinder.	Dealing with the stroke by the 1 mm interval by using an exclusive body with the specified stroke.
Stroke range	Bore size	Bore size
	Stroke range	Stroke range
Example	Part no.: CQ2WB160-165DC CQ2WB160-175DC with 10 mm width spacer. B dimension is 266 mm.	Part no.: CQ2WB160-165DC-XB10 Makes 165 stroke tube. B dimension is 256 mm.

Minimum Stroke for Auto Switch Mounting

(mm)

No. of auto switches mounted	D-F7□/F7□V D-J79/J79C D-Y59□/Y69□ D-Y7P/Y7PV	D-A7□, D-A80 D-A73C, D-A80C D-A7□H, D-Z7□ D-Z80, D-A80H	D-F7□W/F7□WV D-J79W D-F7BAL/F7BAVL D-F7NTL/F79F D-F7□W/Y7□WV D-Y7BAL	D-A79W
1 pc.	5	5	10	15
2 pcs.	5	10	15	20

Compact Cylinder: Large Bore Size Type Double Acting, Double Rod Series **CQ2W**

Theoretical Output

(N)

Bore size (mm)	Operating pressure (MPa)		
	0.3	0.5	0.7
125	3376	5627	7878
140	4313	7188	10063
160	5655	9425	13195
180	7257	12095	16933
200	9048	15080	21112



Made to Order Specifications
(For details, refer to page 7-10-1.)

Symbol	Specifications
-XB10	Intermediate stroke (Using exclusive body)
-XC18	NPT finish piping port
-X235	Change of piston rod end for double rod type cylinder
-X271	Fluoro rubber for seals
-X633	Intermediate stroke of double rod type

* -X633 intermediate stroke with 5 mm intervals only

Weight

Without Auto Switch

(kg)

Bore size (mm)	Cylinder stroke (mm)												
	10	20	30	40	50	75	100	125	150	175	200	250	300
125	5.71	6.02	6.34	6.68	7.02	7.87	8.71	9.56	10.41	11.26	12.11	13.81	15.50
140	6.73	7.07	7.43	7.80	8.18	9.13	10.07	11.01	11.96	12.90	13.84	15.73	17.62
160	9.26	9.69	10.12	10.58	11.04	12.18	13.33	14.47	15.62	16.76	17.91	20.20	22.49
180	12.18	12.70	13.23	13.75	14.28	15.59	16.90	18.21	19.52	20.83	22.14	24.76	27.39
200	15.63	16.22	16.80	17.39	17.97	19.44	20.91	22.37	22.84	25.30	26.77	29.70	32.63

Built-in Magnet

(kg)

Bore size (mm)	Cylinder stroke (mm)												
	10	20	30	40	50	75	100	125	150	175	200	250	300
125	5.77	6.08	6.40	6.74	7.08	7.93	8.77	9.62	10.47	11.32	12.17	13.87	15.56
140	6.80	7.14	7.50	7.87	8.25	9.20	10.14	11.08	12.03	12.97	13.91	15.80	17.69
160	9.34	9.77	10.20	10.66	11.12	12.26	13.41	14.55	15.70	16.84	17.99	20.28	22.57
180	12.26	12.78	13.31	13.83	14.36	15.67	16.98	18.29	19.60	20.91	22.22	24.84	27.47
200	15.71	16.30	16.88	17.47	18.05	19.52	20.99	22.45	22.92	25.38	26.85	29.78	32.71

Mounting Bolt for CQ2

Mounting method: Mounting bolt for through-hole mounting style of CQ2WB is available as an option.

Ordering: Add the word "Bolt" in front of the bolts to be used.

Example) Bolt M12 x 100ℓ 4 pcs.

Note 1) To install a through-hole type mounting bolt, make sure to use the flat washer that is provided.

Note 2) Please consult with SMC regarding mounting bolts for strokes that exceed 100 mm. Use the OA screw provided on the cylinder tube to secure the cylinder.

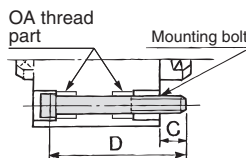

Model	C	D	Mounting bolt	Model	C	D	Mounting bolt
C□Q2WB125/140-10DC	22.9	100	M12 x 100ℓ	C□Q2WB180-10DC	36	125	M18 x 125ℓ
		110	x 110ℓ			135	x 135ℓ
		120	x 120ℓ			145	x 145ℓ
		130	x 130ℓ			155	x 155ℓ
		140	x 140ℓ			165	x 165ℓ
		165	x 165ℓ			190	x 190ℓ
		190	x 190ℓ			215	x 215ℓ
C□Q2WB160-10DC	27.7	110	M14 x 110ℓ	C□Q2WB200-10DC	39	135	M18 x 135ℓ
		120	x 120ℓ			145	x 145ℓ
		130	x 130ℓ			155	x 155ℓ
		140	x 140ℓ			165	x 165ℓ
		150	x 150ℓ			175	x 175ℓ
		175	x 175ℓ			200	x 200ℓ
		200	x 200ℓ			225	x 225ℓ

CUJ

CU

CQS

CQM

CQ2

RQ

MU

D-

-X

20-

Data

Series CQ2W

Additional Weight

(kg)

Bore size (mm)		125	140	160, 180, 200
Rod end male thread	Male thread	0.62	0.62	0.96
	Nut	0.32	0.32	0.52

Calculation: (Example) CDQ2WB125-30DCM

• Cylinder weight: CDQ2WB125-30DC.....6.40 kg

• Option weight: Rod end male thread.....0.94 kg

7.34 kg

Add the weight of auto switches and mounting brackets.

Auto Switch Mounting Bracket Weight

Mounting bracket part no.	Applicable bore size (mm)	Weight (g)
BQ-2	125 to 160	1.5

For auto switch weight, refer to page 7-9-1.

Construction

Double acting, Double rod

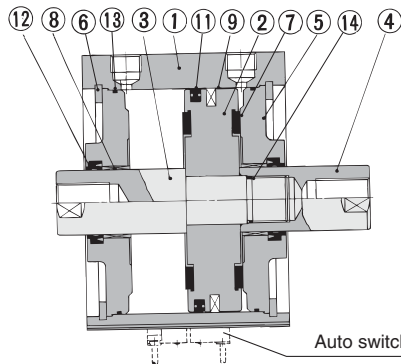

Auto switch (D-A7□/A80)
For only $\phi 125$, $\phi 140$, $\phi 160$

Rod end male thread

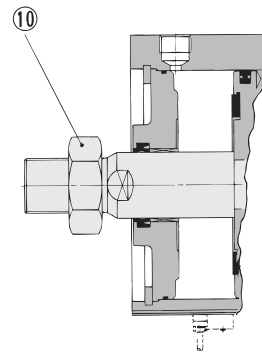

Component Parts

No.	Description	Material	Note
①	Cylinder tube	Aluminum alloy	Hard anodized
②	Piston	Aluminum alloy	Chromated
③	Piston rod A	Carbon steel	Hard chrome plated
④	Piston rod B	Carbon steel	Hard chrome plated
⑤	Rod cover	Cast iron	Nickel plated
⑥	Snap ring	Carbon tool steel	Phosphate coated
⑦	Bumper	Resin	
⑧	Bushing	Lead-bronze casted	For only CDQ2B□
⑨	Magnet	—	Nickel plated
⑩	Rod end nut	Carbon steel	
⑪	Piston seal	NBR	
⑫	Rod seal	NBR	
⑬	Tube gasket	NBR	
⑭	Piston gasket	NBR	

Auto switch mounting bracket: Part number and the proper auto switch mounting position and its mounting height are common as CQ2 series, large bore, double acting, single rod. For details, refer to page 7-6-111 and 114.

Replacement Parts: Seal Kit

Bore size (mm)	Kit no.	Contents
125	CQ2WB125-PS	Set of left nos. ⑪, ⑫, ⑬
140	CQ2WB140-PS	
160	CQ2WB160-PS	
180	CQ2WB180-PS	
200	CQ2WB200-PS	

* Seal kit includes ⑪, ⑫, ⑬. Order the seal kit, based on each bore size.

Rod End Nut

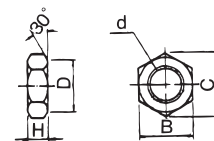

Material: Carbon steel

Part no.	Applicable bore size (mm)	d	H	B	C	D
NT-12	125, 140	M30 x 1.5	18	46	53.1	44
NT-16	160, 180, 200	M36 x 1.5	21	55	63.5	53

Compact Cylinder: Large Bore Size Type Double Acting, Double Rod Series **CQ2W**

Dimensions: $\phi 125, \phi 140, \phi 160$

The dimensions are the same with or without an auto switch.

Basic style (Through-hole): C□Q2WB

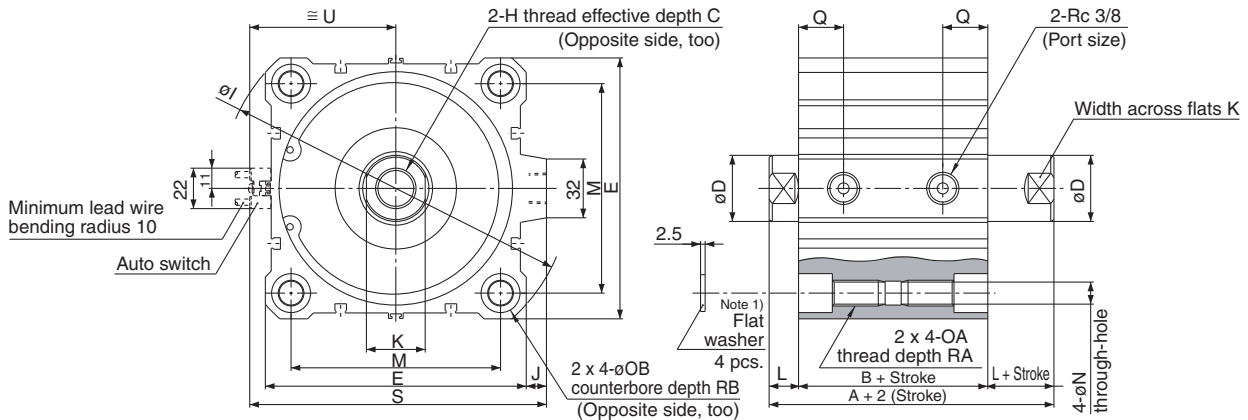

Rod end male thread

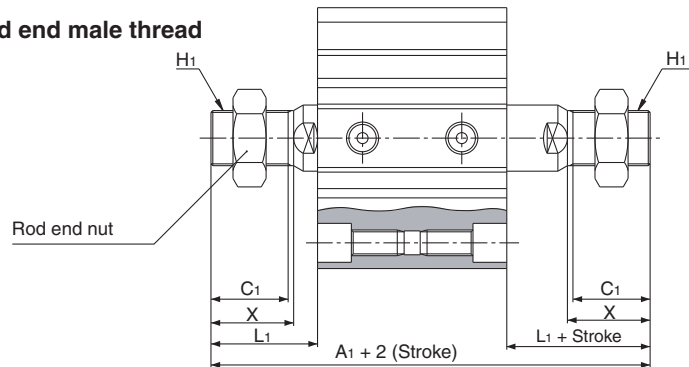

Rod End Male Thread

Bore size (mm)	A1	C1	H1	L1	X
125	199	42	M30 x 1.5	58	45
140	199	42	M30 x 1.5	58	45
160	219	47	M36 x 1.5	64	50

Switches in the above figure are the case for the reed switches D-A73 type and D-A80 type.

Bore size (mm)	Standard stroke range	A	B	C ⁽²⁾	D	E	H	I	J	K	L	M	N	OA	OB	Q	RA	RB	S	U
125	10, 20, 30, 40, 50	115	83	30 (22.5)	36	142	M22 x 2.5	190	11	32	16	114	12.5	M14 x 2	21.2	24.5	25	18.4	162	80
140	75, 100, 125, 150	115	83	30 (22.5)	36	158	M22 x 2.5	210	10	32	16	128	12.5	M14 x 2	21.2	24.5	25	18.4	177	88
160	175, 200, 250, 300	125	91	33 (26.5)	40	178	M24 x 3	238	10	36	17	144	14.5	M16 x 2	24.2	27.5	28	21.2	197	98

Note 1) Be sure to use the attached plain washer for mounting, cylinder with through-holes.

Note 2) () denotes the values of effective length in one side, only for the 10 stroke type.

CUJ

CU

CQS

CQM

CQ2

RQ

MU

D-

-X

20-

Data

Series CQ2W

Dimensions: $\phi 180$, $\phi 200$

The dimensions are the same with or without an auto switch.

$\phi 180$

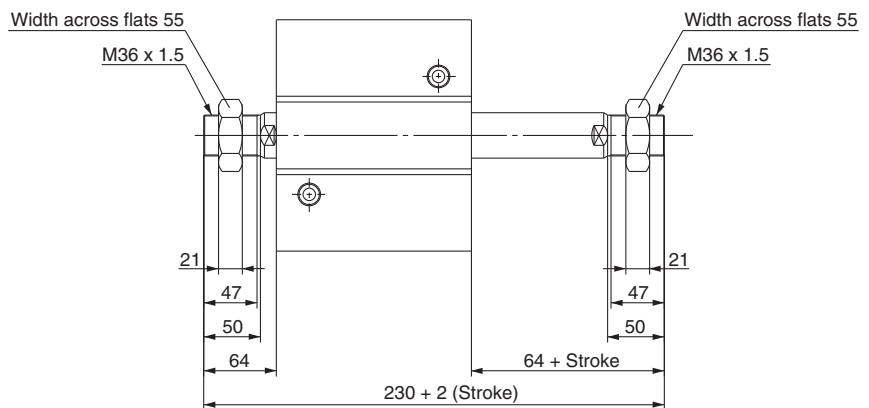
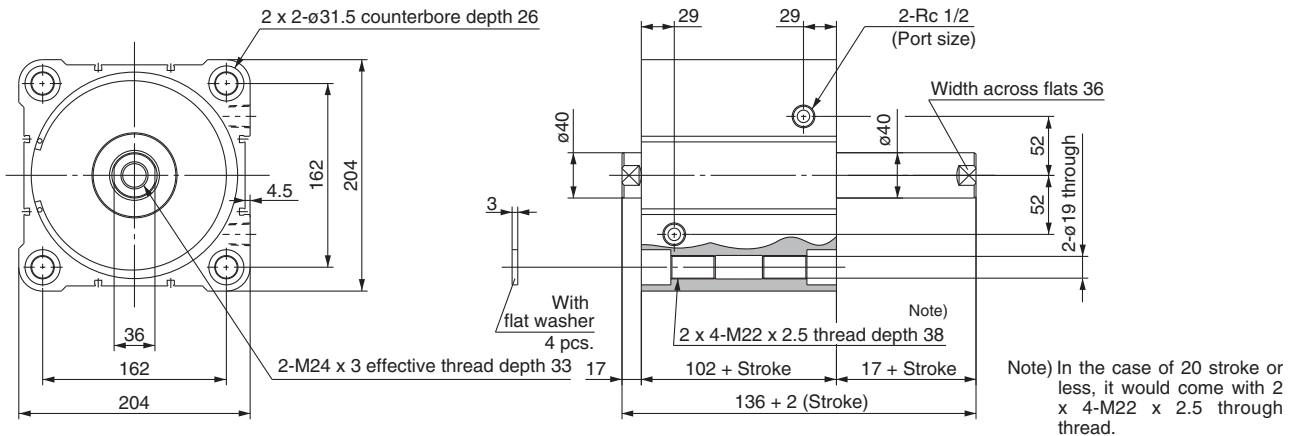

$\phi 200$

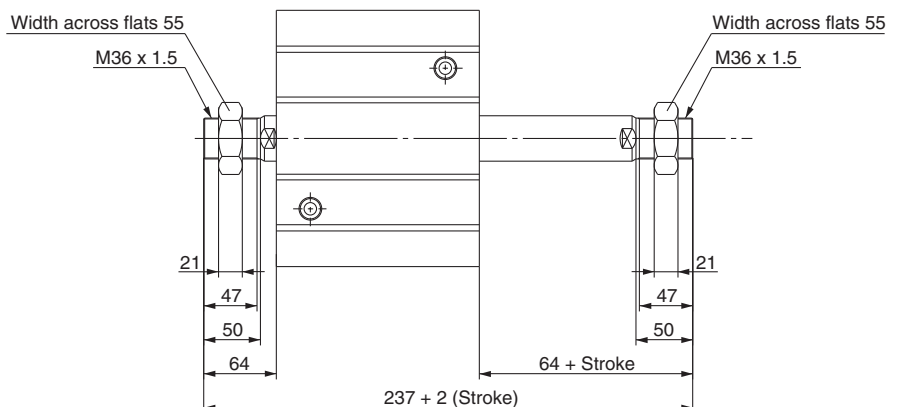
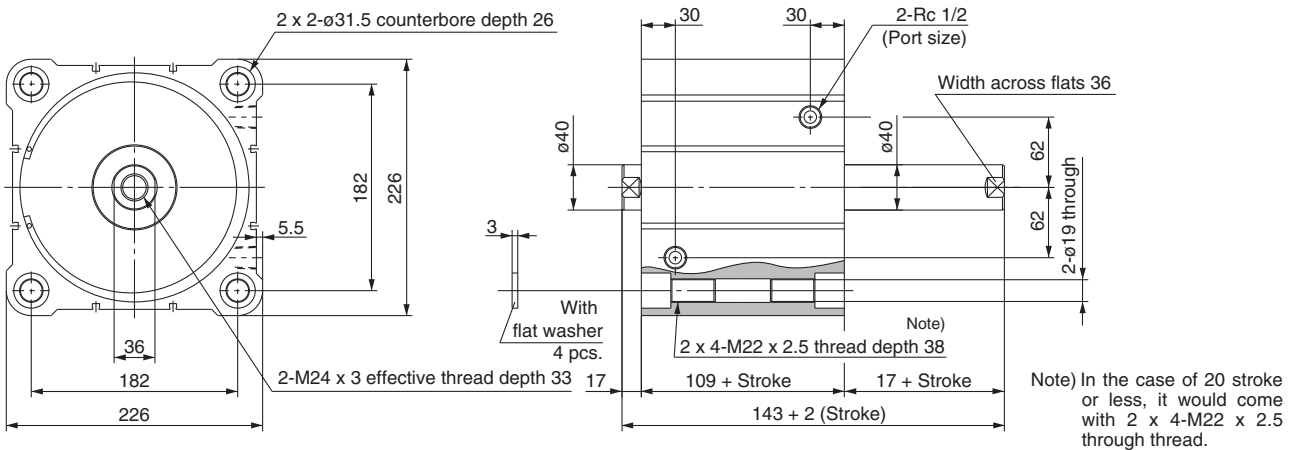



Compact Cylinder: Long Stroke Type

Double Acting, Single Rod

Series CQ2

ø32, ø40, ø50, ø63, ø80, ø100

How to Order

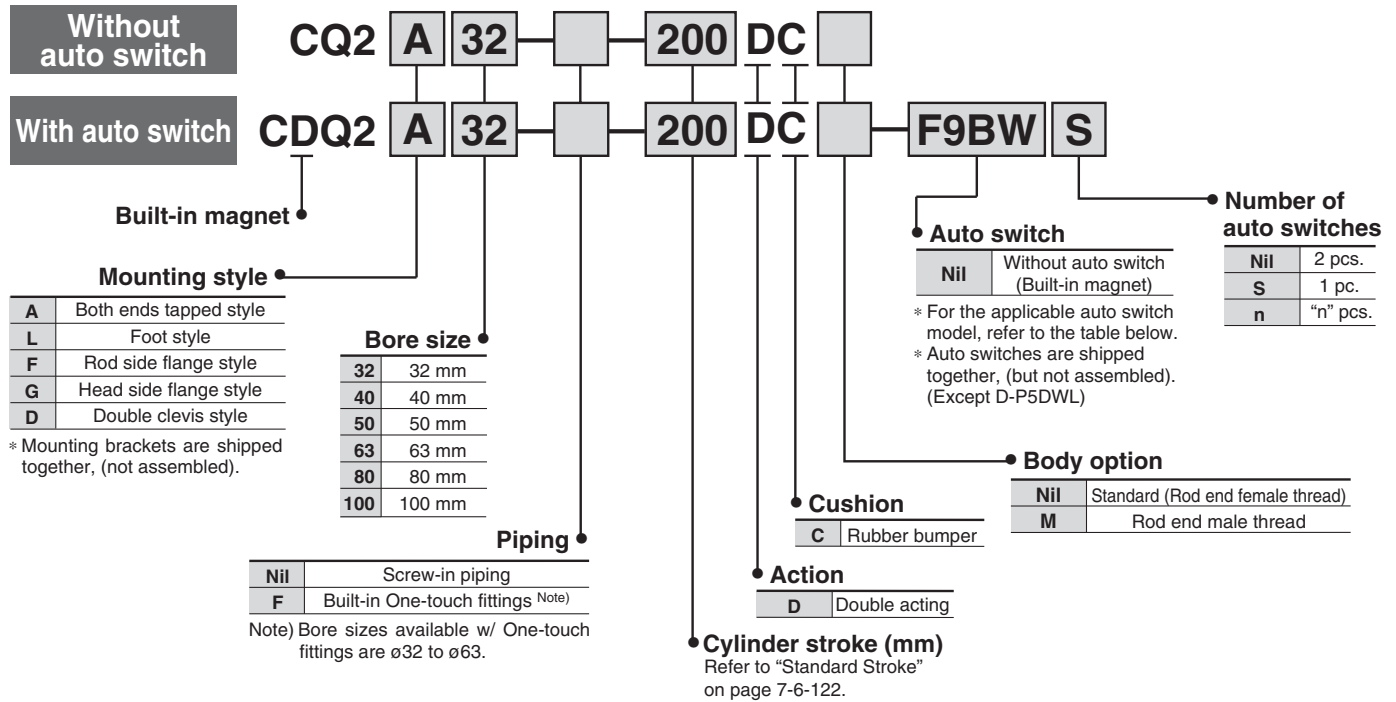

- CUJ
- CU
- CQS
- CQM
- CQ2**
- RQ
- MU
- D-
- X
- 20-
- Data

Applicable Auto Switch/Refer to page 7-9-1 for further information on auto switches.

Type	Special function	Electrical entry	Indicator/light	Wiring (Output)	Load voltage		Rail mounting		Direct mounting		Lead wire length (m) *				Pre-wire connector	Applicable load				
					DC	AC	Perpendicular	In-line	Perpendicular	In-line	0.5 (Nil)	3 (L)	5 (Z)	None (N)		IC circuit	Relay, PLC			
Reed switch	—	Grommet	Yes	3-wire (NPN equivalent)	—	5 V	—	—	A76H	A96V	A96	●	●	—	—	—	IC circuit	—		
						—	200 V	A72	A72H	—	—	●	●	—	—	—	—	—	—	—
	Connector	2-wire		24 V	12 V	—	100 V	A73	A73H	—	—	A93V	A93	●	●	—	—	—	—	
					12 V	—	A73C	—	—	—	●	●	●	●	—	—	—	—	—	—
Diagnostic indication (2-color indication)	Grommet	—	—	—	—	—	A79W	—	—	—	—	●	●	—	—	—	—	—		
Solid state switch	—	Grommet	Yes	3-wire (NPN)	5 V, 12 V	—	F7NV	F79	M9NV	M9N	●	●	○	—	○	—	IC circuit	Relay, PLC		
							F7PV	F7P	M9PV	M9P	●	●	○	—	○	—	—		—	
	Connector	2-wire		12 V	F7BV	J79	M9BV	M9B	●	●	○	—	○	—	—	—	—			
					J79C	—	—	—	●	●	●	●	—	—	—	—				
	Diagnostic indication (2-color indication)	Grommet		3-wire (NPN)	5 V, 12 V	—	F7NVV	F79W	F9NVV	F9NW	●	●	○	—	○	—	—		IC circuit	
							—	F7PW	F9PWV	F9PW	●	●	○	—	○	—	—		—	
	Water resistant (2-color indication)	Grommet		2-wire	24 V	12 V	—	F7BWW	J79W	F9BWW	F9BW	●	●	○	—	○	—		—	—
								—	F7BA	—	F9BA	—	●	●	○	—	○		—	—
With diagnostic output (2-color indication)	Grommet	4-wire (NPN)	5 V, 12 V	—	—	—	F79F	—	—	●	●	○	—	○	—	IC circuit				
						—	P5DW	—	—	—	●	●	—	○	—	—	—			
Magnetic field resistant (2-color indication)	Grommet	2-wire	—	—	—	—	—	—	—	—	●	●	—	○	—	—	—			

* Lead wire length symbols: 0.5 m.....Nil (Example) A73C
 3 m.....L (Example) A73CL
 5 m.....Z (Example) A73CZ
 None.....N (Example) A73CN

* Solid state switches marked with "○" are produced upon receipt of order.

- D-P5DWL type is available from ø40 up to ø100 only.
- There are other applicable auto switches other than the listed above. For details, refer to page 7-6-23.
- For details about auto switches with pre-wire connector, refer to page 7-9-36.



Series CQ2



JIS Symbol
Double acting,
Single rod

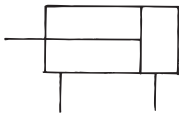

Made to Order Specifications (For details, refer to page 7-10-1.)

Symbol	Specifications
-XB10	Intermediate stroke (Using exclusive body)
-XC4	With heavy duty scraper
-XC6	Piston rod and rod end nut made of stainless steel
-XC18	NPT finish piping port
-X271	Fluoro rubber for seals

⚠ Precautions

Be sure to read before handling.
For Safety Instructions and Actuator Precautions, refer to pages 7-13-3 to 7-13-6.

⚠ Caution

Snap Ring Installation/Removal

- For installation and removal, use an appropriate pair of pliers (tool for installing a type C snap ring).
- Even if a proper plier (tool for installing type C snap ring) is used, it is likely to inflict damage to a human body or peripheral equipment, as a snap ring may be flown out of the tip of a plier (tool for installing a type C snap ring). Be much careful with the popping of a snap ring. Besides, be certain that a snap ring is placed firmly into the groove of rod cover before supplying air at the time of installment.

Type

Bore size (mm)		32	40	50	63	80	100	
Pneumatic	Built-in magnet	●	●	●	●	●	●	
	Piping	Screw-in type type	Rc 1/8	Rc 1/8	Rc 1/4	Rc 1/4	Rc 3/8	Rc 3/8
		Built-in One-touch fittings	ø6/4	ø6/4	ø8/6	ø8/6	—	—
	Rod end male thread	●	●	●	●	●	●	

Specifications

Type	Pneumatic (Non-lube)
Fluid	Air
Proof pressure	1.5 MPa
Maximum operating pressure	1.0 MPa
Ambient and fluid temperature	Without auto switch: -10 to 70°C (No freezing) With auto switch: -10 to 60°C (No freezing)
Cushion	Rubber bumper (Standard equipment)
Rod end thread	Female thread
Rod end thread tolerance	JIS Class 2
Stroke length tolerance	+1.4 0
Mounting	Both ends tapped style
Piston speed	50 to 500 mm/s

Minimum Operating Pressure

(MPa)

Bore size (mm)	32	40	50	63	80	100
Minimum operating pressure	0.05					

Allowable Kinetic Energy

(J)

Bore size (mm)	12	16	20	25	32	40	50	63	80	100
Allowable kinetic energy	0.043	0.075	0.11	0.18	0.29	0.52	0.91	1.54	2.71	4.54

Standard Stroke

Bore size (mm)	Standard stroke
32, 40, 50, 63, 80, 100	125, 150, 175, 200, 250, 300

Manufacture of Intermediate Stroke

Description	Spacer is installed in the standard stroke body.	Exclusive body (-XB10)
Part no.	Refer to "How to Order" for the standard model no. on page 7-6-121.	Suffix "-XB10" to the end of standard model no. on page 7-6-121.
Description	Dealing with the stroke by the 1 mm interval is available by installing spacer with standard stroke cylinder.	Dealing with the stroke by the 1 mm interval by using an exclusive body with the specified stroke.
Stroke range	Bore size	Bore size
	Stroke range	Stroke range
Example	Part no.: CQ2A50-166DC CQ2A50-175DC with 9 mm width spacer. B dimension is 230.5 mm.	Part no.: CQ2B50-166DC-XB10 Makes 166 stroke tube. B dimension is 221.5 mm.

Compact Cylinder: Long Stroke Type Double Acting, Single Rod Series CQ2

Copper-free (For CRT manufacturing process)

20 — CQ2A Bore size — Stroke DC(M)
 • Copper-free • $\phi 32, \phi 40, \phi 50, \phi 63, \phi 80, \phi 100$

To prevent the influence of copper ions or halogen ions during CRT manufacturing processes, copper and fluorine materials are not used in the component parts.

Specifications

Action	Double acting, Single rod
Bore size (mm)	32, 40, 50, 63, 80, 100
Proof pressure	1.5 MPa
Max. operating pressure	1.0 MPa
Rubber bumper	With (Standard equipment)
Piping	Screw-in piping
Piston speed	50 to 500 mm/S
Mounting	Both ends tapped style
Auto switch	Mountable

Allowable Lateral Load at Rod End

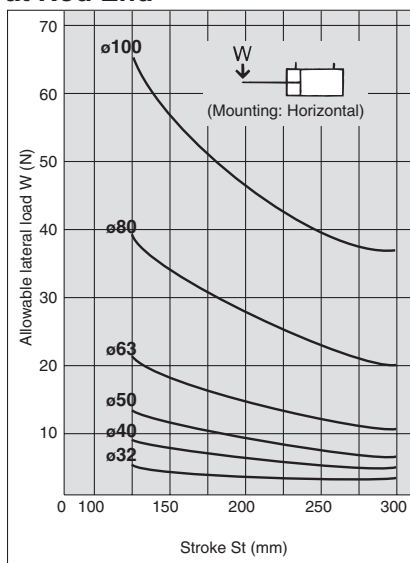

Mounting Bracket Part No.

Bore size (mm)	Foot (2)	Flange	Double clevis
32	CQ-L032	CQ-F032	CQ-D032
40	CQ-L040	CQ-F040	CQ-D040
50	CQ-L050	CQ-F050	CQ-D050
63	CQ-L063	CQ-F063	CQ-D063
80	CQ-L080	CQ-F080	CQ-D080
100	CQ-L100	CQ-F100	CQ-D100

Note 2) When ordering foot bracket, order 2 pieces per cylinder.
 Note 3) Parts belonging to each bracket are as follows.
 Foot or Flange style: Body mounting bolt, Double clevis/Clevis pin, Body mounting bolt, C shape snap ring for axis.



Theoretical Output

Bore size (mm)	Operating direction	Operating pressure (MPa)			Bore size (mm)	Operating direction	Operating pressure (MPa)		
		0.3	0.5	0.7			0.3	0.5	0.7
32	IN	181	302	422	63	IN	841	1402	1962
	OUT	241	402	563		OUT	935	1559	2182
40	IN	317	528	739	80	IN	1361	2268	3175
	OUT	377	628	880		OUT	1508	2513	3519
50	IN	495	825	1155	100	IN	2144	3574	5003
	OUT	589	982	1374		OUT	2356	3927	5498

Weight

Without Auto Switch (g)

Bore size (mm)	Cylinder stroke (mm)					
	125	150	175	200	250	300
32	754	859	965	1070	1279	1490
40	945	1063	1180	1298	1535	1770
50	1469	1650	1832	2007	2376	2739
63	1810	2018	2227	2438	2851	3268
80	3120	3456	3793	4127	4801	5474
100	4956	5374	5790	6020	7042	7875

Built-in Magnet (g)

Bore size (mm)	Cylinder stroke (mm)					
	125	150	175	200	250	300
32	763	868	974	1079	1288	1499
40	959	1077	1194	1312	1549	1784
50	1484	1665	1847	2022	2391	2754
63	1834	2042	2251	2462	2875	3292
80	3144	3480	3817	4151	4825	5498
100	4994	5412	5828	6058	7080	7913

Additional Weight (g)

Bore size (mm)		32	40	50	63	80	100
Rod end male thread	Male thread	26	27	53	53	120	175
	Nut	17	17	32	32	49	116
Foot style (Including mounting bolt)		147	159	253	356	685	1123
Rod side flange style (Including mounting bolt)		165	198	348	534	1017	1309
Head side flange style (Including mounting bolt)		165	198	348	534	1017	1309
Double clevis style (Including pin, snap ring, bolt)		151	196	393	554	1109	1887

Calculation: (Example) CQ2D32-200DCM
 • Cylinder weight: CQ2A32-200DC..... 1070 g
 • Option weight: Rod end male thread..... 43 g
 Double clevis style..... 151 g
 1264 g

Add the weight of auto switches and mounting brackets when auto switches are mounted.

Auto Switch Mounting Bracket Weight

Mounting bracket part no.	Applicable bore size(mm)	Weight (g)
BQ-2	32 to 100	1.5

For the auto switch weight, refer to page 7-9-1.

CUJ

CU

CQS

CQM

CQ2

RQ

MU

D-

-X

20-

Data

Series CQ2

Construction

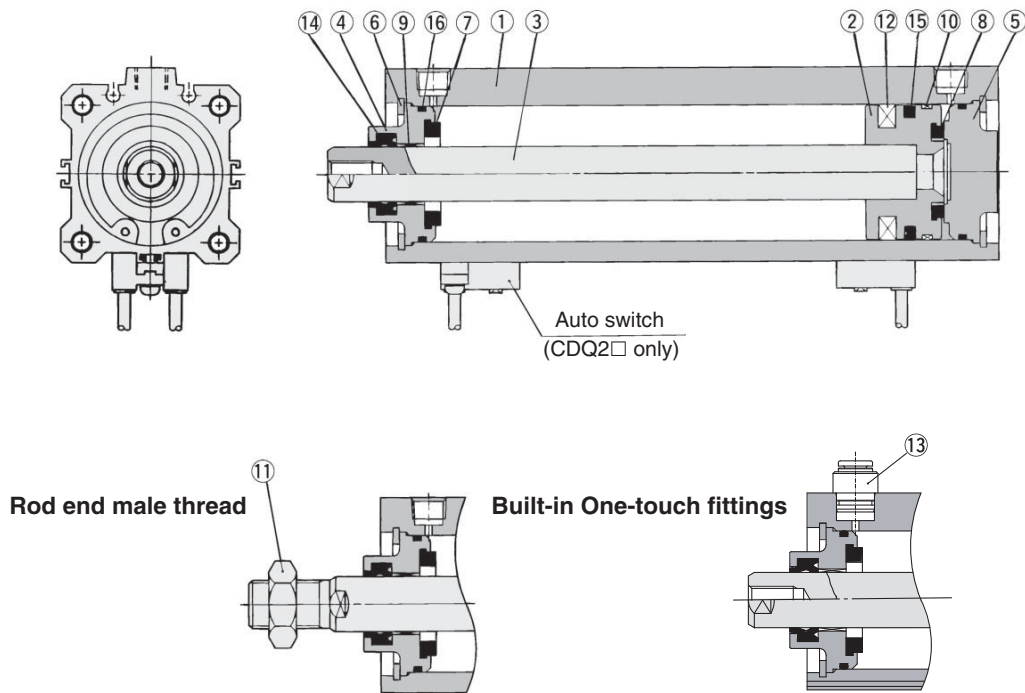

Component Parts

No.	Description	Material	Note
①	Cylinder tube	Aluminum alloy	Hard anodized
②	Piston	Aluminum alloy	Chromated
③	Piston rod	Carbon steel	Hard chrome plated
④	Collar	Aluminum alloy	Anodized
⑤	Bottom plate	Aluminum alloy	Anodized
⑥	Snap ring	Carbon tool steel	Phosphate coated
⑦	Bumper A	Urethane	
⑧	Bumper B	Urethane	
⑨	Bushing	Phosphor bronze alloy	
⑩	Wear ring	Resin	
⑪	Rod end nut	Carbon steel	Nickel plated
⑫	Magnet	—	For only CDQ2□A
⑬	One-touch fitting	—	ø32 to ø63
⑭*	Rod seal	NBR	
⑮*	Piston seal	NBR	
⑯*	Tube gasket	NBR	

Replacement Parts: Seal Kit

Bore size (mm)	Kit no.	Contents
32	CQ2A32-L-PS	Set of left nos. ⑭, ⑮, ⑯
40	CQ2A40-L-PS	
50	CQ2A50-L-PS	
63	CQ2A63-L-PS	
80	CQ2A80-L-PS	
100	CQ2A100-L-PS	

* Seal kit includes ⑭, ⑮, ⑯. Order the seal kit, based on each bore size.

Series CQ2

Dimensions: $\varnothing 32$ to $\varnothing 50$

The dimensions are the same with or without an auto switch.

Both ends tapped style: C□Q2A

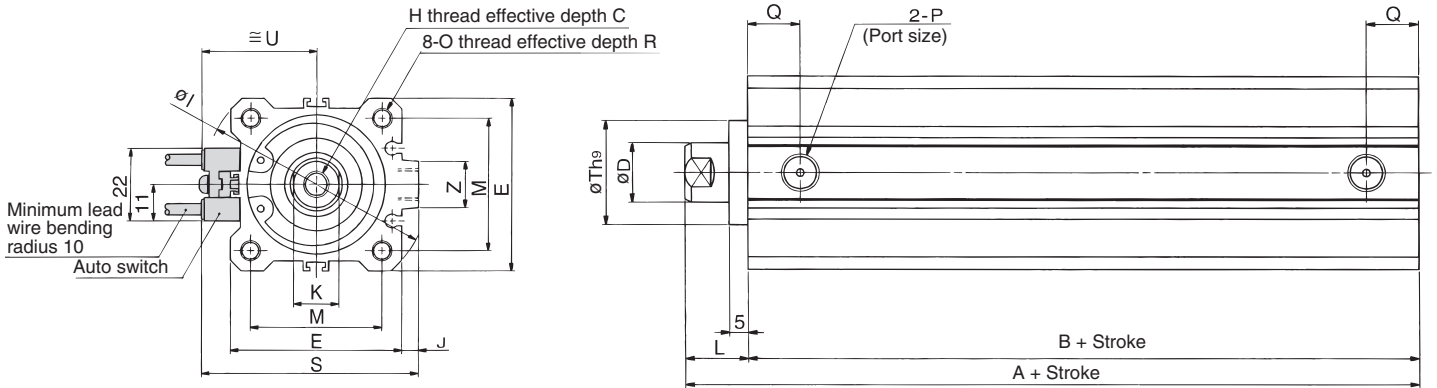

Rod end male thread

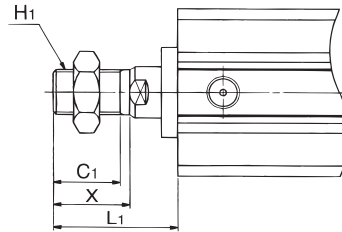

Rod End Male Thread

Bore size (mm)	C1	H1	L1	X
32	20.5	M14 x 1.5	38.5	23.5
40	20.5	M14 x 1.5	38.5	23.5
50	26	M18 x 1.5	43.5	28.5

Auto switch shown above is D-A73 and D-A80. For the auto switch mounting position and its mounting height, refer to page 7-6-130.

Dimensions of built-in One-touch fitting are equivalent to Series CQ2, double acting, single rod. Refer to page 7-6-16.

Both Ends Tapped Style

Bore size (mm)	Stroke range (mm)	A	B	C	D	E	H	I	J	K	L	M	O	P	Q	R	S	Th9	U	Z
32	125 to 200 250, 300	62.5	45.5	13	16	45	M8 x 1.25	60	4.5	14	17	34	M6 x 1.0	Rc 1/8	12.5	10	58.5	22 ⁰ _{-0.052}	31.5	14
40		72	55	13	16	52	M8 x 1.25	69	5	14	17	40	M6 x 1.0	Rc 1/8	14	10	66	28 ⁰ _{-0.052}	35	14
50		73.5	55.5	15	20	64	M10 x 1.5	86	7	17	18	50	M8 x 1.25	Rc 1/4	14	14	80	35 ⁰ _{-0.062}	41	19

Note 1) For 125 to 200 stroke, strokes are by the 25 mm interval.
Note 2) For calculation on the longitudinal dimension of the intermediate strokes, refer to page 7-6-122.

Foot style: C□Q2L

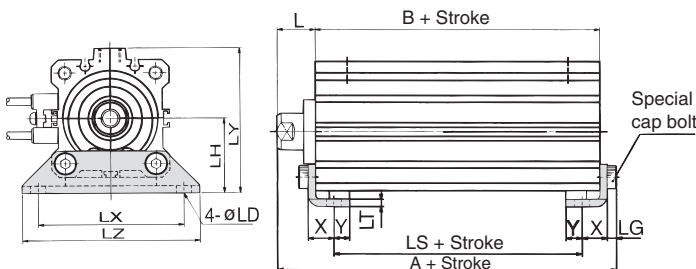

Foot Style

Bore size (mm)	A	B	L	L1	LD	LG	LH	LS	LT	LX	LY	LZ	X	Y
32	69.7	45.5	17	38.5	6.6	4	30	29.5	3.2	57	57	71	11.2	5.8
40	79.2	55	17	38.5	6.6	4	33	39	3.2	64	64	78	11.2	7
50	81.7	55.5	18	43.5	9	5	39	32.5	3.2	79	78	95	14.7	8

Foot bracket material: Carbon steel

* For details about the rod end nut and accessory brackets, refer to page 7-6-20.

Rod end male thread

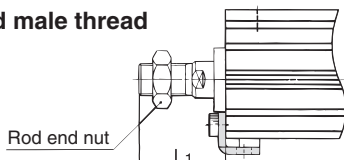

Compact Cylinder: Long Stroke Type Double Acting, Single Rod Series CQ2

Rod side flange style: C□Q2F

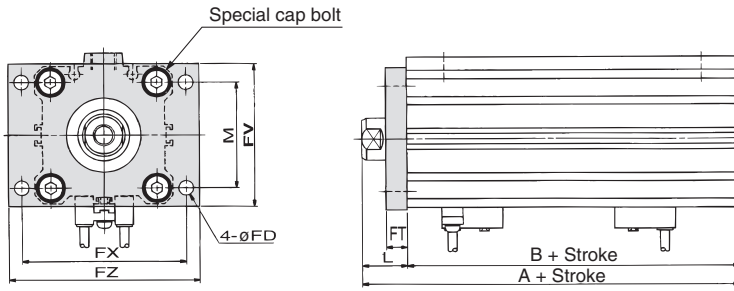

Rod Side Flange Style

Bore size (mm)	A	B	FD	FT	FV	FX	FZ	L	L1	M
32	62.5	45.5	5.5	8	48	56	65	17	38.5	34
40	72	55	5.5	8	54	62	72	17	38.5	40
50	73.5	55.5	6.6	9	67	76	89	18	43.5	50

Flange bracket material: Carbon steel

CUJ

CU

CQS

CQM

CQ2

RQ

MU

D-

-X

20-

Data

Rod end male thread

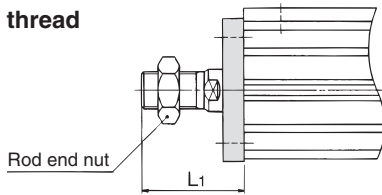

Head side side flange style: C□Q2G

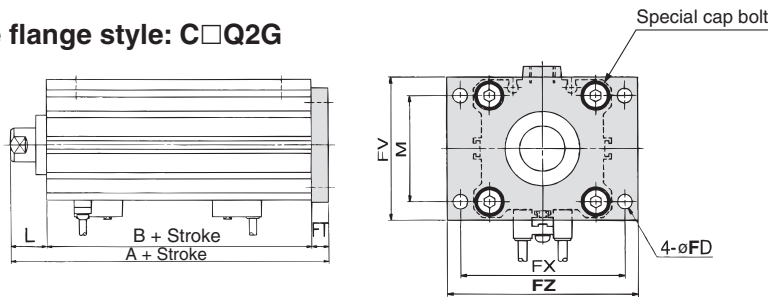

Head Side Flange Style

Bore size (mm)	A
32	70.5
40	80
50	82.5

Flange bracket material: Carbon steel
* Dimensions except A are the same as rod side flange style.

Rod end male thread

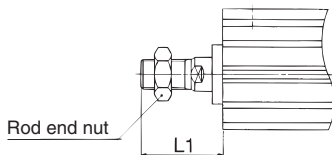

Double clevis style: C□Q2D

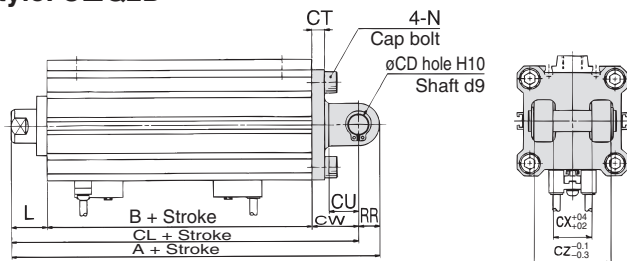

Double Clevis Style

Bore size (mm)	A	B	CD	CL	CT	CU	CW	CX	CZ
32	92.5	45.5	10	82.5	5	14	20	18	36
40	104	55	10	94	6	14	22	18	36
50	115.5	55.5	14	101.5	7	20	28	22	44

Bore size (mm)	L	L1	N	RR
32	17	38.5	M6 x 1.0	10
40	17	38.5	M6 x 1.0	10
50	18	43.5	M8 x 1.25	14

Double clevis bracket material: Cast iron

* For details about the rod end nut and accessory brackets, refer to page 7-6-20.

** Clevis pin and snap ring are shipped together.

Rod end male thread

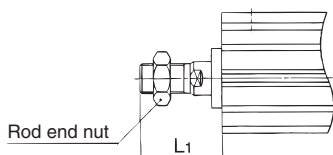

Series CQ2

Dimensions: $\phi 63$ to $\phi 100$

The dimensions are the same with or without an auto switch.

Both ends tapped style: Series C□Q2A

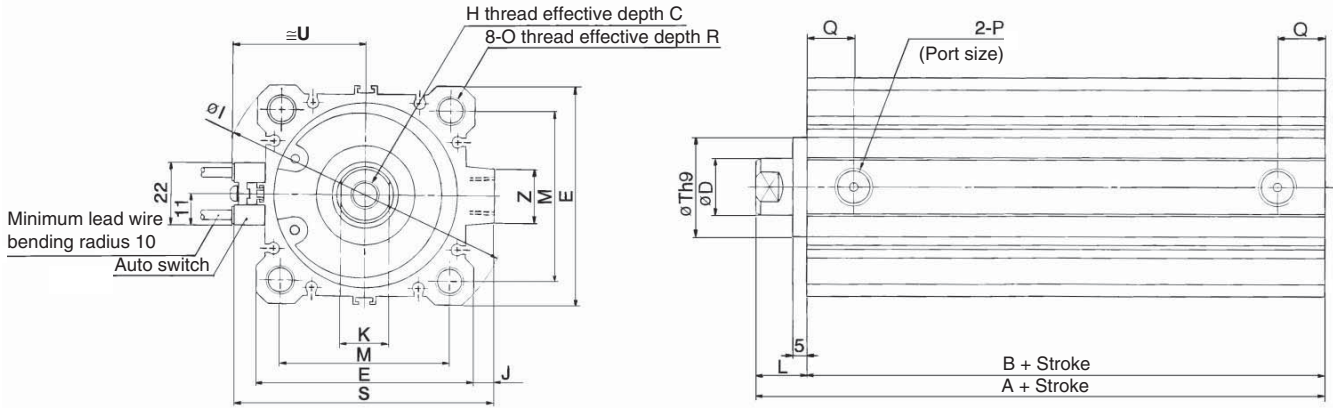

Rod end male thread

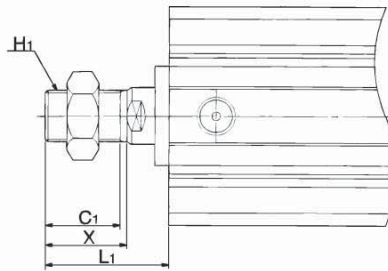

Rod End Male Thread

Bore size (mm)	C1	H1	L1	X
63	26	M18 x 1.5	43.5	28.5
80	32.5	M22 x 1.5	53.5	35.5
100	32.5	M26 x 1.5	53.5	35.5

Auto switch shown above is D-A73 and D-A80. For the auto switch mounting position and its mounting height, refer to page 7-6-130.

Dimensions of built-in One-touch fitting are equivalent to Series CQ2, double acting, single rod. Refer to page 7-6-18.

Both Ends Tapped Style

Bore size (mm)	Stroke range (mm)	A	B	C	D	E	H	I	J	K	L	M	O	P	Q	R	S	Th9	U	Z
63	(1) 125 to 200 250, 300	75	57	15	20	77	M10 x 1.5	103	7	17	18	60	M10 x 1.5	Rc 1/4	16.5	18	93	35 ⁰ _{-0.062}	47.5	19
80		86	66	21	25	98	M16 x 2.0	132	6	22	20	77	M12 x 1.75	Rc 3/8	19	22	112.5	43 ⁰ _{-0.062}	57.5	26
100		97.5	75.5	27	30	117	M20 x 2.5	156	6.5	27	22	94	M12 x 1.75	Rc 3/8	23	22	132.5	59 ⁰ _{-0.074}	67.5	26

Note 1) For 125 to 200 stroke, strokes are by the 25 mm interval.
Note 2) For calculation on the longitudinal dimension of the intermediate strokes, refer to page 7-6-3.

Foot style: C□Q2L

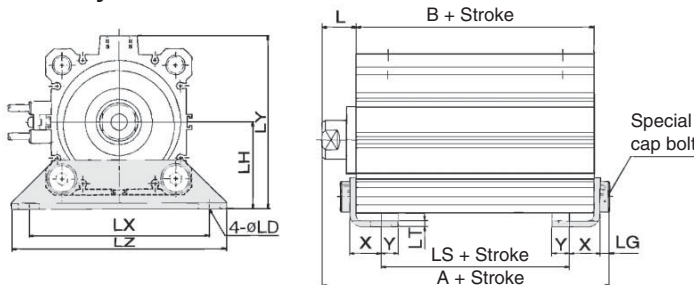

Foot Style

Bore size (mm)	A	B	L	L1	LD	LG	LH	LS	LT	LX	LY	LZ	X	Y
63	83.2	57	18	43.5	11	5	46	31	3.2	95	91.5	113	16.2	9
80	97.5	66	20	53.5	13	7	59	36	4.5	118	114	140	19.5	11
100	110.5	75.5	22	53.5	13	7	71	41.5	6	137	136	162	23	12.5

Foot bracket material: Carbon steel
* For details about the rod end nut and accessory brackets, refer to page 7-6-20.

Rod end male thread

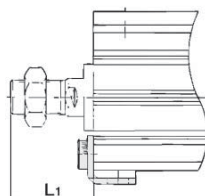

Compact Cylinder: Long Stroke Type Double Acting, Single Rod Series CQ2

Rod side flange style: C□Q2F

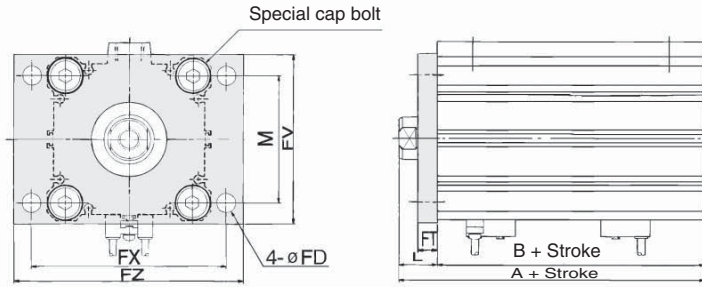

Rod Side Flange Style

Bore size (mm)	A	B	FD	FT	FV	FX	FZ	L	L1	M
63	75	57	9	9	80	92	108	18	43.5	60
80	86	66	11	11	99	116	134	20	53.5	77
100	97.5	75.5	11	11	117	136	154	22	53.5	94

Flange bracket material: Carbon steel

Rod end male thread

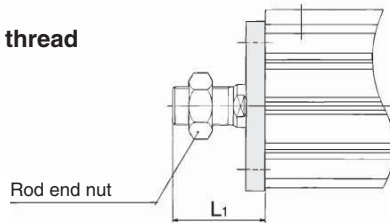

Head side flange style: C□Q2G

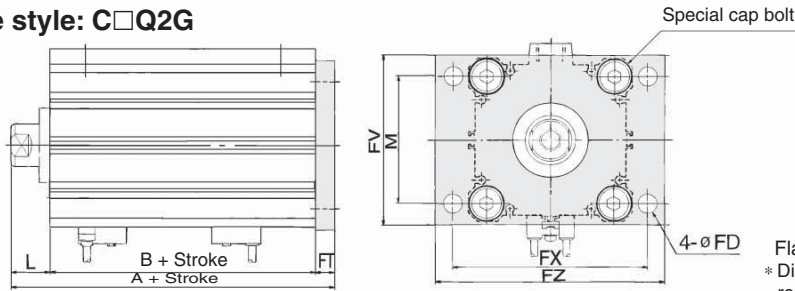

Head Side Flange Style

Bore size (mm)	A
63	84
80	97
100	108.5

Flange bracket material: Carbon steel
* Dimensions except A are the same as rod side flange style.

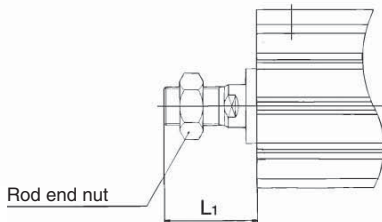

Rod end male thread

Double clevis style: C□Q2D

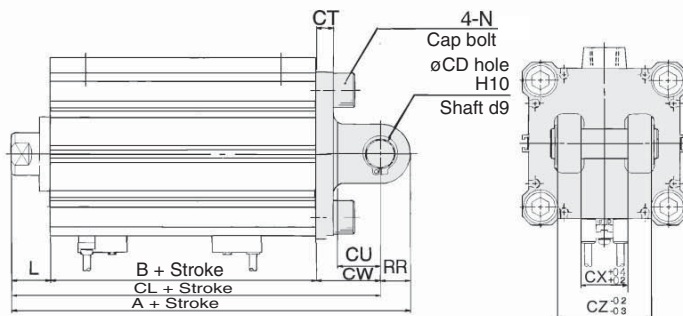

Double Clevis Style

Bore size (mm)	A	B	CD	CL	CT	CU	CW	CX	CZ
63	119	57	14	105	8	20	30	22	44
80	142	66	18	124	10	27	38	28	56
100	164.5	75.5	22	142.5	13	31	45	32	64

Bore size (mm)	L	L1	N	RR
63	18	43.5	M10 x 1.5	14
80	20	53.5	M12 x 1.75	18
100	22	53.5	M12 x 1.75	22

Double clevis bracket material: Cast iron

* For details about the rod end nut and accessory brackets, refer to page 7-6-20.

** Clevis pin and snap ring are attached.

Rod end male thread

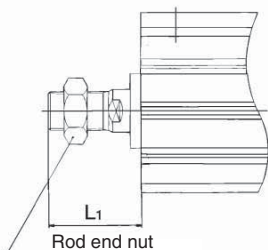

Rod end nut

Series CQ2

Proper Auto Switch Mounting Position (Detection at stroke end) and Its Mounting Height

D-A7□
D-A80

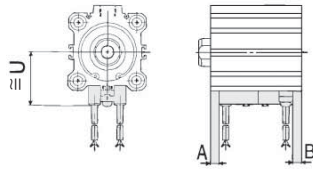

D-A73C
D-A80C
D-J79C

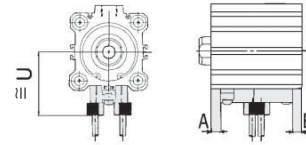

D-A7□H D-F7□W
D-A80H D-J79W
D-F7□ D-F79F
D-J79 D-F7NTL
D-F7BAL

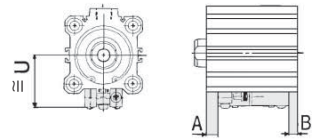

D-A79W
D-F7□WV
D-F7□V
D-F7BAVL

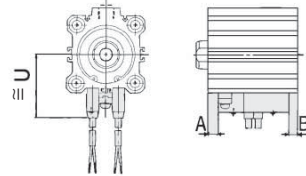

D-F9BAL

D-A9□
D-M9□
D-F9□W

D-A9□V
D-M9□V
D-F9□WV

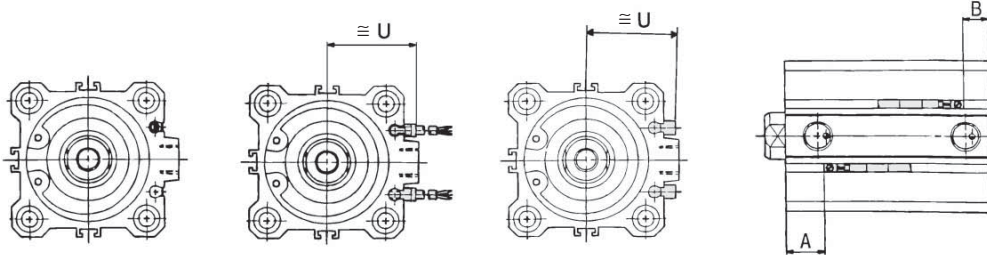

ø40 to ø100

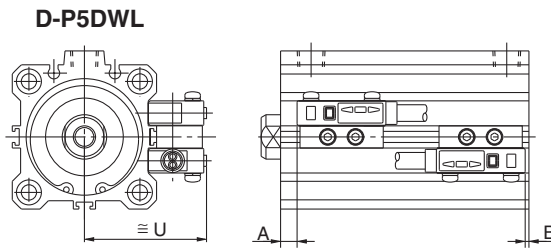

Proper Auto Switch Mounting Position

Bore size (mm)	D-A7□ D-A80		D-A7□H D-A80H D-A73C D-A80C D-F7□ D-F79F D-J79 D-F7□V D-J79C D-F7□W D-J79W D-F7□WV D-F7BAL D-F7BAVL				D-A79W		D-A9□ D-A9□V		D-M9□ D-M9□V D-F9□W D-F9□WV		D-F9BAL		D-P5DWL	
	A	B	A	B	A	B	A	B	A	B	A	B	A	B	A	B
32	9.5	17.5	10	18	7	15	8.5	16.5	12.5	20.5	11.5	19.5	—	—	—	—
40	13	23.5	13.5	24	10.5	21	12	22.5	16	26.5	15	25.5	9	19.5	—	—
50	11	24	11.5	24.5	8.5	21.5	10	23	14	27	13	26	7	20	—	—
63	13.5	25.5	14	26	11	23	12.5	24.5	16.5	28.5	15.5	27.5	9.5	21.5	—	—
80	16.5	31.5	17	32	14	29	15.5	30.5	19.5	34.5	18.5	33.5	12.5	29.5	—	—
100	19.5	38	20	38.5	17	35.5	18.5	37	22.5	41	21.5	40	15.5	34	—	—

Auto Switch Mounting Height

(mm)

D-A7□ D-A80	D-A73C D-A80C	D-F7□V D-F7□WV D-F7BAVL	D-J79C	D-A79W	D-A9□V	D-M9□V D-F9□WV	D-F9BAL	D-P5DWL
U	U	U	U	U	U	U	U	U
31.5	32.5	38.5	35	38	34	27	29	26.5
35	36	42	38.5	41.5	37.5	30.5	32.5	30
41	42	48	44.5	47.5	43.5	36.5	38.5	36
47.5	48.5	54.5	51	54	50	40	42	39.5
57.5	58.5	64.5	61	64	60	50	52	49.5
67.5	68.5	74.5	71	74	70	60	62	59.5

Compact Cylinder: Long Stroke Type Double Acting, Single Rod **Series CQ2**

Auto Switch Mounting Bracket Part No.

Bore size (mm)	Mounting bracket part no.	Note	Applicable auto switch	
			Reed switch	Solid state switch
32, 40 50, 63 80, 100	BQ-2	<ul style="list-style-type: none"> Switch mounting screw (M3 x 0.5 x 10ϕ) Switch spacer Switch mounting nut 	D-A7□/A80 D-A73C/A80C D-A7□H/A80H D-A79W	D-F7□/J79 D-F7□V D-J79C D-F7□W/J79W D-F7□WV D-F7BAL/F7BAVL D-F79F, D-F7NTL
40 to 100	BQP1-050	<ul style="list-style-type: none"> Switch mounting bracket Switch mounting nut Hexagon socket head cap bolt (M3 x 0.5 x 14ϕ spring washer 2 pcs.) Round head Phillips screw (M3 x 0.5 x 16ϕ spring washer 2 pcs.) 	—	D-P5DWL



* Mounting screws set made of stainless steel
 The set of stainless steel mounting screws (with nuts) described below is available and can be used depending on the operating environment.
 (Since the spacer is not included, order it separately.)
 BBA2: For D-A7/A8/F7/J7
 "D-F7BAL/F7BAVL" switch is set on the cylinder with the stainless steel screws above when shipped.
 When only a switch is shipped independently, "BBA2" screws are attached.

CUJ

CU

CQS

CQM

CQ2

RQ

MU

D-

-X

20-

Data



Compact Cylinder: Anti-lateral Load Type Double Acting, Single Rod

Series CQ2

ø32, ø40, ø50, ø63, ø80, ø100

How to Order

Without auto switch
CQ2

With auto switch
CDQ2

Mounting style

B	Through-hole (Standard)
A	Both ends tapped style
L	Foot style
F	Rod side flange style
G	Head side flange style
D	Double clevis style

Cushion

S	Anti-lateral load type
---	------------------------

Cylinder stroke (mm)
Refer to "Standard Stroke" on page 7-6-133.

Bore size

32	32 mm
40	40 mm
50	50 mm
63	63 mm
80	80 mm
100	100 mm

Action

D	Double acting
---	---------------

Auto switch

Nil	Without auto switch (Built-in magnet)
S	1 pc.
n	"n" pcs.

Number of auto switches

Body option 2

Nil	Standard (Rod end female thread)
M	Rod end male thread

Body option 1

Nil	Standard
F	With boss in head side

Auto switch

Nil	Without auto switch (Built-in magnet)
S	1 pc.
n	"n" pcs.

* For the applicable auto switch model, refer to the table below.
* Auto switches are shipped together, (but not assembled). (Except D-P5DWL)

Applicable Auto Switch/Refer to page 7-9-1 for further information on auto switches.

Type	Special function	Electrical entry	Indicator light	Wiring (Output)	Load voltage		Rail mounting		Direct mounting		Lead wire length (m) *				Pre-wire connector	Applicable load		
					DC	AC	Perpendicular	In-line	Perpendicular	In-line	0.5 (Nil)	3 (L)	5 (Z)	None (N)				
Reed switch	—	Grommet	Yes	3-wire (NPN equivalent)	—	5 V	—	A76H	A96V	A96	●	●	—	—	—	IC circuit	—	
				—	—	200 V	A72	A72H	—	—	●	●	—	—	—	—	—	—
	Connector	2-wire		24 V	12 V	100 V	A73	A73H	—	—	●	●	●	—	—	—	—	Relay, PLC
				12 V	—	—	A73C	—	—	—	—	●	●	●	●	—	—	
Diagnostic indication (2-color indication)	Grommet	—	—	—	—	—	A79W	—	—	—	●	●	—	—	—	—	—	
Solid state switch	—	Grommet	Yes	3-wire (NPN)	5 V, 12 V	—	F7NV	F79	M9NV	M9N	●	●	○	—	○	IC circuit	—	
				3-wire (PNP)			F7PV	F7P	M9PV	M9P	●	●	○	—	○	—		—
	Connector	2-wire		12 V	F7BV	J79	M9BV	M9B	●	●	○	—	○	—	—	—	—	
					J79C	—	—	—	●	●	●	●	—	—	—	—		
	Diagnostic indication (2-color indication)	Grommet		3-wire (NPN)	5 V, 12 V	—	F7NWV	F79W	F9NWV	F9NW	●	●	○	—	○	IC circuit	—	
							3-wire (PNP)	—	F7PW	F9PWV	F9PW	●	●	○	—	○		—
	Water resistant (2-color indication)	Grommet		2-wire	24 V	12 V	—	F7BWV	J79W	F9BWV	F9BW	●	●	○	—	○	—	Relay, PLC
								—	F7BA	—	F9BA	—	●	●	○	—	○	
With diagnostic output (2-color indication)	Grommet	4-wire (NPN)	5 V, 12 V	—	—	—	F79F	—	—	●	●	○	—	○	IC circuit	—		
						—	P5DW	—	—	—	●	●	—	○	—		—	
Magnetic field resistant (2-color indication)	Grommet	2-wire	—	—	—	—	—	—	—	—	●	●	—	○	—	—		

* Lead wire length symbols: 0.5 m.....Nil (Example) A73C
 3 m.....L (Example) A73CL
 5 m.....Z (Example) A73CZ
 None.....N (Example) A73CN

* Solid state switches marked with "○" are produced upon receipt of order.

- D-P5DWL type is available from ø40 up to ø100 only.
- There are other applicable auto switches other than the listed above. For details, refer to page 7-6-23.
- For details about auto switches with pre-wire connector, refer to page 7-9-36.

Compact Cylinder: Anti-lateral Load Type Double Acting, Single Rod Series CQ2

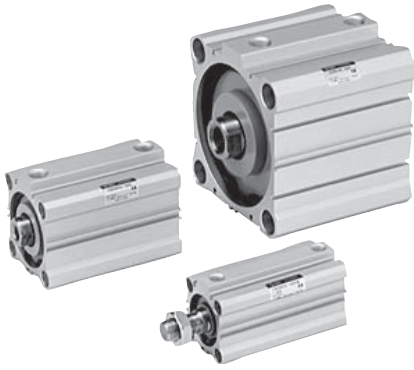

JIS symbol
Double acting,
Single rod

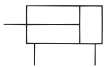

⚠ Precautions

Be sure to read before handling.
For Safety Instructions and Actuator Precautions, refer to pages 7-13-3 to 7-13-6.

⚠ Caution

Snap Ring Installation/Removal

- For installation and removal, use an appropriate pair of pliers (tool for installing a type C snap ring).
- Even if a proper plier (tool for installing type C snap ring) is used, it is likely to inflict damage to a human body or peripheral equipment, as a snap ring may be flown out of the tip of a plier (tool for installing a type C snap ring). Be much careful with the popping of a snap ring. Besides, be certain that a snap ring is placed firmly into the groove of rod cover before supplying air at the time of installment.



Made to Order Specifications (For details, refer to page 7-10-1.)

Symbol	Specifications
-XC6	Piston rod and rod end nut made of stainless steel
-XC18	NPT finish piping port
-X271	Fluoro rubber for seals

Type

Bore size (mm)		32	40	50	63	80	100
Pneumatic	Mounting	Through-hole (Standard)	●	●	●	●	●
		Both ends tapped style	●	●	●	●	●
	Built-in magnet	●	●	●	●	●	●
	Screw-in type	Rc 1/8	Rc 1/8	Rc 1/4	Rc 1/4	Rc 3/8	Rc 3/8
	Rod end male thread	●	●	●	●	●	●
	With rubber bumper (Standard)	●	●	●	●	●	●

Specifications

Type	Pneumatic (Non-lube)
Fluid	Air
Proof pressure	1.5 MPa
Maximum operating pressure	1.0 MPa
Ambient and fluid temperature	Without auto switch: -10 to 70°C (No freezing) With auto switch: -10 to 60°C (No freezing)
Cushion	Rubber bumper (Standard equipment)
Rod end thread	Female thread
Rod end thread tolerance	JIS Class 2
Stroke length tolerance	$^{+1.0}_0$
Mounting	Through-hole
Piston speed	50 to 500 mm/s

Minimum Operating Pressure

Bore size (mm)	32	40	50	63	80	100
Minimum operating pressure	0.05					

Allowable Kinetic Energy

Bore size (mm)	32	40	50	63	80	100
Allowable kinetic energy	0.29	0.52	0.91	1.54	2.71	4.54

Standard Stroke

Bore size (mm)	Standard stroke
32, 40	5, 10, 15, 20, 25, 30, 35, 40, 45, 50, 75, 100
50, 63, 80, 100	10, 15, 20, 25, 30, 35, 40, 45, 50, 75, 100

Manufacture of Intermediate Stroke

Description	Spacer is installed in the standard stroke body.	Exclusive body (-XB10)	
Part no.	Refer to "How to Order" for the standard model no. on page 7-6-132.	Suffix "-XB10" to the end of standard model no. on page 7-6-132.	
Description	Dealing with the stroke by the 1 mm interval is available by installing spacer with standard stroke cylinder.	Dealing with the stroke by the 1 mm interval by using an exclusive body with the specified stroke.	
Stroke range	Bore size	Bore size	Stroke range
	32 to 100	1 to 99	32, 40 50 to 100
Example	Part no.: CQ2BS50-57DC CQ2BS50-75DC with 18 mm width spacer. B dimension is 125.5 mm.	Part no.: CQ2BS50-57DC-XB10 Makes 57 stroke tube. B dimension is 107.5 mm.	

- In the case of an exclusive body with $\phi 32$ to 100 (-XB10) with the stroke length exceeding 50 mm, the reference values of the longitudinal dimension will be changed. Calculate length dimensions by deducting from those of 75 or 100 mm stroke models.

CUJ

CU

CQS

CQM

CQ2

RQ

MU

D-

-X

20-

Data

Series CQ2

Copper-free (For CRT manufacturing process)

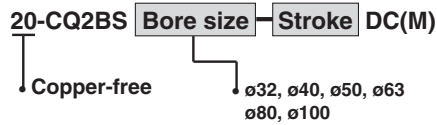

To prevent the influence of copper ions or halogen ions during CRT manufacturing processes, copper and fluorine materials are not used in the component parts.

Specifications

Action	Double acting, Single rod
Bore size (mm)	32, 40, 50, 63, 80, 100
Proof pressure	1.5 MPa
Max. operating pressure	1.0 MPa
Rubber bumper	With (Standard equipment)
Piping	Screw-in piping
Piston speed	50 to 500 mm/s
Mounting	Both ends tapped style
Auto switch	Mountable

Allowable Load at Rod End

Without Auto Switch

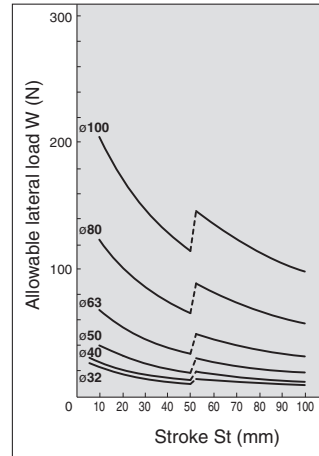

With Auto Switch

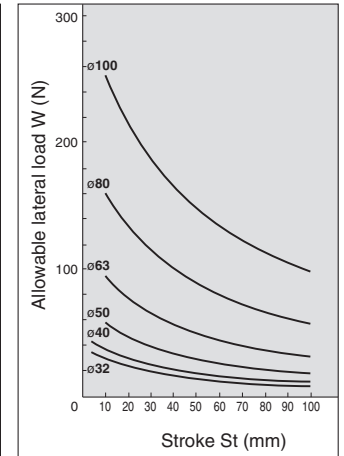

Theoretical Output

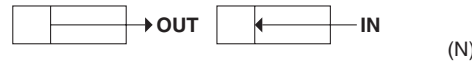

Bore size (mm)	Operating direction	Operating pressure (MPa)		
		0.3	0.5	0.7
32	IN	181	302	422
	OUT	241	402	563
40	IN	317	528	739
	OUT	377	628	880
50	IN	495	825	1155
	OUT	589	982	1374
63	IN	841	1402	1962
	OUT	935	1559	2182
80	IN	1361	2268	3175
	OUT	1508	2513	3519
100	IN	2144	3574	5003
	OUT	2356	3927	5498

Weight

Bore size (mm)	Cylinder stroke (mm)											
	5	10	15	20	25	30	35	40	45	50	75	100
32	142	163	184	204	225	246	267	287	308	329	482	587
40	224	247	270	293	316	339	362	386	409	432	616	736
50	—	400	436	472	508	545	581	617	653	690	982	1170
63	—	589	630	671	712	753	794	835	876	916	1264	1475
80	—	1079	1147	1215	1282	1350	1418	1486	1554	1622	2194	2528
100	—	1863	1953	2044	2135	2226	2316	2407	2498	2589	3393	3853

Additional Weight

Bore size (mm)		32	40	50	63	80	100
Both ends tapped style		6	6	6	19	45	45
Rod end male thread	Male thread	26	27	53	53	120	175
	Nut	17	17	32	32	49	116
Foot style (Including mounting bolt)		143	155	243	324	696	1062
Rod side flange style (Including mounting bolt)		180	214	373	559	1056	1365
Head side flange style (Including mounting bolt)		165	198	348	534	1017	1309
Double clevis style (Including pin, snap ring, bolt)		151	196	393	554	1109	1887

Calculation: (Example) CQ2DS32-20DCM

- Cylinder weight: CQ2BS32-20DC..... 204 g
- Option weight: Both ends tapped style..... 6 g
- Rod end male thread..... 43 g
- Double clevis style..... 151 g

404 g

Compact Cylinder: Anti-lateral Load Type Double Acting, Single Rod Series CQ2

Construction

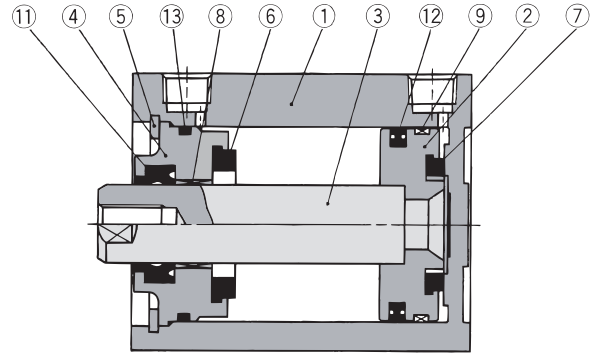
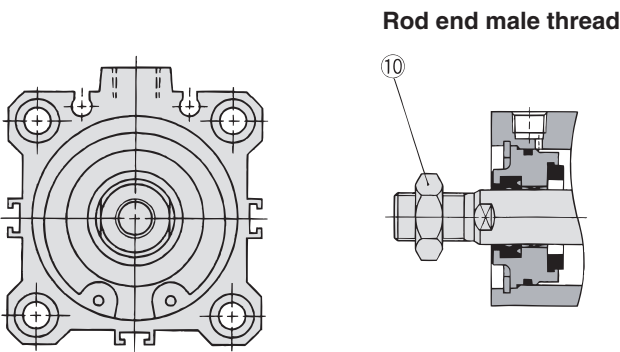

Component Parts

No.	Description	Material	Note
①	Cylinder tube	Aluminum alloy	Hard anodized
②	Piston	Aluminum alloy	Chromated
③	Piston rod	Carbon steel	Hard chrome plated
④	Collar	Aluminum alloy	Anodized
⑤	Snap ring	Carbon tool steel	Phosphate coated
⑥	Bumper A	Urethane	
⑦	Bumper B	Urethane	
⑧	Bushing	Phosphor bronze alloy	
⑨	Wear ring	Resin	
⑩	Rod end nut	Carbon steel	Nickel plated
⑪	Rod seal	NBR	
⑫	Piston seal	NBR	
⑬	Tube gasket	NBR	

Replacement Parts: Seal Kit

Bore size (mm)	Kit no.	Contents
32	CQ2B32-PS	Set of left nos. ⑪, ⑫, ⑬
40	CQ2B40-PS	
50	CQ2B50-PS	
63	CQ2B63-PS	
80	CQ2B80-PS	
100	CQ2B100-PS	

* Seal kit includes ⑪, ⑫, ⑬. Order the seal kit, based on each bore size.

Mounting Bracket Part No.

Bore size (mm)	Foot (1)	Flange	Double clevis
32	CQ-L032	CQ-F032	CQ-D032
40	CQ-L040	CQ-F040	CQ-D040
50	CQ-L050	CQ-F050	CQ-D050
63	CQ-L063	CQ-F063	CQ-D063
80	CQ-L080	CQ-F080	CQ-D080
100	CQ-L100	CQ-F100	CQ-D100

Note 1) Order two foot brackets per cylinder.
 Note 2) Parts belonging to each bracket are as follows: Foot, Flange/Body mounting bolt, Double clevis/Clevis pin, C shape snap ring for axis, Body mounting bolt.

Auto Switch Mounting Bracket Part No.

Bore size (mm)	Mounting bracket part no.	Note	Applicable auto switch	
			Reed switch	Solid state switch
32, 40 50, 63 80, 100	BQ-2	<ul style="list-style-type: none"> Switch mounting screw (M3 x 0.5 x 10 ϕ) Switch spacer Switch mounting nut 	D-A7□/A80 D-A73C/A80C D-A7□H/A80H D-A79W	D-F7□/J79 D-F7□V D-J79C D-F7□W/J79W D-F7□WV D-F7BAL/F7BAVL D-F79F
40 to 100	BQP1-050	<ul style="list-style-type: none"> Switch mounting bracket Switch mounting nut Hexagon socket head cap bolt (M3 x 0.5 x 14; spring washer 2 pcs.) Round head Phillips screw (M3 x 0.5 x 16; spring washer 2 pcs.) 	—	D-P5DWL

CUJ

CU

CQS

CQM

CQ2

RQ

MU

D-

-X

20-

Data

Compact Cylinder: Anti-lateral Load Series CDQ2 With Auto Switch



* Refer to page 7-9-1 for further information on auto switches.



Standard Specifications

Type	Pneumatic (Non-lube)
Fluid	Air
Ambient and fluid temperature	-10 to 60°C (No freezing)

Other specifications are the same as standard specifications on page 7-6-133.

How to Order

For "How to Order" with auto switch, refer to page 7-6-132.

Weight

Bore size (mm)	Cylinder stroke (mm)											
	5	10	15	20	25	30	35	40	45	50	75	100
32	201	222	243	263	284	305	326	346	367	388	493	598
40	300	323	347	370	393	416	439	462	485	508	628	748
50	—	518	554	590	626	663	699	735	771	808	996	1184
63	—	748	788	829	870	911	952	993	1034	1075	1286	1497
80	—	1340	1408	1476	1543	1611	1679	1747	1815	1883	2217	2552
100	—	2242	2333	2424	2514	2605	2696	2787	2877	2968	3428	3888

With auto switch

Calculation: (Example) CDQ2DS32-20DCM

- Cylinder weight: CDQ2BS32-20DC..... 263 g
 - Option weight: Both ends tapped style..... 6 g
 - Rod end male thread..... 43 g
 - Double clevis style..... 151 g
- 463 g

Additional Weight

Bore size (mm)	32	40	50	63	80	100
Both ends tapped style	6	6	6	19	45	45
Rod end male thread	Male thread	26	27	53	53	120
	Nut	17	17	32	32	49
Foot style (Including mounting bolt)	143	155	243	324	696	1062
Rod side flange style (Including mounting bolt)	180	214	373	559	1056	1365
Head side flange style (Including mounting bolt)	165	198	348	534	1017	1309
Double clevis style (Included pin, snap ring, bolt)	151	196	393	554	1109	1887

Add the weight of auto switches and mounting brackets when auto switches are mounted.

Auto Switch Mounting Bracket Weight

Mounting bracket part no.	Applicable bore size (mm)	Weight (g)
BQ-2	32 to 100	1.5

* For the auto switch weight, refer to page 7-9-1.

Construction

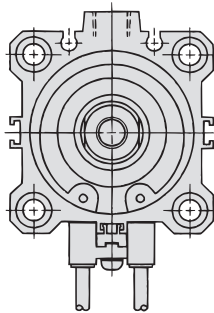

Rod end male thread

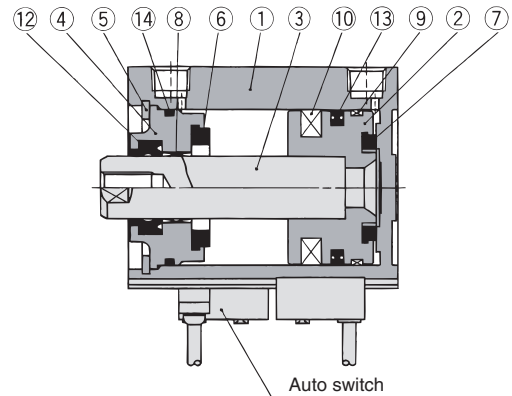
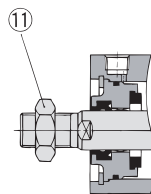

Component Parts

No.	Description	Material	Note
①	Cylinder tube	Aluminum alloy	Hard anodized
②	Piston	Aluminum alloy	Chromated
③	Piston rod	Carbon steel	Hard chrome plated
④	Collar	Aluminum alloy	Anodized
⑤	Snap ring	Carbon tool steel	Phosphate coated
⑥	Bumper A	Urethane	
⑦	Bumper B	Urethane	
⑧	Bushing	Lead-bronze casted	
⑨	Wear ring	Resin	
⑩	Magnet	—	
⑪	Rod end nut	Carbon steel	
⑫	Rod seal	NBR	
⑬	Piston seal	NBR	
⑭	Tube gasket	NBR	

Replacement Parts: Seal Kit

Bore size (mm)	Kit no.	Contents
32	CQ2B32-PS	Set of left nos. ⑫, ⑬, ⑭
40	CQ2B40-PS	
50	CQ2B50-PS	
63	CQ2B63-PS	
80	CQ2B80-PS	
100	CQ2B100-PS	

* Seal kit includes ⑫, ⑬, ⑭. Order the seal kit, based on each bore size.

Compact Cylinder with Auto Switch: Anti-lateral Load Type Double Acting, Single Rod Series **CDQ2**

Proper Auto Switch Mounting Position (Detection at stroke end) and Its Mounting Height

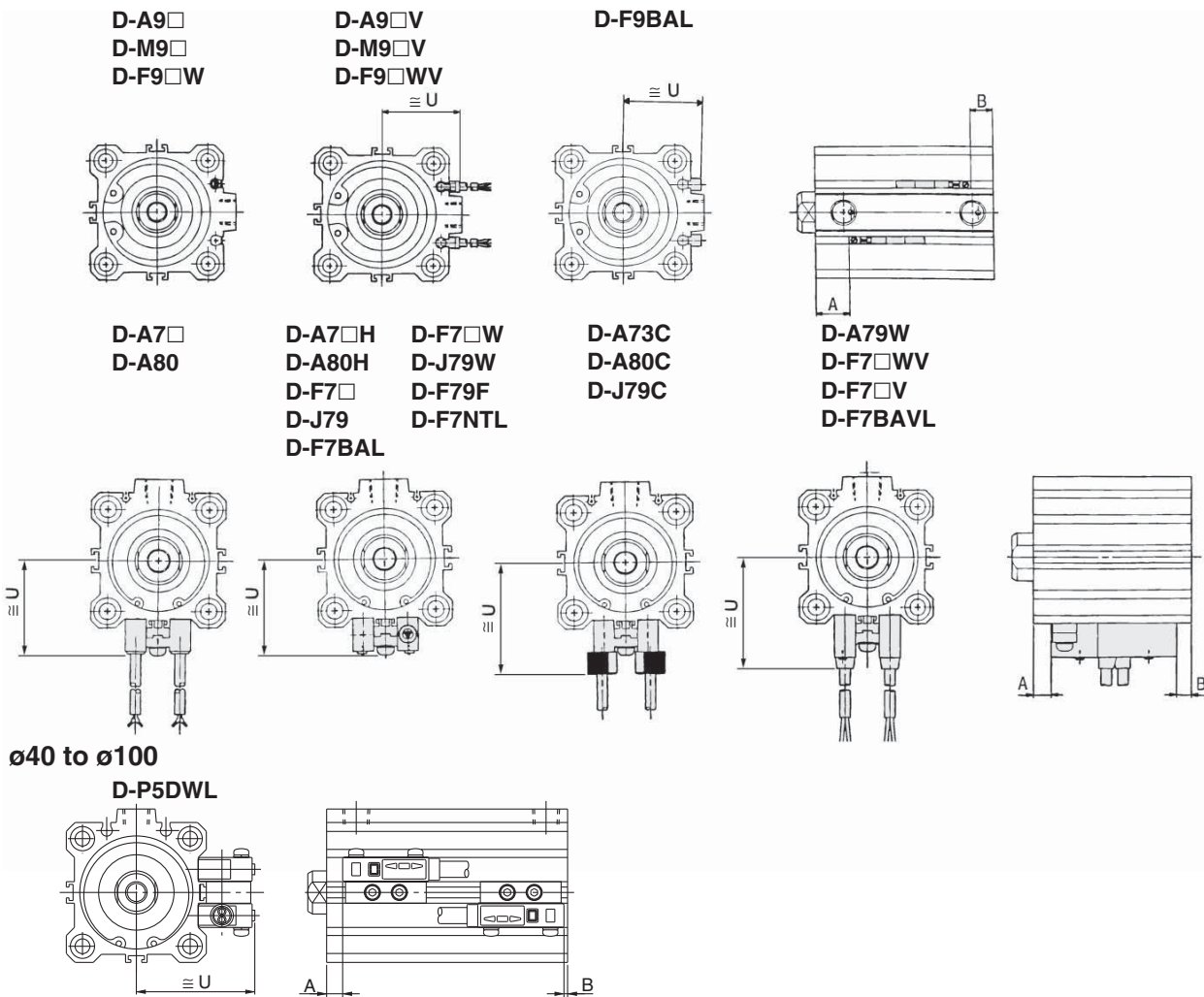

- CUJ
- CU
- CQS
- CQM
- CQ2
- RQ
- MU
- D-
- X
- 20-
- Data

Proper Auto Switch Mounting Position

Bore size (mm)	D-A7□/A80		D-A7□H/A80H D-A73C/A80C/F79F D-F7□/J79/J79W D-F7□V/J79C D-F7□W/F7□WV D-F7BAL/F7BAVL		D-A79W		D-A9□ D-A9□V		D-M9□ D-M9□V D-F9□W D-F9□WV		D-F9BAL		D-P5DWL	
	A	B	A	B	A	B	A	B	A	B	A	B	A	B
32	15	10	15.5	10.5	12.5	7.5	14	9	18	13	17	12	—	—
40	18.5	13	19	13.5	16	10.5	17.5	12	21.5	16	20.5	15	14.5	9
50	16	16.5	16.5	17	13.5	14	15	15.5	19	19.5	18	18.5	12	12.5
63	18.5	19.5	19	20	16	17	17.5	18.5	21.5	22.5	20.5	21.5	14.5	15.5
80	21.5	24	22	24.5	19	21.5	20.5	23	24.5	27	23.5	26	17.5	20
100	24.5	30.5	25	31	22	28	23.5	29.5	27.5	33.5	26.5	32.5	20.5	26.5

Auto Switch Mounting Height

Bore size (mm)	D-A7□/A80	D-A7□H/A80H D-F7□, D-J79, D-F7□W D-J79W, D-F7BAL D-F79F, D-F7NTL	D-A73C D-A80C	D-F7□V D-F7□WV D-F7BAVL	D-J79C	D-A79W	D-A9□V	D-M9□V D-F9□WV	D-F9BAL	D-P5DWL
	U	U	U	U	U	U	U	U	U	U
32	31.5	32.5	38.5	35	38	34	27	29	26.5	—
40	35	36	42	38.5	41.5	37.5	30.5	32.5	30	44
50	41	42	48	44.5	47.5	43.5	36.5	38.5	36	50
63	47.5	48.5	54.5	51	54	50	40	42	39.5	56.5
80	57.5	58.5	64.5	61	64	60	50	52	49.5	66.5
100	67.5	68.5	74.5	71	74	70	60	62	59.5	76.5

Series CQ2/CDQ2

Dimensions: $\phi 32$ to $\phi 50$

Basic style (Through-hole): CQ2BS/CDQ2BS

Both ends tapped style: CQ2AS/CDQ2AS

Both Ends Tapped Style

Bore size (mm)	O1	R
32	M6 x 1.0	10
40	M6 x 1.0	10
50	M8 x 1.25	14

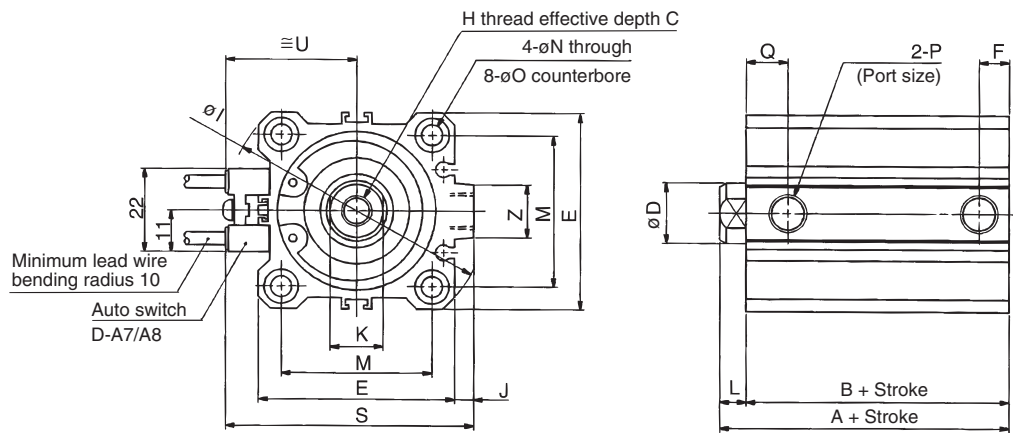
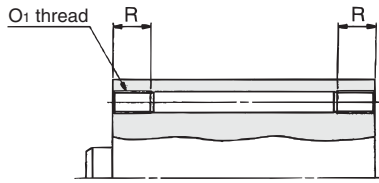

Rod end male thread

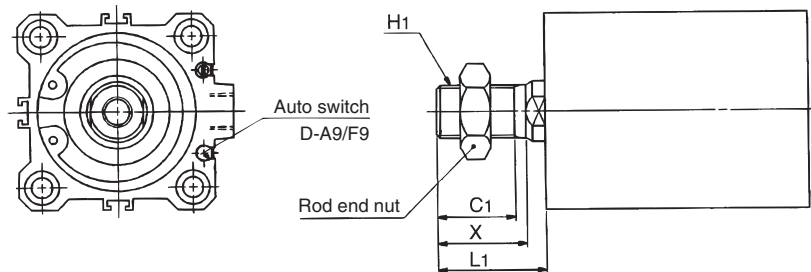

Dimensions of with boss in head side are equivalent to Series CQ2, double acting, single rod. Refer to page 7-6-16.

Rod End Male Thread

Bore size (mm)	C1	X	H1	L1
32	20.5	23.5	M14 x 1.5	28.5
40	20.5	23.5	M14 x 1.5	28.5
50	26	28.5	M18 x 1.5	33.5

Bore size (mm)	Stroke range (mm)	Without auto switch		With auto switch		C	D	E	F	H	I	J	K	L	M	N	O	P	Q	S	U	Z
		A	B	A	B																	
32	5 to 50	40	33	50	43	13	16	45	7.5	M8 x 1.25	60	4.5	14	7	34	5.5	9 depth 7	Rc 1/8	10.5	58.5	31.5	14
	75, 100	50	43																			
40	5 to 50	46.5	39.5	56.5	49.5	13	16	52	8	M8 x 1.25	69	5	14	7	40	5.5	9 depth 7	Rc 1/8	11	66	35	14
	75, 100	56.5	49.5																			
50	10 to 50	48.5	40.5	58.5	50.5	15	20	64	10.5	M10 x 1.5	86	7	17	8	50	6.6	11 depth 8	Rc 1/4	10.5	80	41	19
	75, 100	58.5	50.5																			

Compact Cylinder: Anti-lateral Load Type Double Acting, Single Rod Series **CQ2/CDQ2**

Foot style: CQ2LS/CDQ2LS

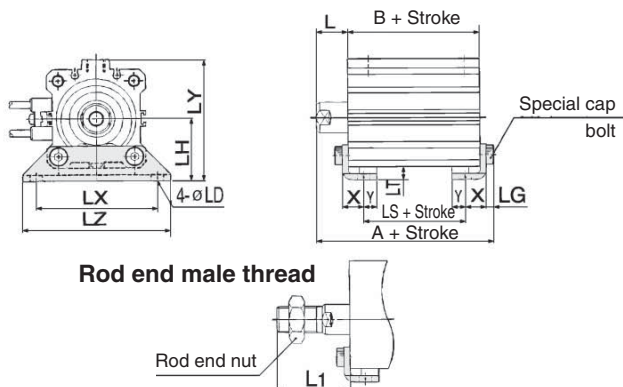

Rod side flange style: CQ2FS/CDQ2FS

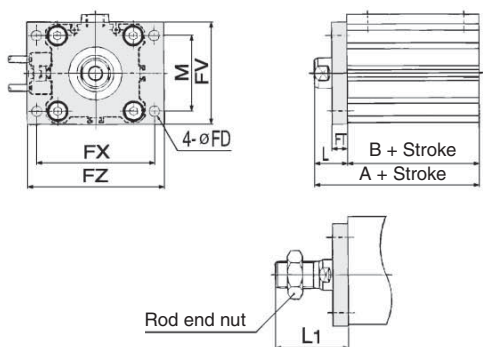

Head side flange style: CQ2GS/CDQ2GS

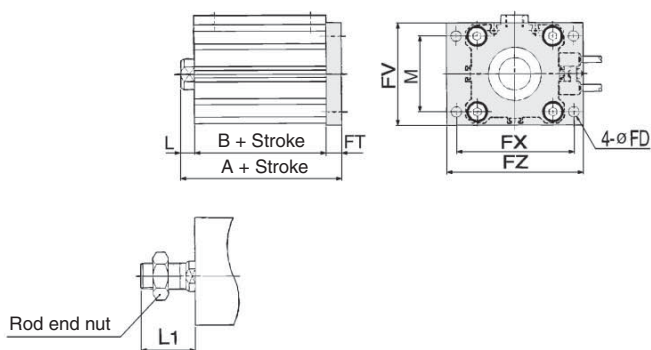

Double clevis style: CQ2DS/CDQ2DS

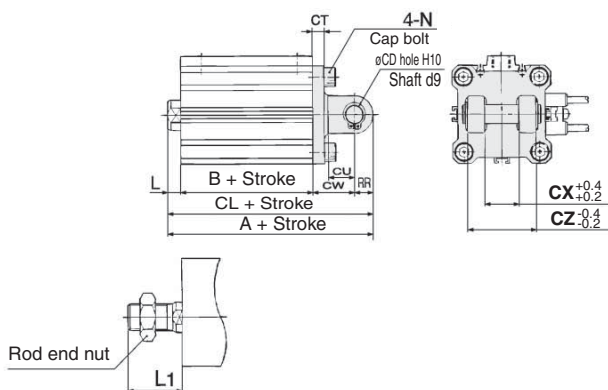

Foot Style

Bore size (mm)	Stroke range (mm)	Without auto switch			With auto switch			L	L1	LD
		A	B	LS	A	B	LS			
32	5 to 50	57.2	33	17	67.2	43	27	17	38.5	6.6
	75, 100	67.2	43	27						
40	5 to 50	63.7	39.5	23.5	73.7	49.5	33.5	17	38.5	6.6
	75, 100	73.7	49.5	33.5						
50	10 to 50	66.7	40.5	17.5	76.7	50.5	27.5	18	43.5	9
	75, 100	76.7	50.5	27.5						

Bore size (mm)	Stroke range (mm)	LG	LH	LT	LX	LY	LZ	X	Y
32	5 to 50	4	30	3.2	57	57	71	11.2	5.8
	75, 100								
40	5 to 50	4	33	3.2	64	64	78	11.2	7
	75, 100								
50	10 to 50	5	39	3.2	79	78	95	14.7	8
	75, 100								

Foot bracket material: Carbon steel

Rod Side Flange Style

Bore size (mm)	Stroke range (mm)	Without auto switch		With auto switch		FD	FT	FV	FX	FZ
		A	B	A	B					
32	5 to 50	50	33	60	43	5.5	8	48	56	65
	75, 100	60	43							
40	5 to 50	56.5	39.5	66.5	49.5	5.5	8	54	62	72
	75, 100	66.5	49.5							
50	10 to 50	58.5	40.5	68.5	50.5	6.6	9	67	76	89
	75, 100	68.5	50.5							

Bore size (mm)	Stroke range (mm)	L	L1	M
32	5 to 50	17	38.5	34
	75, 100			
40	5 to 50	17	38.5	40
	75, 100			
50	10 to 50	18	43.5	50
	75, 100			

Flange bracket material: Carbon steel

Head Side Flange Style

Bore size (mm)	Stroke range (mm)	Without auto switch	With auto switch	L	L1
		A	A		
32	5 to 50	48	58	7	28.5
	75, 100	58			
40	5 to 50	54.5	64.5	7	28.5
	75, 100	64.5			
50	10 to 50	57.5	67.5	8	33.5
	75, 100	67.5			

Flange bracket material: Carbon steel

(* Dimensions except A, L and L1 are same as rod side flange style.)

Double Clevis Style

Bore size (mm)	Stroke range (mm)	Without auto switch			With auto switch			CD	CT	CU
		A	B	CL	A	B	CL			
32	5 to 50	70	33	60	80	43	70	10	5	14
	75, 100	80	43	70						
40	5 to 50	78.5	39.5	68.5	88.5	49.5	78.5	10	6	14
	75, 100	88.5	49.5	78.5						
50	10 to 50	90.5	40.5	76.5	100.5	50.5	86.5	14	7	20
	75, 100	100.5	50.5	86.5						

Bore size (mm)	Stroke range (mm)	CW	CX	CZ	L	L1	N	RR
32	5 to 50	20	18	36	7	28.5	M6 x 1.0	10
	75, 100							
40	5 to 50	22	18	36	7	28.5	M6 x 1.0	10
	75, 100							
50	10 to 50	28	22	44	8	33.5	M8 x 1.25	14
	75, 100							

* For details about the rod end nut and accessory brackets, refer to page 7-6-20.

* Clevis pin and set ring are shipped together.

CUJ

CU

CQS

CQM

CQ2

RQ

MU

D-

-X

20-

Data

Series CQ2/CDQ2

(In the case of auto switches, A and B dimensions will be only changed. Refer to the dimension chart.)

Dimensions: $\phi 63$ to $\phi 100$

Basic style (Through-hole): CQ2BS/CDQ2BS

Both ends tapped style: CQ2AS/CDQ2AS

Dimensions of with boss in head side are equivalent to Series CQ2, double acting, single rod. Refer to page 7-6-18.

Both Ends Tapped Style

Bore size (mm)	O1	R
63	M10 x 1.5	18
80	M12 x 1.75	22
100	M12 x 1.75	22

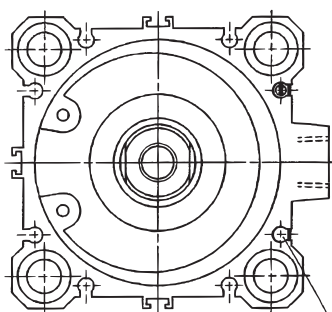
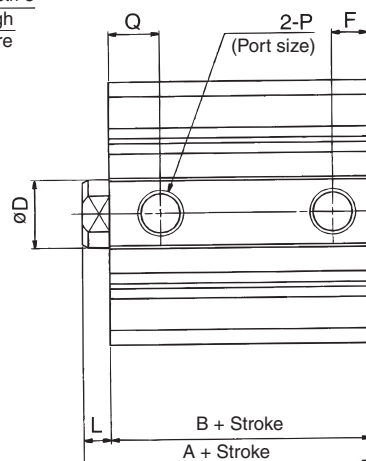
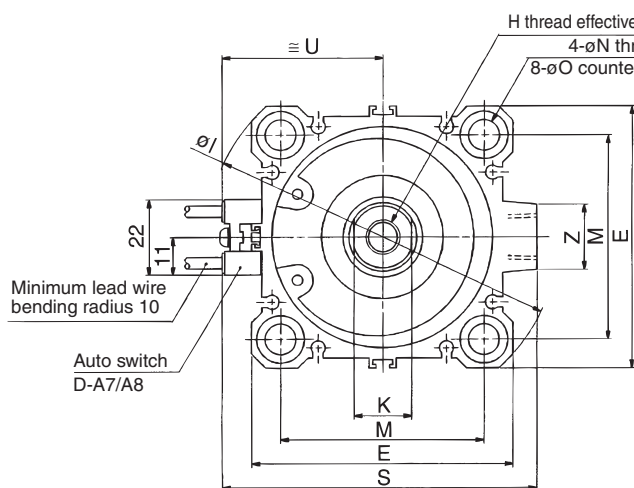
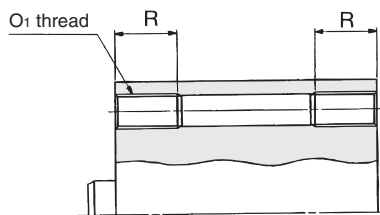

Rod end male thread

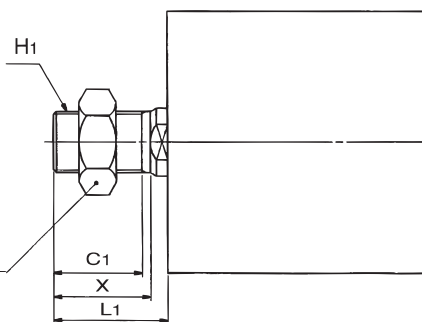

Rod End Male Thread

Bore size (mm)	C1	X	H1	L1
63	26	28.5	M18 x 1.5	33.5
80	32.5	35.5	M22 x 1.5	43.5
100	32.5	35.5	M26 x 1.5	43.5

Bore size (mm)	Stroke range (mm)	Without auto switch		With auto switch		C	D	E	F	H	I	J	K	L	M	N	O	P	Q	S	U	Z
		A	B	A	B																	
63	10 to 50	54	46	64	56	15	20	77	10.5	M10 x 1.5	103	7	17	8	60	9	14 depth 10.5	Rc 1/4	15	93	47.5	19
	75, 100	64	56																			
80	10 to 50	63.5	53.5	73.5	63.5	21	25	98	12.5	M16 x 2.0	132	6	22	10	77	11	17.5 depth 13.5	Rc 3/8	16	112.5	57.5	26
	75, 100	73.5	63.5																			
100	10 to 50	75	63	85	73	27	30	117	13	M20 x 2.5	156	6.5	27	12	94	11	17.5 depth 13.5	Rc 3/8	23	132.5	67.5	26
	75, 100	85	73																			

Compact Cylinder: Anti-lateral Load Type Double Acting, Single Rod Series **CQ2/CDQ2**

Foot style: CQ2LS/CDQ2LS

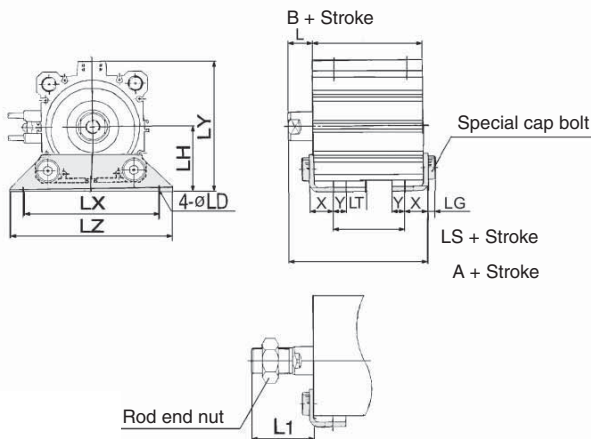

Rod side flange style: CQ2FS/CDQ2FS

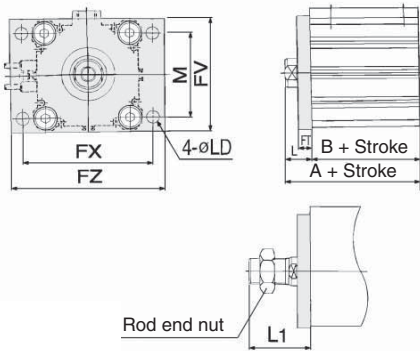

Head side style: CQ2GS/CDQ2GS

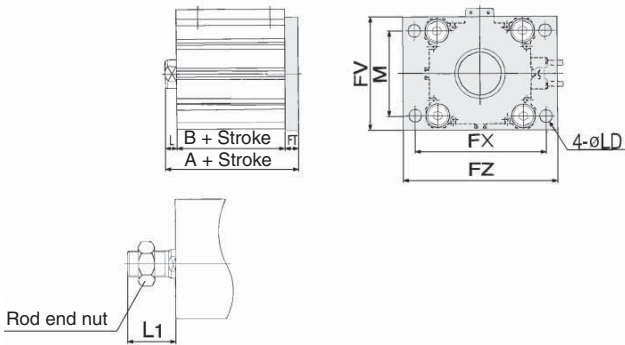

Double clevis style: CQ2DS/CDQ2DS

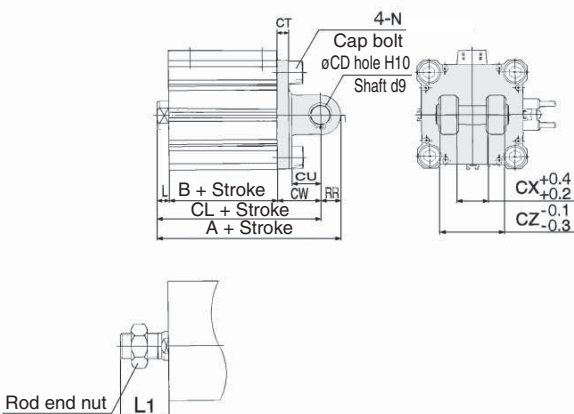

Foot Style

Bore size (mm)	Stroke range (mm)	Without auto switch			With auto switch			L	L1	LD
		A	B	LS	A	B	LS			
63	10 to 50	72.2	46	20	82.2	56	30	18	43.5	11
	75, 100	82.2	56	30						
80	10 to 50	85	53.5	23.5	95	63.5	33.5	20	53.5	13
	75, 100	95	63.5	33.5						
100	10 to 50	98	63	29	108	73	39	22	53.5	13
	75, 100	108	73	39						

Bore size (mm)	Stroke range (mm)	LG	LH	LT	LX	LY	LZ	X	Y
63	10 to 50	5	46	3.2	95	91.5	113	16.2	9
	75, 100								
80	10 to 50	7	59	4.5	118	114	140	19.5	11
	75, 100								
100	10 to 50	7	71	6	137	136	162	23	12.5
	75, 100								

Foot bracket material: Carbon steel

Rod Side Flange Style

Bore size (mm)	Stroke range (mm)	Without auto switch		With auto switch		FD	FT	FV	FX	FZ
		A	B	A	B					
63	10 to 50	64	46	74	56	9	9	80	92	108
	75, 100	74	56							
80	10 to 50	73.5	53.5	83.5	63.5	11	11	99	116	134
	75, 100	83.5	63.5							
100	10 to 50	85	63	95	73	11	11	117	136	154
	75, 100	95	73							

Bore size (mm)	Stroke range (mm)	L	L1	M
63	10 to 50	18	43.5	60
	75, 100			
80	10 to 50	20	53.5	77
	75, 100			
100	10 to 50	22	53.5	94
	75, 100			

Flange bracket material: Carbon steel

Head Side Flange Style

Bore size (mm)	Stroke range (mm)	Without auto switch		With auto switch	
		A	B	A	B
63	10 to 50	63		73	8
	75, 100	73			
80	10 to 50	74.5		84.5	10
	75, 100	84.5			
100	10 to 50	86		96	12
	75, 100	96			

* Dimensions except A, L and L1 are same as rod side flange style.
Flange bracket material: Carbon steel

Double Clevis Style

Bore size (mm)	Stroke range (mm)	Without auto switch			With auto switch			CD	CT	CU
		A	B	CL	A	B	CL			
63	10 to 50	98	46	84	108	56	94	14	8	20
	75, 100	108	56	94						
80	10 to 50	119.5	53.5	101.5	129.5	63.5	111.5	18	10	27
	75, 100	129.5	63.5	111.5						
100	10 to 50	142	63	120	152	73	130	22	13	31
	75, 100	152	73	130						

Bore size (mm)	Stroke range (mm)	CW	CX	CZ	L	L1	N	RR
63	10 to 50	30	22	44	8	33.5	M10 x 1.5	14
	75, 100							
80	10 to 50	38	28	56	10	43.5	M12 x 1.75	18
	75, 100							
100	10 to 50	45	32	64	12	43.5	M12 x 1.75	22
	75, 100							

* For details about the rod end nut and accessory brackets, refer to page 7-6-20.
* Clevis pin and set ring are shipped together.

CUJ

CU

CQS

CQM

CQ2

RQ

MU

D-

-X

20-

Data

Compact Cylinder: With End Lock

Series *CBQ2*

ø20, ø25, ø32, ø40, ø50, ø63, ø80, ø100

How to Order

Without auto switch

CBQ2 B 40 30 D C H N

With auto switch

CDBQ2 B 40 30 D C H N F9BW

Built-in magnet

Mounting style

ø20, ø25		ø32 to ø100	
B	Through-hole/Both ends tapped common (Standard)	B	Through-hole (Standard) ⁽¹⁾
L	Foot style	L	Foot style
F	Rod side flange style	F	Rod side flange style
G	Head side flange style	G	Head side flange style
D	Double clevis style	D	Double clevis style

* Mounting brackets are shipped together, (but not assembled).

Note 1) At the 75, and 100 strokes with ø80, ø100, both ends tapped (A) is the standard. Through-hole (B) is not available.

Note 2) Mounting brackets are shipped together, (but not assembled).

Bore size

20	25	32	40	50	63	80	100
20 mm	25 mm	32 mm	40 mm	50 mm	63 mm	80 mm	100 mm

Cylinder stroke (mm)

For "Standard Stroke" and "Manufacture of intermediate of Stroke", refer to page 7-6-143.

Number of auto switches

Nil	2 pcs.
S	1 pc.
n	"n" pcs.

Auto switch

Nil	Without auto switch (Built-in magnet)
-----	---------------------------------------

* For the applicable auto switch model, refer to the table below.

Manual release type

N	Non-lock type
L	Lock type

Lock position

H	Head end lock
R	Rod end lock

Body option

C	With rubber bumper, Rod end female thread (Standard)
CM	With rubber bumper, Rod end male thread

Action

D	Double acting
----------	---------------

Applicable Auto Switch/Refer to page 7-9-1 for further information on auto switches.

Type	Special function	Electrical entry	Indicator light	Wiring (Output)	Load voltage		Rail mounting		Direct mounting		Lead wire length (m)*				Pre-wire connector	Applicable load					
					DC	AC	ø32 to ø100		ø20 to ø100		0.5 (Nil)	3 (L)	5 (Z)	None (N)		IC circuit	Relay, PLC				
							Perpendicular	In-line	Perpendicular	In-line											
Reed switch	—	Grommet	Yes	3-wire (NPN equivalent)	—	5 V	—	A76H	A96V	A96	●	●	—	—	—	IC circuit	—				
											—	—	—	—							
	Diagnostic indication (2-color indication)	Connector		2-wire	24 V	12 V	100 V	—	—	A93V	A93	●	●	—	—	—	Relay, PLC				
												—	—	—	—						
Solid state switch	—	Grommet	Yes	3-wire (NPN)	—	5 V, 12 V	—	F7NV	F79	F9NV	F9N	●	●	○	—	—	IC circuit				
												3-wire (PNP)	●	●	○			—			
	Diagnostic indication (2-color indication)	Connector		2-wire	24 V	12 V	—	—	F7BV	J79	F9BV	F9B	●	●	○	—	—	Relay, PLC			
													J79C	—	—	—			●	●	—
	Water resistant (2-color indication)	Grommet	2-wire	24 V	5 V, 12 V	—	—	F7NVV	F79W	F9NVV	F9NW	●	●	○	—	—	IC circuit				
												—	F7PW	F9PWV	F9PW			●	●	○	—
												F7BWW	J79W	F9BWW	F9BW			●	●	○	—
												—	F7BA	—	F9BA			—	●	○	—
With diagnostic output (2-color indication)	Grommet	4-wire (NPN)	24 V	12 V	—	—	F7BAV	—	—	—	—	●	○	—	—	IC circuit					
											—	F79F	—	—			●	●	○	—	

* Lead wire length symbols: 0.5 m.....Nil (Example) A73C
 3 m.....L (Example) A73CL
 5 m.....Z (Example) A73CZ
 None.....N (Example) A73CN

* Solid state switches marked with "○" are produced upon receipt of order.
 • Since there are other applicable auto switches than listed, refer to page 7-6-23 for details.
 • For details about auto switches with pre-wire connector, refer to page 7-9-36.

Compact Cylinder with End Lock Series CBQ2



Cylinder Specifications

Fluid	Air
Proof pressure	1.5 MPa
Maximum operating pressure	1.0 MPa
Minimum operating pressure	0.15 MPa *
Ambient and fluid temperature	Without auto switch: -10 to 70°C (No freezing) With auto switch: -10 to 60°C (No freezing)
Lubrication	Non-lube
Cushion	Rubber bumper on both ends (Standard)
Rod end thread tolerance	JIS Class 2
Stroke length tolerance	$\begin{matrix} +1.0 \\ 0 \end{matrix}$
Piston speed	50 to 500 mm/s

* 0.05 MPa except for the lock unit.

Lock Specifications

Lock position	Head end, Rod end							
Holding force (Max.) (N)	ø20	ø25	ø32	ø40	ø50	ø63	ø80	ø100
	215	330	550	860	1340	2140	3450	5390
Pressure for unlocking	0.15 MPa or less							
Backlash	2 mm or less							
Manual release	Non-lock type, Lock type							

Standard Stroke

Bore size (mm)	Standard stroke (mm)
20 to 63	10, 15, 20, 25, 50, 75, 100
80, 100	25, 50, 75, 100

Manufacture of Intermediate Stroke

Description	Spacer is installed in the standard stroke body.	
Part no.	Refer to "How to Order" for the standard model no. on page 7-6-142.	
Description	Dealing with the stroke by the 5 mm interval is available by installing spacer with standard stroke cylinder.	
Stroke range	Bore size (mm)	Stroke range
	20 to 100	5 to 95
Example	Part no.: CBQ2B40-45DC-HL CBQ2B40-50DC-HL with 5 mm width spacer inside.	

Mounting Bracket Part No.

Bore size (mm)	Foot ⁽¹⁾	Flange	Double clevis ⁽²⁾
20	CQS-L020	CQS-F020	CQS-D020
25	CQS-L025	CQS-F025	CQS-D025
32	CQ-L032	CQ-F032	CQ-D032
40	CQ-L040	CQ-F040	CQ-D040
50	CQ-L050	CQ-F050	CQ-D050
63	CQ-L063	CQ-F063	CQ-D063
80	CQ-L080	CQ-F080	CQ-D080
100	CQ-L100	CQ-F100	CQ-D100

Note 1) When ordering foot bracket, order 2 pieces per cylinder.
 Note 2) Parts belonging to each bracket are as follows. Foot or Flange style: Body mounting bolt, Double clevis style: Clevis pin, snap ring retainer, body mounting bolt.
 Note 3) Clevis pin and snap ring are included with the double clevis style.

CUJ

CU

CQS

CQM

CQ2

RQ

MU

D-

-X

20-

Data

⚠️ Precautions

Be sure to read before handling. For Safety Instructions and Actuator Precautions, refer to pages 7-13-3 to 7-13-6.

Use the Recommended Pneumatic Circuit

⚠️ Caution

• This is necessary for the correct locking and unlocking actions.

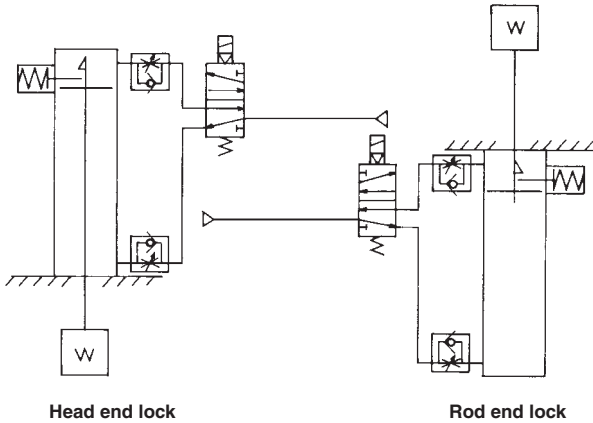

Head end lock

Rod end lock

Operating Precautions

⚠️ Caution

1. Do not use 3 position solenoid valves.

Avoid use in combination with 3 position solenoid valves (especially closed center metal seal types). If pressure is trapped in the port on the lock mechanism side, the cylinder cannot be locked. Furthermore, even after being locked, the lock may be released after some time, due to air leaking from the solenoid valve and entering the cylinder.

2. Back pressure is required when releasing the lock.

Before starting operation, be sure to control the system so that air is supplied to the side without the lock mechanism as shown in the figure above. There is a possibility that the lock may not be released. (Refer to the section on releasing the lock.)

3. Release the lock when mounting or adjusting the cylinder.

If mounting or other work is performed when the cylinder is locked, the lock unit may be damaged.

4. Operate with a load ratio of 50% or less.

If the load ratio exceeds 50%, this may cause problems such as failure of the lock to release, or damage to the lock unit.

5. Do not operate multiple cylinders in synchronization.

Avoid applications in which two or more end lock cylinders are synchronized to move one workpiece, as one of the cylinder locks may not be able to release when required.

6. Use a speed controller with meter-out control.

Lock cannot be released occasionally by meter-in control.

7. Be sure to operate completely to the cylinder stroke end on the side with the lock.

If the cylinder piston does not reach the end of stroke, locking and unlocking may not be possible.

8. Adjust the position of an auto switch, so that it could work at the both positions where it is distanced from the stroke and a backlash (2 mm).

When a 2-color indication switch is adjusted for green indication at the stroke end, it may change to red for the backlash return, but this is not abnormal.

Operating Pressure

⚠️ Caution

1. Supply air pressure of 0.15 MPa or higher to the port on the side that has the lock mechanism, as it is necessary for disengaging the lock.

Exhaust Speed

⚠️ Caution

1. When the pressure on the side with the lock mechanism drops to 0.05 MPa or below, the lock engages automatically. If the piping on the side with the lock mechanism is thin and long, or if the speed controller is away from the cylinder port, the lock engagement may take some due to decline of the exhaust speed. The same result will be caused by clogging of the silencer installed at the EXH port of the solenoid valve.

Releasing the Lock

⚠️ Caution

1. Before releasing the lock, be sure to supply air to the side without the lock mechanism, so that there is no load applied to the lock mechanism when it is released. If the lock is released when the port on the other side is in an exhaust state, and with a load applied to the lock unit, the lock unit may be subjected to an excessive force and be damaged. Also, it is very dangerous because the piston rod will be rushed to move.

Manual Release

⚠️ Caution

1. Manual release (Non-lock type)

Insert the accessory bolt from the top of the rubber cap (it is not necessary to remove the rubber cap), and after screwing it into the lock piston, pull it to release the lock. If you stop pulling the bolt, the lock will return to an operational state.

Thread sizes, pulling forces and strokes are as shown below.

Bore size (mm)	Thread size	Pulling force (N)	Stroke (mm)
20, 25, 32	M2.5 x 0.45 x 25ℓ or more	4.9	2
40, 50, 63	M3 x 0.5 x 30ℓ or more	10	3
80, 100	M5 x 0.8 x 40ℓ or more	24.5	3

Remove the bolt for normal operation. It can cause lock malfunction or faulty release.

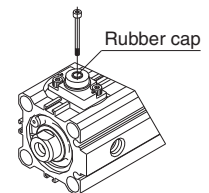

2. Manual release (Lock type)

While pushing the M/O knob, turn it 90° counterclockwise. The lock is released (and remains in a released state) by aligning the ▲ mark on the cap with the ▼ OFF mark on the M/O knob. When locking is desired, turn M/O button clockwise 90° while pushing fully, correspond ▲ on cap and ▼ ON mark on M/O button. The correct position is confirmed by a click sound "click". If not confirmed, locking is not done.

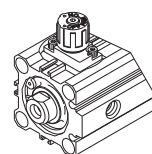

Manually locked state

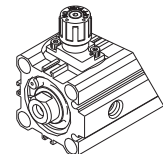

Manually unlocked state

Compact Cylinder with End Lock Series CBQ2

Construction

ø32 to ø63

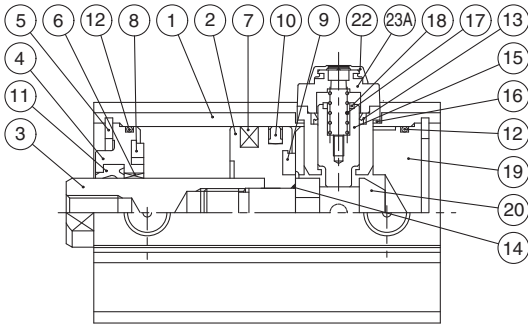

Head end lock

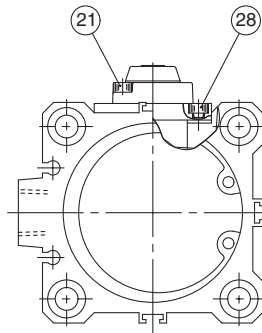

Cylinder tube form for ø32 to ø63

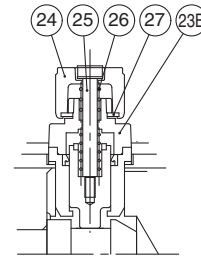

Manual release (Lock type): Suffix L

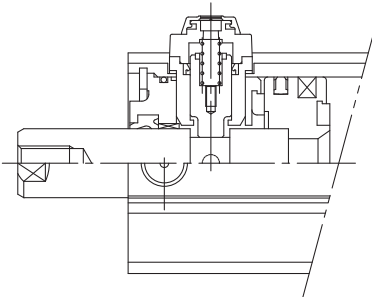

Rod end lock

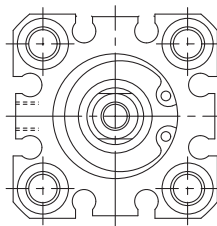

Cylinder tube form for ø25 or less

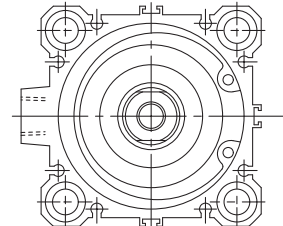

Cylinder tube form for ø63 or more

ø20, 25

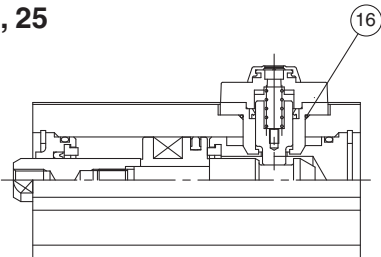

ø80, 100

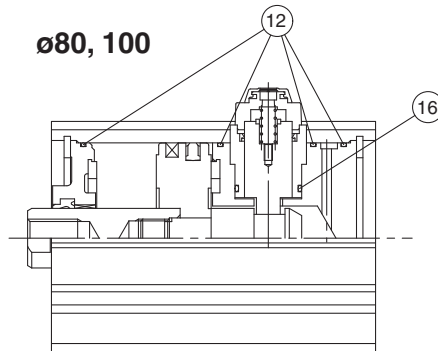

Component Parts

No.	Part	Material	Note
①	Cylinder tube	Aluminum alloy	Hard anodized
②	Piston	Aluminum alloy	Chromated
③	Piston rod	Carbon steel	Hard chrome plated
④	Collar	R□ Aluminum alloy	Anodized
		H□ Aluminum bearing alloy	ø 40 or less, Anodized
		Aluminum alloy casting	ø50 or more, Painted after chromated
⑤	Snap ring	Carbon tool steel	Phosphate coated
⑥	Bushing	Lead-bronze casted	R□ Used for all bore sizes
			H□ Used for ø40 and larger
⑦	Magnet	—	With auto switch
⑧	Bumper A	Urethane	
⑨	Bumper B	Urethane	
⑩	Piston seal	NBR	
⑪	Rod seal	NBR	
⑫	Tube gasket	NBR	Using 4 pcs. for ø80, 100
⑬	Lock piston seal	NBR	
⑭	Piston gasket	NBR	Nothing for ø20, 25
⑮	Lock piston	Carbon steel	Quenched, hard chrome plated
⑯	Gasket	NBR	
⑰	Lock spring	Stainless steel	
⑱	Bumper	Urethane	
⑲	Head cover	Aluminum alloy	Anodized
⑳	Lock bolt	Carbon steel	Quenched, Electroless nickel plated
㉑	Hexagon socket head cap screw	Alloy steel	Black zinc chromated
㉒	Rubber cap	Synthetic rubber	
㉓A	Cap A	Aluminum casted	Black painted
㉓B	Cap B	Carbon steel	Oxide film treated
㉔	M/O knob	Zinc die-casted	Black painted
㉕	M/O bolt	Alloy steel	Red painted
㉖	M/O spring	Steel wire	Zinc chromated
㉗	Stopper ring	Rolled steel	Zinc chromated
㉘	Hexagon socket head cap screw	Alloy steel	Nickel plated

CUJ

CU

CQS

CQM

CQ2

RQ

MU

D-

-X

20-

Data

Series CBQ2

Dimensions: $\phi 20$, $\phi 25$

Basic style (Through-hole/Both ends tapped common): CBQ2B/CDBQ2B

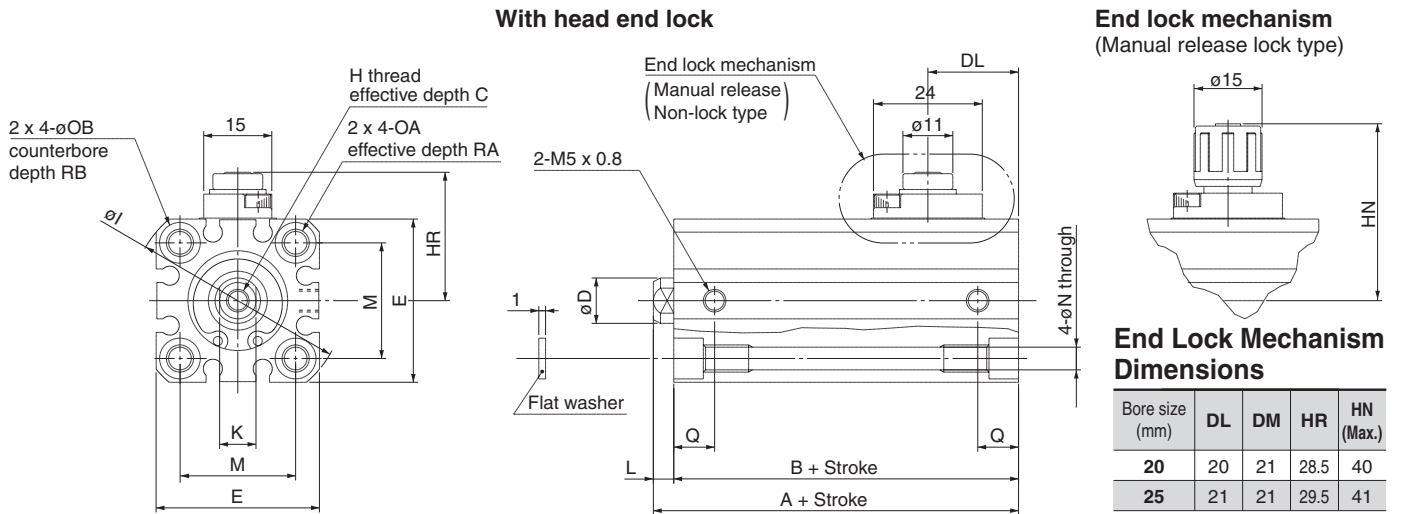

With rod end lock

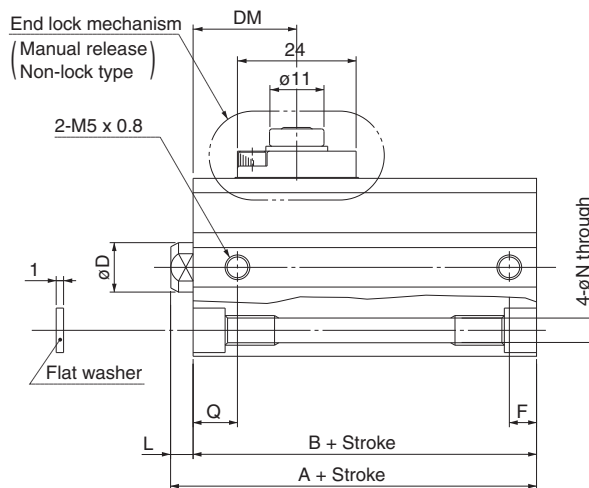

Rod end male thread

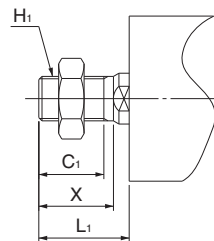

Bore size (mm)	Standard stroke	C ₁	X	H _i	L ₁
20	10, 15, 20, 25	12	14	M8 x 1.25	18.5
	50, 75, 100				28.5
25	10, 15, 20, 25	15	17.5	M10 x 1.25	22.5
	50, 75, 100				32.5

Bore size (mm)	Standard stroke	With head end lock				With rod end lock				C	D	E	H	I	K	M	N	OA	OB	Q	RA	RB
		A	B	L	A	B	F	L														
20	10, 15, 20, 25	65.5	61	4.5	59	54.5	5.5	4.5	7	10	36	M5 x 0.8	47	8	25.5	5.4	M6 x 1.0	9	9	10	7	
	50, 75, 100	80.5	66	14.5	80.5	66	9	14.5														
25	10, 15, 20, 25	69	64	5	62.5	57.5	5.5	5	12	12	40	M6 x 1.0	52	10	28	5.4	M6 x 1.0	9	11	10	7	
	50, 75, 100	84	69	15	84	69	11	15														

Compact Cylinder with End Lock Series CBQ2

Dimensions: $\phi 20$, $\phi 25$

Foot style: CBQ2L/CDBQ2L

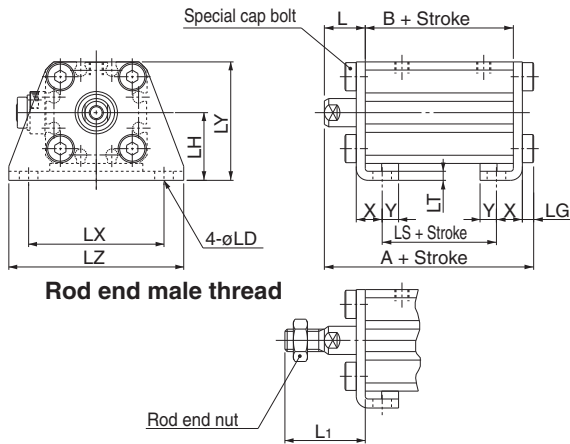

Foot Style

Bore size (mm)	Standard stroke	With head end lock			With rod end lock		
		A	B	LS	A	B	LS
20	10, 15, 20, 25	82.7	61	49	76.2	54.5	42.5
	50, 75, 100	87.7	66	54	87.7	66	54
25	10, 15, 20, 25	86.2	64	49	79.7	57.5	42.5
	50, 75, 100	91.2	69	54	91.2	69	54

Bore size (mm)	Standard stroke	L	L ₁	LD	LG	LH	LT	LX	LY	LZ	X	Y
20	10, 15, 20, 25	14.5	28.5	6.6	4	24	3.2	48	42	62	9.2	5.8
	50, 75, 100	15	32.5	6.6	4	26	3.2	52	46	66	10.7	5.8

Rod side flange style: CBQ2F/CDBQ2F

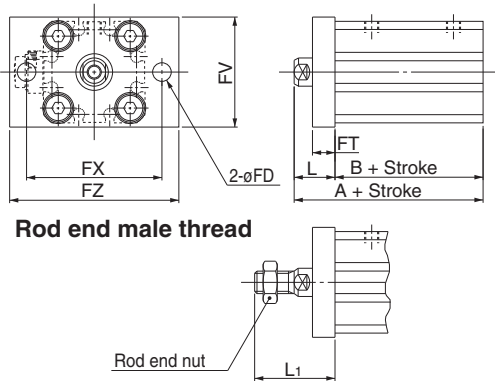

Rod Side Flange Style

Bore size (mm)	Standard stroke	With head end lock		With rod end lock	
		A	B	A	B
20	10, 15, 20, 25	75.5	61	69	54.5
	50, 75, 100	80.5	66	80.5	66
25	10, 15, 20, 25	79	64	72.5	57.5
	50, 75, 100	84	69	84	69

Bore size (mm)	Standard stroke	FD	FT	FV	FX	FZ	L	L ₁
20	10, 15, 20, 25	6.6	8	39	48	60	14.5	28.5
	50, 75, 100	6.6	8	42	52	64	15	32.5

Head side flange style: CBQ2G/CDBQ2G

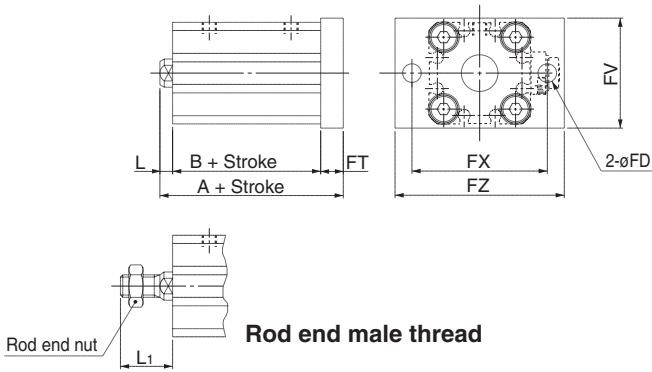

Head Side Flange Style

Bore size (mm)	Standard stroke	With head end lock				With rod end lock			
		A	B	L	L ₁	A	B	L	L ₁
20	10, 15, 20, 25	73.5	61	4.5	18.5	67	54.5	4.5	18.5
	50, 75, 100	88.5	66	14.5	28.5	88.5	66	14.5	28.5
25	10, 15, 20, 25	77	64	5	22.5	70.5	57.5	5	22.5
	50, 75, 100	92	69	15	32.5	92	69	15	32.5

Bore size (mm)	Standard stroke	FD	FT	FV	FX	FZ
20	10, 15, 20, 25	6.6	8	39	48	60
	50, 75, 100	6.6	8	42	52	64

Double clevis style: CBQ2D/CDBQ2D

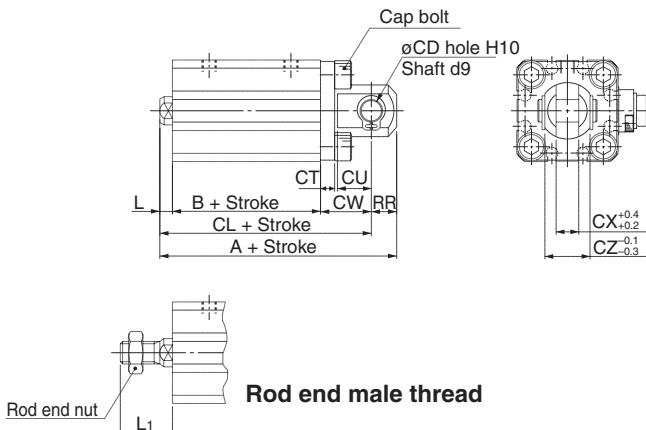

Double Clevis Style

Bore size (mm)	Standard stroke	With head end lock					With rod end lock				
		A	B	CL	L	L ₁	A	B	CL	L	L ₁
20	10, 15, 20, 25	92.5	61	83.5	4.5	18.5	86	54.5	77	4.5	18.5
	50, 75, 100	107.5	66	98.5	14.5	28.5	107.5	66	98.5	14.5	28.5
25	10, 15, 20, 25	99	64	89	5	22.5	92.5	57.5	82.5	5	22.5
	50, 75, 100	114	69	104	15	32.5	114	69	104	15	32.5

Bore size (mm)	Standard stroke	CD	CT	CU	CW	CX	CZ	RR
20	10, 15, 20, 25	8	5	12	18	8	16	9
	50, 75, 100	10	5	14	20	10	20	10

CUJ

CU

CQS

CQM

CQ2

RQ

MU

D-

-X

20-

Data

Series CBQ2

Dimensions: $\phi 32$ to $\phi 100$

Basic style (Through-hole): CBQ2B/CDBQ2B

Both ends tapped style: CBQ2A/CDBQ2A

Bore size (mm)	O ₁	R ₁
32	M6 x 1.0	10
40	M6 x 1.0	10
50	M8 x 1.25	14
63	M10 x 1.5	18
80	M12 x 1.75	22
100	M12 x 1.75	22

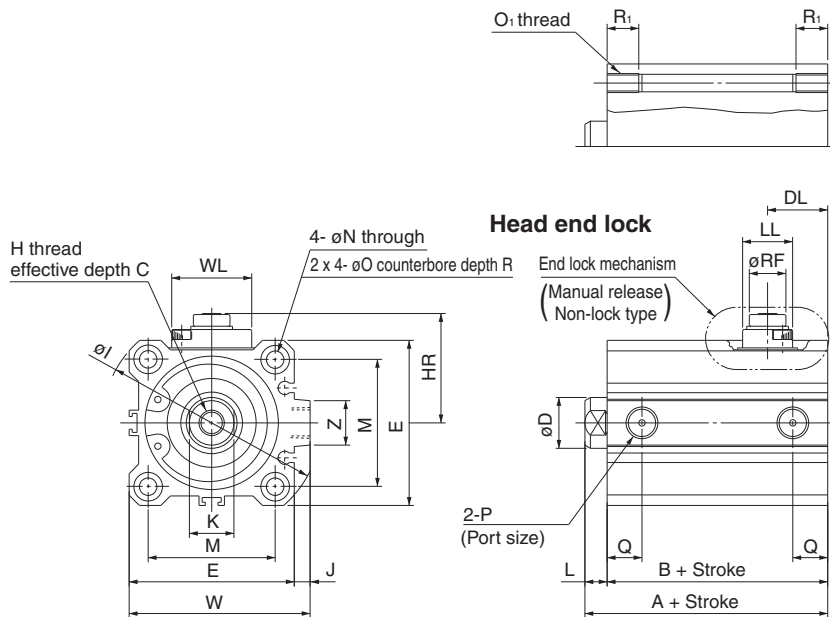

Rod end lock

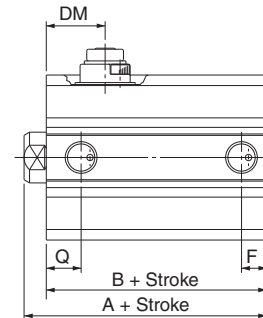

Head end lock

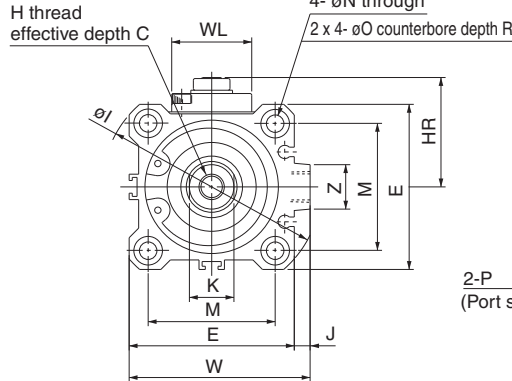
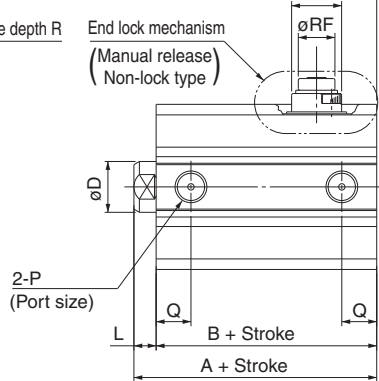

$\phi 63, \phi 80, \phi 100$
Cylinder tube form

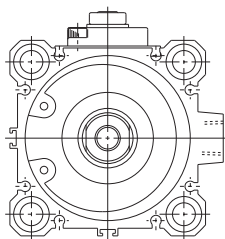

End lock mechanism
(Manual release lock type)

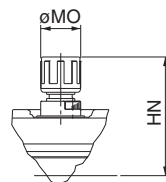

Rod end male thread

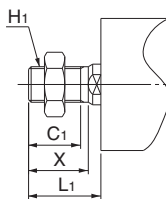

End Lock Mechanism Dimensions

Bore size (mm)	DL	DM	HR	HN (Max.)	LL	MO	WL	RF
32	25	22	33.5	45	15	15	24	11
40	29	26	38.5	52.5	21	19	24	11
50	29.5	24	45	59	21	19	24	11
63	28.5	25	50	64	21	19	24	11
80	45	45.5	62	76.5	30	23	40	21
100	48	49	71.5	86	30	23	40	21

Bore size (mm)	Standard stroke	C ₁	X	H ₁	L ₁
32	10, 15, 20, 25 50, 75, 100	20.5	23.5	M14 x 1.5	28.5
40		20.5	23.5	M14 x 1.5	28.5
50		26	28.5	M18 x 1.5	33.5
63	25, 50 75, 100	26	28.5	M18 x 1.5	33.5
80		32.5	35.5	M22 x 1.5	43.5
100	25, 50	32.5	35.5	M26 x 1.5	43.5
	75, 100				53.5

Bore size (mm)	Standard stroke	C	D	E	H	I	J	K	M	N	O	P	R	W	Z
32	10, 15, 20, 25 50, 75, 100	13	16	45	M8 x 1.25	60	4.5	14	34	5.5	9	Rc 1/8	7	49.5	14
40		13	16	52	M8 x 1.25	69	5	14	40	5.5	9	Rc 1/8	7	57	14
50		15	20	64	M10 x 1.5	86	7	17	50	6.6	11	Rc 1/4	8	71	19
63	25, 50 75, 100	15	20	77	M10 x 1.5	103	7	17	60	9	14	Rc 1/4	10.5	84	19
80		21	25	98	M16 x 2.0	132	6	22	77	11	17.5*	Rc 3/8	13.5*	104	26
100	25, 50 75, 100	27	30	117	M20 x 2.5	156	6.5	27	94	11	17.5*	Rc 3/8	13.5*	123.5	26

* At the 75, and 100 strokes with $\phi 80, 100$, both ends tapped (A) is the standard. Through-hole (B) is not available.

With Head End Lock

Bore size (mm)	Standard stroke	A	B	L	Q
32	10, 15, 20, 25 50, 75, 100	72.5	65.5	7	12.5
40		82	75	7	14
50		83.5	75.5	8	14
63	25, 50 75, 100	85	77	8	15.5
80		121	111	10	18
100	25, 50	136	116	20	19
	75, 100	132.5	120.5	12	22
100	25, 50	147.5	125.5	22	23
	75, 100	147.5	125.5	22	23

With Rod End Lock

Bore size (mm)	Standard stroke	A	B	F	L	Q
32	10, 15, 20, 25 50, 75, 100	65	58	7.5	7	10.5
40		71.5	64.5	8	7	11
50		73.5	65.5	10.5	8	10.5
63	25, 50 75, 100	79	71	10.5	8	15
80		113.5	103.5	12.5	10	16
100	25, 50	136	116	19	20	19
	75, 100	125	113	13	12	23
100	25, 50	147.5	125.5	23	22	23
	75, 100	147.5	125.5	23	22	23

Compact Cylinder with End Lock Series **CBQ2**

Dimensions: $\phi 32$ to $\phi 100$

Foot style: CBQ2L/CDBQ2L

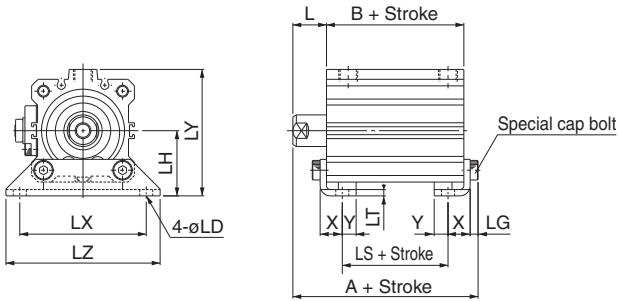

Rod end male thread

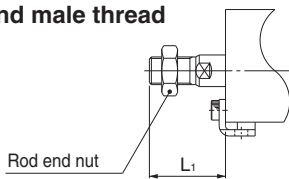

Foot Style

Bore size (mm)	Standard stroke	With head end lock			With rod end lock			L	L ₁	LD
		A	B	LS	A	B	LS			
32		89.7	65.5	49.5	82.2	58	42	17	38.5	6.6
40	10, 15, 20, 25	99.2	75	59	88.7	64.5	48.5	17	38.5	6.6
50	50, 75, 100	101.7	75.5	52.5	91.7	65.5	42.5	18	43.5	9
63		103.2	77	51	97.2	71	45	18	43.5	11
80	25, 50	142.5	111	81	135	103.5	73.5	20	53.5	13
	75, 100	147.5	116	86	147.5	116	86			
100	25, 50	155.5	120.5	86.5	148	113	79	22	53.5	13
	75, 100	160.5	125.5	91.5	160.5	125.5	91.5			

Bore size (mm)	Standard stroke	LG	LH	LT	LX	LY	LZ	X	Y
32		4	30	3.2	57	57	71	11.2	5.8
40	10, 15, 20, 25	4	33	3.2	64	64	78	11.2	7
50	50, 75, 100	5	39	3.2	79	78	95	14.7	8
63		5	46	3.2	95	91.5	113	16.2	9
80	25, 50, 75, 100	7	59	4.5	118	114	140	19.5	11
100		7	71	6	137	136	162	23	12.5

CUJ

CU

CQS

CQM

CQ2

RQ

MU

D-

-X

20-

Data

Rod side flange style: CBQ2F/CDBQ2F

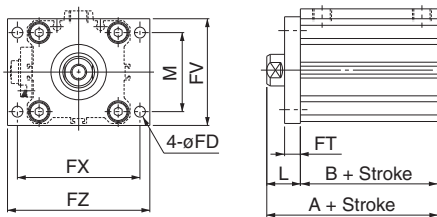

Rod end male thread

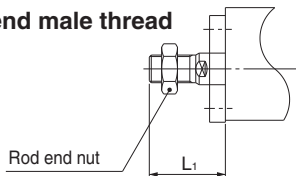

Rod Side Flange Style

Bore size (mm)	Standard stroke	With head end lock		With rod end lock		FD	FT	FV	FX	FZ
		A	B	A	B					
32		82.5	65.5	75	58	5.5	8	48	56	65
40	10, 15, 20, 25	92	75	81.5	64.5	5.5	8	54	62	72
50	50, 75, 100	93.5	75.5	83.5	65.5	6.6	9	67	76	89
63		95	77	89	71	9	9	80	92	108
80	25, 50	131	111	123.5	103.5	11	11	99	116	134
	75, 100	136	116	136	116					
100	25, 50	142.5	120.5	135	113	11	11	117	136	154
	75, 100	147.5	125.5	147.5	125.5					

Bore size (mm)	Standard stroke	L	L ₁	M
32		17	38.5	34
40	10, 15, 20, 25	17	38.5	40
50	50, 75, 100	18	43.5	50
63		18	43.5	60
80	25, 50, 75, 100	20	53.5	77
100		22	53.5	94

Series CBQ2

Dimensions: $\phi 32$ to $\phi 100$

Head side flange style: CBQ2G/CDBQ2G

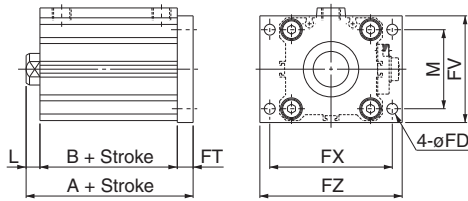

Rod end male thread

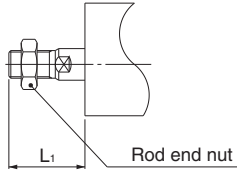

Head Side Flange Style

Bore size (mm)	Standard stroke	With head end lock				With rod end lock			
		A	B	L	L ₁	A	B	L	L ₁
32	10, 15, 20, 25 50, 75, 100	80.5	65.5	7	28.5	73	58	7	28.5
40		90	75	7	28.5	79.5	64.5	7	28.5
50		92.5	75.5	8	33.5	82.5	65.5	8	33.5
63	25, 50 75, 100	94	77	8	33.5	88	71	8	33.5
80		132	111	10	43.5	124.5	103.5	10	43.5
100	25, 50	147	116	20	53.5	147	116	20	53.5
	75, 100	143.5	120.5	12	43.5	136	113	12	43.5
100	25, 50	158.5	125.5	22	53.5	158.5	125.5	22	53.5
	75, 100	158.5	125.5	22	53.5	158.5	125.5	22	53.5

Bore size (mm)	Standard stroke	M	FD	FT	FV	FX	FZ
32	10, 15, 20, 25, 50, 75, 100	34	5.5	8	48	56	65
40		40	5.5	8	54	62	72
50		50	6.6	9	67	76	89
63		60	9	9	80	92	108
80		77	11	11	99	116	134
100	94	11	11	117	136	154	

Double clevis style: CBQ2D/CDBQ2D

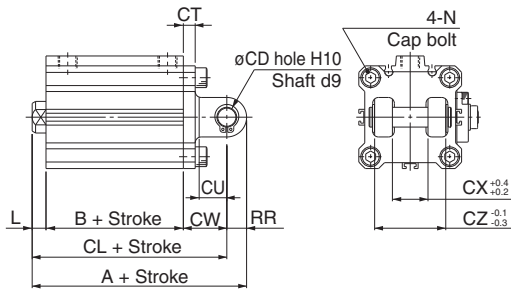

Rod end male thread

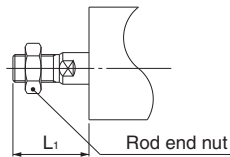

Double Clevis Style

Bore size (mm)	Standard stroke	With head end lock			With rod end lock			CD	CT	CU	L	L ₁
		A	B	CL	A	B	CL					
32	10, 15, 20, 25 50, 75, 100	102.5	65.5	92.5	95	58	85	10	5	14	7	28.5
40		114	75	104	103.5	64.5	93.5	10	6	14	7	28.5
50		125.5	75.5	111.5	115.5	65.5	101.5	14	7	20	8	33.5
63	25, 50 75, 100	129	77	115	123	71	109	14	8	20	8	33.5
80		177	111	159	169.5	103.5	151.5	18	10	27	10	43.5
100	25, 50	192	116	174	192	116	174	22	13	31	20	53.5
	75, 100	199.5	120.5	177.5	192	113	170	22	13	31	12	43.5
100	25, 50	214.5	125.5	192.5	214.5	125.5	192.5	22	13	31	22	53.5
	75, 100	214.5	125.5	192.5	214.5	125.5	192.5	22	13	31	22	53.5

Bore size (mm)	Standard stroke	CW	CX	CZ	N	RR
32	10, 15, 20, 25 50, 75, 100	20	18	36	M6 x 1.0	10
40		22	18	36	M6 x 1.0	10
50		28	22	44	M8 x 1.25	14
63	25, 50, 75, 100	30	22	44	M10 x 1.5	14
80		38	28	56	M12 x 1.75	18
100	45	32	64	M12 x 1.75	22	

Compact Cylinder with End Lock Series **CBQ2**

Allowable Kinetic Energy

With Rubber Bumper

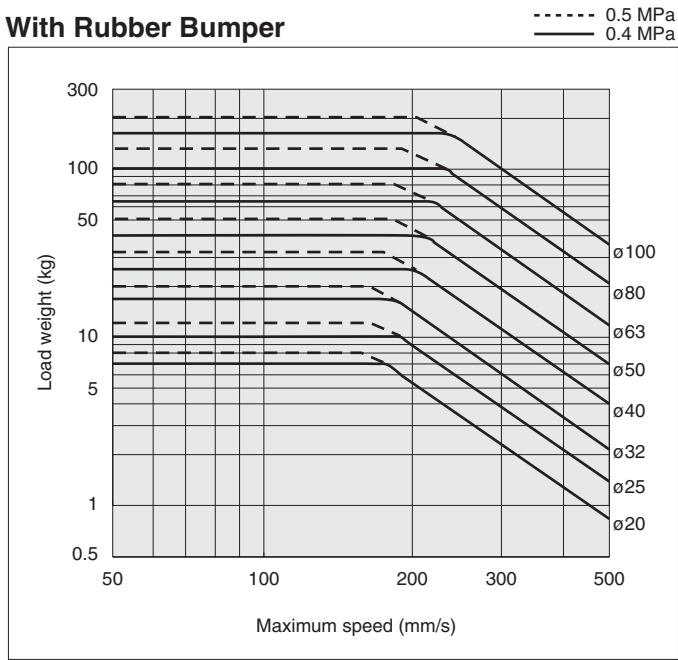

Allowable Lateral Load at Rod End

With Auto Switch (Anti-lateral load)

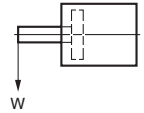
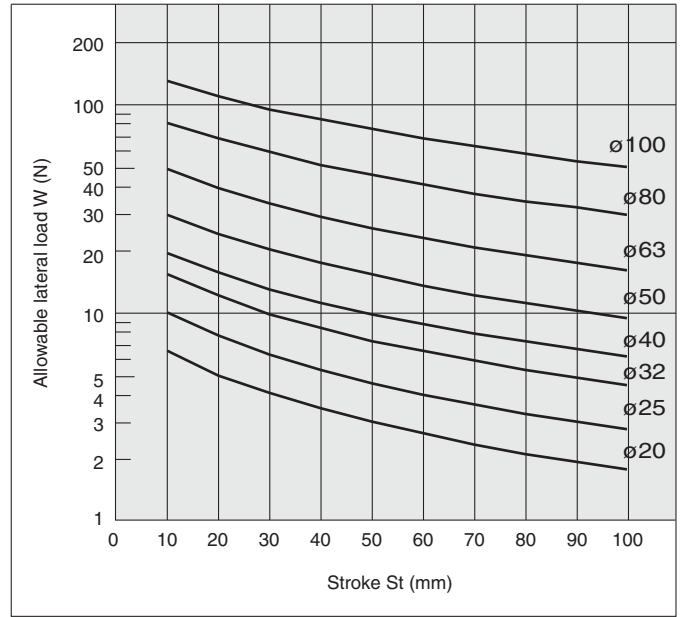

(Mounting orientation: Horizontal)

- CUJ
- CU
- CQS
- CQM
- CQ2**
- RQ
- MU
- D-
- X
- 20-
- Data

