

# Fine Lock Cylinder

## Double Acting, Single Rod

# CLJ2 Series

ø16

### How to Order

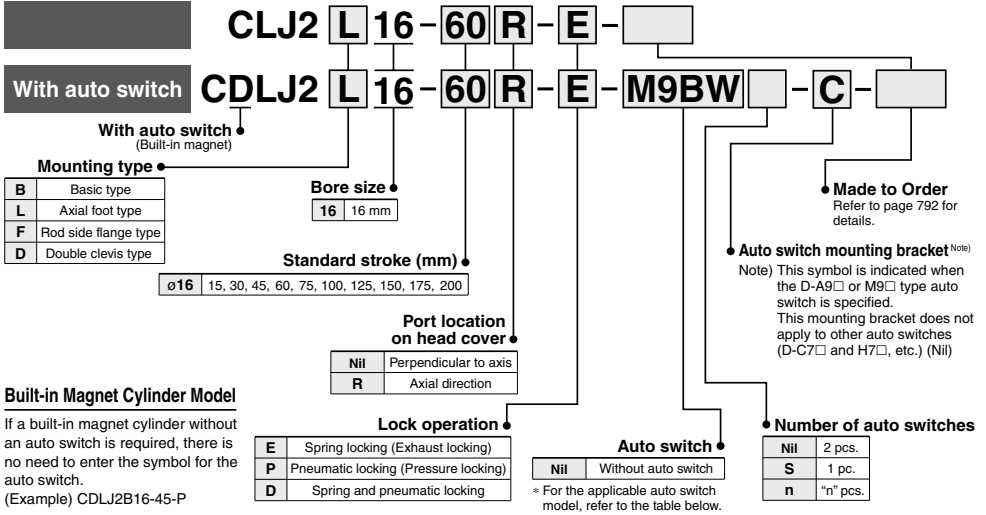

### Applicable Auto Switches

Refer to pages 1119 to 1245 for further information on auto switches.

Type	Special function	Electrical entry	Indicator light	Wiring (Output)	Load voltage		Auto switch model				Lead wire length (m)				Pre-wired connector	Applicable load	
					DC	AC	Band mounting		Rail mounting		0.5 (Nil)	1 (M)	3 (L)	5 (Z)			None (N)
							Perpendicular	In-line	Perpendicular	In-line							
Solid state auto switch	—	Grommet	Yes	3-wire (NPN)	5 V, 12 V	—	M9NV	M9N	M9NV	M9N	●	●	●	○	○	IC circuit	
				3-wire (PNP)			M9PV	M9P	M9PV	M9P	●	●	●	○	○		
		Connector		2-wire	M9BV	M9B	M9BV	M9B	●	●	●	○	○	—			
				—	H7C	J79C	—	●	●	●	●	—	—				
	Diagnostic indication (2-color indicator)	Grommet	Yes	3-wire (NPN)	5 V, 12 V	—	M9NVW	M9NW	M9NVW	M9NW	●	●	●	○	○	IC circuit	
				3-wire (PNP)			M9PVW	M9PW	M9PVW	M9PW	●	●	●	○	○		
	Water resistant (2-color indicator)	Grommet		2-wire	5 V, 12 V	—	M9BWW	M9BW	M9BWW	M9BW	●	●	●	○	○	IC circuit	
				3-wire (NPN)			M9NAV*1	M9NA*1	M9NAV*1	M9NA*1	○	○	●	○	○		
	With diagnostic output (2-color indicator)	Grommet	Yes	3-wire (PNP)	5 V, 12 V	—	M9PAV*1	M9PA*1	M9PAV*1	M9PA*1	○	○	●	○	○	IC circuit	
				2-wire			M9BAV*1	M9BA*1	M9BAV*1	M9BA*1	○	○	○	○	○		
Connector				4-wire (NPN)	5 V, 12 V	—	H7NF	F79F	●	—	●	○	○	IC circuit			
				—			—	—	—	—	—	—	—		—		
Reed auto switch	—	Grommet	Yes	3-wire (NPN equivalent)	5 V	—	A96V	A96	A96V	A96	●	—	●	—	—	IC circuit	
							—	200 V	—	A72	A72H	●	—	●	—		—
		Connector		2-wire	100 V	A93V*2	A93	A93V*2	A93	●	●	●	●	—	—	—	
					100 V or less	A90V	A90	A90V	A90	●	●	●	●	—	IC circuit		
	Diagnostic indication (2-color indicator)	Grommet	Yes	No (Res/No)	2-wire	24 V	12 V	—	C73C	A73C	—	●	—	●		●	—
								—	C80C	A80C	—	●	—	●	●		
								24 V or less	—	A79W	—	●	—	●	●		
								—	—	—	—	●	—	●	●		

\*1 Water resistant type auto switches can be mounted on the above models, but in such case SMC cannot guarantee water resistance. Consult with SMC regarding water resistant types with the above model numbers.

\*2 1 m type lead wire is only applicable to D-A93.

\* Lead wire length symbols: 0.5 m ..... Nil (Example) M9NW  
1 m ..... M (Example) M9NWM  
3 m ..... L (Example) M9NWL  
5 m ..... Z (Example) M9NWZ  
None ..... N (Example) H7CN

\* Since there are other applicable auto switches than listed, refer to page 800 for details.

\* For details about auto switches with pre-wired connector, refer to pages 1192 and 1193.

\* Solid state auto switches marked with "□" are produced upon receipt of order.

\* The D-A9□, M9□, M9□W, A7□□, A80□, A80□, F7□□, J7□□ auto switches are shipped together, (but not assembled). (However, only the auto switch mounting brackets are assembled for band mounting before shipment.)



CLJ2

CLM2

CLG1

CL1

MLGC

CNG

MNB

CNA2

CNS

CLS

CLQ

RLQ

MLU

MLGP

ML1C

D-□

-X□

# CLJ2 Series

**Provided with a compact lock mechanism, it is suitable for intermediate stop, emergency stop, and drop prevention.**

## Locking in both directions

The piston rod can be locked in either direction of its cylinder stroke.

## Maximum piston speed: 500 mm/s

It can be used at 50 to 500 mm/s provided that it is within the allowable kinetic energy range.

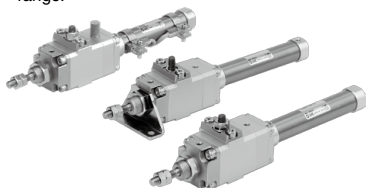

## Head Cover Port Location

Either perpendicular to the cylinder axis or in-line with the cylinder axis is available for basic type.



Axial



Perpendicular



## Made to Order Specifications

[Click here for details](#)

Symbol	Specifications
-XA□	Change of rod end shape

Refer to pages 798 to 800 for cylinders with auto switches.

- Minimum auto switch mounting stroke
- Proper auto switch mounting position (detection at stroke end) and mounting height
- Operating range
- Switch mounting bracket: Part no.

## Specifications

Bore size (mm)	16
Action	Double acting, Single rod
Lubricant	Not required (Non-lube)
Lock operation	Spring locking (Exhaust locking) Pneumatic locking (Pressure locking) Spring and pneumatic locking
Fluid	Air
Proof pressure	1.05 MPa
Maximum operating pressure	0.7 MPa
Minimum operating pressure	0.08 MPa
Ambient and fluid temperature	Without auto switch: -10 to 70°C (No freezing) With auto switch: -10 to 60°C (No freezing)
Piston speed	50 to 500 mm/s *
Cushion	Rubber bumper
Stroke length tolerance	$\begin{matrix} +1.0 \\ 0 \end{matrix}$
Mounting	Basic type, Axial foot type, Rod side flange type, Double clevis type

\* Constraints associated with the allowable kinetic energy are imposed on the speeds at which the piston can be locked.  
The maximum speed of 750 mm/s can be accommodated if the piston is to be locked in the stationary state for the purpose of drop prevention.

## Fine Lock Specifications

Lock operation	Spring locking (Exhaust locking)	Spring and pneumatic locking	Pneumatic locking (Pressure locking)
Fluid	Air		
Maximum operating pressure	0.5 MPa		
Unlocking pressure	0.3 MPa or more		0.1 MPa or more
Lock starting pressure	0.25 MPa or less		0.05 MPa or more
Locking direction	Both directions		

## Standard Stroke

Refer to the minimum auto switch mounting stroke (page 799) for those with an auto switch. (mm)

Bore size (mm)	Standard stroke
16	15, 30, 45, 60, 75, 100, 125, 150, 175, 200

\* Manufacture of intermediate strokes at 1 mm intervals is possible. (Spacers are not used.)

## Mounting Bracket and Accessory

For details about part numbers and dimensions, refer to page 797.

Mounting		Basic type	Axial foot type	Rod side flange type	Double clevis type
Standard equipment	Mounting nut	●	●	●	—
	Rod end nut	●	●	●	●
	Clevis pin	—	—	—	●
Option	Single knuckle joint	●	●	●	●
	Double knuckle joint (With pin) *	●	●	●	●
	T-bracket	—	—	—	●

\* Pins and retaining rings are packaged together with double clevis and double knuckle joint.

## Mounting Bracket Part No.

Mounting bracket	Part no.
Foot	CLJ-L016B
Flange	CLJ-F016B
T-bracket *	CJ-T016B

\* T-bracket is used with double clevis (D).

### Weight

(g)

Bore size (mm)		<b>16</b>
Standard weight *		320
Additional weight per each 15 mm of stroke		6.5
Mounting bracket Weight	Axial foot type	27
	Rod side flange type	21
	Double clevis type (With pin) **	10

\* Mounting nut and rod end nut are included in the basic weight.

\*\* Mounting nut is not included in double clevis type.

Calculation: (Example) **CLJ2L16-60**

- Basic weight.....320 (ø16)
- Additional weight.....6.5/15 stroke
- Cylinder stroke.....60 stroke  
320 + 6.5/15 x 60 + 27 = 373 g

### Stopping Accuracy (Not including tolerance of control system.) (mm)

Lock type	Piston speed (mm/s)			
	50	100	300	500
Spring locking (Exhaust locking)	± 0.4	± 0.5	± 1.0	± 2.0
Pneumatic locking (Pressure locking) Spring and pneumatic locking	± 0.2	± 0.3	± 0.5	± 1.5

Condition: Load: 2 kg

Solenoid valve: Lock port mounting

### ⚠ Caution

Selection/Recommended Pneumatic Circuit/Caution on Handling

For detailed specifications of the fine lock cylinder, CLJ2 series mentioned above, refer to pages 786 to 789.

### ⚠ Caution/Allowable Kinetic Energy when Locking

Bore size (mm)	<b>16</b>
Allowable kinetic energy (J)	0.17

- In terms of specific load conditions, this allowable kinetic energy is equivalent to a load of 3.7 kg in mass, and a piston speed of 300 mm/sec. Therefore, if the operating conditions are below these values, there is no need to calculate.
- Apply the following formula to obtain the kinetic energy of the load.  

$$E_k = \frac{1}{2} m v^2$$

$$E_k: \text{Kinetic energy of load (J)}$$

$$m: \text{Load mass (kg)}$$

$$v: \text{Piston speed (m/s)}$$
- The piston speed will exceed the average speed immediately before locking. To determine the piston speed for the purpose of obtaining the kinetic energy of load, use 1.2 times the average speed as a guide.
- The relationship between the speed and the load is indicated in the graph below. The area below the line is the allowable kinetic energy range.
- There is an upper limit to the size of the load that can be sustained. Thus, a horizontally mounted cylinder must be operated below the solid line, and a vertically mounted cylinder must be operated below the dotted line.

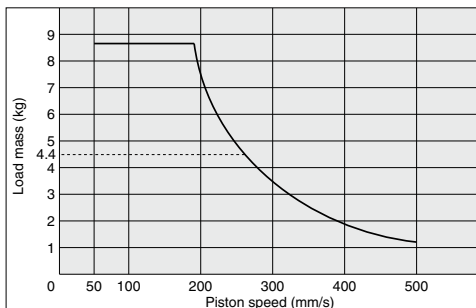

### Holding Force of Spring Locking (Maximum static load)

Bore size (mm)	<b>16</b>
Holding force (N)	122

(Note) Holding force at piston rod extended side decreases approximately 15%.

### Holding Force of Pneumatic Locking (Maximum static load)

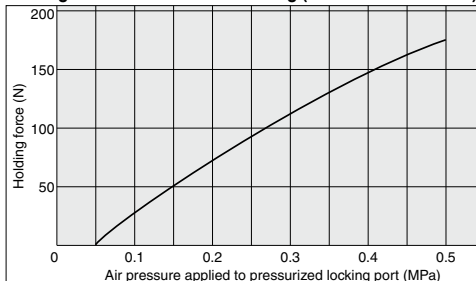

\* When selecting cylinders, refer to the Precautions and allowable kinetic energy when locking on page 786, and then select a cylinder.

### ⚠ Caution

#### Caution when Locking

Holding force (maximum static load) means the maximum capability of holding a static load that is not accompanied by vibration or impact under the condition that no load is applied. Therefore, it does not refer to a load that cannot be held constantly.

When using (selecting) this product, carefully check the following points.

- If the piston rod slips because the lock's holding force has been exceeded, the brake shoe could be damaged, resulting in a reduced holding force or shortened life.
- The upper limit of the load that is used under the conditions not associated with the kinetic energy when locking, such as drop prevention must be 35% or less of the holding force.
- Do not use the cylinder in the locked state to sustain a load that involves impact.

CLJ2

CLM2

CLG1

CL1

MLGC

CNG

MNB

CNA2

CNS

CLS

CLQ

RLQ

MLU

MLGP

ML1C

D-□

-X□

# CLJ2 Series

## Construction (Not able to disassemble)

### Spring locking (Exhaust locking) Spring and pneumatic locking

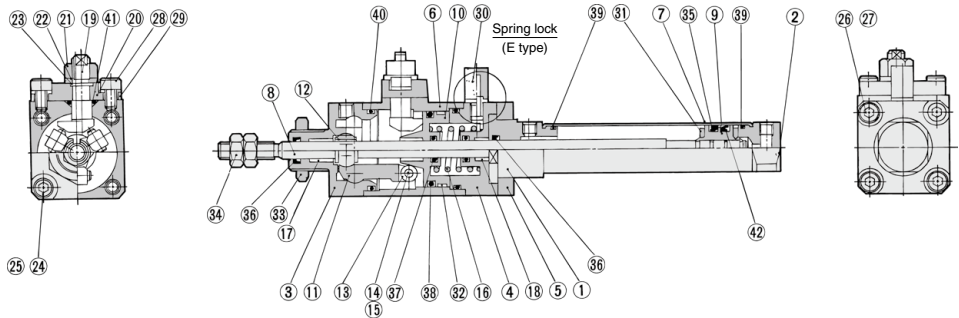

### Pneumatic locking (Pressure locking)

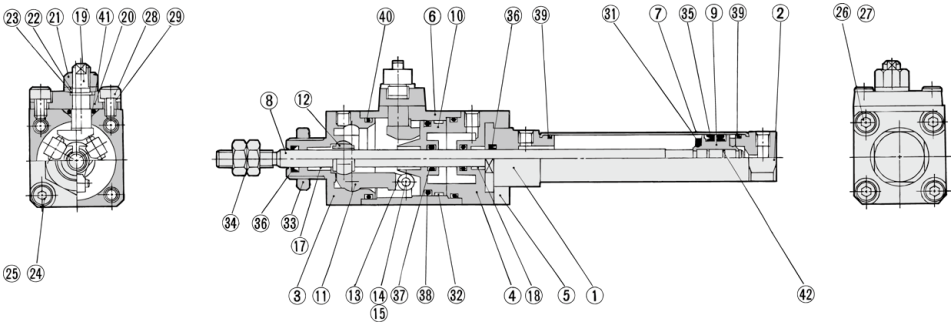

### Component Parts

No.	Description	Material	Note
1	Rod cover	Aluminum alloy	Clear anodized
2	Head cover	Aluminum alloy	Clear anodized
3	Cover A	Carbon steel	Nitrided, nickel chrome plated
4	Cover B	Aluminum alloy	Hard anodized
5	Cover C	Aluminum alloy	Hard anodized
6	Intermediate cover	Aluminum alloy	Hard anodized
7	Cylinder tube	Stainless steel	
8	Piston rod	Stainless steel	Hard chrome plated
9	Piston	Aluminum alloy	Chromated
10	Brake piston	Carbon steel	Nitrided
11	Brake arm	Carbon steel	Nitrided
12	Brake shoe	Special friction material	
13	Roller	Carbon steel	Nitrided
14	Pin	Carbon steel	Heat treated
15	Retaining ring	Carbon tool steel	
16	Brake spring	Steel wire	Zinc chromated
17	Bushing A	Bearing alloy	
18	Bushing B	Bearing alloy	
19	Manual lock release cam	Chromium molybdenum steel	Nitrided
20	Cam guide	Carbon steel	Nitrided, platinum silver painted
21	Lock nut	Rolled steel	

No.	Description	Material	Note
22	Plain washer	Rolled steel	
23	Retaining ring	Carbon tool steel	
24	Hexagon socket head cap screw	Chromium molybdenum steel	
25	Spring washer	Steel wire	
26	Hexagon socket head cap screw	Chromium molybdenum steel	
27	Spring washer	Steel wire	
28	Hexagon socket head cap screw	Chromium molybdenum steel	
29	Spring washer	Steel wire	
30	Silencer	Bronze	Type E only
31	Bumper	Urethane	
32	Wear ring	Resin	
33	Mounting nut	Brass	
34	Rod end nut	Rolled steel	
35	Piston seal	NBR	
36	Rod seal A	NBR	
37	Rod seal B	NBR	
38	Brake piston seal	NBR	
39	Cylinder tube gasket	NBR	
40	Intermediate cover gasket	NBR	
41	Cam gasket	NBR	
42	Piston gasket	NBR	

**Basic Type (B)**

CLJ2B16-□□-□<sup>FE</sup>-□<sub>P</sub>

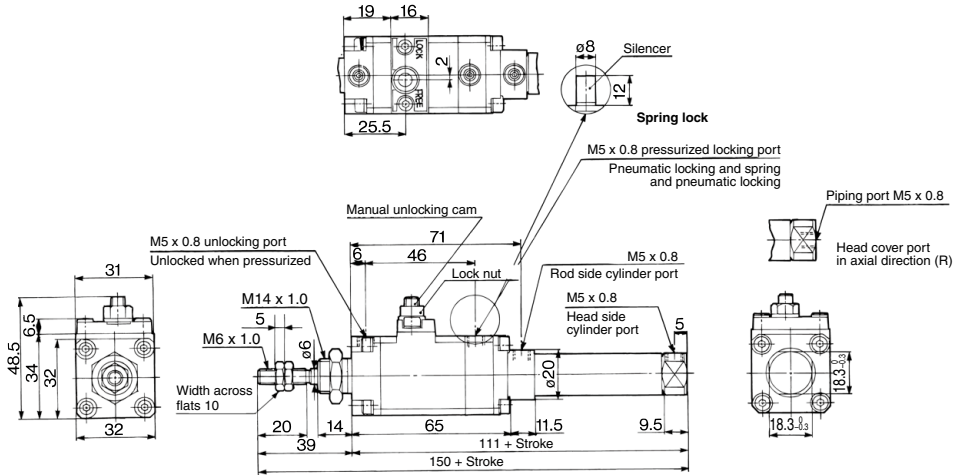

**Axial Foot Type (L)**

CLJ2L16-□□-□<sup>FE</sup>-□<sub>P</sub>

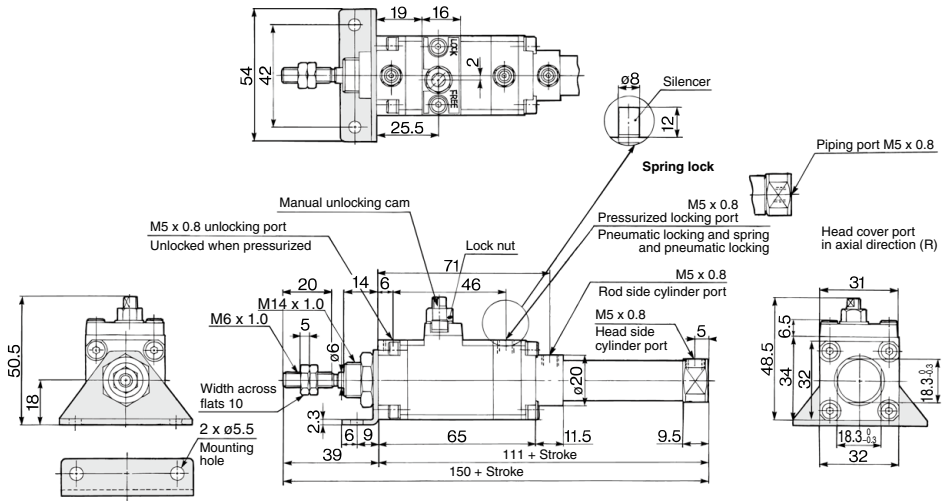

CLJ2
CLM2
CLG1
CL1
MLGC
CNG
MNB
CNA2
CNS
CLS
CLQ
RLQ
MLU
MLGP
ML1C

D-□
-X□

# CLJ2 Series

## Rod Side Flange Type (F)

CLJ2F16-□□- $\frac{F}{P}$

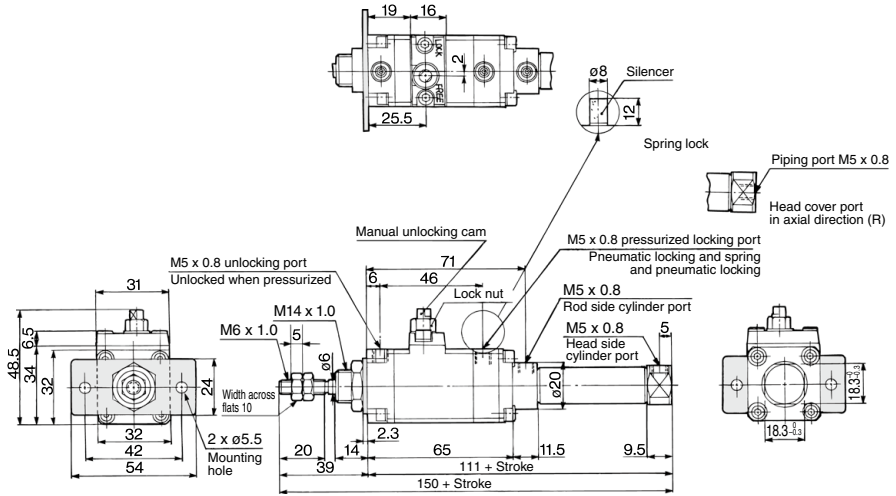

## Double Clevis Type (D) \* Clevis pin and retaining ring are shipped together.

CLJ2D16-□□- $\frac{F}{P}$

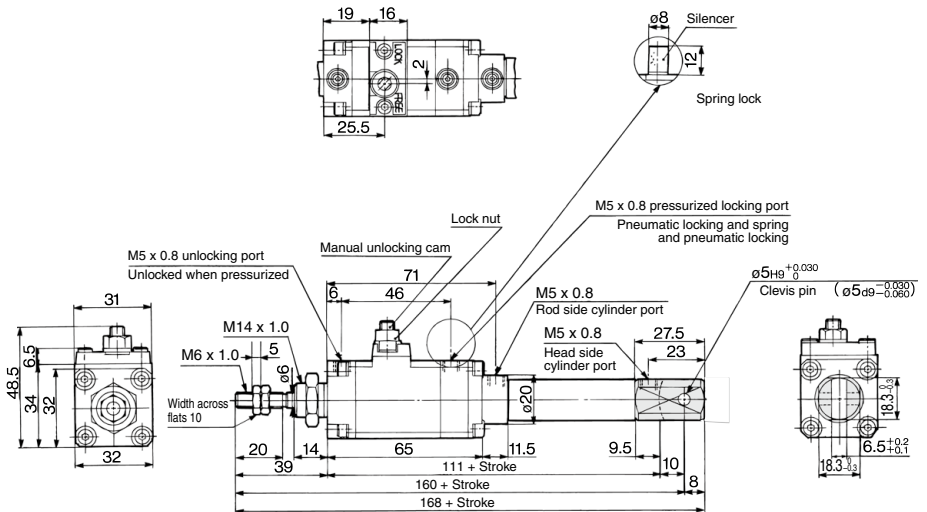

## Accessory Bracket Dimensions

### Single Knuckle Joint: I-LJ016B

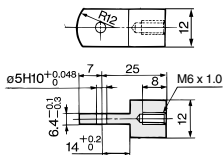

Material: Rolled steel

### Double Knuckle Joint: Y-LJ016B

\* Knuckle pin and retaining ring are shipped together.

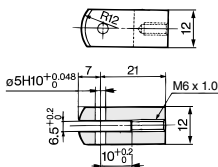

Material: Rolled steel

### Rod End Nut: NT-015A

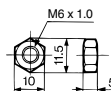

Material: Rolled steel

### Clevis Pin: CD-Z015

\* Retaining rings are shipped together.

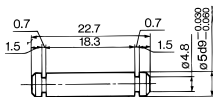

Material: Stainless steel

### Knuckle Pin: IY-J015A

\* Retaining rings are shipped together.

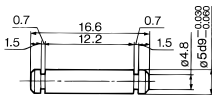

Material: Stainless steel

### Mounting Nut: SNLJ-016B

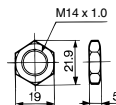

Material: Brass

### T-bracket: CJ-T016B

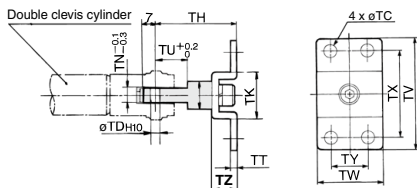

Material: Rolled steel

Part no.	Bore size (mm)	TC	TDH10	TH	TK	TN	TT	TU	TV	TW	TX	TY	TZ
<b>CJ-T016B</b>	<b>16</b>	5.5	5 <sup>+0.048</sup>	35	20	6.4	2.3	14	48	28	38	16	10

\* T-bracket includes a T-bracket base, single knuckle joint, hexagon socket head cap screw and spring washer.

CLJ2

CLM2

CLG1

CL1

MLGC

CNG

MNB

CNA2

CNS

CLS

CLQ

RLQ

MLU

MLGP

ML1C

D-□

-X□

# Auto Switch Mounting 1

## Auto Switch Proper Mounting Position (Detection at Stroke End) and Its Mounting Height

### Reed auto switch <Band Mounting>

D-A9□

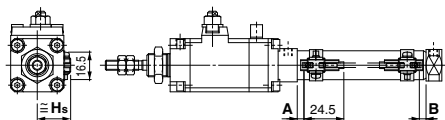

( ) : For D-A96

D-C7□/C80

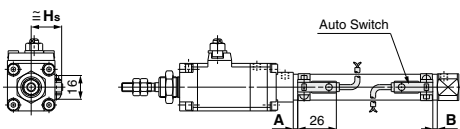

D-C73C□/C80C

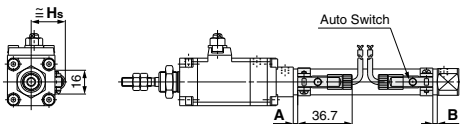

### Solid state auto switch <Band Mounting>

D-M9□  
D-M9□A  
D-M9□W

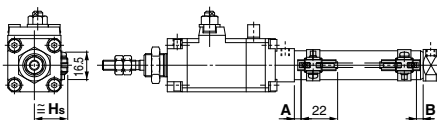

( ) : For D-M9□A

D-H7□  
D-H7□W  
D-H7BA  
D-H7NF

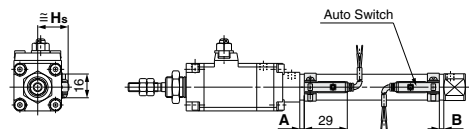

D-H7C

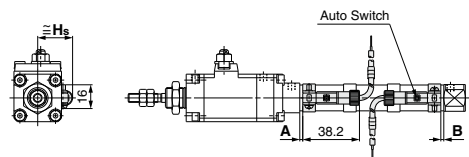

## Auto Switch Proper Mounting Position (Detection at Stroke End) and Its Mounting Height

### Auto Switch Proper Mounting Position

(mm)

Auto switch model	D-M9□(V) D-M9□W(V) D-M9□A(V)		D-A9□(V)		D-C7/C8 D-C73C D-C80C		D-H7□ D-H7C D-H7□W D-H7BA D-H7NF	
	A	B	A	B	A	B	A	B
Bore size (mm) <b>16</b>	6.5	6.5	2.5	2.5	3	3	2	2

Note) Adjust the auto switch after confirming the operating conditions in the actual setting.

### Auto Switch Mounting Height

(mm)

Auto switch model	D-M9□(V) D-M9□W(V) D-M9□A(V) D-A9□(V)		D-C7/C8 D-H7□ D-H7□W D-H7NF D-H7BA		D-C73C D-C80C		D-H7C	
	Hs		Hs		Hs		Hs	
Bore size (mm) <b>16</b>	21		20.5		23		23.5	



**Minimum Auto Switch Mounting Stroke**

		(mm)				
Auto switch mounting	Auto switch model	No. of auto switches mounted				
		1	2		n (n: No. of auto switches)	
			Different surfaces	Same surface	Different surfaces	Same surface
Band mounting	D-M9□ D-M9□W D-M9□A D-A9□	10	15 <small>Note 1</small>	45 <small>Note 1</small>	$15 + 35 \frac{(n-2)}{2}$ <small>(n = 2, 4, 6...)</small> <small>Note 3</small>	$45 + 15 (n - 2)$ <small>(n = 2, 3, 4, 5...)</small>
	D-M9□V	5	15 <small>Note 1</small>	35	$15 + 35 \frac{(n-2)}{2}$ <small>(n = 2, 4, 6...)</small> <small>Note 3</small>	$35 + 25 (n - 2)$ <small>(n = 2, 3, 4, 5...)</small>
	D-M9□WV D-M9□AV	10	15 <small>Note 1</small>	35	$15 + 35 \frac{(n-2)}{2}$ <small>(n = 2, 4, 6...)</small> <small>Note 3</small>	$35 + 25 (n - 2)$ <small>(n = 2, 3, 4, 5...)</small>
	D-A9□V	5	10	35	$10 + 35 \frac{(n-2)}{2}$ <small>(n = 2, 4, 6...)</small> <small>Note 3</small>	$35 + 25 (n - 2)$ <small>(n = 2, 3, 4, 5...)</small>
	D-C7□ D-C80	10	15	50	$15 + 40 \frac{(n-2)}{2}$ <small>(n = 2, 4, 6...)</small> <small>Note 3</small>	$50 + 20 (n - 2)$ <small>(n = 2, 3, 4, 5...)</small>
	D-H7□/H7□W D-H7BA D-H7NF	10	15	60	$15 + 45 \frac{(n-2)}{2}$ <small>(n = 2, 4, 6...)</small> <small>Note 3</small>	$60 + 22.5 (n - 2)$ <small>(n = 2, 3, 4, 5...)</small>
	D-C73C D-C80C D-H7C	10	15	65	$15 + 50 \frac{(n-2)}{2}$ <small>(n = 2, 4, 6...)</small> <small>Note 3</small>	$50 + 27.5 (n - 2)$ <small>(n = 2, 3, 4, 5...)</small>

Note 3) When "n" is an odd number, an even number that is one larger than this odd number is used for the calculation.

Note 1) Auto switch mounting.

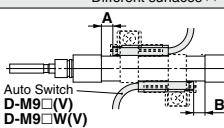
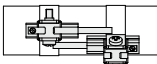
Auto switch model	With 2 auto switches	
	Different surfaces <sup>(1)</sup>	Same surface <sup>(1)</sup>
	 <p>Auto Switch D-M9□(V) D-M9□W(V) D-M9□A(V)</p> <p>The proper auto switch mounting position is 5.5 mm inward from the switch holder edge. The above A and B indicate values for band mounting in the table of page 798</p>	 <p>The auto switch is mounted by slightly displacing it in a direction (cylinder tube circumferential exterior) so that the auto switch and lead wire do not interfere with each other.</p>
D-M9□/M9□W/M9□A	Less than 20 stroke <small>Note 2</small>	Less than 55 stroke <small>Note 2</small>
D-A90/A93	—	Less than 50 stroke <small>Note 2</small>

Note 2) Minimum stroke for auto switch mounting in types other than those mentioned in Note 1.

**Operating Range**

Auto switch model	(mm)
	Bore size (mm)
	<b>16</b>
D-A9□	7
D-M9□ D-M9□W	3
D-C7□/C80 D-C73C/C80C	7
D-H7□/H7□W/H7BA/H7NF	4
D-H7C	9

\* Since the operating range is provided as a guideline including hysteresis, it cannot be guaranteed (assuming approximately ±30% dispersion). It may vary substantially depending on an ambient environment.

- CLJ2
- CLM2
- CLG1
- CL1
- MLGC
- CNG
- MNB
- CNA2
- CNS
- CLS
- CLQ
- RLQ
- MLU
- MLGP
- ML1C

- D-□
- X□

# Auto Switch Mounting 2

## Auto Switch Mounting Bracket: Part No.

Auto switch mounting	Auto switch model	Bore size (mm)	
		10	16
Band mounting	D-M9□ D-M9□V D-M9□W D-M9□WV D-A9□ D-A9□V	Note 1) BJ6-010	Note 1) BJ6-016
	D-M9□A D-M9□AV	Note 2) BJ6-010S	Note 2) BJ6-016S
	D-C7□/C80 D-C73C/C80C D-H7□/H7□W D-H7BA/H7NF	BJ2-010	BJ2-016

Note 1) Set part number which includes the auto switch mounting band (BJ2-□□□) and the holder kit (BJ5-1/Switch bracket: Transparent). Since the switch bracket (made from nylon) are affected in an environment where alcohol, chloroform, methylamines, hydrochloric acid or sulfuric acid is splashed over, so it cannot be used. Please consult SMC regarding other chemicals.

Note 2) Set part number which includes the auto switch mounting band (BJ2-□□□S) and the holder kit (BJ4-1/Switch bracket: White).

Note 3) For the D-M9□A (V) type auto switch, do not install the switch bracket on the indicator light.

### [Mounting screw set made of stainless steel]

The following set of mounting screws made of stainless steel is available. Use it in accordance with the operating environment. (Please order the auto switch mounting bracket separately, since it is not included.)

BBA4: For D-C7/C8/H7 types

Note 2) Refer to page 1226 for the details of BBA4.

D-H7BAL auto switch is set on the cylinder with the stainless steel screws above when shipped. When an auto switch is shipped independently, BBA4 is attached.

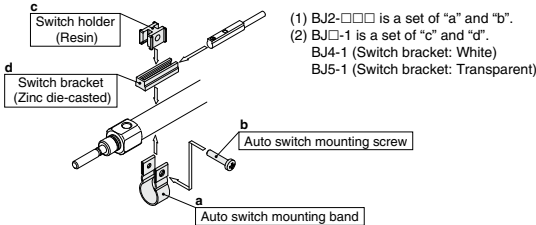

Besides the models listed in How to Order, the following auto switches are applicable. Refer to pages 1119 to 1245 for the detailed specifications.

Auto switch type	Part no.	Electrical entry (Fetching direction)	Features
Reed	D-C73, C76	Grommet (In-line)	—
	D-C80		Without indicator light
Solid state	D-H7A1, H7A2, H7B		—
	D-H7NW, H7PW, H7BW		Diagnostic indication (2-color indicator)

\* For solid state auto switches, auto switches with a pre-wired connector are also available. Refer to pages 1192 and 1193 for details.

\* Normally closed (NC = b contact) solid state auto switches (D-M9□E(V)) are also available. Refer to page 1592-1 for details.