

Vacuum Ejector with Solid State Timer

Series ZMA



Incorporates solid state timer function for release valve control (Timer setting with PLC is unnecessary)

Allows sharing of switch/valve power supply, and single line for suction signal (Valve wiring is unnecessary)

Timing Chart

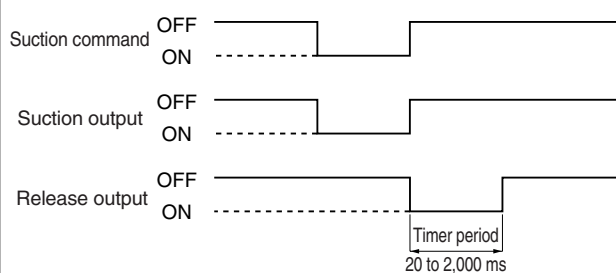

Note) When power is supplied, release output is performed once for the time period only.

Timer can be easily adjusted without programming (Reduction of the load of PLC)

ZA

ZX

ZR

ZM

ZMA

ZQ

ZH

ZU

ZL

ZY□

ZF□

ZP□

SP

ZCUK

AMJ

AMV

AEP

HEP

Related Equipment

Vacuum Ejector With Solid State Timer Series ZMA

How to Order

ZMA 07 1 H [] -K 5 -T14 C -L

Nozzle diameter

05	0.5 mm
07	0.7 mm
10	1.0 mm
13	1.3 mm
15	1.5 mm

Body type

1	For single unit
3 ^{Note)}	Common SUP for manifold
5 ^{Note)}	Individual SUP for manifold

Note) When the product is used for the manifold, the exhaust air of the operating ejector may enter the vacuum port (V) of the non-operating ejector and be released if there are an operating and non-operating ejector. In order to reduce the exhaust intrusion, consider using a special double check valve (-X107).

Standard supply pressure

M	0.35 MPa
S	0.45 MPa
H	0.5 MPa

* Refer to "Table (1)" for selection of standard supply pressure and nozzle diameter.

Release flow rate adjusting needle

Nil	Without lock nut
L	With lock nut

Electrical entry of vacuum switch (Connector type)

C	Lead wire length 0.6 m
CL	Lead wire length 3 m
CN	Without lead wire

* Refer to "Table (2)" for lead wire with 4-wire connector.

Switch model

T14	1 point setting, No analog output available 3 turns, NPN output
T54	1 point setting, No analog output available 3 turns, PNP output

Solenoid valve rated voltage

5	24 VDC
---	--------

Valve

K	With air supply valve, Vacuum release valve
---	---

Thread type

Nil	Rc
T	NPTF
F	G*

* G thread
The thread ridge shape is compatible with the G thread standard (JIS B0203), but other shapes are not conforming to ISO16030 and ISO1179.

**Table (1)
Combination of Nozzle Diameter and Standard Supply Pressure**

Nozzle diameter	Standard supply pressure (MPa)		
	M (0.35)	S (0.45)	H (0.5)
0.5 mm	—	—	●
0.7 mm	●	—	●
1.0 mm	●	—	●
1.3 mm	●	●	●
1.5 mm	—	●	—

Table (2)

Lead wire with 4-wire connector	P5022-6-1 (0.6 m)
	P5022-6-2 (3 m)

Vacuum Ejector *Series ZMA*

With Solid State Timer

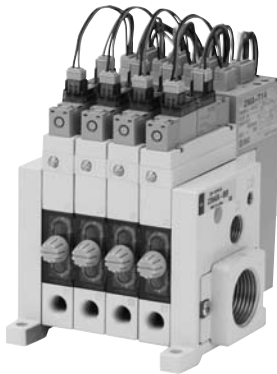

Model

Nozzle diameter (mm)	Model	Standard supply pressure			Maximum suction flow rate ℓ/min (ANR)	Air consumption ℓ/min (ANR)	Diffuser construction
		H	M	S			
0.5	ZMA05 □ H	0.5 MPa	—	—	15	17	Double diffuser
0.7	ZMA07 □ H				30	30	
1.0	ZMA10 □ H				50	60	
1.3	ZMA13 □ H				66	90	
0.7	ZMA07 □ M	—	0.35 MPa	—	23	33	
1.0	ZMA10 □ M				38	60	
1.3	ZMA13 □ M				44	85	
1.3	ZMA13 □ S	—	—	0.45 MPa	37	88	Single diffuser
1.5	ZMA15 □ S				45	110	

Vacuum Ejector Specifications

Fluid	Air
Max. operating pressure	0.7 MPa
Max. vacuum pressure	-84 kPa
Supply pressure range	0.25 to 0.55 MPa
Operating temperature range	5 to 50°C
Suction filter	Polyethylene sintered metal (30 μm)

Valve Specifications

How to operate	Pilot type
Main valve	Poppet
Effective area (Cv factor)	3 mm ² (0.17)
Operating pressure range	0.25 to 0.6 MPa
Electrical entry	Plug connector
Max. operating frequency	5 Hz
Voltage	24 VDC

Vacuum Switch with Timer Specifications (for controlling solenoid valve)

Power source	Operating voltage	24 VDC $\pm 10\%$
	Consumption current per one unit	1.1 W (at switch output OFF)
Sensor switch output	Number of output	1
	Output	NPN/PNP open collector
	Setting trimmer	3 turns
	Operation indicator light	Red LED lighting
	Temperature characteristics	$\pm 3\%$ FS or less
Part of timer	Hysteresis	3% FS or less (fixed)
	Timer period	20 to 2,000 ms
	Setting trimmer	3 turns
	Temperature characteristics	$\pm 3\%$ FS or less

Connection Example

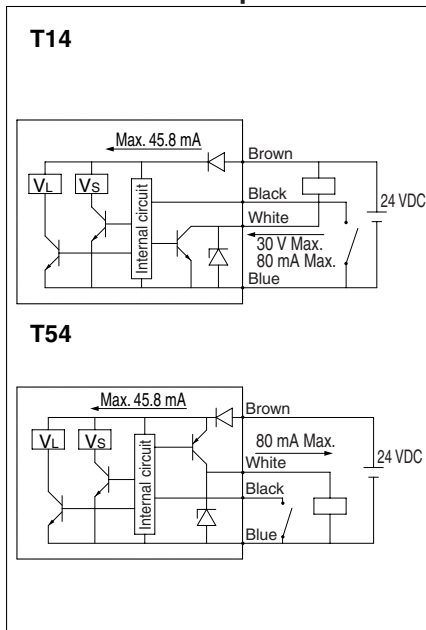

Vl: Pilot valve for release
Vs: Pilot valve for supply

Timing Chart

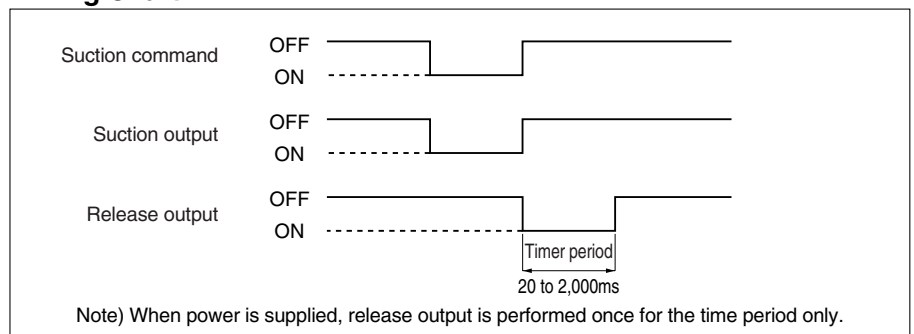

Wiring

Brown	DC (+)
Black	Suction command
White	Switch output
Blue	DC (-)

ZA

ZX

ZR

ZM

ZMA

ZQ

ZH

ZU

ZL

ZY □

ZF □

ZP □

SP

ZCUK

AMJ

AMV

AEP

HEP

Related Equipment

Series ZMA

Construction: ZMA□1□-K□L-E□

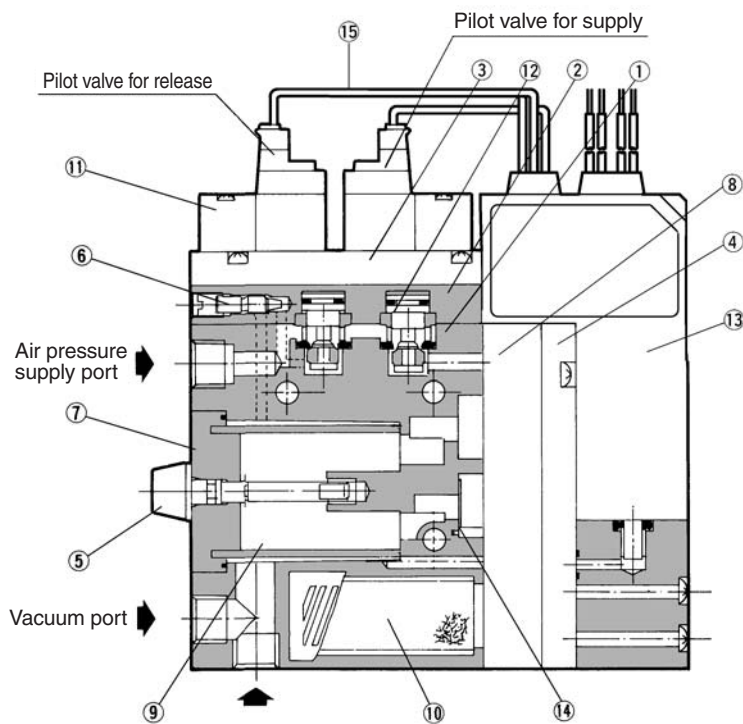

Component Parts

No.	Description	Material	Note
1	Body	Aluminum die-casted	
2	Valve cover	Resin	
3	Adapter plate	Resin	
4	Cover	Zinc die-casted	ZMA-HCB
5	Tension bolt	Stainless steel/Polyacetal	
6	Release flow rate adjusting needle	Brass	Electroless nickel plated

Replacement Parts

No.	Description	Material	Part no.
7	Filter cover assembly	—	ZMA-FCB-0
8	Diffuser assembly	—	ZMA□□0□-0
9	Suction filter	Polyethylene	ZM-SF
10	Silencer assembly	—	ZM-SA
11	Pilot valve	—	SY114-5LOZ
12	Poppet valve assembly	—	ZMA-PV
13	Vacuum switch with timer	—	ZMA-T14CN #1 (NPN) ZMA-T54CN #1 (PNP)
14	Check valve	NBR	ZM-CV
15	Connector assembly	—	ZMA-VC-1A #1

Exhaust Characteristics/Flow Characteristics, Standard Supply Pressure: H ... 0.5 MPa

ZMA05□H

Exhaust Characteristics

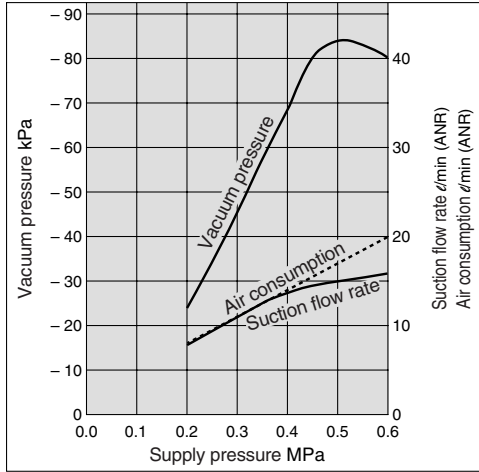

Flow Characteristics

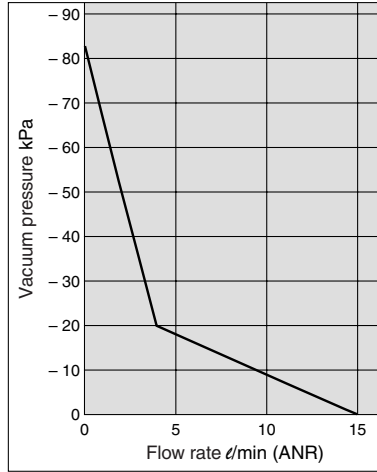

ZMA07□H

Exhaust Characteristics

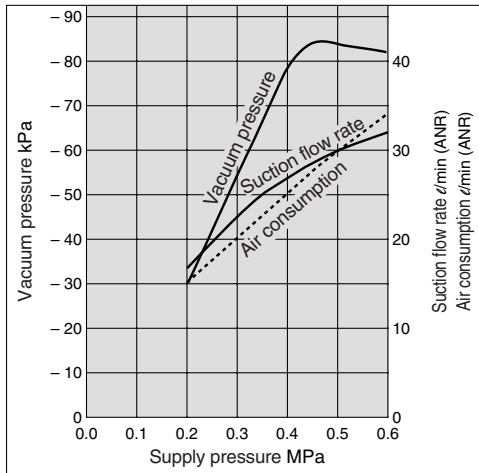

Flow Characteristics

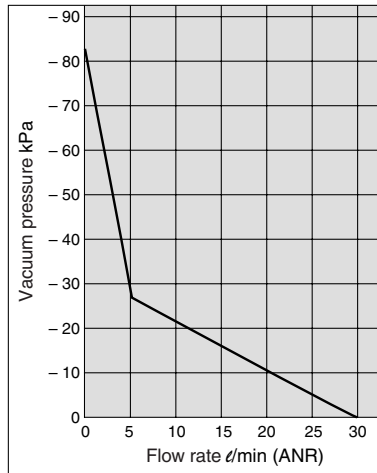

ZMA10□H

Exhaust Characteristics

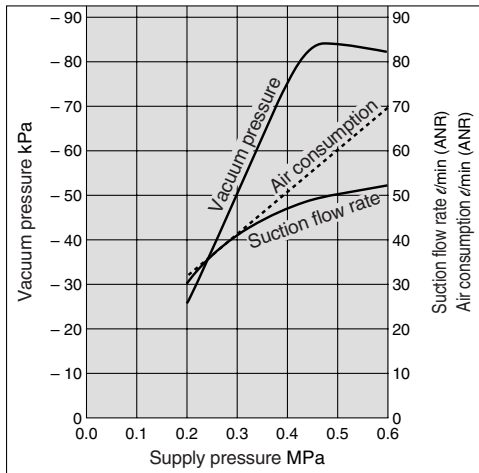

Flow Characteristics

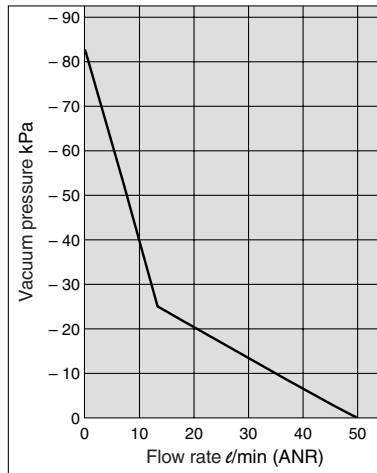

- ZA
- ZX
- ZR
- ZM
- ZMA**
- ZQ
- ZH
- ZU
- ZL
- ZY□
- ZF□
- ZP□
- SP
- ZCUK
- AMJ
- AMV
- AEP
- HEP
- Related Equipment

Series ZMA

Exhaust Characteristics/Flow Characteristics, Standard Supply Pressure: H ... 0.5 MPa

ZMA13□H

Exhaust Characteristics

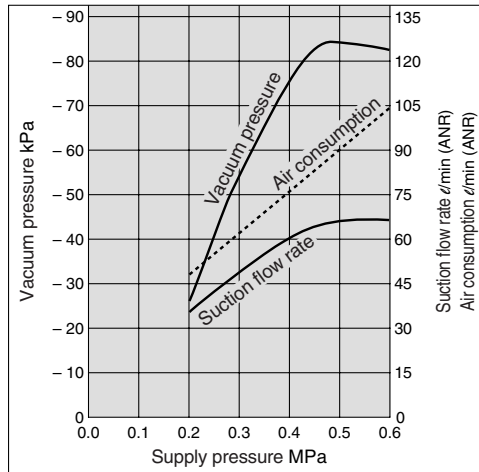

Flow Characteristics

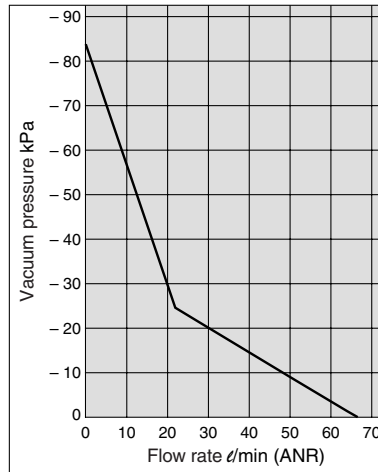

Exhaust Characteristics/Flow Characteristics, Standard Supply Pressure: S ... 0.45 MPa

ZMA13□S

Exhaust Characteristics

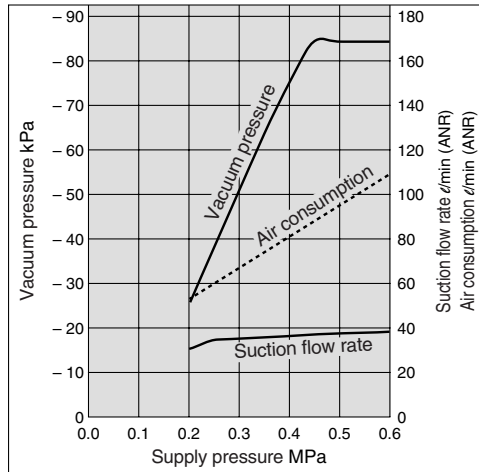

Flow Characteristics

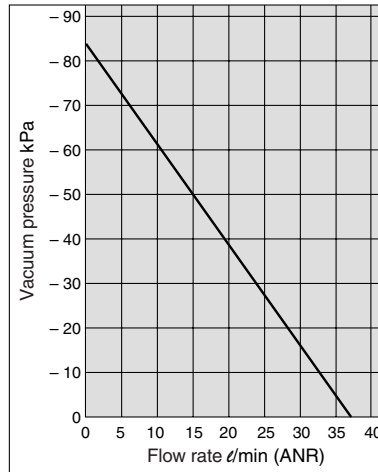

ZMA15□S

Exhaust Characteristics

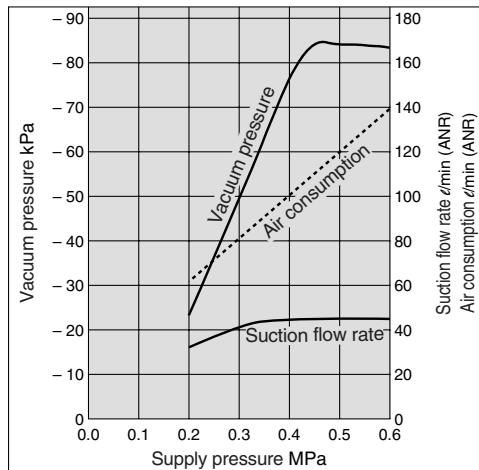

Flow Characteristics

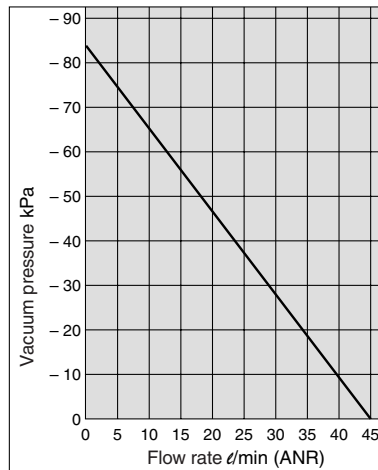

Exhaust Characteristics/Flow Characteristics, Standard Supply Pressure: M ... 0.35 MPa

ZMA07 □ M

Exhaust Characteristics

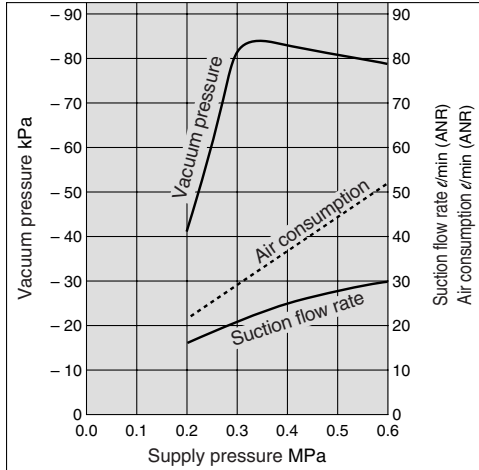

Flow Characteristics

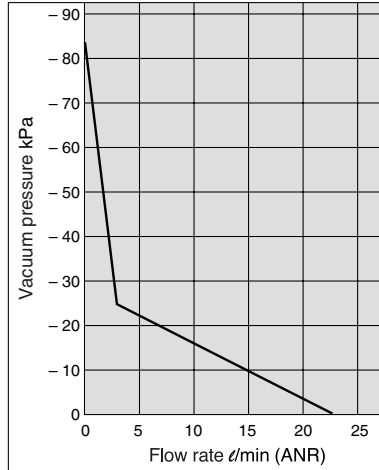

How to Read Flow Characteristics Graph

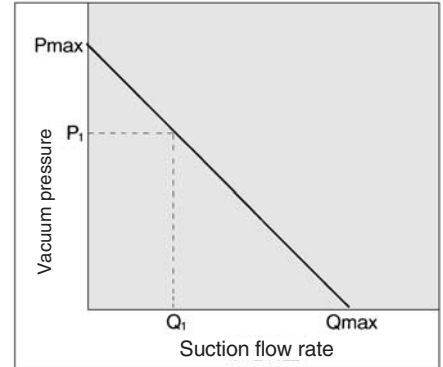

Flow characteristics are expressed in ejector vacuum pressure and suction flow. If suction flow rate changes, a change in vacuum pressure will also be expressed. Normally this relationship is expressed in ejector standard supply pressure. In graph, Pmax is max. vacuum pressure and Qmax is max. suction flow. The values are specified according to catalog use. Changes in vacuum pressure are expressed in the order below.

1. When ejector suction port is covered and made airtight, suction flow is 0 and vacuum pressure is at maximum value (Pmax).
 2. When suction port is opened gradually, air can flow through (air leakage), suction flow increases, but vacuum pressure decreases (condition P₁ and Q₁).
 3. When suction port is opened further, suction flow moves to maximum value (Qmax), but vacuum pressure is near 0 (atmospheric pressure).
- When vacuum port (vacuum piping) has no leakage, vacuum pressure becomes maximum, and vacuum pressure decreases as leakage increases. When leakage value is the same as max. suction flow, vacuum pressure is near 0. When ventilative or leaky work must be adsorbed, please note that vacuum pressure will not be high.

ZMA10 □ M

Exhaust Characteristics

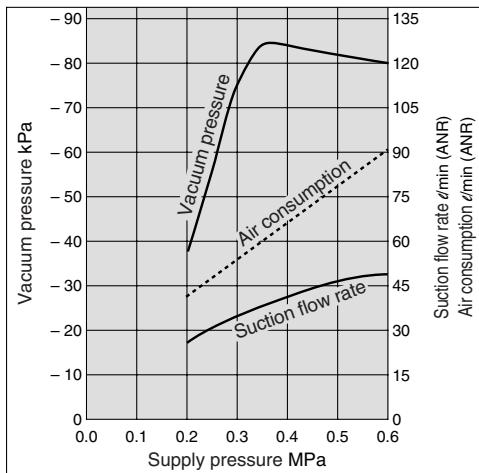

Flow Characteristics

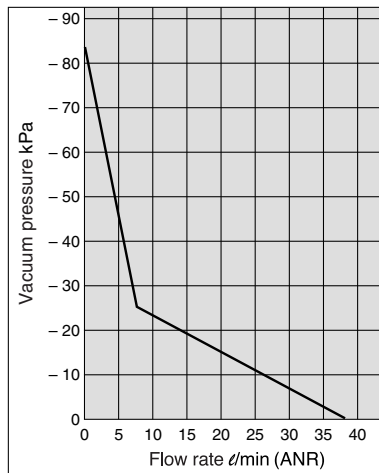

ZMA13 □ M

Exhaust Characteristics

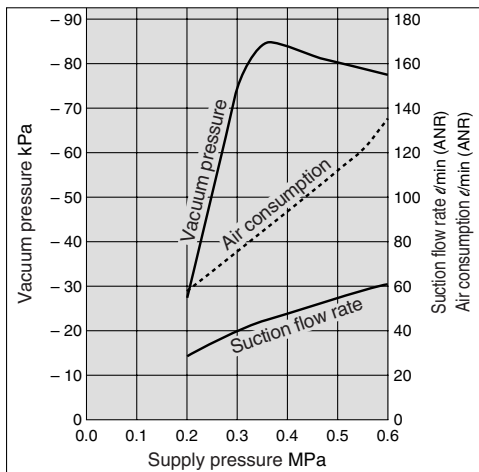

Flow Characteristics

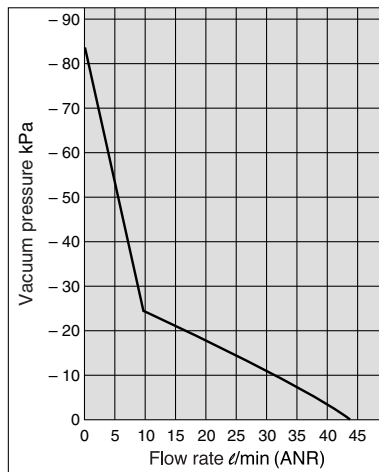

- ZA
- ZX
- ZR
- ZM
- ZMA**
- ZQ
- ZH
- ZU
- ZL
- ZY □
- ZF □
- ZP □
- SP
- ZCUK
- AMJ
- AMV
- AEP
- HEP
- Related Equipment

Series ZMA

Dimensions

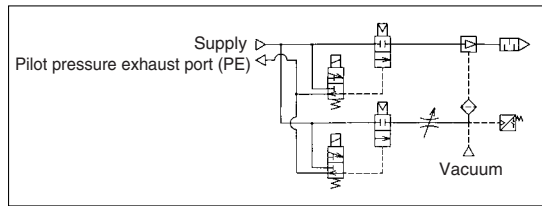

(ZMA_{13/15} 1S-K5-T14C)

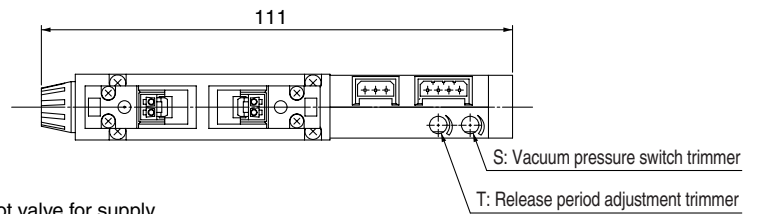

A: Release flow rate adjusting needle with lock nut

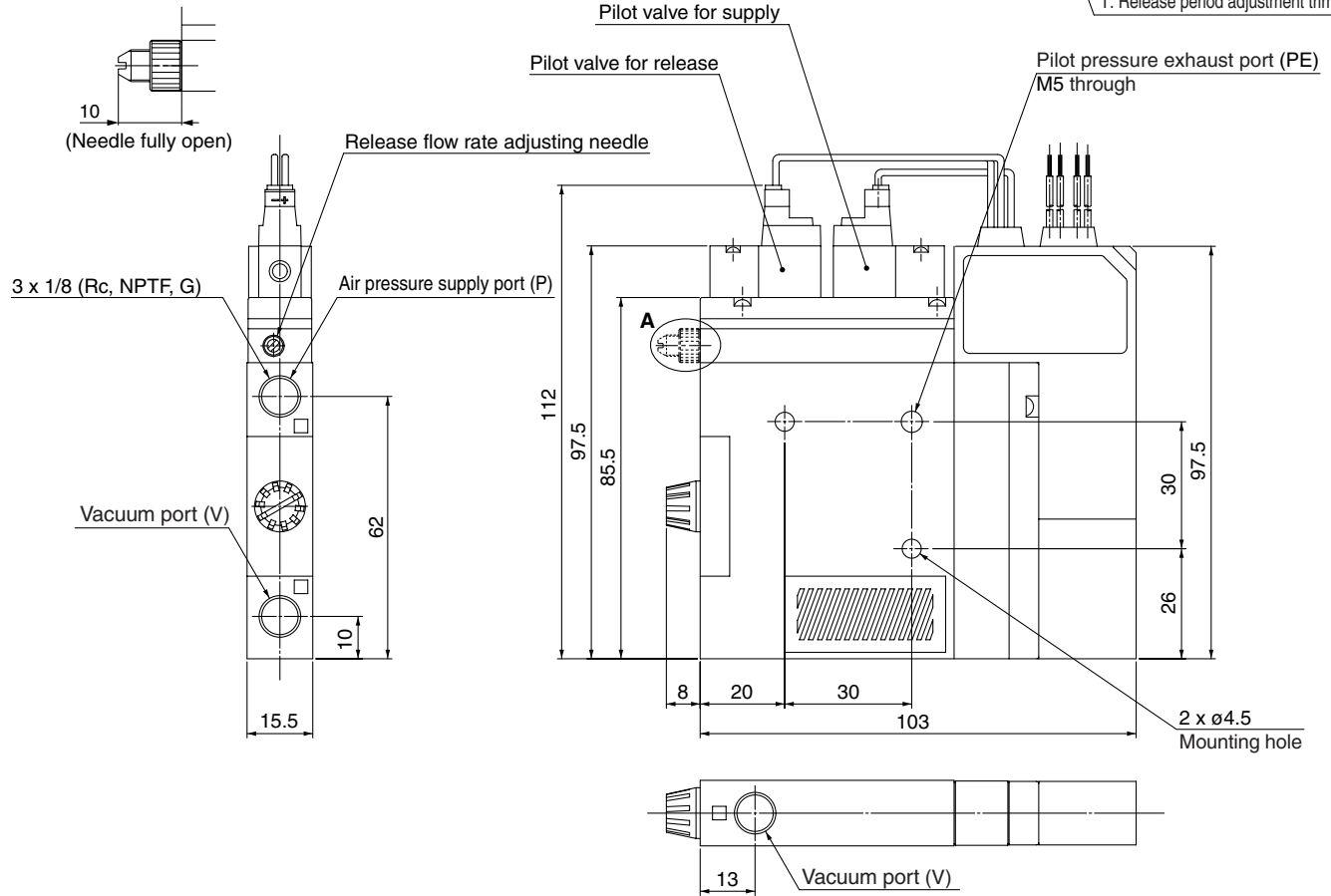

Manifold Specifications: Series ZZMA

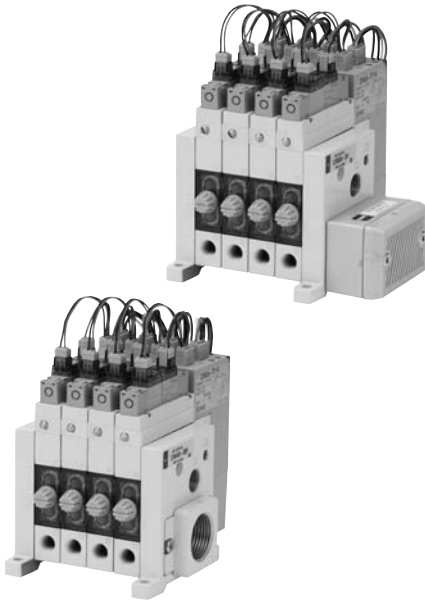

Manifold Specifications

Manifold style	Stacking
Common air pressure supply port (P) *	1/4 (Rc, NPTF, G)
Individual air pressure supply port (P) *	1/8 (Rc, NPTF, G)
Common exhaust port	1/2, 3/4 (Rc, NPTF, G)
Position of common exhaust port (EXH)	Right side/Left side/Both sides**
Max. number of stations	Max. 10 stations
Silencer	ZZM-SA (With bolts)

* The common air pressure supply port (P) and individual air pressure supply port (P) can be mounted together.
** Right and left sides are viewed from the front side of vacuum port (V).

Maximum Ejector Stations (Max. operable nos. simultaneously)

Manifold model	Ejector model				
	ZMA053 ZMA054	ZMA073 ZMA074	ZMA103 ZMA104	ZMA133 ZMA134	ZMA153 ZMA154
ZZMA [Stations]—06 ^R	10	8	5	4	3
ZZMA [Stations]—06 ^B	10	10	8	6	5
ZZMA [Stations]—04 ^R	10	8	5	4	3
ZZMA [Stations]—04 ^B	10	10	8	6	5

* Effective area of external silencer is 160 mm².
Cv value: 8.8

How to Order Ejector Manifold

ZZMA 06 - [] 06 R - R

Number of stations

01	1 station
:	:
10	10 stations (max.)

(By viewing the front side of vacuum port (V), stations are counted starting from station 1 on the left side.)

Thread type

Nil	Rc
T	NPTF
F	G*

* G thread
The thread ridge shape is compatible with the G thread standard (JIS B 0203), but other shapes are not conforming to ISO16030 and ISO1179.

Common air pressure supply port (P) location **

Nil	Both Sides
R	Right Side
L	Left Side

** Right and left side are viewed from the front side of vacuum port (V).

Common exhaust port (EXH) and silencer location

R	Right Side
L	Left Side
B	Both Sides

Note) Right and left side are viewed from the front side of vacuum port (V).

Common exhaust port (EXH) Size

04	1/2
06	3/4
S	Silencer dedicated for ZZMA (ZZM-SA)
00	Without exhaust port (Compatible with -X111)

The asterisk (*) indicates the ejector model no. below the manifold base no. Prefix it to the vacuum unit part numbers to be mounted. When it is not added, products are shipped separately.

Example) Manifold model no.: ZZMA04-SR (1 pc.)
Ejector model no. : * ZMA073H-K5-T14C (4 pcs.)

ZA

ZX

ZR

ZM

ZMA

ZQ

ZH

ZU

ZL

ZY□

ZF□

ZP□

SP

ZCUK

AMJ

AMV

AEP

HEP

Related Equipment

Series ZMA

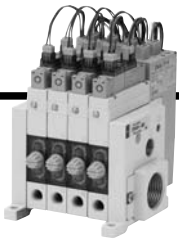

Manifold

ZMA Number of ejectors — Common EXH port — Port position

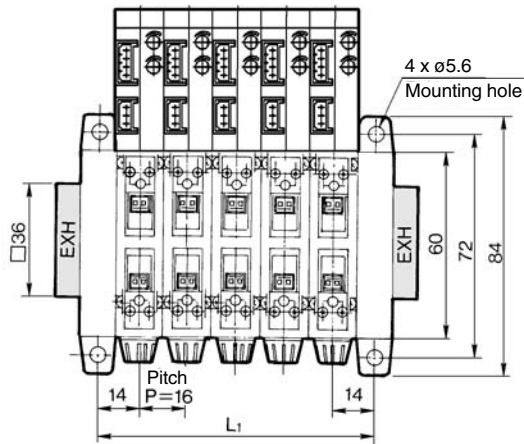

A: Release flow rate adjusting needle with lock nut

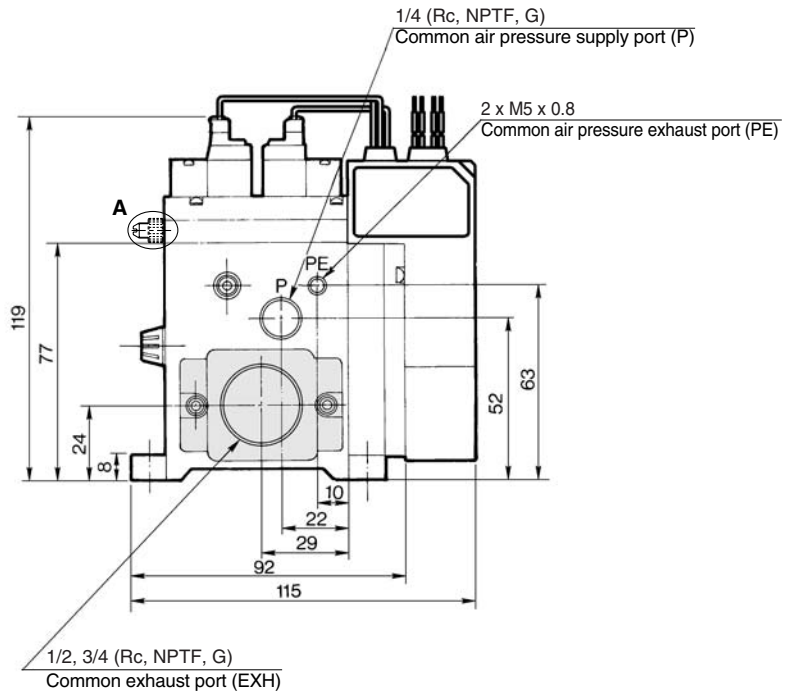
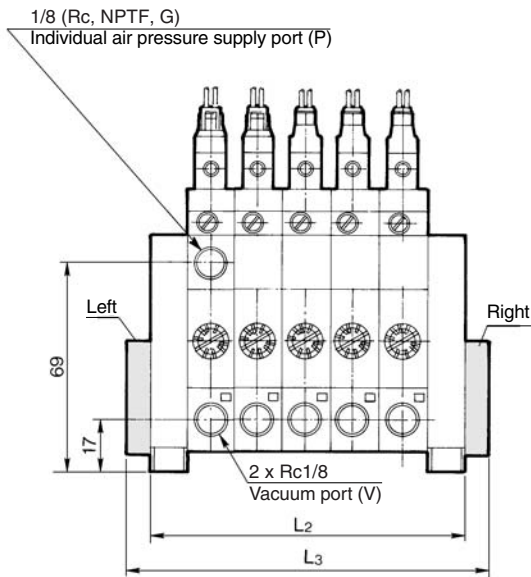
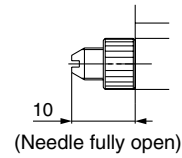

L	Stations	(mm)									
		1	2	3	4	5	6	7	8	9	10
	L1	28 ±1.5	44 ±1.5	60 ±1.5	76 ±1.5	92 ±1.5	108 ±2.0	124 ±2.0	140 ±2.0	156 ±2.0	172 ±2.0
	L2	40 ±1.5	56 ±1.5	72 ±1.5	88 ±1.5	104 ±1.5	120 ±2.0	136 ±2.0	152 ±2.0	168 ±2.0	184 ±2.0
	L3	56 ±1.5	72 ±1.5	88 ±1.5	104 ±1.5	120 ±1.5	136 ±2.0	152 ±2.0	168 ±2.0	184 ±2.0	200 ±2.0

Vacuum Ejector With Solid State Timer **Series ZMA**

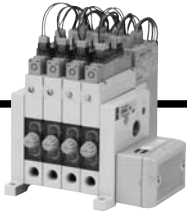

<Components>
Manifold/With Silencer **Manifold with Silencer Dedicated for Manifold**

ZZMA Number of ejectors — **S** Position of silencer

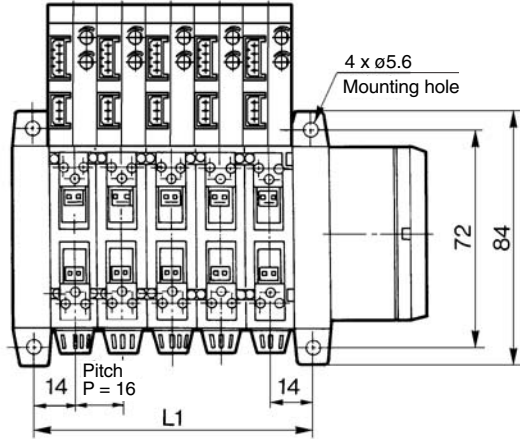

A: Release flow rate adjusting needle with lock nut

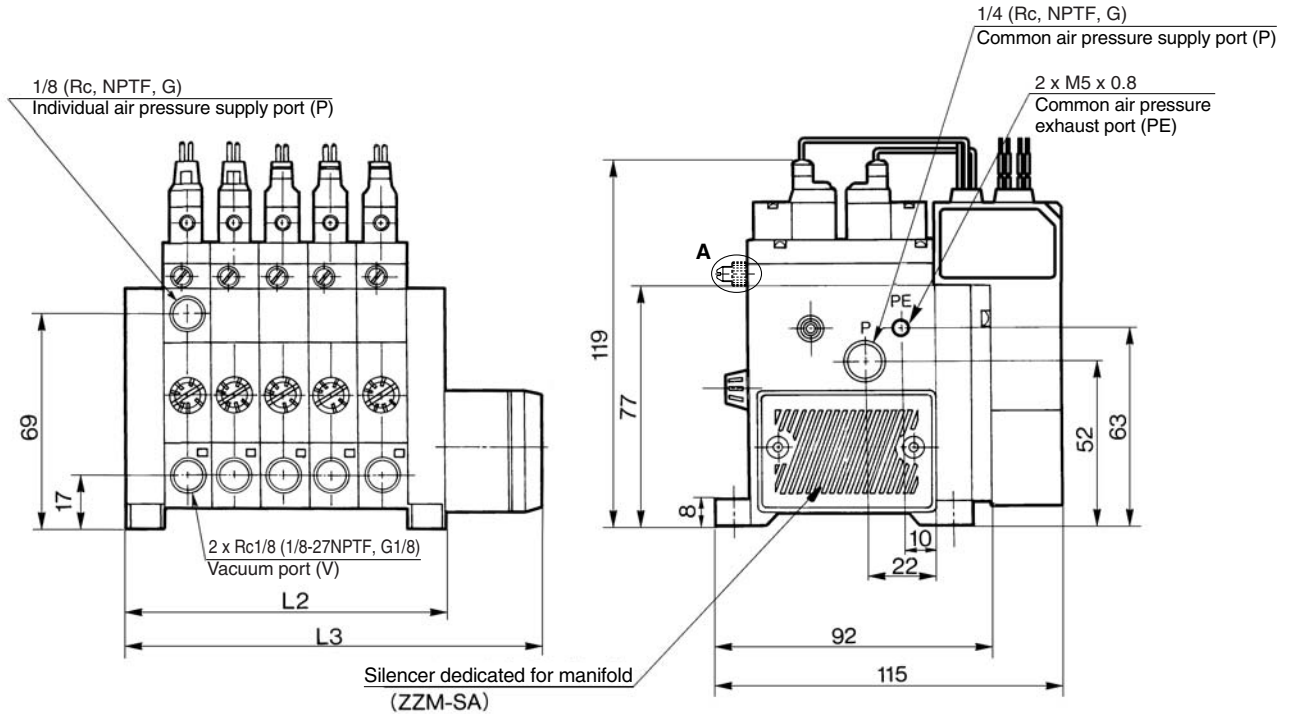
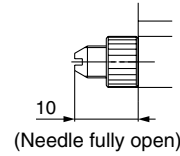

- ZA
- ZX
- ZR
- ZM
- ZMA**
- ZQ
- ZH
- ZU
- ZL
- ZY□
- ZF□
- ZP□
- SP
- ZCUK
- AMJ
- AMV
- AEP
- HEP
- Related Equipment

	Stations	1	2	3	4	5	6	7	8	9	10
L1		28 ±1.5	44 ±1.5	60 ±1.5	76 ±1.5	92 ±1.5	108 ±2.0	124 ±2.0	140 ±2.0	156 ±2.0	172 ±2.0
L2		40 ±1.5	56 ±1.5	72 ±1.5	88 ±1.5	104 ±1.5	120 ±2.0	136 ±2.0	152 ±2.0	168 ±2.0	184 ±2.0
L3		72 ±1.5	88 ±1.5	104 ±1.5	120 ±1.5	136 ±1.5	152 ±2.0	168 ±2.0	184 ±2.0	200 ±2.0	216 ±2.0