

Compact Slide Series *MXU*

How to Order

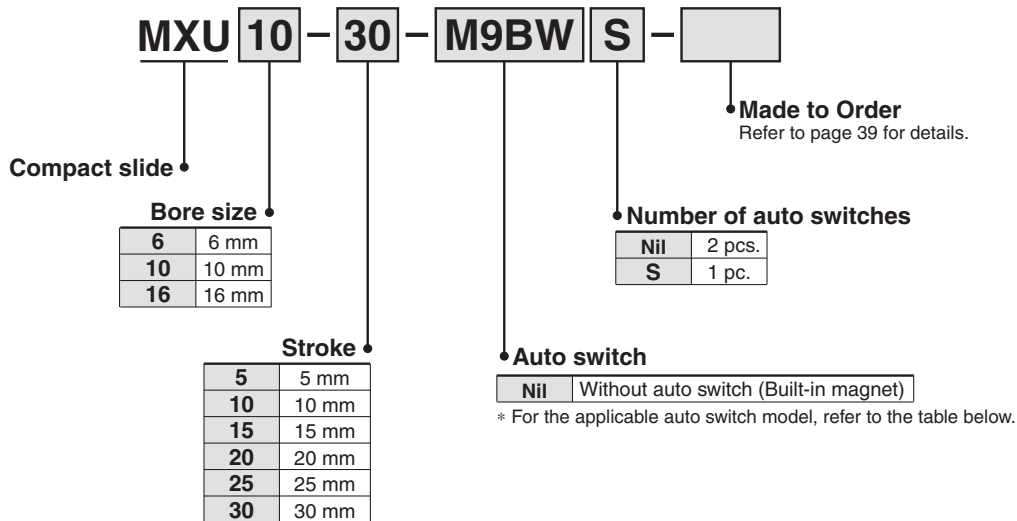

Applicable Auto Switch/Refer to pages 1719 to 1827 for further information on auto switches.

Type	Special function	Electrical entry	Indicator light	Wiring (Output)	Load voltage		Auto switch model		Lead wired length (m)				Pre-wired connector	Applicable load			
					DC	AC	Perpendicular	In-line	0.5 (Nil)	1 (M)	3 (L)	5 (Z)					
Solid state switch	Diagnostic indication (2-color indication)	Grommet	Yes	3-wire (NPN)	24 V	5 V, 12 V	—	M9NV	M9N	●	●	●	○	○	IC circuit	Relay, PLC	
				3-wire (PNP)				M9PV	M9P	●	●	●	○	○			
				2-wire				M9BV	M9B	●	●	●	○	○	—		
				3-wire (NPN)				M9NWV	M9NW	●	●	●	○	○	IC circuit		
				3-wire (PNP)				M9PWV	M9PW	●	●	●	○	○	IC circuit		
				2-wire				M9BWV	M9BW	●	●	●	○	○	—		
Reed switch	—	Grommet	No	3-wire (NPN equivalent)	24 V	5 V	—	A96V	A96	●	—	●	—	—	IC circuit	—	
				2-wire				100 V	A93V	A93	●	—	●	—	—	—	Relay, PLC
								100 V or less	A90V	A90	●	—	●	—	—	—	IC circuit

* Lead wire length symbols: 0.5 m Nil (Example) M9NW
 1 m M (Example) M9NWM
 3 m L (Example) M9NWL
 5 m Z (Example) M9NWZ

* Solid state auto switches marked with "○" are produced upon receipt of order.

- * Since there are other applicable auto switches than listed, refer to page 47 for details.
- * For details about auto switches with pre-wired connector, refer to pages 1784 and 1785.
- * Auto switches are shipped together (not assembled).

Specifications



Made to Order Specifications
(For details, refer to page 1865.)

Symbol	Specifications
-XB13	Low speed cylinder (5 to 50 mm/s)

Bore size (mm)	6	10	16
Fluid	Air		
Action	Double acting		
Piping port size	M5 x 0.8		
Maximum operating pressure	0.7 MPa		
Proof pressure	1.05 MPa		
Ambient & fluid temperature	Without auto switch: -10 to +70°C With auto switch: -10 to +60°C		
Piston speed	50 to 500 mm/sec		
Lubrication	Non-lube		
Cushion	Rubber bumper on both ends		
Stroke length tolerance	+1.0 0		
Auto switch (Option)	Reed auto switch Solid state auto switch (2-wire, 3-wire)		

MXH

MXU

MXS

MXQ

MXF

MXW

MXJ

MXP

MXY

MTS

Minimum Operating Pressure

Bore size (mm)	6	10	16
Min. operating pressure (MPa)	0.12	0.06	0.06

Theoretical Output

Bore size (mm)	Rod size (mm)	Operating direction	Piston area (mm ²)	Operating pressure (MPa)		
				0.3	0.5	0.7
6	3	OUT	28.3	8.49	14.2	19.8
		IN	21.2	6.36	10.6	14.8
10	4	OUT	78.5	23.6	39.3	55.0
		IN	66.0	19.8	33.0	46.2
16	6	OUT	201	60.3	101	141
		IN	172	51.6	86.0	121

Standard Stroke

Bore size (mm)	Standard stroke (mm)
6, 10, 16	5, 10, 15, 20, 25, 30

* Refer to "Minimum Stroke for Auto Switch Mounting" on page 46.

Mass

Model	Cylinder stroke (mm)					
	5	10	15	20	25	30
MXU6	66	72	81	88	97	103
MXU10	115	124	138	147	166	174
MXU16	216	215	251	250	285	300

D-□

-X□

Individual
-X□

Allowable Moment

Model	Stroke	Allowable moment (N·m)			Correction value of moment center position distance (mm)	
		M1	M2	M3	Cp, Cy	Cr
MXU6	5	0.046	0.040	0.049	28.3	7.5
	10	0.046	0.040	0.049	28.3	
	15	0.061	0.053	0.062	31.5	
	20	0.061	0.053	0.062	34	
	25	0.076	0.066	0.074	38.5	
	30	0.076	0.066	0.074	41	
MXU10	5	0.047	0.041	0.109	28.5	9.5
	10	0.047	0.041	0.109	31	
	15	0.080	0.069	0.169	36	
	20	0.080	0.069	0.169	38.5	
	25	0.103	0.089	0.212	44	
	30	0.103	0.089	0.212	46	
MXU16	5	0.115	0.099	0.296	37.5	12
	10	0.115	0.099	0.296	37.5	
	15	0.153	0.132	0.380	46	
	20	0.153	0.132	0.380	46	
	25	0.190	0.165	0.464	50	
	30	0.190	0.165	0.464	52.5	

⚠ Precautions

Be sure to read before handling. Refer to front matters 42 and 43 and pages 3 to 11 for Actuator and Auto Switch Precautions.

⚠ Caution

- Do not place your fingers in the clearance between the table and the cylinder tube. Your fingers could get caught between the table and the cylinder tube when the piston rod retracts. Because the cylinder outputs a great force, it could lead to injury if precautions are not taken to prevent your fingers from getting caught.
- In terms of the load weight and moment, the cylinder must be operated below the maximum load weight and allowable moment.
- If the output of the compact slide is applied directly to the table, make sure it is applied along the rod axial line. (Refer to the figure below.)

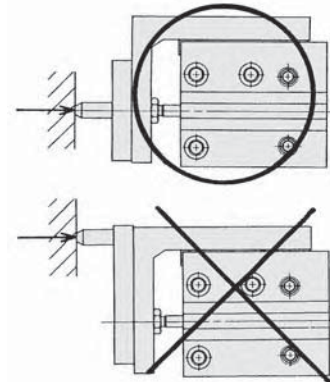

- Make sure to connect a speed controller and adjust it to a speed of 500 mm/s or less to operate the cylinder.

Expression of Calculation of Allowable Fp, Fy, Fr

Pitch moment	Yaw moment	Roll moment
$F_p = \frac{M_1 \times 1000}{L_p + C_p + (St/2)} \text{ (N)}$ <p>Lp: Distance between table and loading point (mm) Cp: Correction value of moment center position distance (mm) St: Stroke (mm)</p>	$F_y = \frac{M_2 \times 1000}{L_y + C_y + (St/2)} \text{ (N)}$ <p>Ly: Distance between table and loading point (mm) Cy: Correction value of moment center position distance (mm) St: Stroke (mm)</p>	$F_r = \frac{M_3 \times 1000}{L_r + C_r} \text{ (N)}$ <p>Lr: Distance between table and loading point (mm) Cr: Correction value of moment center position distance (mm)</p>

Mounting of Compact Slide

The compact slide can be mounted in four directions. Select the best direction according to the machine and work to be used.

Lateral Mounting (Body through-hole)

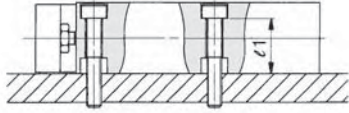

Model	Bolt	Maximum tightening torque (N-m)	ℓ1
MXU6	M3 x 0.5	1.1	12.7
MXU10	M4 x 0.7	2.5	15.6
MXU16	M4 x 0.7	2.5	20.6

Lateral Mounting (Body tapped)

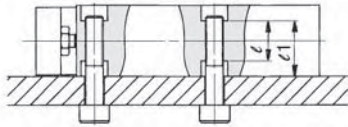

Model	Bolt	Maximum tightening torque (N-m)	ℓ1	ℓ
MXU6	M4 x 0.7	2.5	12.7	9.4
MXU10	M5 x 0.8	5.1	15.6	11.2
MXU16	M5 x 0.8	5.1	20.6	16.2

Vertical Mounting (Body tapped)

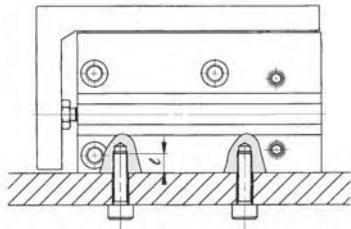

Model	Bolt	Maximum tightening torque (N-m)	ℓ
MXU6	M3 x 0.5	1.1	4.8
MXU10	M4 x 0.7	2.5	6
MXU16	M4 x 0.7	2.5	6

Axial Mounting (Body tapped)

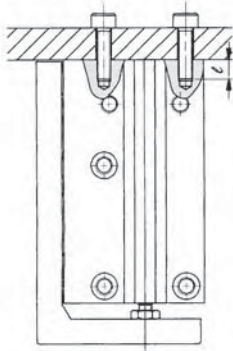

Model	Bolt	Maximum tightening torque (N-m)	ℓ
MXU6	M3 x 0.5	1.1	4.8
MXU10	M4 x 0.7	2.5	6
MXU16	M4 x 0.7	2.5	6

Mounting of Workpiece

Workpieces can be mounted on 2 surfaces of the compact slide.

- The table is supported by miniature linear guide. Be careful not to apply strong impacts or excessive moments when mounting work.
- Hold the table when fastening workpieces to it with bolts, etc. If the body is held while tightening bolts, etc., the guide section will be subjected to a large moment, and there may be a loss of precision.

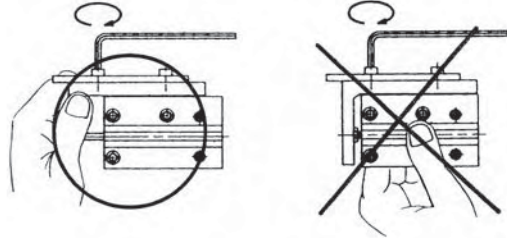

- When tightening the work on the table with bolts, it should be done while holding the table. If holding the body, it may cause more than allowable moment to the guide, leading to decrease in accuracy.
- For connection with a load having an external support/guide mechanism, select an appropriate connection method and perform careful alignment.
- Use caution, as scratches or nicks, etc. on the sliding parts of the piston rod can cause malfunction and air leakage.

Front Mounting

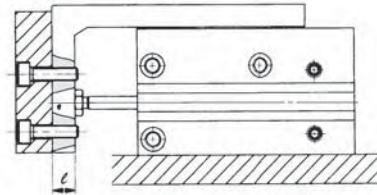

Model	Bolt	Maximum tightening torque (N-m)	ℓ
MXU6	M3 x 0.5	1.1	5
MXU10	M4 x 0.7	2.5	7
MXU16	M4 x 0.7	2.5	9.5

Top Mounting

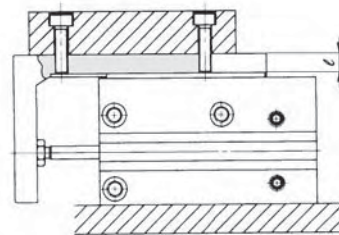

Model	Bolt	Maximum tightening torque (N-m)	ℓ
MXU6	M3 x 0.5	1.1	5
MXU10	M4 x 0.7	2.5	6
MXU16	M4 x 0.7	2.5	6

Operating Direction with Different Pressure Ports

- Order the plug below when changing the port position.
Plug part no. (for replacement):
CXS10-08-28747A

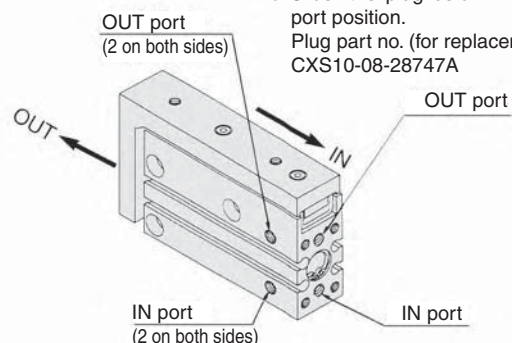

MXH

MXU

MXS

MXQ

MXF

MXW

MXJ

MXP

MXY

MTS

D-□

-X□

Individual
-X□

Series MXU

Construction

MXU6 (ø6)

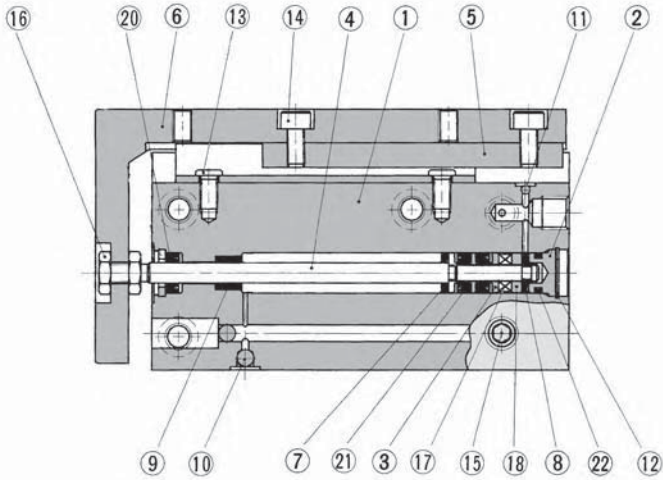

MXU10 (ø10)

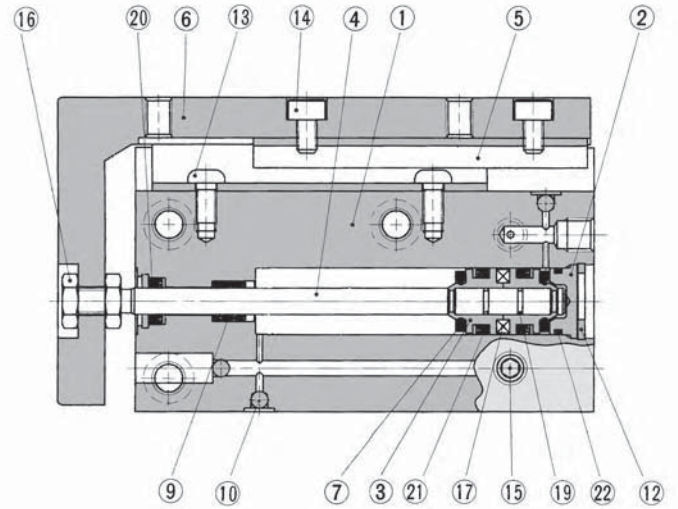

MXU16 (ø16)

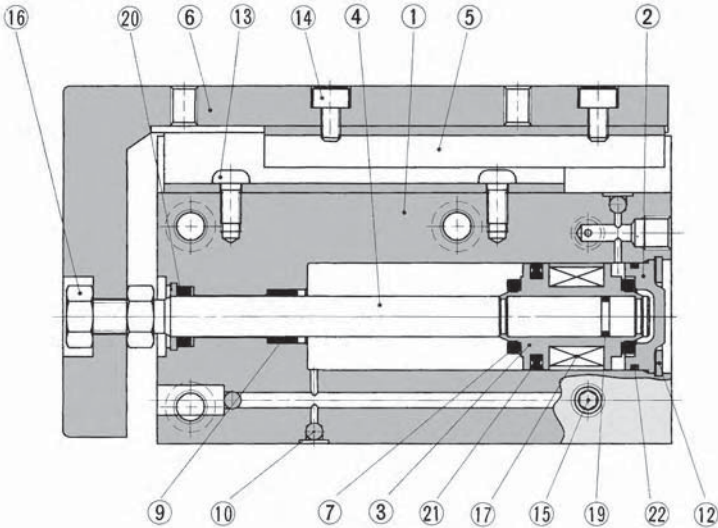

Component Parts

No.	Description	Material	Note
1	Cylinder tube	Aluminum alloy	Hard anodized
2	Head cover	Brass	ø6, ø10 Electroless nickel plated
		Aluminum alloy	ø16 chromated
3	Piston	Brass	ø6, ø10
		Aluminum alloy	ø16
4	Piston rod	Stainless steel	
5	Miniature linear guide	—	
6	Table	Aluminum alloy	Hard anodized
7	Bumper A	Urethane	
8	Bumper B	Urethane	
9	Bushing	Oil-impregnated sintered alloy	Oil impregnated
10	Steel ball A	High carbon chrome bearing steel	
11	Steel ball B	High carbon chrome bearing steel	
12	Type C retaining ring for hole	Carbon tool steel	Phosphate coated
13	Round head Phillips screw	Carbon steel	

Component Parts

No.	Description	Material	Note
14	Hexagon socket head cap screw	Chromium molybdenum steel	Nickel plated
15	Hexagon socket head plug	Chromium molybdenum steel	Nickel plated
16	Rod end nut	Carbon steel	Nickel plated
17	Magnet	—	ø6, ø10
		—	ø16
18	Magnet holder	Brass	
19	Piston gasket	NBR	
20	Rod seal	NBR	
21	Piston seal	NBR	
22	Gasket	NBR	

* Series MXU cannot be disassembled.

Dimensions: MXU6 (ø6)

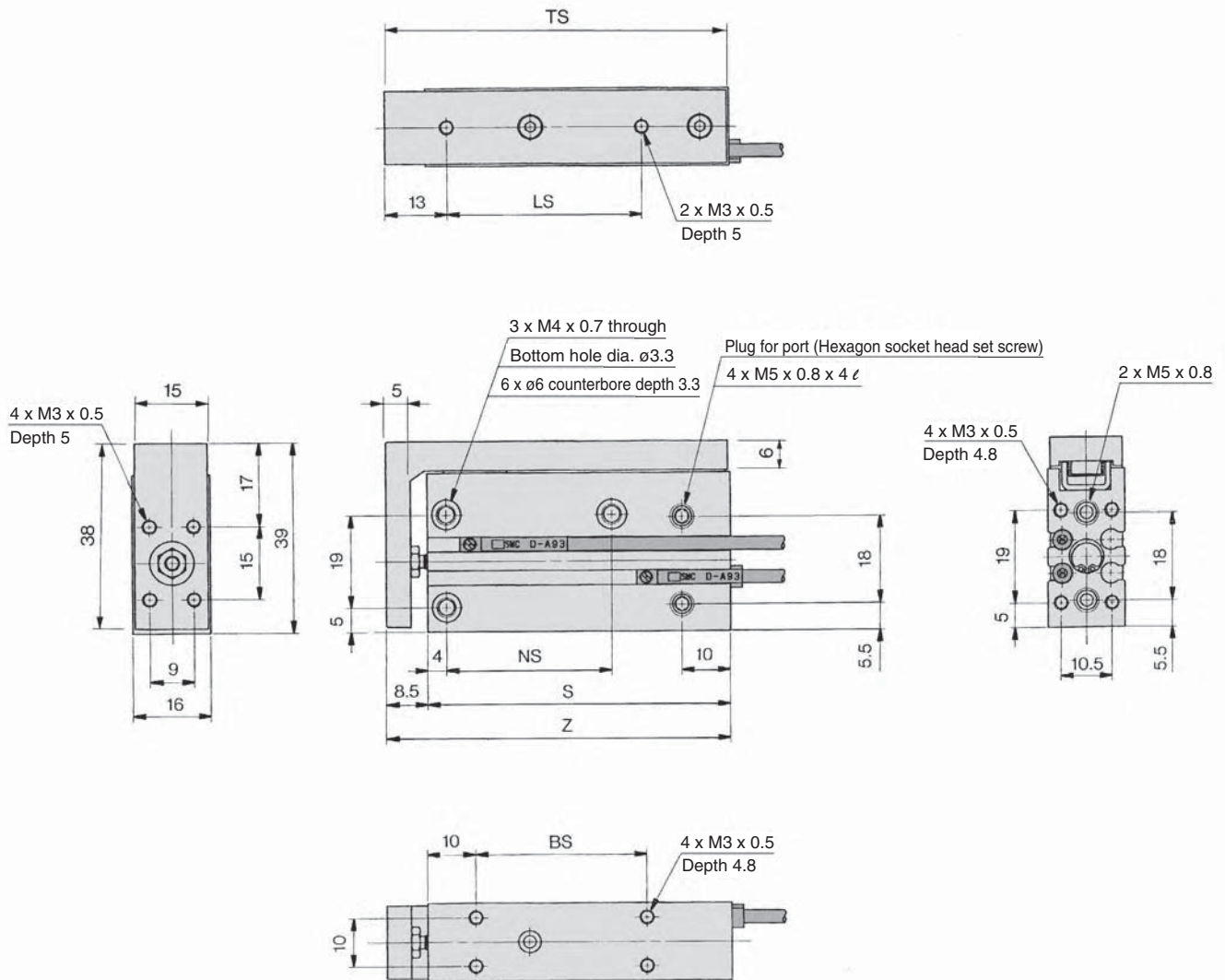

- MXH**
- MXU**
- MXS**
- MXQ**
- MXF**
- MXW**
- MXJ**
- MXP**
- MXY**
- MTS**

Stroke (mm)	BS	LS	NS	S	Z	TS
5	10	20	14	37.5	46	45.5
10	15	20	14	42.5	51	50.5
15	20	25	24	47.5	56	55.5
20	25	30	24	52.5	61	60.5
25	30	40	34	57.5	66	65.5
30	35	40	34	62.5	71	70.5

- D-□**
- X□**
- Individual
-X□

Series MXU

Dimensions: MXU10 (ø10)

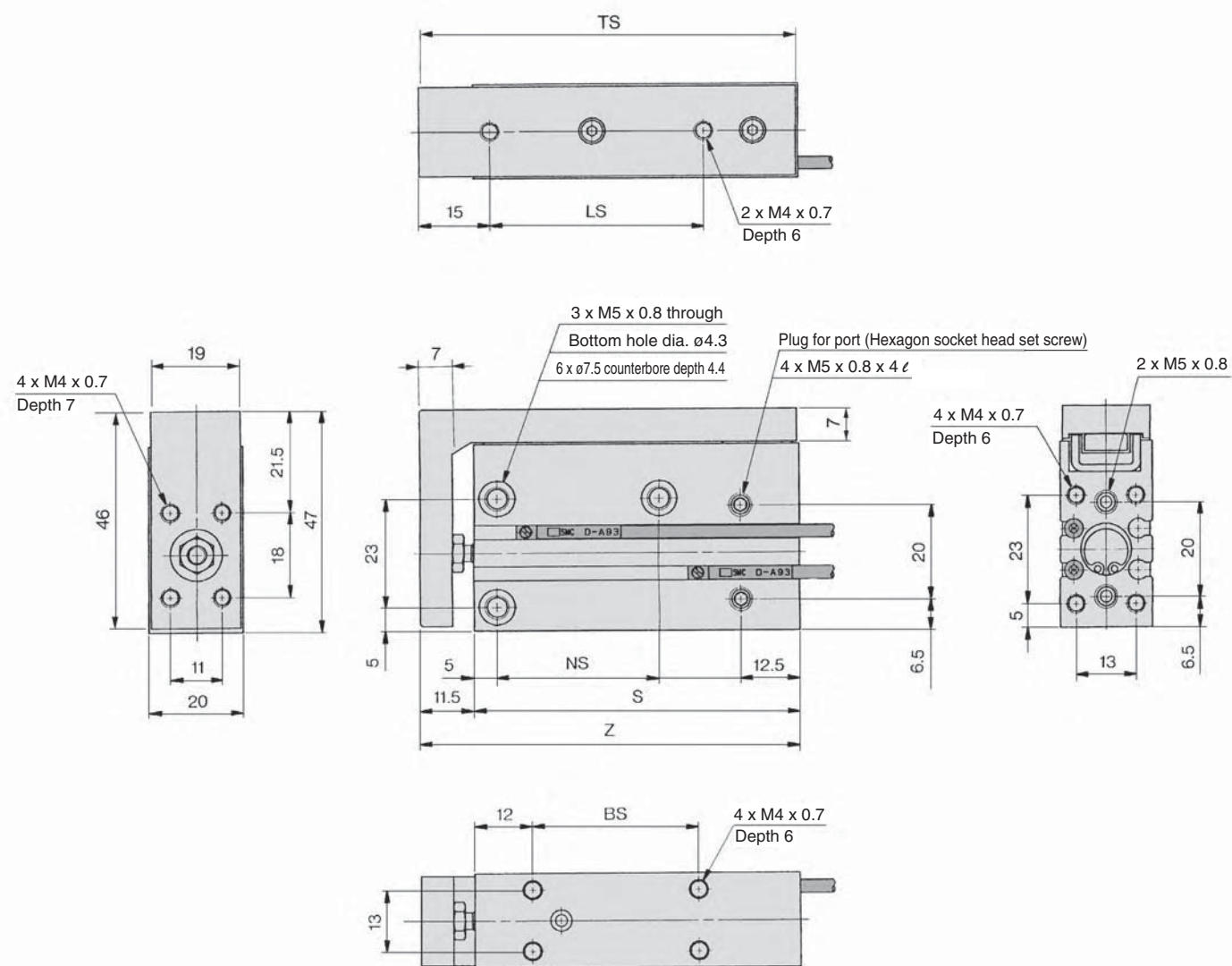

Stroke (mm)	BS	LS	NS	S	Z	TS
5	10	14	14	41.5	53	52.5
10	14	19	14	46.5	58	57.5
15	18	25	24	51.5	63	62.5
20	24	30	24	56.5	68	67.5
25	32	40	34	64.5	76	75.5
30	35	45	34	68.5	80	79.5

Dimensions: MXU16 (ø16)

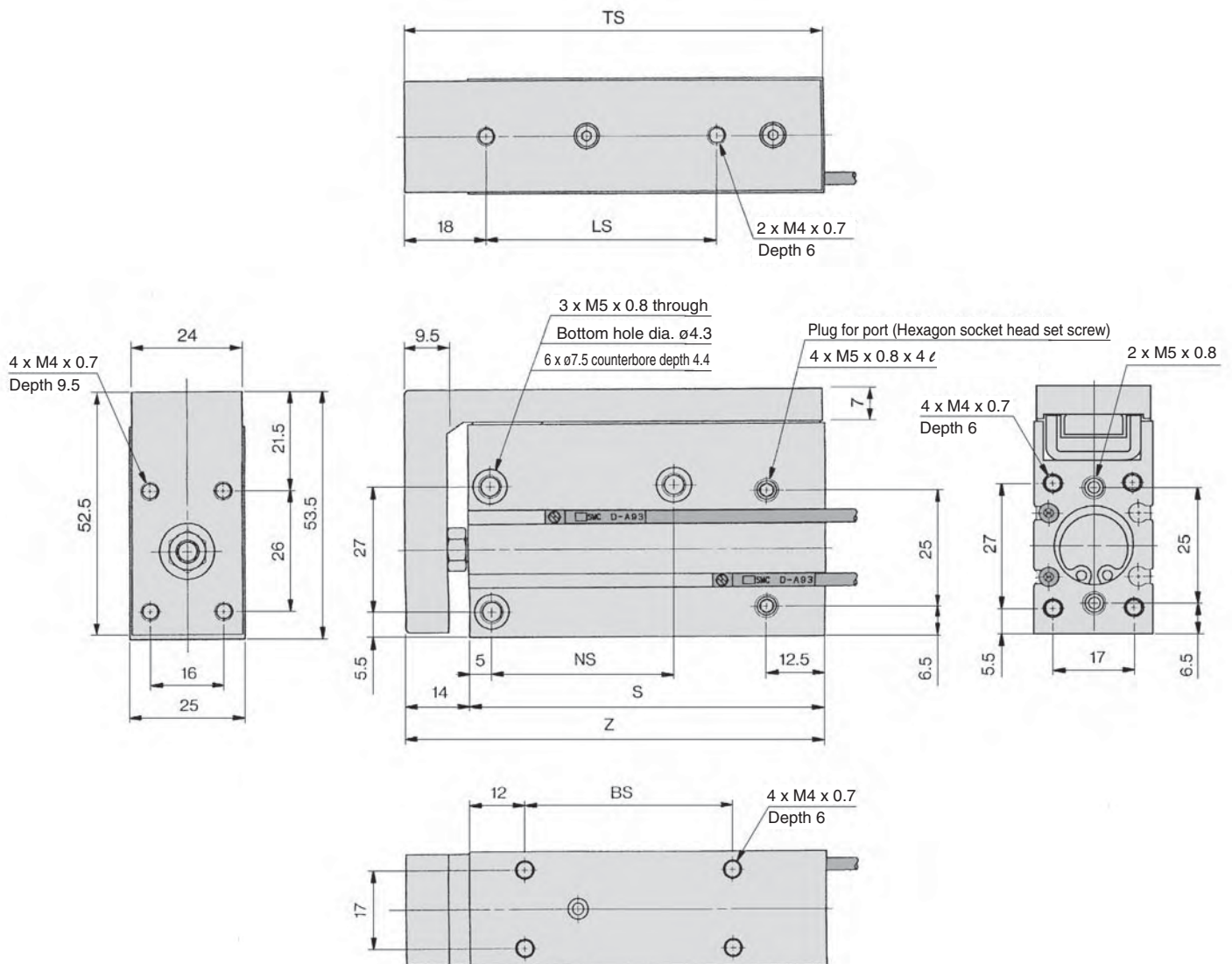

- MXH
- MXU
- MXS
- MXQ
- MXF
- MXW
- MXJ
- MXP
- MXY
- MTS

Stroke (mm)	BS	LS	NS	S	Z	TS
5	20	24	24	52	66	65.5
10	20	24	24	52	66	65.5
15	30	35	34	62	76	75.5
20	30	35	34	62	76	75.5
25	40	45	40	72	86	85.5
30	45	50	40	77	91	90.5

- D-□
- X□
- Individual
- X□

Series MXU

Auto Switch Proper Mounting Position (Detection at Stroke End) and Its Mounting Height

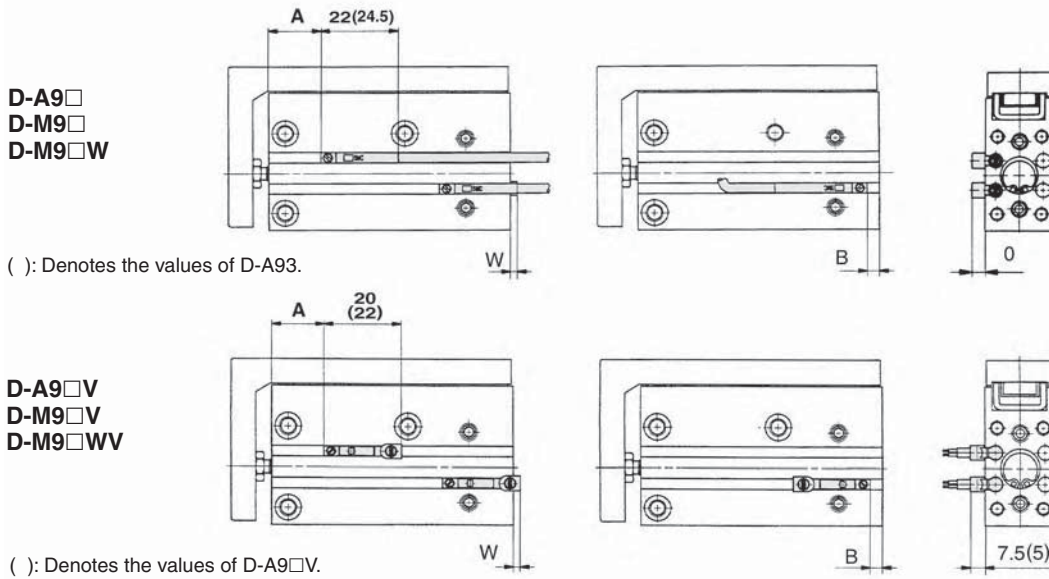

Auto Switch Groove Position

Bore size	Application stroke	(mm)								
		D-A9□, D-A9□V			D-M9□, D-M9□W			D-M9□V, D-M9□WV		
		A	B	W	A	B	W	A	B	W
6	5 to 30	13	0	2.5(5)	17	3.5	6.5	17	3.5	4.5
10	5 to 20	13	3.5	-1.5 (1)	17	7.5	2.5	17	7.5	0.5
	25	20			20					
	30	19			19					
16	5	23	4	-2 (0.5)	27	8	2	27	8	0
	10	18			22			22		
	15	23			27			27		
	20	18			22			22		
	25	23			27			27		
	30	23			27			27		

- Note 1) Negative figures in the table W indicate an auto switch is mounted inward from the edge of the cylinder body.
- Note 2) In the case of models with 5 and 10 strokes, the switch may not turn off within the operation range or two switches may turn on simultaneously. Fix switches outside 1 to 4 mm further than the values in the above table (if 1 switch is used, make sure that it turns ON and OFF properly; if 2 switches are used, make sure that both switches turn ON).
- Note 3) () in column W is the dimensions of D-A93.

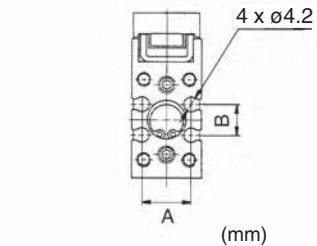

Bore size	A	B
6	10	6.9
10	14	8.8
16	19	13.9

Minimum Stroke for Auto Switch Mounting (mm)

No. of auto switches mounted	Applicable auto switch model		
	D-A9□ D-A9□V	D-M9□ D-M9□V	D-M9□W D-M9□WV
1 pc.	5	5	5
2 pcs.	10	5	10

Operating Range

Auto switch model	Bore size (mm)		
	6	10	16
D-A9□/A9□V	5	6	9
D-M9□/M9□V D-M9□W/M9□WV	3	3.5	4.5

* Since this is a guideline including hysteresis, not meant to be guaranteed. (assuming approximately ±30% dispersion.) There may be the case it will vary substantially depending on an ambient environment.

Auto Switch Mounting

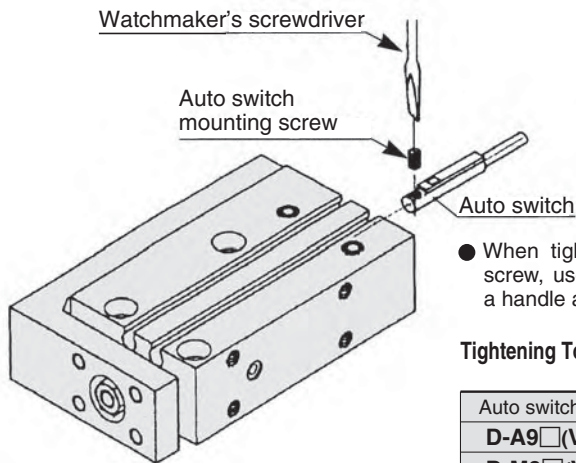

- When tightening the auto switch mounting screw, use a watchmaker's screwdriver with a handle about 5 to 6 mm in diameter.

Tightening Torque of Auto Switch Mounting Screw (N•m)

Auto switch mounting	Tightening torque
D-A9□(V)	0.10 to 0.20
D-M9□(V) D-M9□W(V)	0.05 to 0.15

Note) When used with side piping, it is not possible to mount a D-A9□V, M9□V auto switch type on the side to which the piping is connected.

MXH
MXU
MXS
MXQ
MXF
MXW
MXJ
MXP
MXY
MTS

Caution on Installing in Close Proximity to Each Other

When compact slide cylinders equipped with D-A9□ or D-M9□ auto switches are used, the auto switches could activate unintentionally if the installed distance is less than the dimension shown in Table (1). Therefore, make sure to provide at least this much clearance. Due to unavoidable circumstances, if they must be used with less distance than the dimensions given in the table below, the cylinders must be shielded. Therefore, affix a steel plate or a magnetic shield plate (MU-S025) to the area on the cylinder that corresponds to the adjacent auto switch. (Please contact SMC for details.) The auto switch could activate unintentionally if a shield plate is not used.

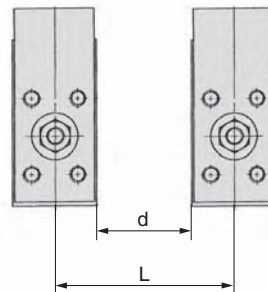
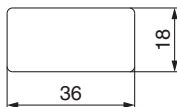

Table (1) (mm)

Bore size (mm)	d	L
MXU6	5	21
MXU10	5	25
MXU16	10	35

Dimensions of shield plate (MU-S025) that is sold separately are indicated as reference.



Material: Ferrite stainless steel, Thickness: 0.3 mm

Since the back side is treated with adhesive, it is possible to attach to the cylinder.

Other than the applicable auto switches listed in "How to Order", the following auto switches can be mounted.

* Normally closed (NC= b contact), solid state switch (D-F9G/F9H type) are also available. For details, refer to page 1746.

D-□
-X□
Individual
-X□