

Power Amplifier for Electro-Pneumatic Proportional Valve

Series VEA

THE Series VEA25 □ is a dedicated amplifier that actuates an electro-pneumatic proportional valve. Basically, it performs the following three important functions

Low current command signal

The output of the D/A converter or the potentiometer can be rendered as a command signal.

High dither effect

Uses a P.W.M. (pulse width modulation) system to achieve an effective dither, thus minimizing hysteresis of the electro-pneumatic proportional valve.

Stabilizing the performance of the electro-pneumatic proportional valve

Stable performance is achieved, even in terms of impedance or supply voltage fluctuations, through the adoption of a constant current system.

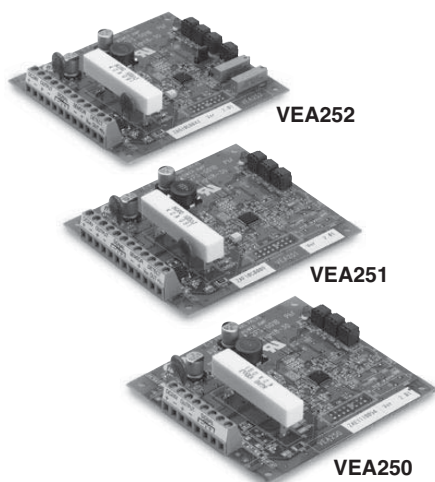

How to Order

VEA 2 5 0

Power amplifier: Printed circuit board terminal block type

Function

Symbol	Basic	Malfunction detection circuit	With feedback circuit
0	○	—	—
1	○	○	—
2	○	○	○

Voltage
24 VDC

Model

VEA250	Basic style with driving function only
VEA251	A malfunction detection circuit is added to VEA250.
VEA252	A malfunction detection circuit and a feedback circuit are added to VEA250, utilizing a positive sensor to effect various functions of high precision controls.

Basic Style Specifications: VEA250

Power supply voltage	24 VDC (Including ripple from 22 to 26 VDC)
Power consumption	Approximately 26 W
Output current range	0 to 1 A
Impedance of electro-pneumatic proportional valve	13 to 18.5 Ω (1 A F.S.)
Externally set input impedance	100 kΩ or more
Externally set input voltage	0 to 5 V
External potentiometer	10 kΩ (1/8 W or more): not provided
Step response	0.06 s or less (1 A, 95%)
Dither frequency adjustable range (DITHER)	120 to 180 Hz (140 Hz when delivered)
Zero adjustable range (NULL)	0 to 500 mA (0 mA when delivered)
Gain adjustable range (GAIN)	500 mA to 1 A for input voltage 5 V (1 A when delivered)
Electric linearity	± 1% or less (1 A F.S.)
Fluctuation to impedance	1% or less for 13 to 18.5 Ω (1 A F.S.)
Fluctuation to power supply	± 1% or less for 22 to 26 VDC (1 A F.S.)
Fluctuation to temperature	± 2% or less for 25°C ± 25°C (1 A F.S.)
Operating temperature range	0 to 50°C
Relative humidity range	25 to 85%
Vibration resistance	19.6m/s ² or less(50Hz)
Storage conditions	No condensation, Relative humidity: 25 to 85%
Weight	0.1 kg

With Malfunction Detection Circuit: VEA251 (Same main features as VEA250)

Detection capabilities	Breakage of output cable/power source cable
Output type	Open collector output/Turned off at breakage
Power source required for detecting circuit	24 VDC, 100 mA(MAX)
Weight	0.1 kg

With Feedback Circuit: VEA252 (Same main features as VEA250/251)

Sensor feedback voltage	Recommended range 0 to 5 V
Input impedance	100 kΩ or more
Pre-amplifier-gain	0.2 to 100(100 when delivered)
Integral action time (DELAY ADJ)	0 to 20 s
Derivative action time	0 to 2 s
Weight	0.1 kg

Series VEA

Circuit Diagram

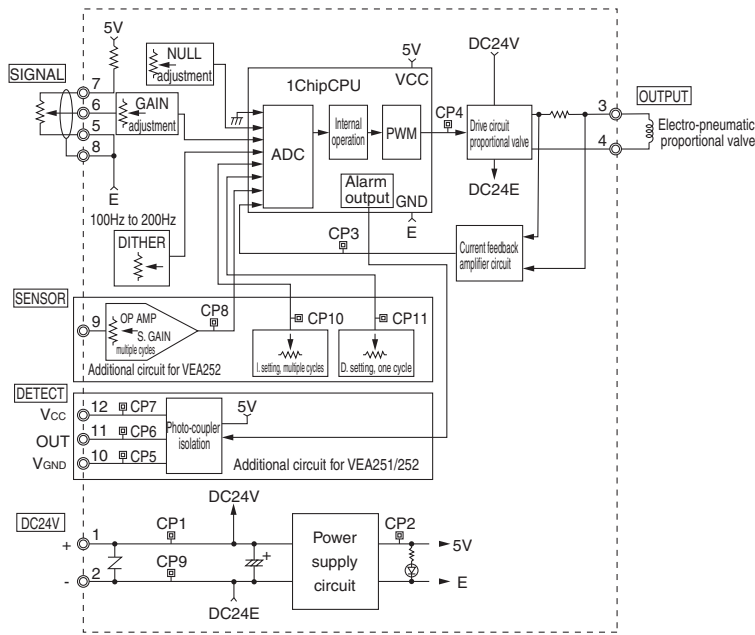

Dimensions

VEA250

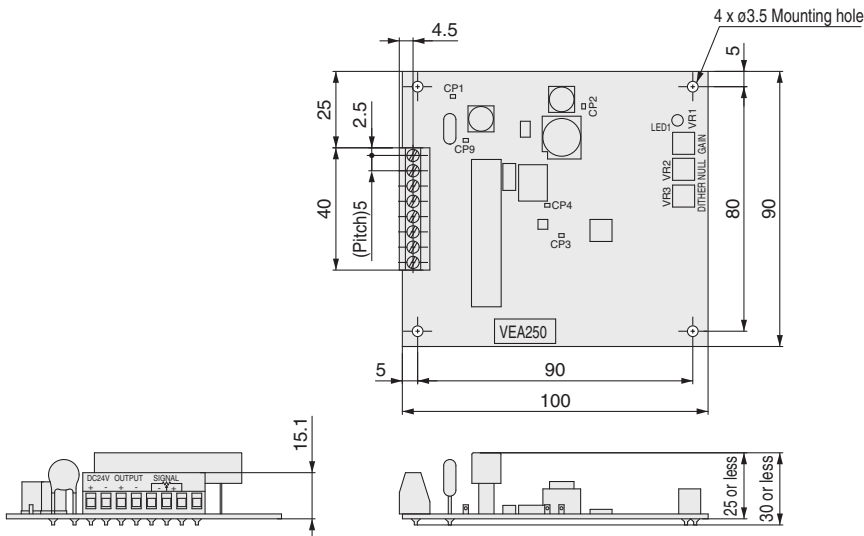

VEA251/252

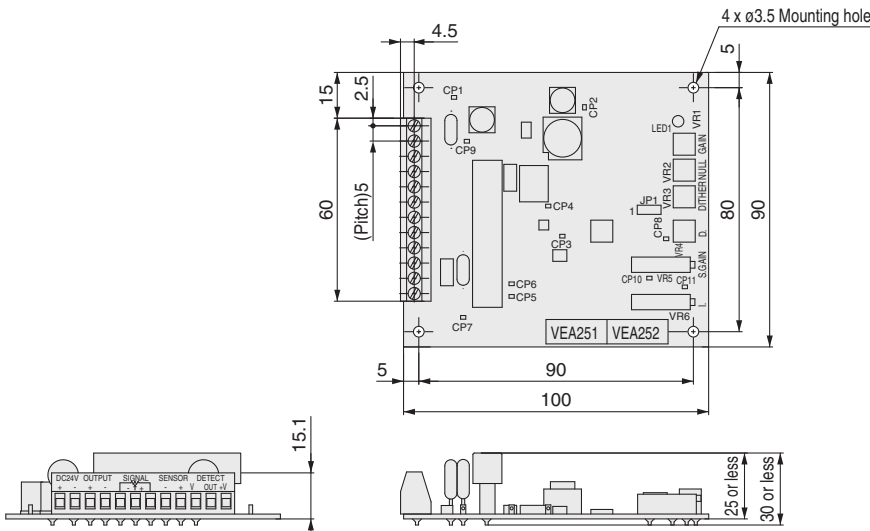

⚠ Precautions

Be sure to read before handling. Refer to front matter 43 for Safety Instructions and pages 365 to 369 for Precautions on every series.

⚠ Warning

- Some elements (such as a 10 W cement resistor) generate heat as part of their function. Therefore, when installing the power amplifier, be aware of the heat that is radiated.

⚠ Caution

- Twist and solder the end of a lead wire before connecting it.
- Separate the wiring into the 24 VDC, OUTPUT, SIGNAL, SENSOR, and DETECT portions. In particular, shielded wires are recommended for the SIGNAL and SENSOR wires. Use lead wires that measure 0.75 mm² to 1.25 mm² in thickness for the 24 VDC, OUTPUT and 0.5 mm² for the remaining wires.
- A fuse is mounted on the power supply to protect the equipment on the secondary side and the elements on the board. Be aware that it may be broken due to reverse connection of the 24 VDC wiring or overcurrent.
- When the wires are to be installed in the control panel along with those for other types of equipment, make sure to separate the AC and DC lines (to prevent the risk of damaging the elements in the circuit due to noise). Twisting the AC lines together is an effective countermeasure against noise.
- If there is a significant amount of noise (ripple) from the power supply, provide noise protection such as a noise filter or a Z-wrap. Line filter: 250 VAC, 3 to 5 A class
Z-wrap: for 39 to 47 VDC operation

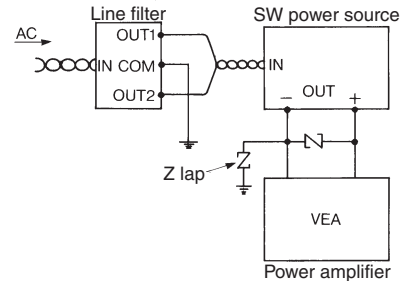

- If the feed back circuit of the VEA252 will not be used, insert jumper pin J1 on the board on the "1" side. This will disable the feedback circuit, and the VEA252 will assume the same function as that of the VEA251. When inserting the jumper pin J1 in "2" side, activate a feedback signal from the sensor. If the feedback signal is not activated, the current over 1A is output and the valve will not operate even if the externally-set input voltage is changed.
- For details about each trimmer position and adjustment procedures, refer to the Operation Manual.

Mounting

⚠ Caution

One amplifier

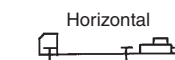

Multiple amplifiers

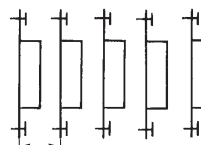

Vertical



Vertical placement promotes air convection, resulting in improved heat dissipation.

Mount at least 40 mm apart

External Connection

Basic style: VEA250

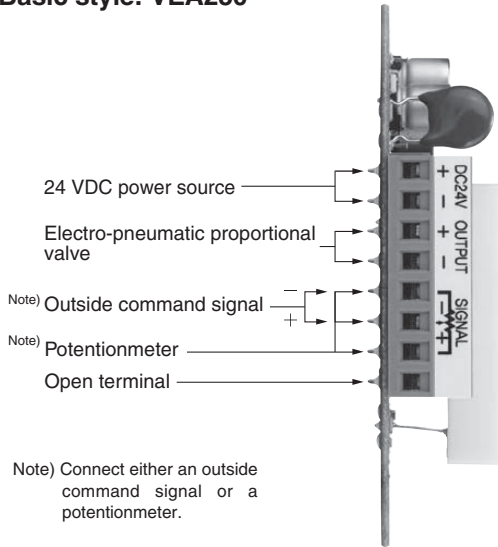

With malfunction detection circuit: VEA251

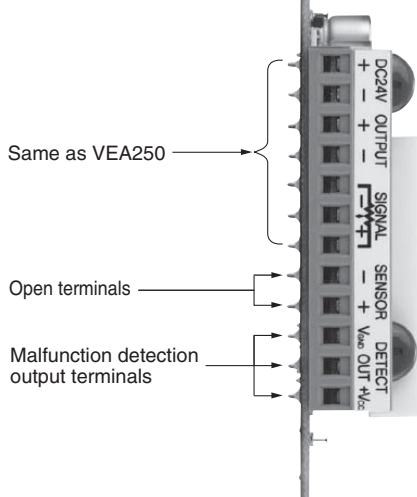

With feedback circuit: VEA252

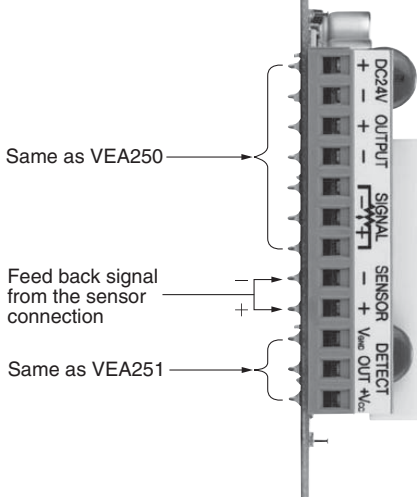

Application Example of Amplifier with Malfunction Detection Circuit

The malfunction detection circuit informs control equipment such as PCs that a short circuit or power supply cut has occurred using a photo coupler insulation open collector circuit, which will be open when malfunction occurs.

The malfunction detection circuit is not a protection circuit, it is rather recommended to interlock the system or to stop supplying power to a power amplifier in order to prevent accidents, when any malfunction is detected.

After solving the cause of a malfunction, restart the power amplifier.

Example for safety circuit

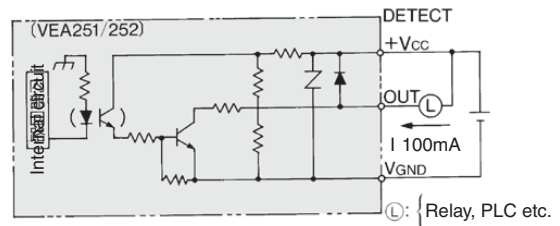

A safety circuit for the entire system is provided through the use of relays and sequence controllers as a safety measure in case the electro-pneumatic proportional valve does not operate due to an open circuit.

Example for short-circuit protection circuit

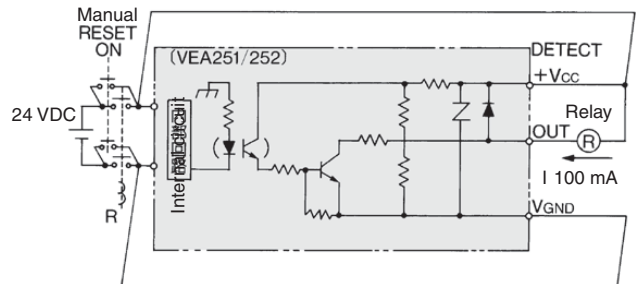

If a short circuit occurs at the current output terminal side, the power supply is shut off immediately to prevent damage to the output circuit of the power amplifier. The manual ^{RESET} switch is to be pressed to start or restart.

ARJ

AR425 to 935

ARX

AMR

ARM

ARP

IR

IRV

VEX

SRH

SRP

SRF

VCHR

ITV

IC

ITVX

PVQ

VEF VEP

VER

VEA

VY1

VBA VBAT

AP100