

# Series 11-/12- 21-/22- **CXSJ** Dual rod cylinder/Compact type $\varnothing 6, \varnothing 10$

## How to Order



### • Clean series

11	Vacuum suction type	CXSJM, CXSJL
12	Relief type (with specially treated sliding parts)	CXSJL

**11** — **CXS** **J** **L** **6** — **50** — **M9B** **S**

**21** — **CXS** **J** **L** **6** — **50** — **M9B** **S**

Copper, fluorine and silicone-free + low particle generation

21	Relief type	CXSJL
22	Vacuum suction type	CXSJL

Compact Cylinder

### • Bearing type

<b>M</b>	Slide Bearing
<b>L</b>	Ball bushing bearing

### • Number of auto switches

<b>Nil</b>	2 pcs.
<b>S</b>	1 pc.
<b>n</b>	n pcs.

### • Type of auto switch

<b>Nil</b>	Without auto switch (Built-in magnet)
------------	---------------------------------------

\* Select the applicable auto switch from the table below.

### • Bore size / Stroke (mm)

Bore size	Standard stroke
<b>6</b>	10, 20, 30, 40, 50
<b>10</b>	10, 20, 30, 40, 50

## Auto switch specifications (Refer to Best Pneumatics No. 7 to 12 for detailed specifications and auto switches not in the following table.)

Style	Special function	Electrical entry	Indicator light	Wiring (Output)	Load voltage			Auto switch model	Lead wire length (m)*			Applicable load	
					DC	AC	Electrical entry direction		0.5 Nil	3 (L)	5 (Z)		
Reed switch	—	Grommet	Yes	2-wire	24 V	12 V	100 V	A93	●	●	—	—	Relay, PLC
Solid state switch	—	Grommet	Yes	3-wire (NPN)	24 V	12 V	—	M9N	●	●	—	—	Relay, PLC
				2-wire		12 V							

\* Lead wire symbol 0.5 m.....Nil (Example) A93  
3 m.....L A93L

Refer to applicable auto switch list — Page 182.

PLC: Programmable Logic Controller

## Specifications

<b>Bore size mm</b>	6	10
<b>Fluid</b>	Air (Non-lube)	
<b>Proof pressure</b>	1.05 MPa	
<b>Max. operating pressure</b>	0.7 MPa	
<b>Min. operating pressure</b>	0.15 MPa	0.1 MPa
<b>Ambient and fluid temperature</b>	-10°C to 60°C (With no condensation)	
<b>Piston speed</b>	30 to 400 mm/s	
<b>Cushion</b>	Rubber bumper	
<b>Stroke adjustable range</b>	0 to -5 mm compared to the standard stroke	
<b>Port size</b>	M3 x 0.5	M5 x 0.8
<b>Grease</b>	11-/12-: Fluorine grease 21-/22-: Lithium soap base grease	
<b>Particle generation grade</b> (Refer to front matter pages 13 to 22 for details.)	12-: Grade 2, 21-: Grade 3 11-/22-: Grade 1	

\*The maximum piston speed shown in the table above applies to the extension side.  
The maximum piston speed for retraction is approximately 70% that of extension.

## Suction flow rate of vacuum suction type (Reference values)

Size	Suction flow rate L/min (ANR)
6	7
10	15

## Auto switches / Proper mounting positions for stroke end detection

11-**CXSJ**□6 / <sup>21-</sup>**CXSJ**□6

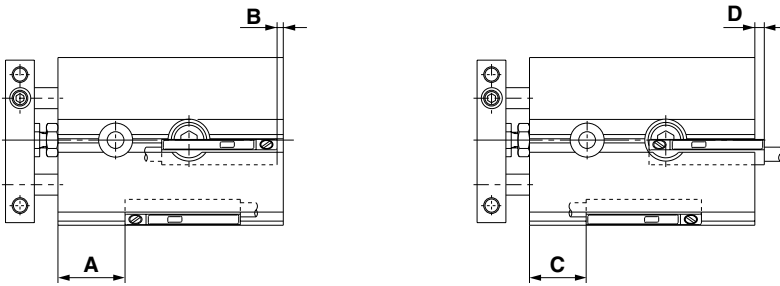

(mm)		
Symbol	D-A93	D-M9□
<b>A</b>	19(20)	23(24)
<b>B</b> <sup>Note 1)</sup>	—	2(1)
<b>C</b>	14.5(15.5)	13(11.5)
<b>D</b>	6.5(7.5)	8(9)

Note 1) The above mentioned values are indicated as a guide for auto switch mounting position for stroke end detection. When actually mounting an auto switch, adjust the position after confirming the operating state of the auto switch.

Note 2) For D-A93, only outward electrical entry (D dimension) is available.

Note 3) Dimensions in parentheses apply to 12-CXSJ□6.

11-**CXSJ**□10 / <sup>21-</sup>**CXSJ**□10

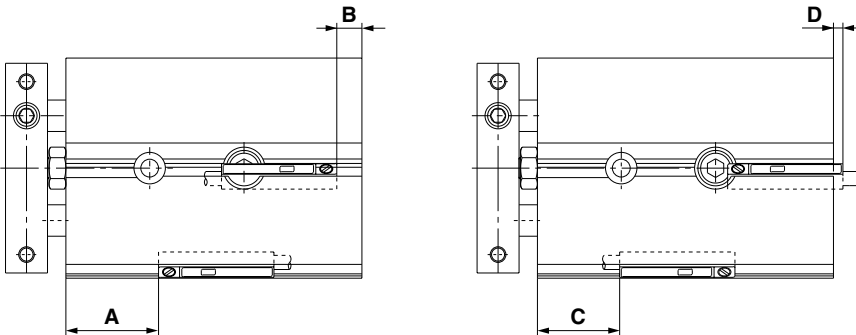

(mm)		
Symbol	D-A93	D-M9□
<b>A</b>	30 (31.5)	34(35.5)
<b>B</b> <sup>Note 1)</sup>	—	3.5(2)
<b>C</b>	25.5 (27)	24(25.5)
<b>D</b>	5 (6.5)	6.5(8)

Note 1) The above mentioned values are indicated as a guide for auto switch mounting position for stroke end detection. When actually mounting an auto switch, adjust the position after confirming the operating state of the auto switch.

Note 2) For D-A93, only outward electrical entry (D dimension) is available.

Note 3) Dimensions in parentheses apply to 12-CXSJ□10.

### Auto switch mounting dimensions

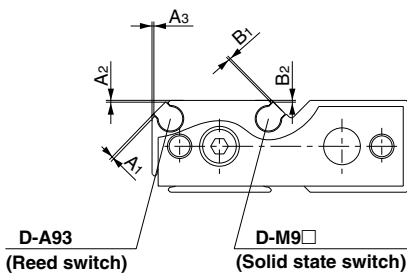

(mm)		
Auto switch model	Symbol	Bore size
		6, 10
<b>D-A93</b>	A1	0.4
	A2, A3	0.3
	B1	0.4
<b>D-M9□</b>	B2	0.3



## Specific product precautions

Be sure to read before handling.

### Mounting

Adjust the bolt holder with a hexagon wrench 3mm in width across flats so that it does not protrude from the cylinder surface (approx. 0.5mm depth from the cylinder surface to the top of the holder).

If the bolt holder is not properly adjusted, it can interfere with the switch rail, hindering the auto switch mounting.

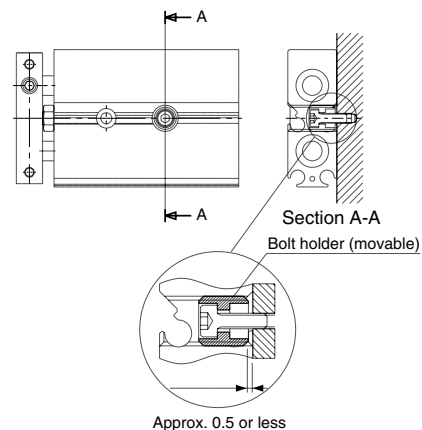

Dimensions / ø6

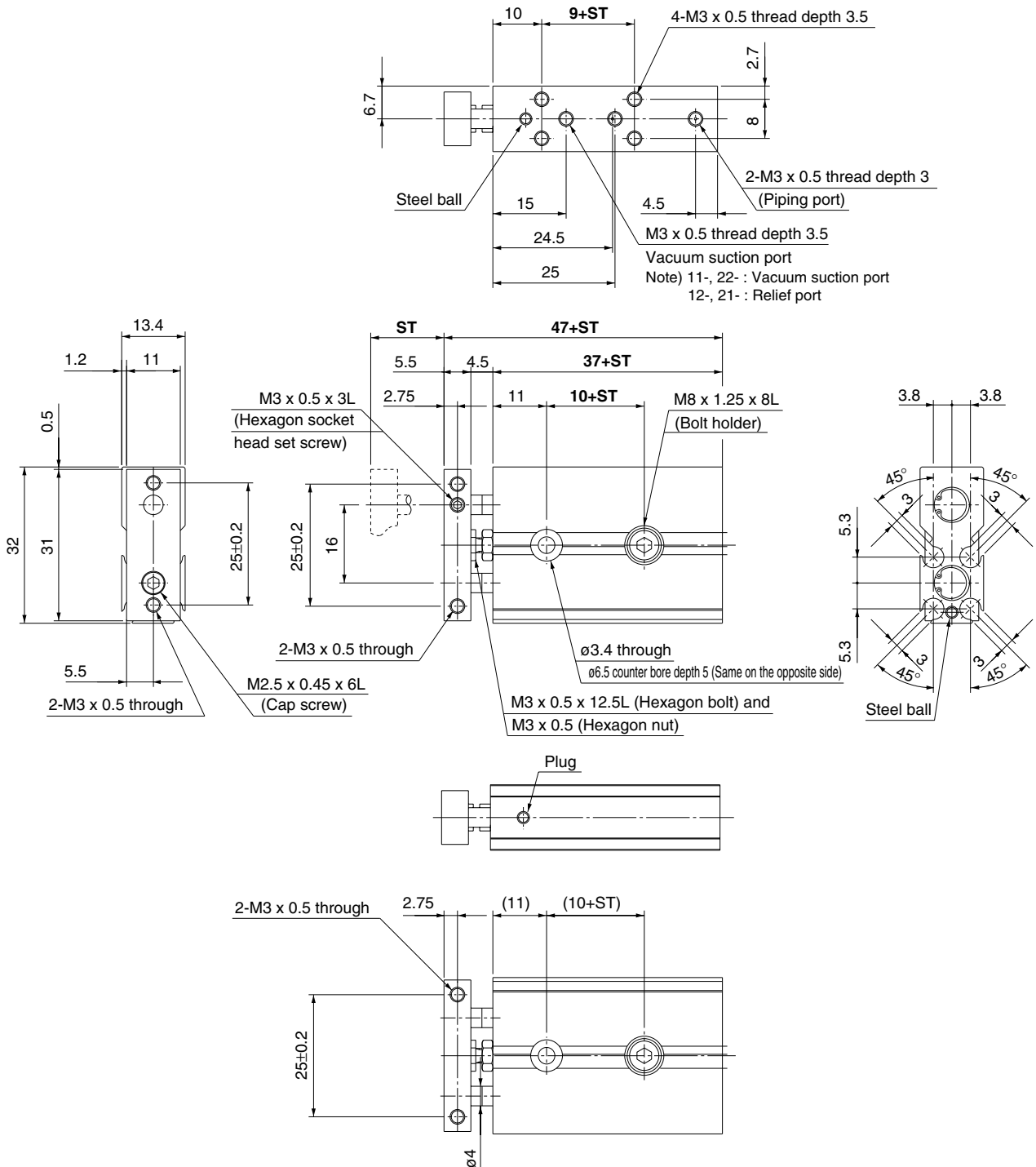

Part no.	ST	9+ST	10+ST	37+ST	47+ST
11-22: <b>CXSJ</b> □6-10	10	19	20	47	57
11-22: <b>CXSJ</b> □6-20	20	29	30	57	67
11-22: <b>CXSJ</b> □6-30	30	39	40	67	77
11-22: <b>CXSJ</b> □6-40	40	49	50	77	87
11-22: <b>CXSJ</b> □6-50	50	59	60	87	97

