

# Single Axis Electric Actuator

## Series LJ1H

### High Rigidity Direct Acting Guide



Series	Motor type	Guide type	Mounting orientation	Model	Lead screw lead mm		Page
					Ground ball screw	Rolled ball screw	
LJ1H	Standard motor	High rigidity direct acting guide	Horizontal	LJ1H10	12	12	Page 790 to
				LJ1H20	10 20	10 20	Page 794 to
				LJ1H30	25	25	Page 802 to
			Vertical	LJ1H10	8 12	8 12	Page 806 to
				LJ1H20	5 10	5 10	Page 814 to
				LJ1H30	10	10	Page 822 to

- Options ————— Page 826
- Construction ————— Page 827 to
- Mounting ————— Page 830 to
- Deflection Data ————— Page 833

### Part Number Designations

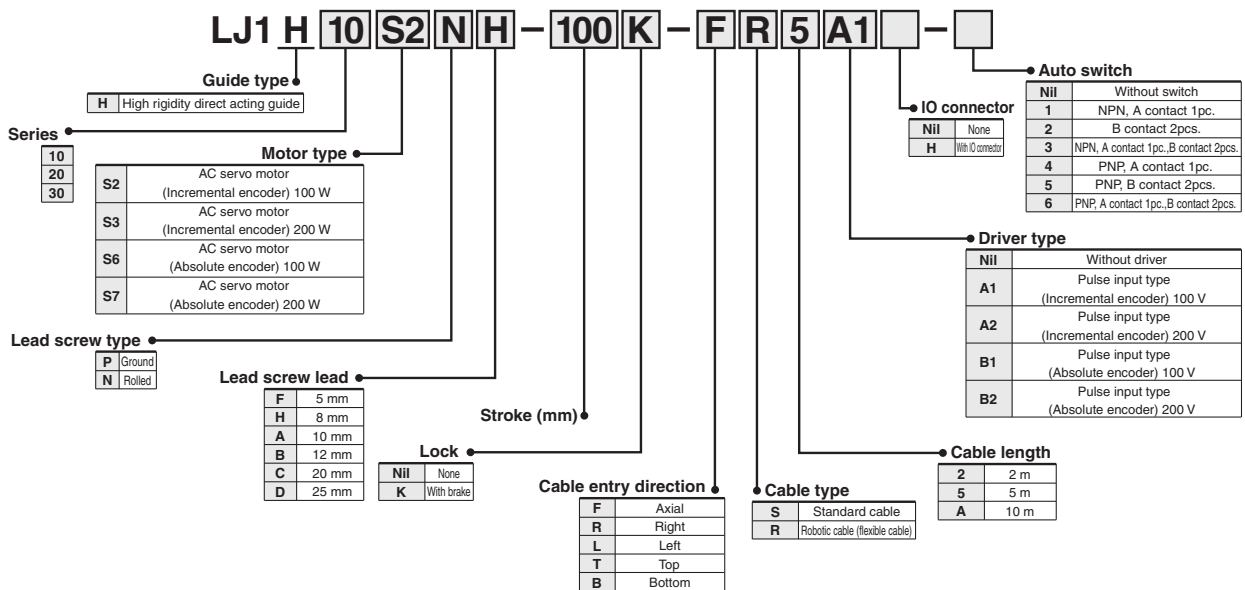

The tables above show the definition for each symbol only and cannot be used for actual model selection.

LJ1

LG1

LTF

LECS

LXF

LXP

LXS

LC6

LZ

LC3F2

D-

E-MY

# Standard Motor Horizontal Mount Series LJ1H10

Motor Output  
**100 W**

High Rigidity  
Direct Acting  
Guide

Ground Ball Screw  
**∅12 mm/12 mm lead**



## How to Order

**LJ1H10 S2 PB - 300 - F R 2 A1**

**Motor type**

<b>S2</b>	AC servo motor (Incremental encoder) 100 W
<b>S6</b>	AC servo motor (Absolute encoder) 100 W

**Stroke (mm)**  
Refer to the standard stroke.

**Cable entry direction**

<b>F</b>	Axial
<b>R</b>	Right
<b>L</b>	Left
<b>T</b>	Top
<b>B</b>	Bottom

**Cable type**

<b>S</b>	Standard cable
<b>R</b>	Robotic cable (flexible cable)

**Cable length**

<b>2</b>	2 m
<b>5</b>	5 m
<b>A</b>	10 m

**IO connector**

<b>Nil</b>	None
<b>H</b>	With IO connector

**Auto switch**

<b>Nil</b>	Without switch
<b>1</b>	NPN, A contact 1pc.
<b>2</b>	NPN, B contact 2pcs.
<b>3</b>	NPN, A contact 1pc., B contact 2pcs.
<b>4</b>	PNP, A contact 1pc.
<b>5</b>	PNP, B contact 2pcs.
<b>6</b>	PNP, A contact 1pc., B contact 2pcs.

**Driver type**

<b>Nil</b>	Without driver
<b>A1</b>	Pulse input type (Incremental encoder) 100 V
<b>A2</b>	Pulse input type (Incremental encoder) 200 V
<b>B1</b>	Pulse input type (Absolute encoder) 100 V
<b>B2</b>	Pulse input type (Absolute encoder) 200 V

## Specifications

Standard stroke (mm)		100	200	300	400	500
Performance	Body weight (kg)	5.2	6.0	6.8	7.5	8.3
	Operating temperature range (°C)	5 to 40 (No condensation)				
	Work load (kg)	10				
	Maximum speed (mm/s)	600				
	Positioning repeatability (mm)	±0.02				
Main parts	Motor	AC servo motor (100 W)				
	Encoder	Incremental system/Absolute type				
	Lead screw	Ground ball screw ∅12 mm, 12 mm lead				
	Guide	High rigidity direct acting guide				
	Motor/Screw connection	With coupling				
Driver	Model	LECS□□-□ (Refer to page 885 for details.)				

## Allowable Moment (N·m)

### Allowable static moment

Pitching	10.2
Rolling	12.8
Yawing	10.2

**m** : Transfer load (kg)  
**a** : Workpiece acceleration (mm/s<sup>2</sup>)  
**Me** : Dynamic moment  
**L** : Overhang to workpiece center of gravity (mm)

### Allowable dynamic moment

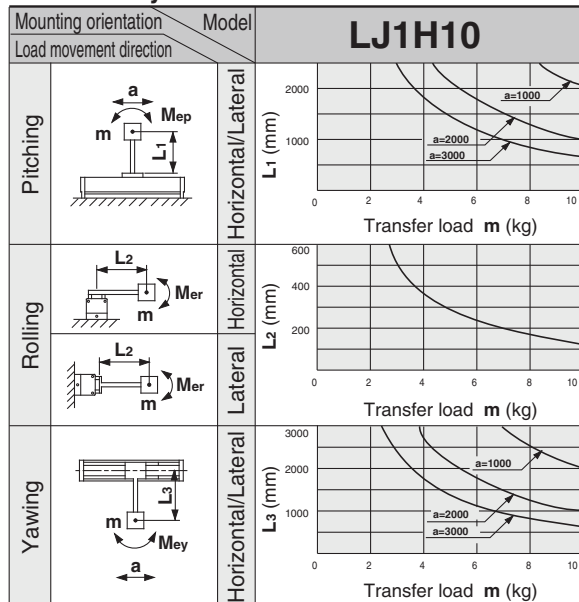

Refer to page 833 for deflection data.

## Investigation of the regeneration option

Depending on the conditions (speed, addition-subtraction speed, down time, load, etc.), the regeneration option may be required. The results of consideration in each case of maximum load or half load for the product specification are below. Please consult SMC when considering the necessity of the regeneration option.

### Maximum load

Driver type	Regeneration option model
<b>A1</b>	Not required.
<b>A2</b>	Not required.
<b>B1</b>	Not required.
<b>B2</b>	Not required.

### Half load

Driver type	Regeneration option model
<b>A1</b>	Not required.
<b>A2</b>	Not required.
<b>B1</b>	Not required.
<b>B2</b>	Not required.

**Dimensions/LJ1H10□PB**

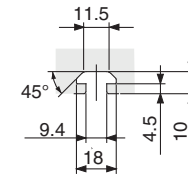
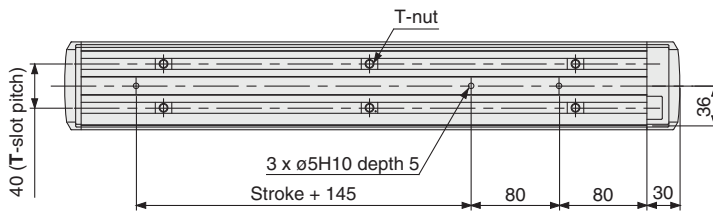
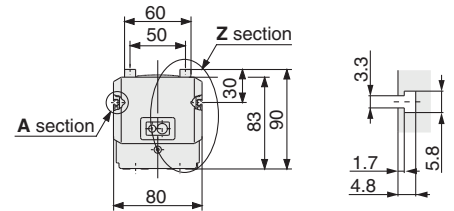
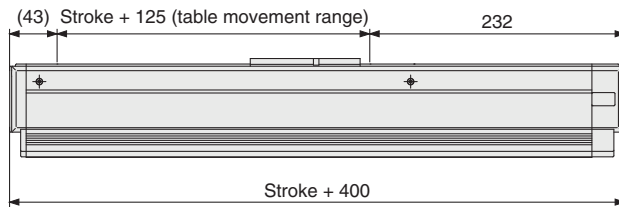
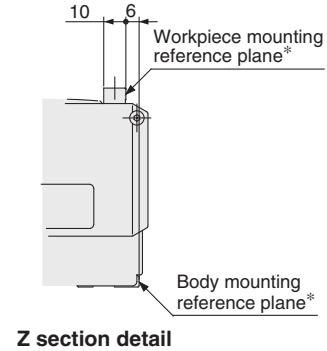
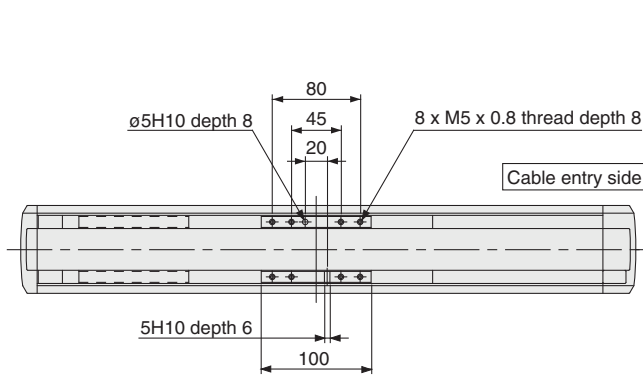

**T-slot dimensions**

\* The body mounting reference plane and workpiece mounting reference plane should be used as standards when mounting onto equipment. Refer to pages starting with 830 for mounting.

**Positioning Time Guide**

		Positioning time (sec.)				
		1	10	100	250	500
Speed (mm/s)	10	0.4	1.3	10.3	25.3	50.3
	100	0.4	0.5	1.4	2.9	5.4
	300	0.4	0.5	0.8	1.3	2.1
	600	0.4	0.5	0.7	1.0	1.4

\* Values will vary slightly depending on the operating conditions.

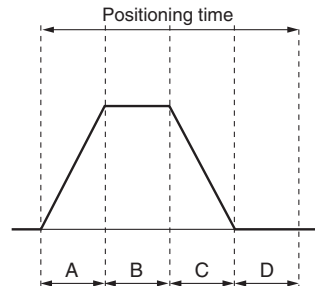

A: Acceleration time  
 B: Constant velocity time  
 C: Deceleration time  
 D: Resting time (0.3 sec.)  
 Maximum acceleration: 3000 mm/s<sup>2</sup>

**LJ1**

**LG1**

**LTF**

**LECS□**

**LXF**

**LXP**

**LXS**

**LC6□**

**LZ□**

**LC3F2**

**D-□**

**E-MY**

# Standard Motor Horizontal Mount Series LJ1H10

Motor Output  
**100 W**

High Rigidity  
Direct Acting  
Guide

Rolled Ball Screw  
**∅12 mm/12 mm lead**



## How to Order

**LJ1H10 S2 NB - 300 - F R 2 A1**

**Motor type**

S2	AC servo motor (Incremental encoder) 100 W
S6	AC servo motor (Absolute encoder) 100 W

**Stroke (mm)**  
Refer to the standard stroke.

**Cable entry direction**

F	Axial
R	Right
L	Left
T	Top
B	Bottom

**Cable type**

S	Standard cable
R	Robotic cable (flexible cable)

**Cable length**

2	2 m
5	5 m
A	10 m

**IO connector**

Nil	None
H	With IO connector

**Auto switch**

Nil	Without switch
1	NPN, A contact 1pc.
2	B contact 2pcs.
3	NPN, A contact 1pc., B contact 2pcs.
4	PNP, A contact 1pc.
5	PNP, B contact 2pcs.
6	PNP, A contact 1pc., B contact 2pcs.

**Driver type**

Nil	Without driver
A1	Pulse input type (Incremental encoder) 100 V
A2	Pulse input type (Incremental encoder) 200 V
B1	Pulse input type (Absolute encoder) 100 V
B2	Pulse input type (Absolute encoder) 200 V

**Cable entry direction**

## Specifications

Standard stroke (mm)		100	200	300	400	500
Performance	Body weight (kg)	5.2	6.0	6.8	7.5	8.3
	Operating temperature range (°C)	5 to 40 (No condensation)				
	Work load (kg)	10				
	Maximum speed (mm/s)	600				
	Positioning repeatability (mm)	±0.05				
Main parts	Motor	AC servo motor (100 W)				
	Encoder	Incremental system/Absolute type				
	Lead screw	Ground ball screw ∅12 mm, 12 mm lead				
	Guide	High rigidity direct acting guide				
	Motor/Screw connection	With coupling				
Driver	Model	LECS□□-□ (Refer to page 885 for details.)				

## Allowable Moment (N·m)

### Allowable static moment

Pitching	10.2
Rolling	12.8
Yawing	10.2

**m** : Transfer load (kg)  
**a** : Workpiece acceleration (mm/s<sup>2</sup>)  
**Me** : Dynamic moment  
**L** : Overhang to workpiece center of gravity (mm)

### Allowable dynamic moment

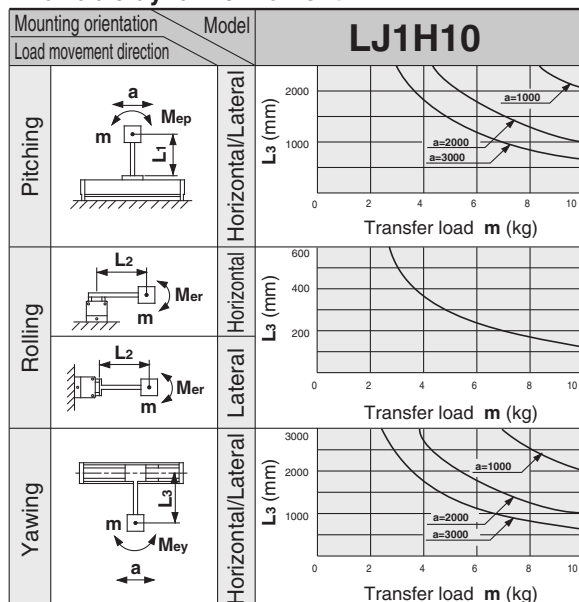

Refer to page 833 for deflection data.

## Investigation of the regeneration option

Depending on the conditions (speed, addition-subtraction speed, down time, load, etc.), the regeneration option may be required. The results of consideration in each case of maximum load or half load for the product specification are below. Please consult SMC when considering the necessity of the regeneration option.

### Maximum load

Driver type	Regeneration option model
A1	Not required.
A2	Not required.
B1	Not required.
B2	Not required.

### Half load

Driver type	Regeneration option model
A1	Not required.
A2	Not required.
B1	Not required.
B2	Not required.

**Dimensions/LJ1H10□NB**

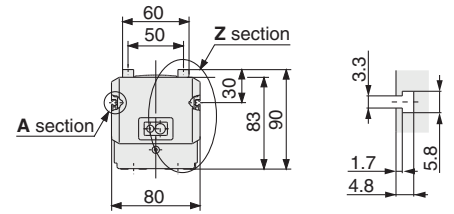
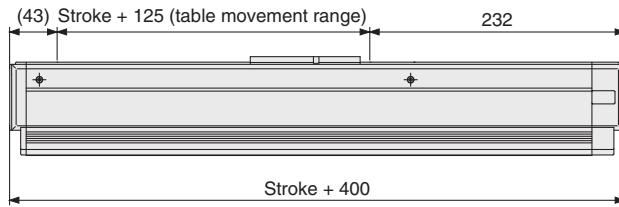
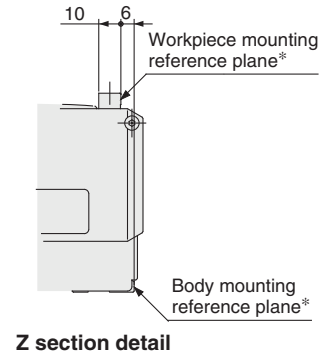
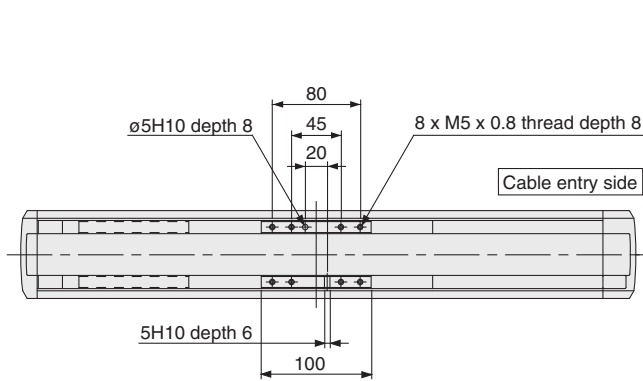

**A section detail (Switch groove)**

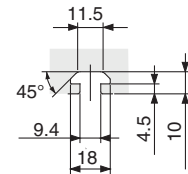
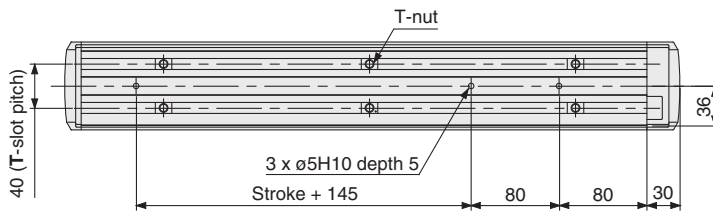

**T-slot dimensions**

\* The body mounting reference plane and workpiece mounting reference plane should be used as standards when mounting onto equipment. Refer to pages starting with 830 for mounting.

**Positioning Time Guide**

		Positioning time (sec.)				
		1	10	100	250	500
Speed (mm/s)	10	0.4	1.3	10.3	25.3	50.3
	100	0.4	0.5	1.4	2.9	5.4
	300	0.4	0.5	0.8	1.3	2.1
	600	0.4	0.5	0.7	1.0	1.4

\* Values will vary slightly depending on the operating conditions.

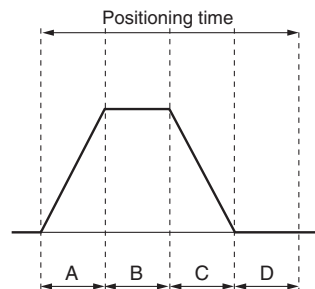

A: Acceleration time  
 B: Constant velocity time  
 C: Deceleration time  
 D: Resting time (0.3 sec.)  
 Maximum acceleration: 3000 mm/s<sup>2</sup>

- LJ1**
- LG1**
- LTF**
- LECS□**
- LXF**
- LXP**
- LXS**
- LC6□**
- LZ□**
- LC3F2**
- D-□**
- E-MY**

# Standard Motor Horizontal Mount

Motor Output  
**100 W**

High Rigidity  
Direct Acting  
Guide

Ground Ball Screw  
**∅15 mm/10 mm lead**

# Series LJ1H20



## How to Order

**LJ1H20 S2 PA - 300 - F R 2 A1**

**Motor type**

S2	AC servo motor (Incremental encoder) 100 W
S6	AC servo motor (Absolute encoder) 100 W

**Stroke (mm)**  
Refer to the standard stroke.

**Cable entry direction**

F	Axial
R	Right
L	Left
T	Top
B	Bottom

**Cable type**

S	Standard cable
R	Robotic cable (flexible cable)

**Cable length**

2	2 m
5	5 m
A	10 m

**IO connector**

Nil	None
H	With IO connector

**Auto switch**

Nil	Without switch
1	NPN, A contact 1pc.
2	NPN, B contact 2pcs.
3	NPN, A contact 1pc., B contact 2pcs.
4	PNP, A contact 1pc.
5	PNP, B contact 2pcs.
6	PNP, A contact 1pc., B contact 2pcs.

**Driver type**

Nil	Without driver
A1	Pulse input type (Incremental encoder) 100 V
A2	Pulse input type (Incremental encoder) 200 V
B1	Pulse input type (Absolute encoder) 100 V
B2	Pulse input type (Absolute encoder) 200 V

**Cable entry direction**

## Specifications

Standard stroke (mm)		100	200	300	400	500	600
Performance	Body weight (kg)	7.7	8.9	10.1	11.2	12.6	13.7
	Operating temperature range (°C)	5 to 40 (No condensation)					
	Work load (kg)	30					
	Maximum speed (mm/s)	500					
	Positioning repeatability (mm)	±0.02					
Main parts	Motor	AC servo motor (100W)					
	Encoder	Incremental system/Absolute type					
	Lead screw	Ground ball screw ∅15 mm, 10 mm lead					
	Guide	High rigidity direct acting guide					
	Motor/Screw connection	With coupling					
Driver	Model	LECS□□□□ (Refer to page 885 for details.)					

## Allowable Moment (N·m)

### Allowable static moment

Pitching	71
Rolling	83
Yawing	75

m : Transfer load (kg)  
a : Workpiece acceleration (mm/s<sup>2</sup>)  
Me : Dynamic moment  
L : Overhang to workpiece center of gravity (mm)

### Allowable dynamic moment

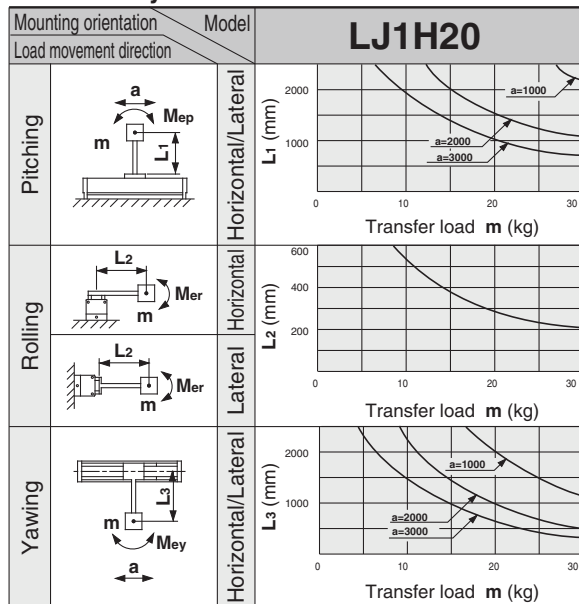

Refer to page 833 for deflection data.

## Investigation of the regeneration option

Depending on the conditions (speed, addition-subtraction speed, down time, load, etc.), the regeneration option may be required. The results of consideration in each case of maximum load or half load for the product specification are below. Please consult SMC when considering the necessity of the regeneration option.

### Maximum load

Driver type	Regeneration option model
A1	Not required.
A2	Not required.
B1	Not required.
B2	Not required.

### Half load

Driver type	Regeneration option model
A1	Not required.
A2	Not required.
B1	Not required.
B2	Not required.

## Dimensions/LJ1H20□PA

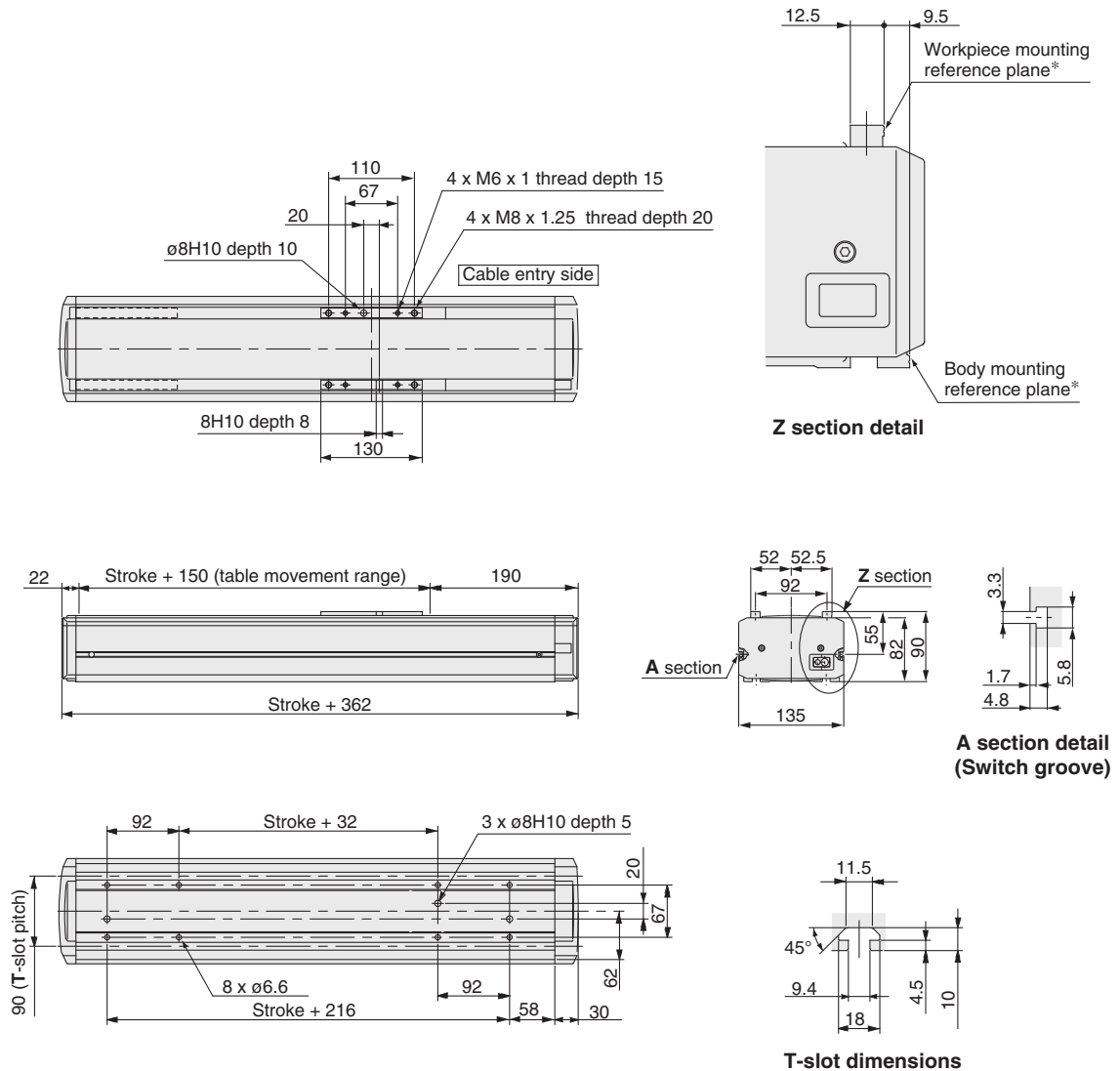

\* The body mounting reference plane and workpiece mounting reference plane should be used as standards when mounting onto equipment. Refer to pages starting with 830 for mounting.

## Positioning Time Guide

		Positioning time (sec.)				
		1	10	100	300	600
Speed (mm/s)	10	0.5	1.4	10.4	30.4	60.4
	100	0.5	0.6	1.5	3.5	6.5
	250	0.5	0.6	0.9	1.7	2.9
	500	0.5	0.6	0.8	1.2	1.8

\* Values will vary slightly depending on the operating conditions.

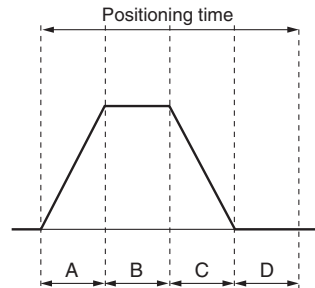

A: Acceleration time  
 B: Constant velocity time  
 C: Deceleration time  
 D: Resting time (0.4 sec.)  
 Maximum acceleration: 3000 mm/s<sup>2</sup>

LJ1

LG1

LTF

LECS□

LXF

LXP

LXS

LC6□

LZ□

LC3F2

D-□

E-MY



# Standard Motor Horizontal Mount

Motor Output  
**100 W**

High Rigidity  
Direct Acting  
Guide

Ground Ball Screw  
**∅15 mm/20 mm lead**

# Series LJ1H20



## How to Order

**LJ1H20 S2 PC - 500 - F R 2 A1**

**Motor type**

S2	AC servo motor (Incremental encoder) 100 W
S6	AC servo motor (Absolute encoder) 100 W

**Stroke (mm)**  
Refer to the standard stroke.

**Cable entry direction**

F	Axial
R	Right
L	Left
T	Top
B	Bottom

**Cable type**

S	Standard cable
R	Robotic cable (flexible cable)

**Cable length**

2	2 m
5	5 m
A	10 m

**IO connector**

Nil	None
H	With IO connector

**Auto switch**

Nil	Without switch
1	NPN, A contact 1pc.
2	NPN, B contact 2pcs.
3	NPN, A contact 1pc., B contact 2pcs.
4	PNP, A contact 1pc.
5	PNP, B contact 2pcs.
6	PNP, A contact 1pc., B contact 2pcs.

**Driver type**

Nil	Without driver
A1	Pulse input type (Incremental encoder) 100 V
A2	Pulse input type (Incremental encoder) 200 V
B1	Pulse input type (Absolute encoder) 100 V
B2	Pulse input type (Absolute encoder) 200 V

## Specifications

Standard stroke (mm)		500	600	700	800	900	1000
Performance	Body weight (kg)	12.6	13.7	14.5	15.3	17.2	18.6
	Operating temperature range (°C)	5 to 40 (No condensation)					
	Work load (kg)	30					
	Maximum speed (mm/s) <sup>Note)</sup>	1000	1000	930	740	600	500
	Positioning repeatability (mm)	±0.02					
Main parts	Motor	AC servo motor (100 W)					
	Encoder	Incremental system/Absolute type					
	Lead screw	Ground ball screw ∅15 mm, 20 mm lead					
	Guide	High rigidity direct acting guide					
	Motor/Screw connection	With coupling					
Driver	Model	LECS□□-□ (Refer to page 885 for details.)					

Note) The speed is limited by the transfer load. Refer to the maximum speeds for each transfer load on page 797.

## Allowable Moment (N·m)

### Allowable static moment

Pitching	71
Rolling	83
Yawing	75

**m** : Transfer load (kg)  
**a** : Workpiece acceleration (mm/s<sup>2</sup>)  
**Me** : Dynamic moment  
**L** : Overhang to workpiece center of gravity (mm)

### Allowable dynamic moment

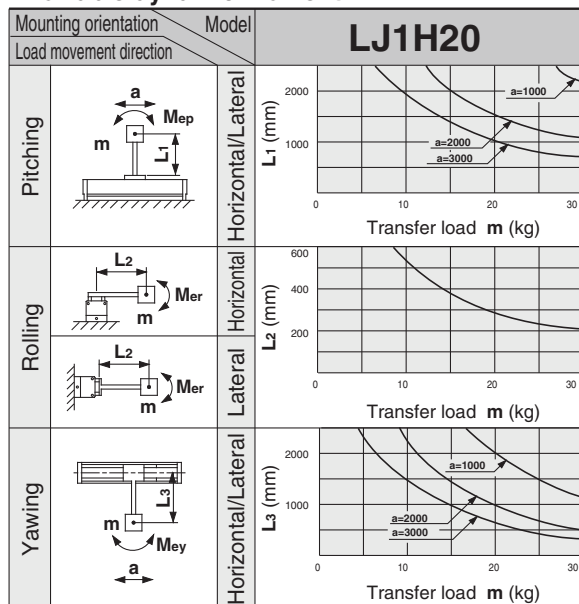

Refer to page 833 for deflection data.

## Investigation of the regeneration option

Depending on the conditions (speed, addition-subtraction speed, down time, load, etc.), the regeneration option may be required. The results of consideration in each case of maximum load or half load for the product specification are below. Please consult SMC when considering the necessity of the regeneration option.

### Maximum load

Driver type	Regeneration option model
A1	LEC-MR-RB-032
A2	Not required.
B1	LEC-MR-RB-032
B2	Not required.

### Half load

Driver type	Regeneration option model
A1	Not required.
A2	Not required.
B1	Not required.
B2	Not required.



## Dimensions/LJ1H20□PC

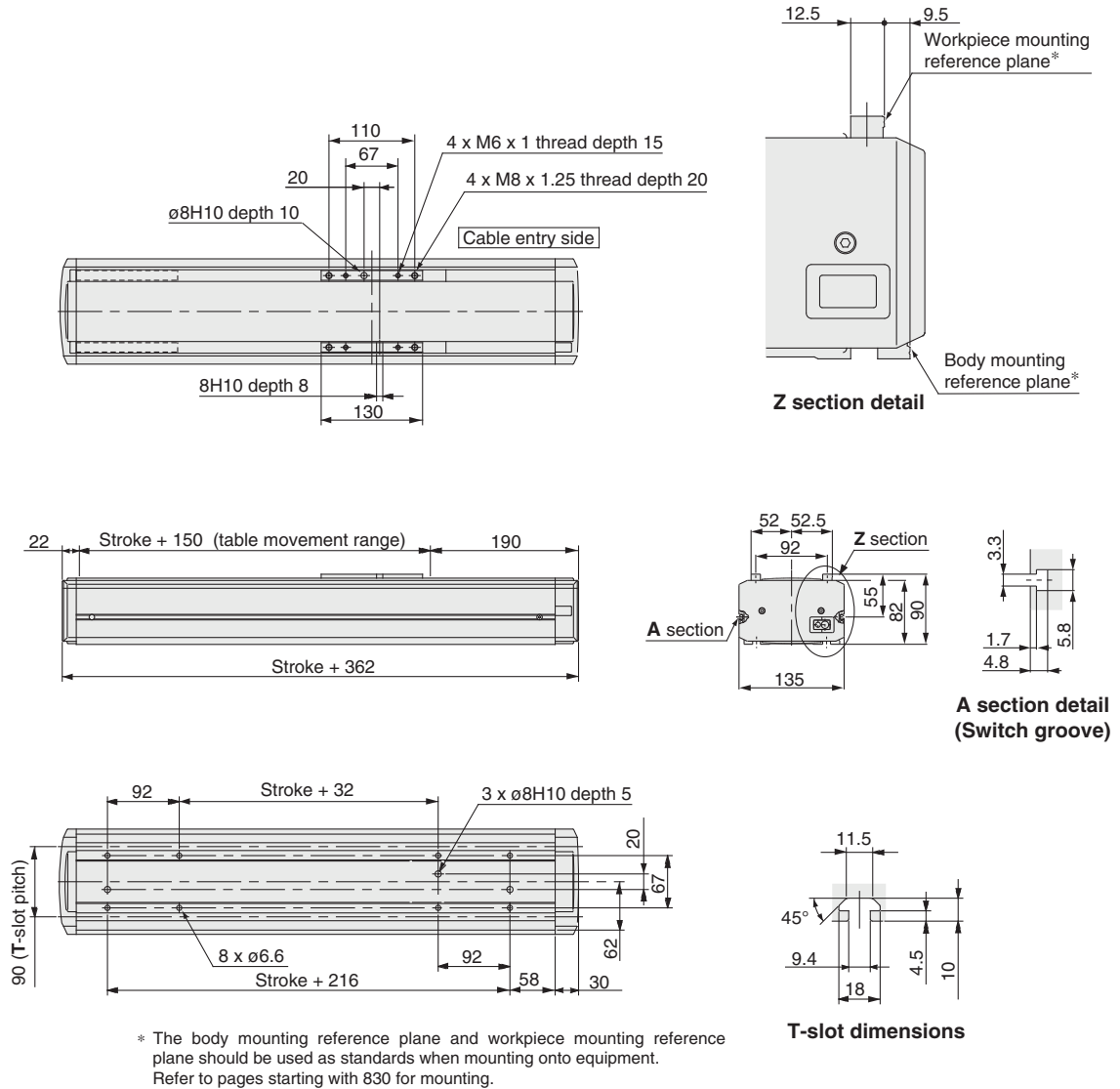

- LJ1
- LG1
- LTF
- LECS□
- LXF
- LXP
- LXS
- LC6□
- LZ□
- LC3F2
- D-□
- E-MY

## Positioning Time Guide

Positioning distance (mm)		Positioning time (sec.)				
		1	10	100	500	1000
Speed (mm/s)	10	0.6	1.5	10.5	50.5	100.5
	100	0.5	0.6	1.5	5.5	10.5
	500	0.5	0.6	0.9	1.7	2.7
	1000	0.5	0.6	0.9	1.4	1.9

\* Values will vary slightly depending on the operating conditions.

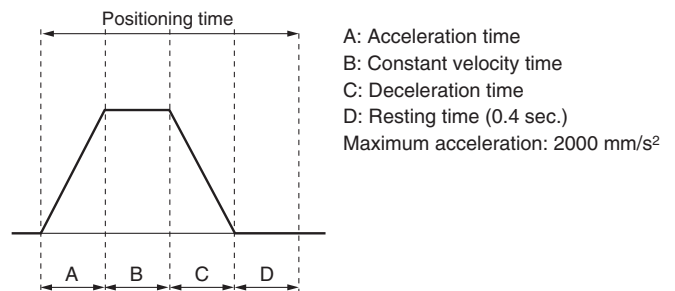

## Maximum Speeds for Each Transfer Load

Unit (mm/s)

Model	Transfer load (kg)			
	15	20	25	30
LJ1H20□PC-500-□	1000	700	500	500
LJ1H20□PC-600-□	1000	700	500	500
LJ1H20□PC-700-□	930	600	500	500
LJ1H20□PC-800-□	740	600	500	500
LJ1H20□PC-900-□	600	500	500	500
LJ1H20□PC-1000-□	500	500	500	500

# Standard Motor Horizontal Mount Series LJ1H20

Motor Output  
**100 W**

High Rigidity  
Direct Acting  
Guide

Rolled Ball Screw  
**∅15 mm/10 mm lead**



## How to Order

**LJ1H20 S2 NA - 300 - F R 2 A1**

**Motor type**

S2	AC servo motor (Incremental encoder) 100 W
S6	AC servo motor (Absolute encoder) 100 W

**Stroke (mm)**  
Refer to the standard stroke.

**Cable entry direction**

F	Axial
R	Right
L	Left
T	Top
B	Bottom

**Cable type**

S	Standard cable
R	Robotic cable (flexible cable)

**Cable length**

2	2 m
5	5 m
A	10 m

**IO connector**

Nil	None
H	With IO connector

**Auto switch**

Nil	Without switch
1	NPN, A contact 1pc.
2	NPN, B contact 2pcs.
3	NPN, A contact 1pc., B contact 2pcs.
4	PNP, A contact 1pc.
5	PNP, B contact 2pcs.
6	PNP, A contact 1pc., B contact 2pcs.

**Driver type**

Nil	Without driver
A1	Pulse input type (Incremental encoder) 100 V
A2	Pulse input type (Incremental encoder) 200 V
B1	Pulse input type (Absolute encoder) 100 V
B2	Pulse input type (Absolute encoder) 200 V

**Cable entry direction**

## Specifications

Standard stroke (mm)		100	200	300	400	500	600
Performance	Body weight (kg)	7.7	8.9	10.1	11.2	12.6	13.7
	Operating temperature range (°C)	5 to 40 (No condensation)					
	Work load (kg)	30					
	Maximum speed (mm/s)	500					
	Positioning repeatability (mm)	±0.05					
Main parts	Motor	AC servo motor (100 W)					
	Encoder	Incremental system/Absolute type					
	Lead screw	Rolled ball screw ∅15 mm, 10 mm lead					
	Guide	High rigidity direct acting guide					
	Motor/Screw connection	With coupling					
Driver	Model	LECS□□-□ (Refer to page 885 for details.)					

## Allowable Moment (N·m)

### Allowable static moment

Pitching	71
Rolling	83
Yawing	75

m : Transfer load (kg)  
a : Workpiece acceleration (mm/s<sup>2</sup>)  
Me : Dynamic moment  
L : Overhang to workpiece center of gravity (mm)

### Allowable dynamic moment

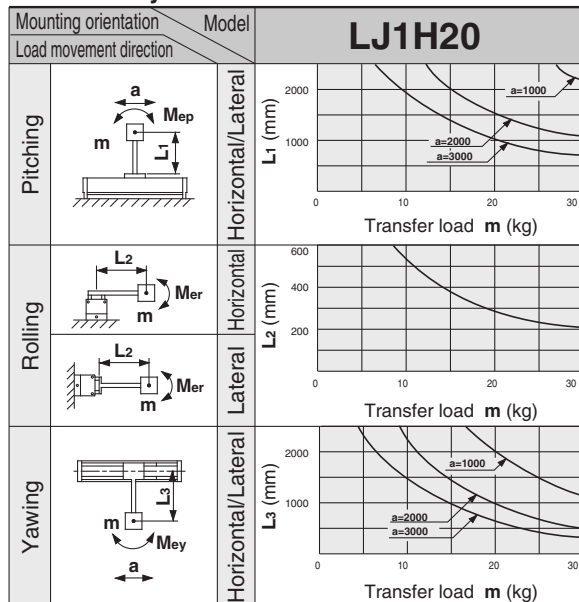

Refer to page 833 for deflection data.

## Investigation of the regeneration option

Depending on the conditions (speed, addition-subtraction speed, down time, load, etc.), the regeneration option may be required. The results of consideration in each case of maximum load or half load for the product specification are below. Please consult SMC when considering the necessity of the regeneration option.

### Maximum load

Driver type	Regeneration option model
A1	Not required.
A2	Not required.
B1	Not required.
B2	Not required.

### Half load

Driver type	Regeneration option model
A1	Not required.
A2	Not required.
B1	Not required.
B2	Not required.

## Dimensions/LJ1H20□NA

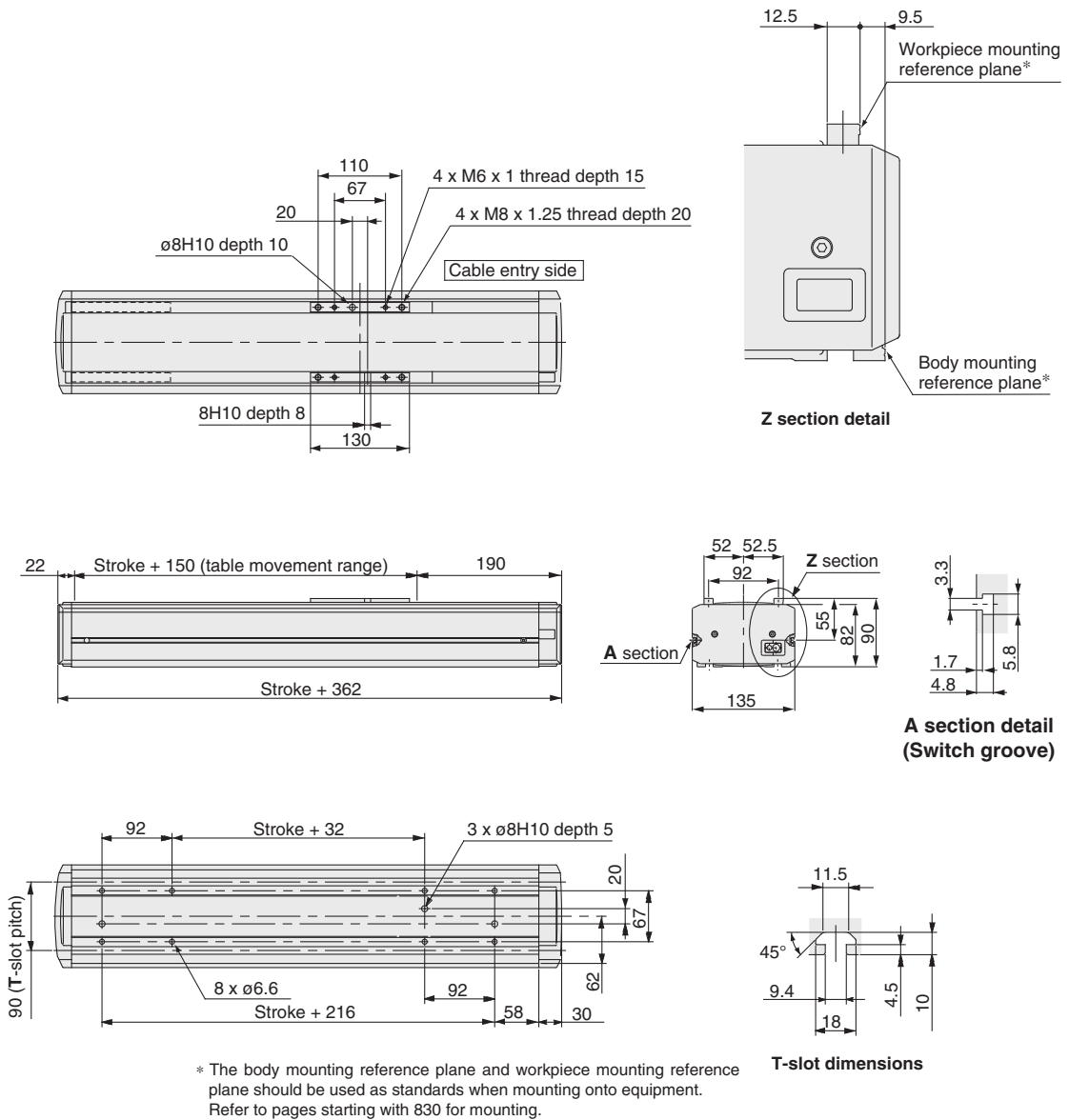

- LJ1
- LG1
- LTF
- LECS□
- LXF
- LXP
- LXS
- LC6□
- LZ□
- LC3F2
- D-□
- E-MY

## Positioning Time Guide

		Positioning time (sec.)				
		1	10	100	300	600
Speed (mm/s)	10	0.5	1.4	10.4	30.4	60.4
	100	0.5	0.6	1.5	3.5	6.5
	250	0.5	0.6	0.9	1.7	2.9
	500	0.5	0.6	0.8	1.2	1.8

\* Values will vary slightly depending on the operating conditions.

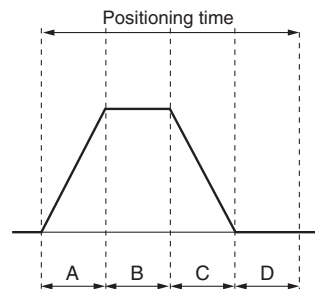

A: Acceleration time  
 B: Constant velocity time  
 C: Deceleration time  
 D: Resting time (0.4 sec.)  
 Maximum acceleration: 3000 mm/s<sup>2</sup>

# Standard Motor Horizontal Mount

Motor Output  
**100 W**

High Rigidity  
Direct Acting  
Guide

Rolled Ball Screw  
**∅15 mm/20 mm lead**

# Series LJ1H20



## How to Order

**LJ1H20 S2 NC - 500 - F R 2 A1**

**Motor type**

S2	AC servo motor (Incremental encoder) 100 W
S6	AC servo motor (Absolute encoder) 100 W

**Stroke (mm)**  
Refer to the standard stroke.

**Cable entry direction**

F	Axial
R	Right
L	Left
T	Top
B	Bottom

**Cable type**

S	Standard cable
R	Robotic cable (flexible cable)

**Cable length**

2	2 m
5	5 m
A	10 m

**IO connector**

Nil	None
H	With IO connector

**Auto switch**

Nil	Without switch
1	NPN, A contact 1pc.
2	NPN, B contact 2pcs.
3	NPN, A contact 1pc., B contact 2pcs.
4	PNP, A contact 1pc.
5	PNP, B contact 2pcs.
6	PNP, A contact 1pc., B contact 2pcs.

**Driver type**

Nil	Without driver
A1	Pulse input type (Incremental encoder) 100 V
A2	Pulse input type (Incremental encoder) 200 V
B1	Pulse input type (Absolute encoder) 100 V
B2	Pulse input type (Absolute encoder) 200 V

## Specifications

Standard stroke (mm)		500	600	700	800	900	1000
Performance	Body weight (kg)	12.6	13.7	14.5	15.3	17.2	18.6
	Operating temperature range (°C)	5 to 40 (No condensation)					
	Work load (kg)	30					
	Maximum speed (mm/s) <sup>Note)</sup>	1000	1000	930	740	600	500
	Positioning repeatability (mm)	±0.05					
Main parts	Motor	AC servo motor (100 W)					
	Encoder	Incremental system/Absolute type					
	Lead screw	Rolled ball screw ∅15 mm, 20 mm lead					
	Guide	High rigidity direct acting guide					
	Motor/Screw connection	With coupling					
Driver	Model	LECS□□-□ (Refer to page 885 for details.)					

Note) The speed is limited by the transfer load. Refer to the maximum speeds for each transfer load on page 801.

## Allowable Moment (N·m)

### Allowable static moment

Pitching	71
Rolling	83
Yawing	75

**m** : Transfer load (kg)  
**a** : Workpiece acceleration (mm/s<sup>2</sup>)  
**Me** : Dynamic moment  
**L** : Overhang to workpiece center of gravity (mm)

### Allowable dynamic moment

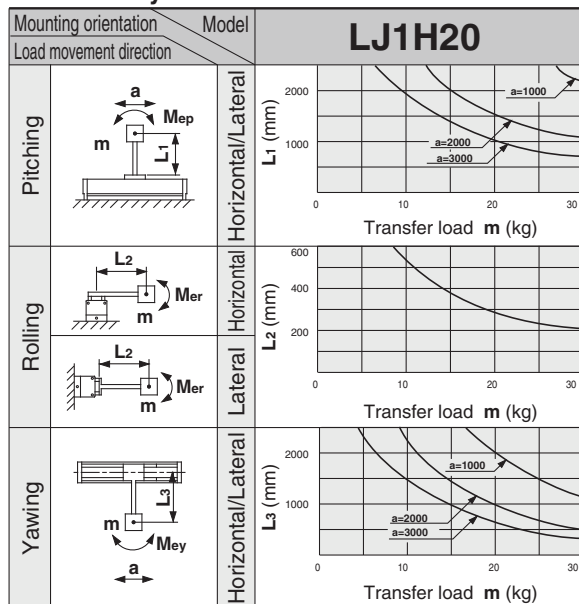

Refer to page 833 for deflection data.

## Investigation of the regeneration option

Depending on the conditions (speed, addition-subtraction speed, down time, load, etc.), the regeneration option may be required. The results of consideration in each case of maximum load or half load for the product specification are below. Please consult SMC when considering the necessity of the regeneration option.

### Maximum load

Driver type	Regeneration option model
A1	LEC-MR-RB-032
A2	Not required.
B1	LEC-MR-RB-032
B2	Not required.

### Half load

Driver type	Regeneration option model
A1	Not required.
A2	Not required.
B1	Not required.
B2	Not required.

## Dimensions/LJ1H20□NC

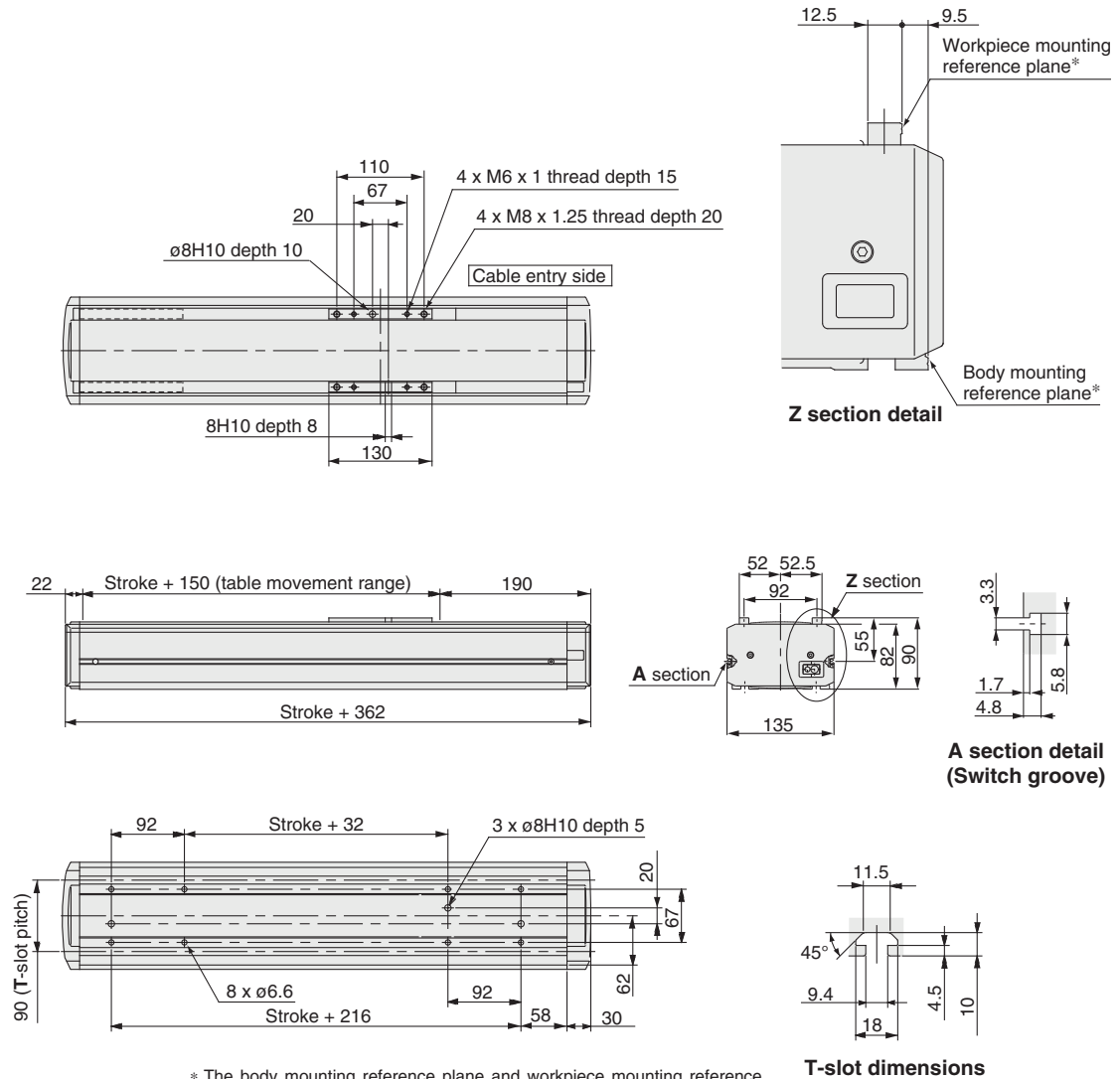

\* The body mounting reference plane and workpiece mounting reference plane should be used as standards when mounting onto equipment. Refer to pages starting with 830 for mounting.

## Positioning Time Guide

		Positioning time (sec.)				
		1	10	100	500	1000
Speed (mm/s)	10	0.6	1.5	10.5	50.5	100.5
	100	0.5	0.6	1.5	5.5	10.5
	500	0.5	0.6	0.9	1.7	2.7
	1000	0.5	0.6	0.9	1.4	1.9

\* Values will vary slightly depending on the operating conditions.

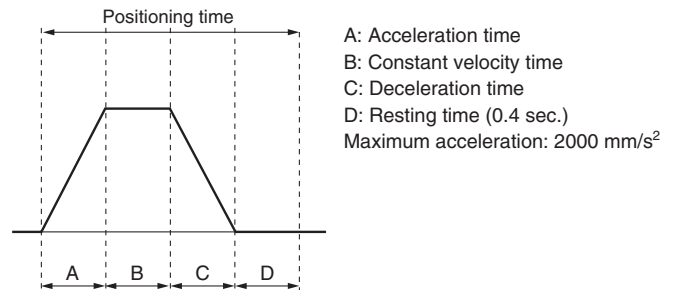

## Maximum Speeds for Each Transfer Load

Model	Transfer load (kg)			
	15	20	25	30
LJ1H20□NC-500-□	1000	700	500	500
LJ1H20□NC-600-□	1000	700	500	500
LJ1H20□NC-700-□	930	600	500	500
LJ1H20□NC-800-□	740	600	500	500
LJ1H20□NC-900-□	600	500	500	500
LJ1H20□NC-1000-□	500	500	500	500

Unit (mm/s)

# Standard Motor Horizontal Mount

Motor Output  
**200 W**

High Rigidity  
Direct Acting  
Guide

Ground Ball Screw  
**∅25 mm/25 mm lead**

# Series LJ1H30



## How to Order

**LJ1H30 S3 PD - 300 - F R 2 A1**

**Motor type**

S3	AC servo motor (Incremental encoder) 200 W
S7	AC servo motor (Absolute encoder) 200 W

**Stroke (mm)**  
Refer to the standard stroke.

**Cable entry direction**

F	Axial
R	Right
L	Left
T	Top
B	Bottom

**Cable type**

S	Standard cable
R	Robotic cable (flexible cable)

**Cable length**

2	2 m
5	5 m
A	10 m

**IO connector**

Nil	None
H	With IO connector

**Auto switch**

Nil	Without switch
1	NPN, A contact 1pc.
2	NPN, B contact 2pcs.
3	NPN, A contact 1pc., B contact 2pcs.
4	PNP, A contact 1pc.
5	PNP, B contact 2pcs.
6	PNP, A contact 1pc., B contact 2pcs.

**Driver type**

Nil	Without driver
A1	Pulse input type (Incremental encoder) 100 V
A2	Pulse input type (Incremental encoder) 200 V
B1	Pulse input type (Absolute encoder) 100 V
B2	Pulse input type (Absolute encoder) 200 V

## Specifications

Standard stroke (mm)		200	300	400	500	600	800	1000	1200	1500
Performance	Body weight (kg)	16.0	18.0	20.0	22.0	24.0	28.5	33.0	37.0	43.0
	Operating temperature range (°C)	5 to 40 (No condensation)								
	Work load (kg)	60								
	Maximum speed (mm/s) <sup>Note)</sup>	1000							700	500
	Positioning repeatability (mm)	±0.02								
Main parts	Motor	AC servo motor (200 W)								
	Encoder	Incremental system/Absolute type								
	Lead screw	Ground ball screw ∅25 mm, 25 mm lead								
	Guide	High rigidity direct acting guide								
	Motor/Screw connection	With coupling								
Driver	Model	LECS□□□ (Refer to page 885 for details.)								

Note) The speed is limited by the transfer load. Refer to the maximum speeds for each transfer load on page 803.

## Allowable Moment (N·m)

### Allowable static moment

Pitching	117
Rolling	137
Yawing	123

**m** : Transfer load (kg)  
**a** : Workpiece acceleration (mm/s<sup>2</sup>)  
**Me** : Dynamic moment  
**L** : Overhang to workpiece center of gravity (mm)

### Allowable dynamic moment

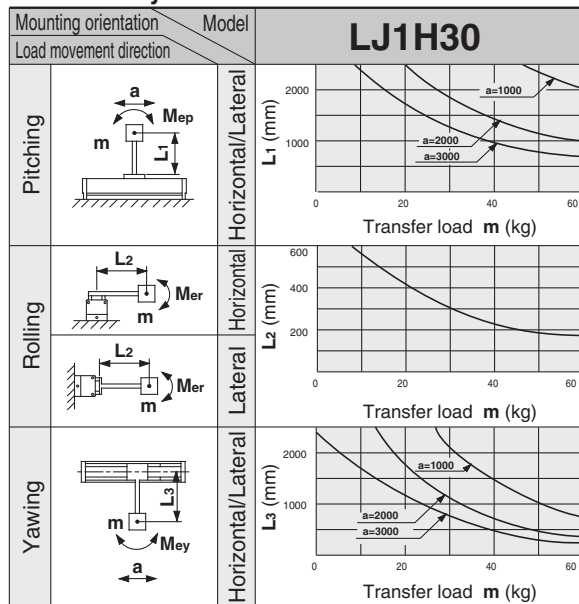

Refer to page 833 for deflection data.

## Investigation of the regeneration option

Depending on the conditions (speed, addition-subtraction speed, down time, load, etc.), the regeneration option may be required. The results of consideration in each case of maximum load or half load for the product specification are below. Please consult SMC when considering the necessity of the regeneration option.

### Maximum load

Driver type	Regeneration option model
A1	LEC-MR-RB-032
A2	Not required.
B1	LEC-MR-RB-032
B2	Not required.

### Half load

Driver type	Regeneration option model
A1	Not required.
A2	Not required.
B1	Not required.
B2	Not required.

## Dimensions/LJ1H30□PD

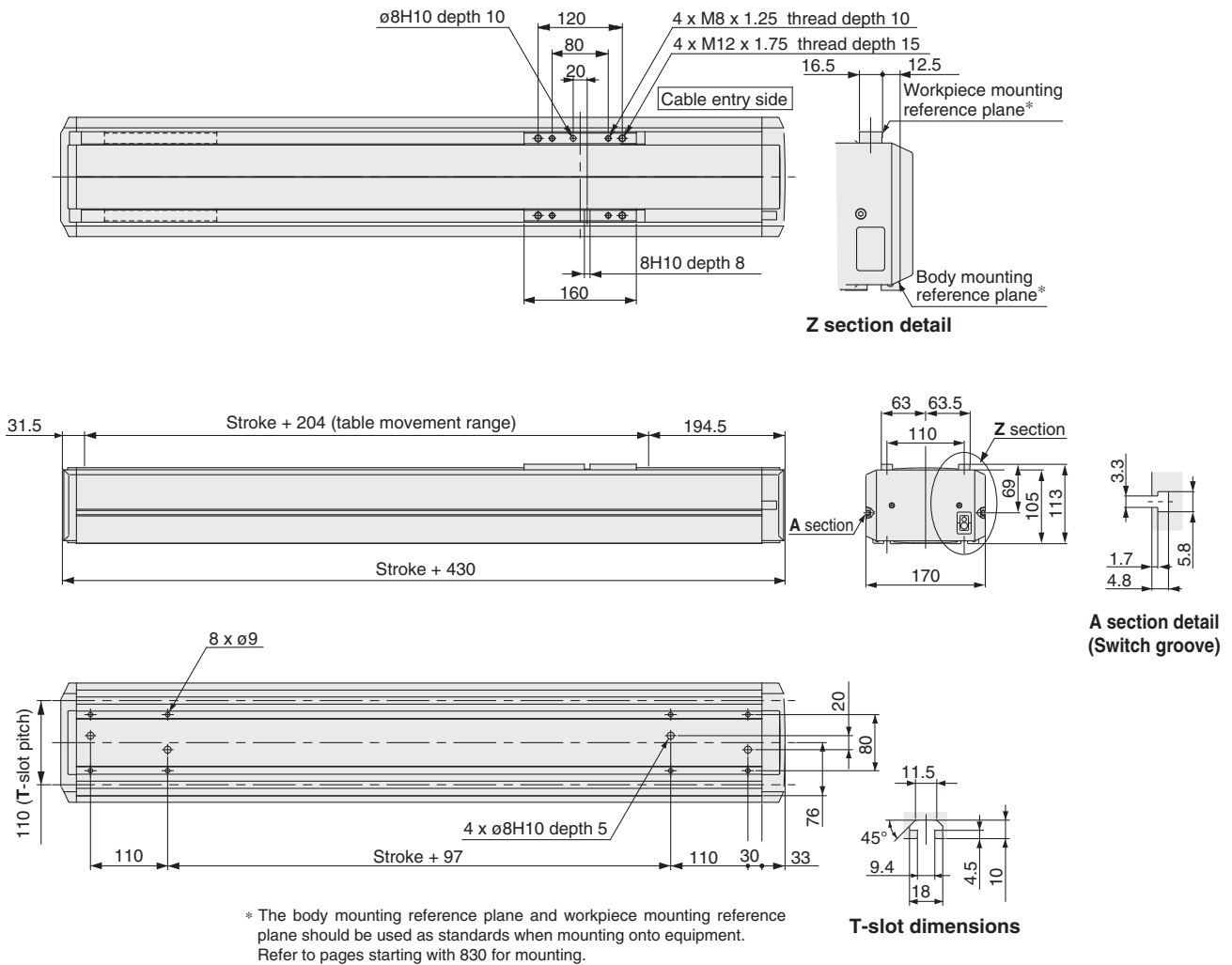

- LJ1
- LG1
- LTF
- LECS□
- LXF
- LXP
- LXS
- LC6□
- LZ□
- LC3F2
- D-□
- E-MY

## Positioning Time Guide

		Positioning time (sec.)				
		1	10	100	750	1500
Speed (mm/s)	10	1.1	2.0	11.0	76.0	151.0
	100	1.1	1.2	2.1	8.6	16.1
	500	1.1	1.2	1.4	2.7	4.2
	1000	1.1	1.2	1.4	2.1	2.9

\* Values will vary slightly depending on the operating conditions.

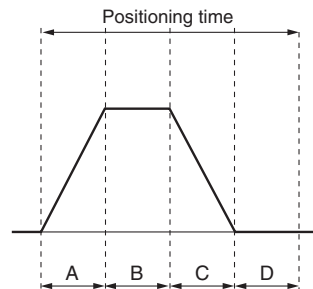

A: Acceleration time  
 B: Constant velocity time  
 C: Deceleration time  
 D: Resting time (1.0 sec.)  
 Maximum acceleration: 3000 mm/s<sup>2</sup>

## Maximum Speeds for Each Transfer Load

Unit (mm/s)

Model	Transfer load (kg)					
	10	20	30	40	50	60
LJ1H30□PD-200~1000-□	1000	1000	1000	1000	900	800
LJ1H30□PD-1200-□	700	700	700	700	700	700
LJ1H30□PD-1500-□	500	500	500	500	500	500
LJ1H30□PD-200~1000-□	1000	900	800	700	650	600
LJ1H30□PD-1200-□	700	700	700	700	650	600
LJ1H30□PD-1500-□	500	500	500	500	500	500

\* Consult SMC if outside of the above conditions.



# Standard Motor Horizontal Mount

Motor Output  
**200 W**

High Rigidity  
Direct Acting  
Guide

Rolled Ball Screw  
**∅25 mm/25 mm lead**

# Series LJ1H30



## How to Order

**LJ1H30 S3 ND - 300 - F R 2 A1**

**Motor type**

<b>S3</b>	AC servo motor (Incremental encoder) 200 W
<b>S7</b>	AC servo motor (Absolute encoder) 200 W

**Stroke (mm)**  
Refer to the standard stroke.

**Cable entry direction**

<b>F</b>	Axial
<b>R</b>	Right
<b>L</b>	Left
<b>T</b>	Top
<b>B</b>	Bottom

**Cable type**

<b>S</b>	Standard cable
<b>R</b>	Robotic cable (flexible cable)

**Cable length**

<b>2</b>	2 m
<b>5</b>	5 m
<b>A</b>	10 m

**IO connector**

<b>Nil</b>	None
<b>H</b>	With IO connector

**Auto switch**

<b>Nil</b>	Without switch
<b>1</b>	NPN, A contact 1pc.
<b>2</b>	NPN, B contact 2pcs.
<b>3</b>	NPN, A contact 1pc., B contact 2pcs.
<b>4</b>	PNP, A contact 1pc.
<b>5</b>	PNP, B contact 2pcs.
<b>6</b>	PNP, A contact 1pc., B contact 2pcs.

**Driver type**

<b>Nil</b>	Without driver
<b>A1</b>	Pulse input type (Incremental encoder) 100 V
<b>A2</b>	Pulse input type (Incremental encoder) 200 V
<b>B1</b>	Pulse input type (Absolute encoder) 100 V
<b>B2</b>	Pulse input type (Absolute encoder) 200 V

## Specifications

Standard stroke (mm)		200	300	400	500	600	800	1000	1200	1500
Performance	Body weight (kg)	16.0	18.0	20.0	22.0	24.0	28.5	33.0	37.0	43.0
	Operating temperature range (°C)	5 to 40 (No condensation)								
	Work load (kg)	60								
	Maximum speed (mm/s) <small>Note</small>	1000							700	500
	Positioning repeatability (mm)	±0.05								
Main parts	Motor	AC servo motor (200 W)								
	Encoder	Incremental system/Absolute type								
	Lead screw	Rolled ball screw ∅25 mm, 25 mm lead								
	Guide	High rigidity direct acting guide								
	Motor/Screw connection	With coupling								
Driver	Model	LECS□□-□ ( Refer to page 885 for details.)								

Note) The speed is limited by the transfer load. Refer to the maximum speeds for each transfer load on page 805.

## Allowable Moment (N·m)

### Allowable static moment

Pitching	117
Rolling	137
Yawing	123

**m** : Transfer load (kg)  
**a** : Workpiece acceleration (mm/s<sup>2</sup>)  
**Me** : Dynamic moment  
**L** : Overhang to workpiece center of gravity (mm)

### Allowable dynamic moment

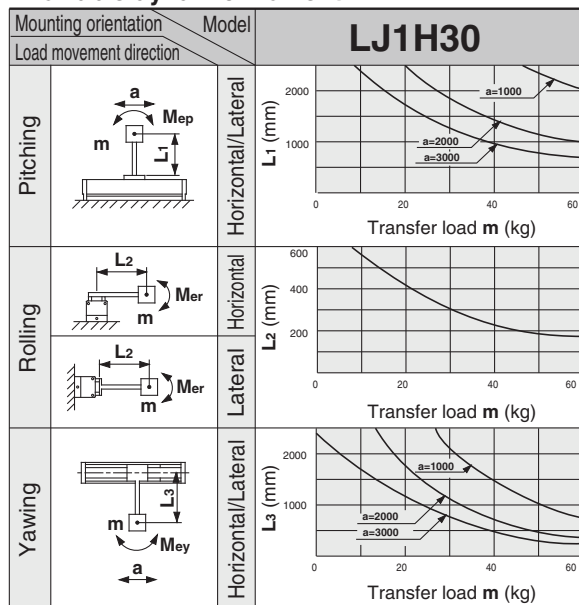

Refer to page 833 for deflection data.

## Investigation of the regeneration option

Depending on the conditions (speed, addition-subtraction speed, down time, load, etc.), the regeneration option may be required. The results of consideration in each case of maximum load or half load for the product specification are below. Please consult SMC when considering the necessity of the regeneration option.

### Maximum load

Driver type	Regeneration option model
<b>A1</b>	<b>LEC-MR-RB-032</b>
<b>A2</b>	Not required.
<b>B1</b>	<b>LEC-MR-RB-032</b>
<b>B2</b>	Not required.

### Half load

Driver type	Regeneration option model
<b>A1</b>	Not required.
<b>A2</b>	Not required.
<b>B1</b>	Not required.
<b>B2</b>	Not required.

## Dimensions/LJ1H30□ND

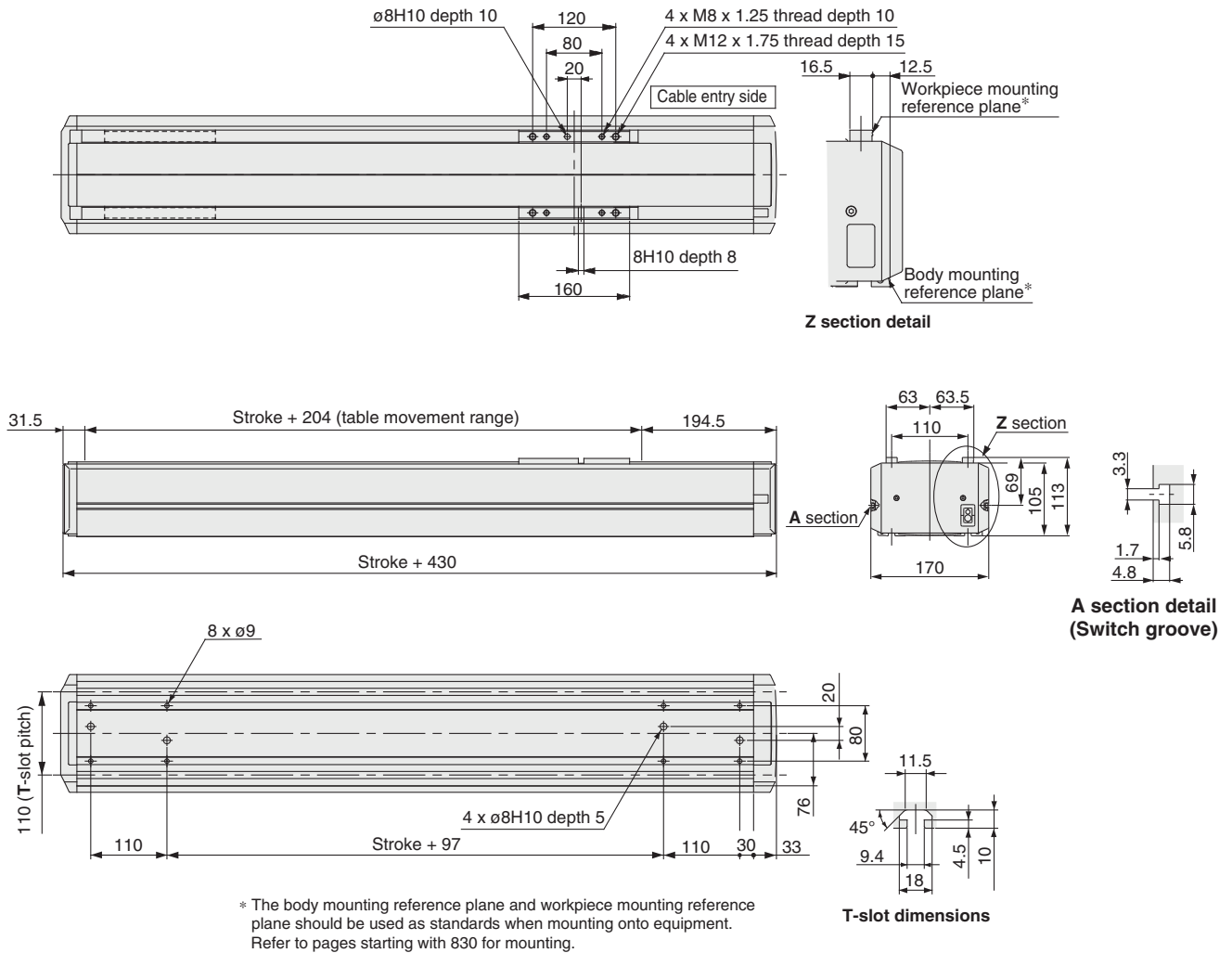

LJ1

LG1

LTF

LECS□

LXF

LXP

LXS

LC6□

LZ□

LC3F2

D-□

E-MY

## Positioning Time Guide

		Positioning time (sec.)				
		1	10	100	750	1500
Speed (mm/s)	10	1.1	2.0	11.0	76.0	151.0
	100	1.1	1.2	2.1	8.6	16.1
	500	1.1	1.2	1.4	2.7	4.2
	1000	1.1	1.2	1.4	2.1	2.9

\* Values will vary slightly depending on the operating conditions.

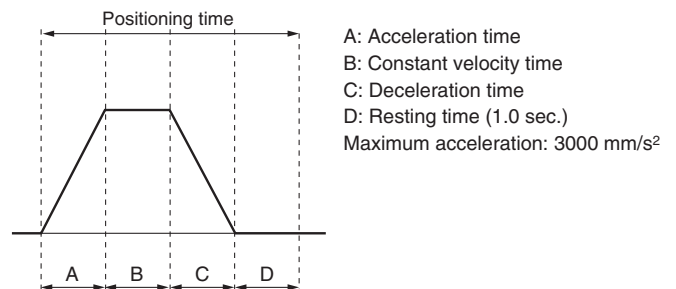

## Maximum Speeds for Each Transfer Load

Unit (mm/s)

Model	Transfer load (kg)					
	10	20	30	40	50	60
LJ1H30□ND-200 to 1000-□	1000	1000	1000	1000	900	800
LJ1H30□ND-1200-□	700	700	700	700	700	700
LJ1H30□ND-1500-□	500	500	500	500	500	500
LJ1H30□ND-200 to 1000-□	1000	900	800	700	650	600
LJ1H30□ND-1200-□	700	700	700	700	650	600
LJ1H30□ND-1500-□	500	500	500	500	500	500

\* Consult SMC if outside of the above conditions.

# Standard Motor Vertical Mount Series **LJ1H10**

Motor Output  
**100 W**

High Rigidity  
Direct Acting  
Guide

Ground Ball Screw  
**∅12 mm/8 mm lead**



## How to Order

**LJ1H10 S2 PH - 300 K - F R 2 A1** - [ ] - [ ]

**Motor type**

<b>S2</b>	AC servo motor (Incremental encoder) 100 W
<b>S6</b>	AC servo motor (Absolute encoder) 100 W

**Stroke (mm)**  
Refer to the standard stroke.

**Cable entry direction**

<b>F</b>	Axial
<b>R</b>	Right
<b>L</b>	Left
<b>T</b>	Top
<b>B</b>	Bottom

**Cable type**

<b>S</b>	Standard cable
<b>R</b>	Robotic cable (flexible cable)

**Cable length**

<b>2</b>	2 m
<b>5</b>	5 m
<b>A</b>	10 m

**IO connector**

<b>Nil</b>	None
<b>H</b>	With IO connector

**Auto switch**

Nil	Without switch
<b>1</b>	NPN, A contact 1pc.
<b>2</b>	NPN, B contact 2pcs.
<b>3</b>	NPN, A contact 1pc., B contact 2pcs.
<b>4</b>	PNP, A contact 1pc.
<b>5</b>	PNP, B contact 2pcs.
<b>6</b>	PNP, A contact 1pc., B contact 2pcs.

**Driver type**

Nil	Without driver
<b>A1</b>	Pulse input type (Incremental encoder) 100 V
<b>A2</b>	Pulse input type (Incremental encoder) 200 V
<b>B1</b>	Pulse input type (Absolute encoder) 100 V
<b>B2</b>	Pulse input type (Absolute encoder) 200 V

**Cable entry direction**

## Specifications

Standard stroke (mm)		100	200	300	400	500
Performance	Body weight (kg)	5.5	6.3	7.1	7.8	8.6
	Operating temperature range (°C)	5 to 40 (No condensation)				
	Work load (kg)	10				
	Maximum speed (mm/s)	400				
	Positioning repeatability (mm)	±0.02				
Main parts	Motor	AC servo motor (100 W) with lock				
	Encoder	Incremental system/Absolute type				
	Lead screw	Ground ball screw ∅12 mm, 8 mm lead				
	Guide	High rigidity direct acting guide				
	Motor/Screw connection	With coupling				
Driver	Model	LECS□□□□ (Refer to page 885 for details.)				

## Allowable Moment (N·m)

### Allowable static moment

Pitching	10.2
Yawing	10.2

**m** : Transfer load (kg)  
**a** : Workpiece acceleration (mm/s<sup>2</sup>)  
**Me** : Dynamic moment  
**L** : Overhang to workpiece center of gravity (mm)

### Allowable dynamic moment

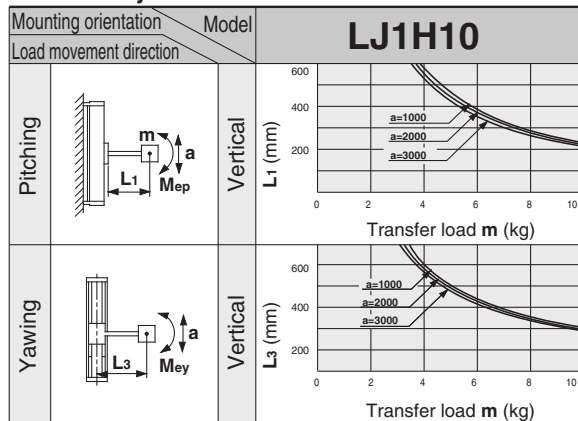

Refer to page 833 for deflection data.

Note) When using this product, the regeneration option may be required.

## Investigation of the regeneration option

Depending on the conditions (speed, addition-subtraction speed, down time, load, etc.), the regeneration option may be required.

The results of consideration in each case of maximum load or half load for the product specification are below.

Please consult SMC when considering the necessity of the regeneration option.

### Maximum load

Driver type	Regeneration option model
<b>A1</b>	<b>LEC-MR-RB-032</b>
<b>A2</b>	<b>LEC-MR-RB-032</b>
<b>B1</b>	<b>LEC-MR-RB-032</b>
<b>B2</b>	<b>LEC-MR-RB-032</b>

### Half load

Driver type	Regeneration option model
<b>A1</b>	<b>LEC-MR-RB-032</b>
<b>A2</b>	<b>LEC-MR-RB-032</b>
<b>B1</b>	<b>LEC-MR-RB-032</b>
<b>B2</b>	<b>LEC-MR-RB-032</b>

## Dimensions/LJ1H10□PH

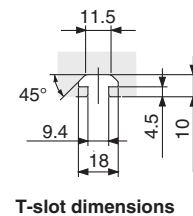
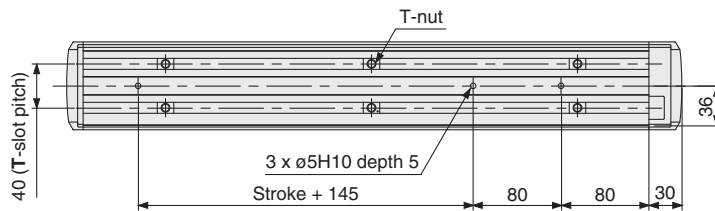
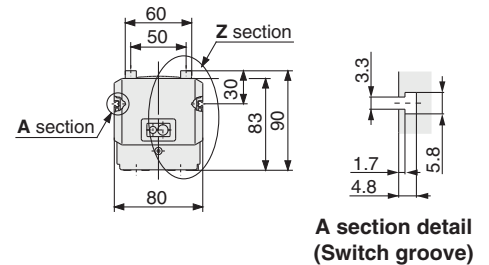
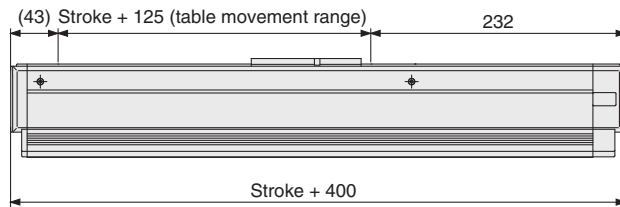
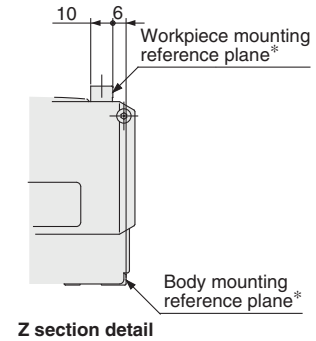
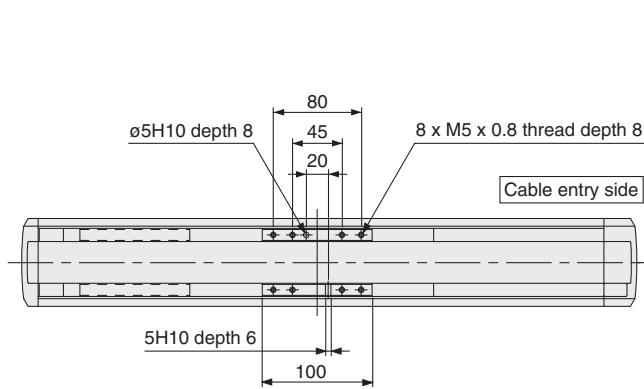

\* The body mounting reference plane and workpiece mounting reference plane should be used as standards when mounting onto equipment. Refer to pages starting with 830 for mounting.

## Positioning Time Guide

		Positioning time (sec.)				
		1	10	100	250	500
Speed (mm/s)	10	0.4	1.3	10.3	25.3	50.3
	100	0.4	0.5	1.4	2.9	5.4
	200	0.4	0.5	0.9	1.7	2.9
	400	0.4	0.5	0.7	1.1	1.7

\* Values will vary slightly depending on the operating conditions.

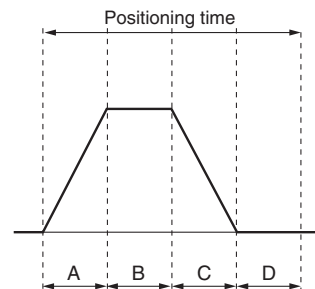

A: Acceleration time  
 B: Constant velocity time  
 C: Deceleration time  
 D: Resting time (0.3 sec.)  
 Maximum acceleration: 3000 mm/s<sup>2</sup>

LJ1

LG1

LTF

LECS□

LXF

LXP

LXS

LC6□

LZ□

LC3F2

D-□

E-MY

# Standard Motor Vertical Mount Series LJ1H10

Motor Output  
**100 W**

High Rigidity  
Direct Acting  
Guide

Ground Ball Screw  
**∅12 mm/12 mm lead**



## How to Order

**LJ1H10 S2 PB - 300 K - F R 2 A1**

**Motor type**

<b>S2</b>	AC servo motor (Incremental encoder) 100 W
<b>S6</b>	AC servo motor (Absolute encoder) 100 W

**Stroke (mm)**  
Refer to the standard stroke.

**Cable entry direction**

<b>F</b>	Axial
<b>R</b>	Right
<b>L</b>	Left
<b>T</b>	Top
<b>B</b>	Bottom

**Cable type**

<b>S</b>	Standard cable
<b>R</b>	Robotic cable (flexible cable)

**Cable length**

<b>2</b>	2 m
<b>5</b>	5 m
<b>A</b>	10 m

**IO connector**

<b>Nil</b>	None
<b>H</b>	With IO connector

**Auto switch**

<b>Nil</b>	Without switch
<b>1</b>	NPN, A contact 1pc.
<b>2</b>	NPN, B contact 2pcs.
<b>3</b>	NPN, A contact 1pc., B contact 2pcs.
<b>4</b>	PNP, A contact 1pc.
<b>5</b>	PNP, B contact 2pcs.
<b>6</b>	PNP, A contact 1pc., B contact 2pcs.

**Driver type**

<b>Nil</b>	Without driver
<b>A1</b>	Pulse input type (Incremental encoder) 100 V
<b>A2</b>	Pulse input type (Incremental encoder) 200 V
<b>B1</b>	Pulse input type (Absolute encoder) 100 V
<b>B2</b>	Pulse input type (Absolute encoder) 200 V

**Cable entry direction**

## Specifications

Standard stroke (mm)		100	200	300	400	500
Performance	Body weight (kg)	5.5	6.3	7.1	7.8	8.6
	Operating temperature range (°C)	5 to 40 (No condensation)				
	Work load (kg)	5				
	Maximum speed (mm/s)	600				
	Positioning repeatability (mm)	±0.02				
Main parts	Motor	AC servo motor (100 W) with lock				
	Encoder	Incremental system/Absolute type				
	Lead screw	Ground ball screw ∅12 mm, 12 mm lead				
	Guide	High rigidity direct acting guide				
	Motor/Screw connection	With coupling				
Driver	Model	LECS□□-□ (Refer to page 885 for details.)				

## Allowable Moment (N·m)

### Allowable static moment

Pitching	10.2
Yawing	10.2

**m** : Transfer load (kg)  
**a** : Workpiece acceleration (mm/s<sup>2</sup>)  
**Me** : Dynamic moment  
**L** : Overhang to workpiece center of gravity (mm)

### Allowable dynamic moment

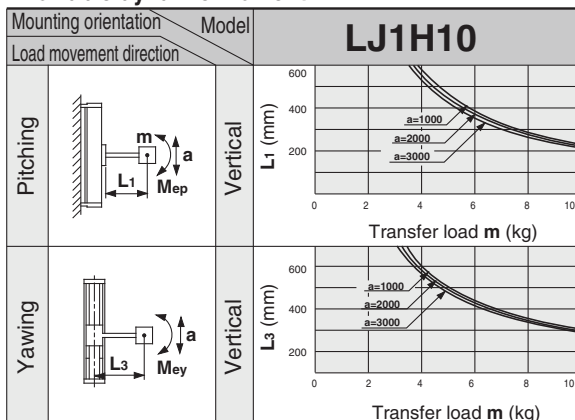

Refer to page 833 for deflection data.

Note) When using this product, the regeneration option may be required.

### Investigation of the regeneration option

Depending on the conditions (speed, addition-subtraction speed, down time, load, etc.), the regeneration option may be required.

The results of consideration in each case of maximum load or half load for the product specification are below.

Please consult SMC when considering the necessity of the regeneration option.

#### Maximum load

Driver type	Regeneration option model
<b>A1</b>	<b>LEC-MR-RB-032</b>
<b>A2</b>	<b>LEC-MR-RB-032</b>
<b>B1</b>	<b>LEC-MR-RB-032</b>
<b>B2</b>	<b>LEC-MR-RB-032</b>

#### Half load

Driver type	Regeneration option model
<b>A1</b>	Not required.
<b>A2</b>	Not required.
<b>B1</b>	Not required.
<b>B2</b>	Not required.

## Dimensions/LJ1H10□PB

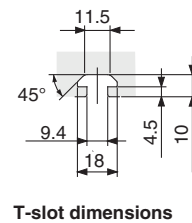
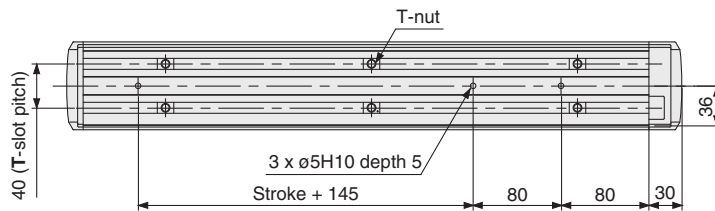
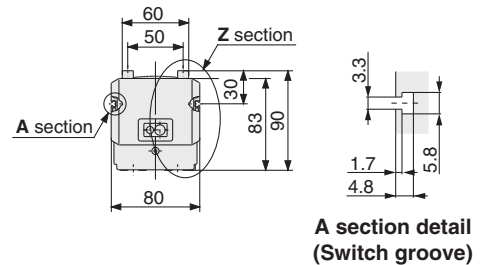
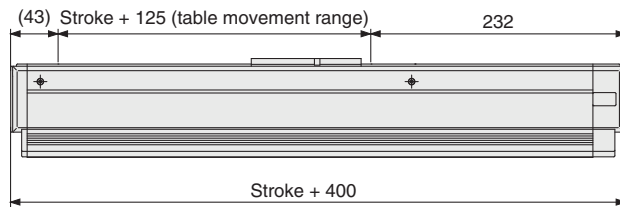
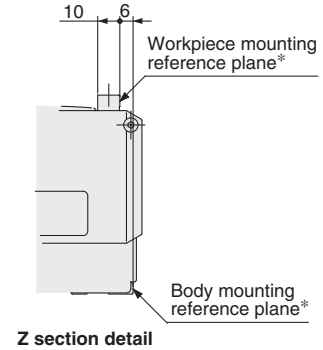
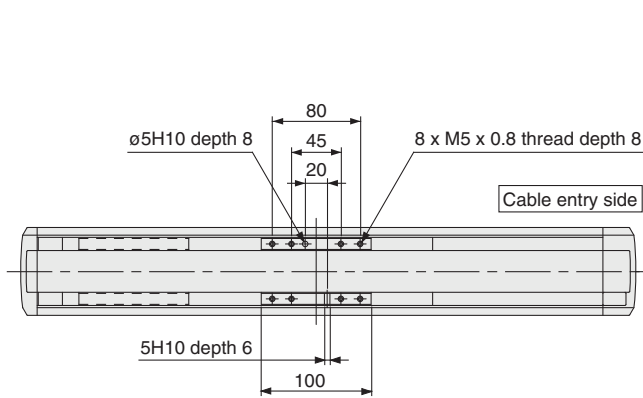

\* The body mounting reference plane and workpiece mounting reference plane should be used as standards when mounting onto equipment. Refer to pages starting with 830 for mounting.

## Positioning Time Guide

		Positioning time (sec.)				
		1	10	100	250	500
Speed (mm/s)	10	0.4	1.3	10.3	25.3	50.3
	100	0.4	0.5	1.4	2.9	5.4
	300	0.4	0.5	0.8	1.3	2.1
	600	0.4	0.5	0.7	1.0	1.4

\* Values will vary slightly depending on the operating conditions.

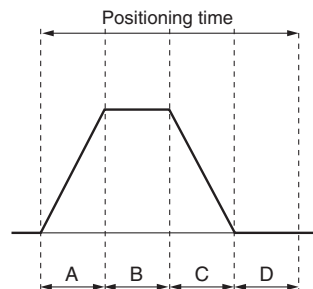

A: Acceleration time  
 B: Constant velocity time  
 C: Deceleration time  
 D: Resting time (0.3 sec.)  
 Maximum acceleration: 3000 mm/s<sup>2</sup>

**LJ1**

**LG1**

**LTF**

**LECS** □

**LXF**

**LXP**

**LXS**

**LC6** □

**LZ** □

**LC3F2**

**D-** □

**E-MY**

# Standard Motor Vertical Mount Series **LJ1H10**

Motor Output  
**100 W**

High Rigidity  
Direct Acting  
Guide

Rolled Ball Screw  
**∅12 mm/8 mm lead**



## How to Order

**LJ1H10 S2 NH - 300 K - F R 2 A1**

**Motor type**

<b>S2</b>	AC servo motor (Incremental encoder) 100 W
<b>S6</b>	AC servo motor (Absolute encoder) 100 W

**Stroke (mm)**  
Refer to the standard stroke.

**Cable type**

<b>S</b>	Standard cable
<b>R</b>	Robotic cable (flexible cable)

**Cable length**

<b>2</b>	2 m
<b>5</b>	5 m
<b>A</b>	10 m

**Cable entry direction**

<b>F</b>	Axial
<b>R</b>	Right
<b>L</b>	Left
<b>T</b>	Top
<b>B</b>	Bottom

**IO connector**

<b>Nil</b>	None
<b>H</b>	With IO connector

**Driver type**

<b>Nil</b>	Without driver
<b>A1</b>	Pulse input type (Incremental encoder) 100 V
<b>A2</b>	Pulse input type (Incremental encoder) 200 V
<b>B1</b>	Pulse input type (Absolute encoder) 100 V
<b>B2</b>	Pulse input type (Absolute encoder) 200 V

**Auto switch**

<b>Nil</b>	Without switch
<b>1</b>	NPN, A contact 1pc.
<b>2</b>	NPN, B contact 2pcs.
<b>3</b>	NPN, A contact 1pc., B contact 2pcs.
<b>4</b>	PNP, A contact 1pc.
<b>5</b>	PNP, B contact 2pcs.
<b>6</b>	PNP, A contact 1pc., B contact 2pcs.

**Cable entry direction**

## Specifications

		100	200	300	400	500
<b>Performance</b>	<b>Standard stroke (mm)</b>	100	200	300	400	500
	<b>Body weight (kg)</b>	5.5	6.3	7.1	7.8	8.6
	<b>Operating temperature range (°C)</b>	5 to 40 (No condensation)				
	<b>Work load (kg)</b>	10				
	<b>Maximum speed (mm/s)</b>	400				
<b>Main parts</b>	<b>Positioning repeatability (mm)</b>	±0.05				
	<b>Motor</b>	AC servo motor (100 W) with lock				
	<b>Encoder</b>	Incremental system/Absolute type				
	<b>Lead screw</b>	Rolled ball screw ∅12 mm, 8 mm lead				
	<b>Guide</b>	High rigidity direct acting guide				
	<b>Motor/Screw connection</b>	With coupling				
<b>Driver</b>	<b>Model</b>	LECS□□□ (Refer to page 885 for details.)				

## Allowable Moment (N·m)

### Allowable static moment

Pitching	10.2
Yawing	10.2

**m** : Transfer load (kg)  
**a** : Workpiece acceleration (mm/s<sup>2</sup>)  
**Me** : Dynamic moment  
**L** : Overhang to workpiece center of gravity (mm)

### Allowable dynamic moment

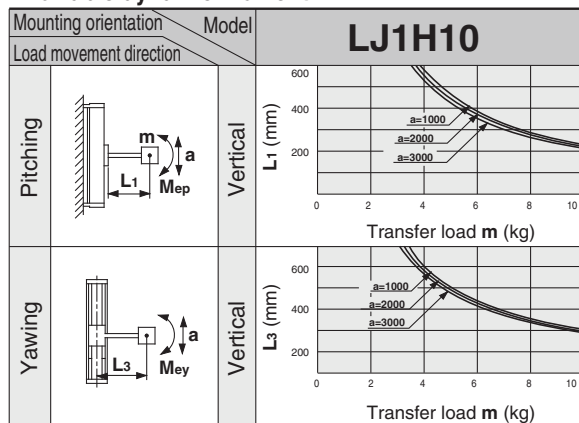

Refer to page 833 for deflection data.

Note) When using this product, the regeneration option may be required.

## Investigation of the regeneration option

Depending on the conditions (speed, addition-subtraction speed, down time, load, etc.), the regeneration option may be required.

The results of consideration in each case of maximum load or half load for the product specification are below.

Please consult SMC when considering the necessity of the regeneration option.

### Maximum load

Driver type	Regeneration option model
<b>A1</b>	<b>LEC-MR-RB-032</b>
<b>A2</b>	<b>LEC-MR-RB-032</b>
<b>B1</b>	<b>LEC-MR-RB-032</b>
<b>B2</b>	<b>LEC-MR-RB-032</b>

### Half load

Driver type	Regeneration option model
<b>A1</b>	<b>LEC-MR-RB-032</b>
<b>A2</b>	<b>LEC-MR-RB-032</b>
<b>B1</b>	<b>LEC-MR-RB-032</b>
<b>B2</b>	<b>LEC-MR-RB-032</b>



**Dimensions/LJ1H10□NH**

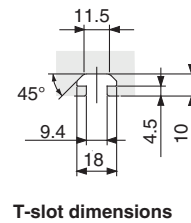
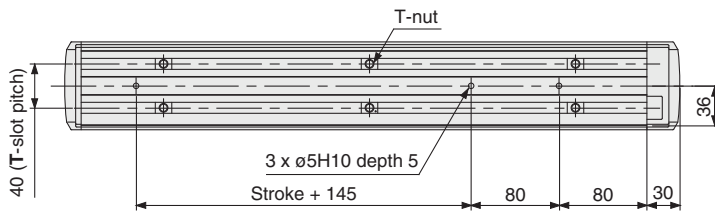
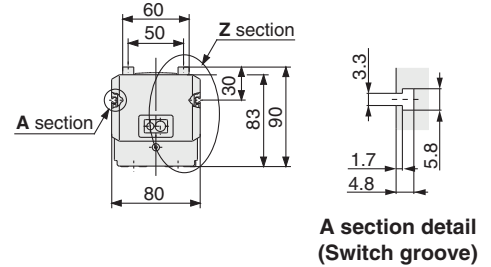
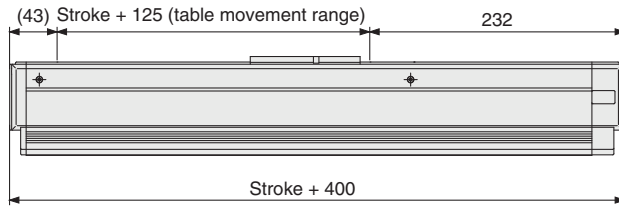
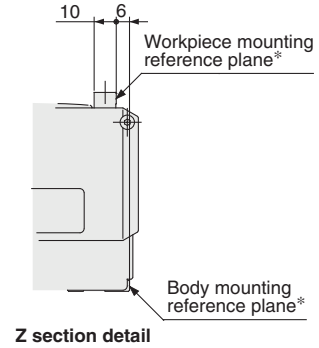
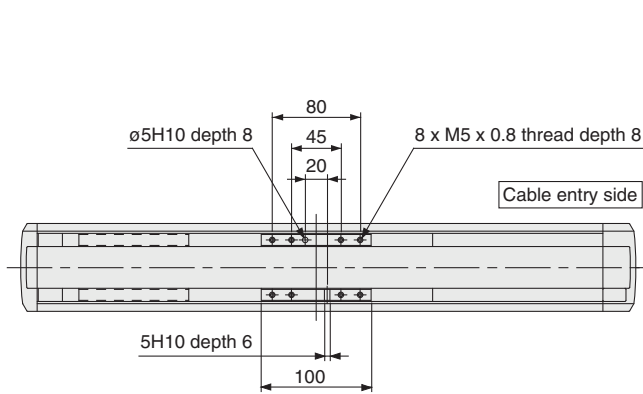

\* The body mounting reference plane and workpiece mounting reference plane should be used as standards when mounting onto equipment. Refer to pages starting with 830 for mounting.

**Positioning Time Guide**

		Positioning time (sec.)				
		1	10	100	250	500
Speed (mm/s)	10	0.4	1.3	10.3	25.3	50.3
	100	0.4	0.5	1.4	2.9	5.4
	200	0.4	0.5	0.9	1.7	2.9
	400	0.4	0.5	0.7	1.1	1.7

\* Values will vary slightly depending on the operating conditions.

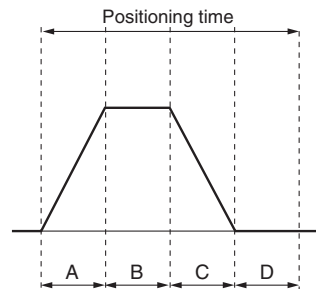

A: Acceleration time  
 B: Constant velocity time  
 C: Deceleration time  
 D: Resting time (0.3 sec.)  
 Maximum acceleration: 3000 mm/s<sup>2</sup>

- LJ1**
- LG1**
- LTF**
- LECS□**
- LXF**
- LXP**
- LXS**
- LC6□**
- LZ□**
- LC3F2**
- D-□**
- E-MY**

# Standard Motor Vertical Mount Series LJ1H10

Motor Output  
**100 W**

High Rigidity  
Direct Acting  
Guide

Rolled Ball Screw  
**∅12 mm/12 mm lead**



## How to Order

**LJ1H10 S2 NB - 300 K - F R 2 A1**

**Motor type**

<b>S2</b>	AC servo motor (Incremental encoder) 100 W
<b>S6</b>	AC servo motor (Absolute encoder) 100 W

**Stroke (mm)**  
Refer to the standard stroke.

**Cable type**

<b>S</b>	Standard cable
<b>R</b>	Robotic cable (flexible cable)

**Cable length**

<b>2</b>	2 m
<b>5</b>	5 m
<b>A</b>	10 m

**Cable entry direction**

<b>F</b>	Axial
<b>R</b>	Right
<b>L</b>	Left
<b>T</b>	Top
<b>B</b>	Bottom

**IO connector**

<b>Nil</b>	None
<b>H</b>	With IO connector

**Driver type**

<b>Nil</b>	Without driver
<b>A1</b>	Pulse input type (Incremental encoder) 100 V
<b>A2</b>	Pulse input type (Incremental encoder) 200 V
<b>B1</b>	Pulse input type (Absolute encoder) 100 V
<b>B2</b>	Pulse input type (Absolute encoder) 200 V

**Auto switch**

<b>Nil</b>	Without switch
<b>1</b>	NPN, A contact 1pc.
<b>2</b>	NPN, B contact 2pcs.
<b>3</b>	NPN, A contact 1pc., B contact 2pcs.
<b>4</b>	PNP, A contact 1pc.
<b>5</b>	PNP, B contact 2pcs.
<b>6</b>	PNP, A contact 1pc., B contact 2pcs.

**Cable entry direction**

## Specifications

Standard stroke (mm)		100	200	300	400	500
Performance	Body weight (kg)	5.5	6.3	7.1	7.8	8.6
	Operating temperature range (°C)	5 to 40 (No condensation)				
	Work load (kg)	5				
	Maximum speed (mm/s)	600				
	Positioning repeatability (mm)	±0.05				
Main parts	Motor	AC servo motor (100 W) with lock				
	Encoder	Incremental system/Absolute type				
	Lead screw	Rolled ball screw ∅12 mm, 12 mm lead				
	Guide	High rigidity direct acting guide				
	Motor/Screw connection	With coupling				
Driver	Model	LECS□□-□ (Refer to page 885 for details.)				

## Allowable Moment (N·m)

### Allowable static moment

Pitching	10.2
Yawing	10.2

**m** : Transfer load (kg)  
**a** : Workpiece acceleration (mm/s<sup>2</sup>)  
**Me** : Dynamic moment  
**L** : Overhang to workpiece center of gravity (mm)

### Allowable dynamic moment

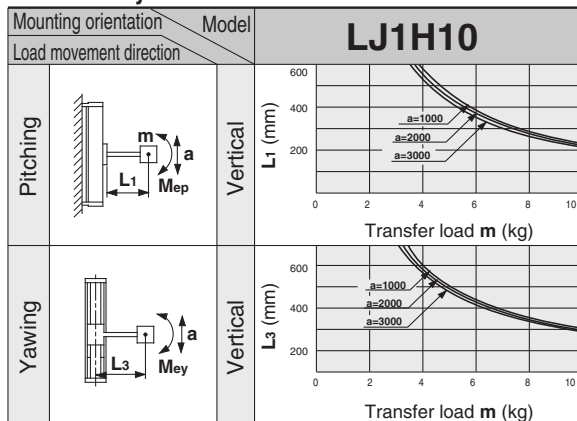

Refer to page 833 for deflection data.

Note) When using this product, the regeneration option may be required.

## Investigation of the regeneration option

Depending on the conditions (speed, addition-subtraction speed, down time, load, etc.), the regeneration option may be required.

The results of consideration in each case of maximum load or half load for the product specification are below.

Please consult SMC when considering the necessity of the regeneration option.

### Maximum load

Driver type	Regeneration option model
<b>A1</b>	<b>LEC-MR-RB-032</b>
<b>A2</b>	<b>LEC-MR-RB-032</b>
<b>B1</b>	<b>LEC-MR-RB-032</b>
<b>B2</b>	<b>LEC-MR-RB-032</b>

### Half load

Driver type	Regeneration option model
<b>A1</b>	Not required.
<b>A2</b>	Not required.
<b>B1</b>	Not required.
<b>B2</b>	Not required.

## Dimensions/LJ1H10□NB

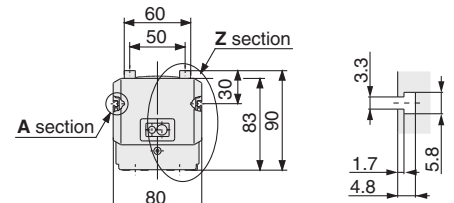
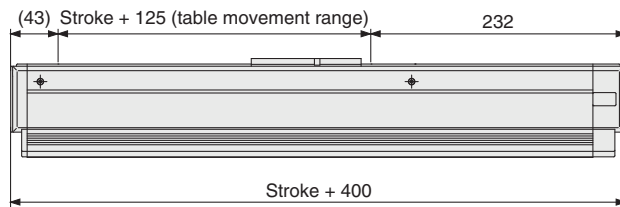
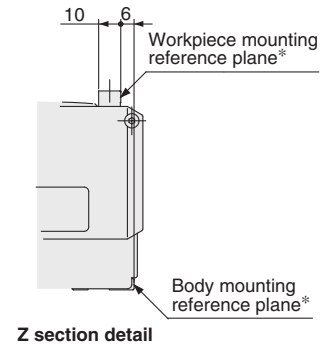
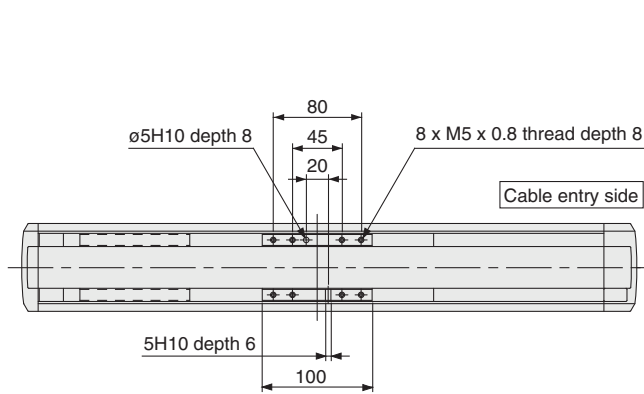

**A section detail (Switch groove)**

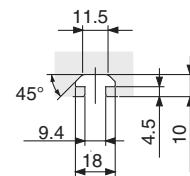
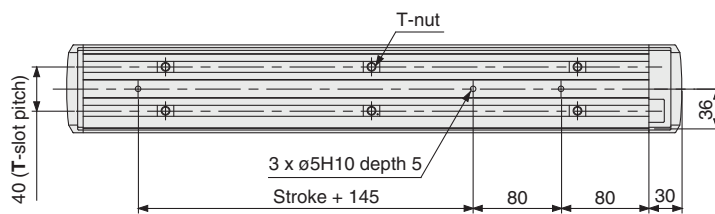

**T-slot dimensions**

\* The body mounting reference plane and workpiece mounting reference plane should be used as standards when mounting onto equipment. Refer to pages starting with 830 for mounting.

## Positioning Time Guide

		Positioning time (sec.)				
		1	10	100	250	500
Speed (mm/s)	10	0.4	1.3	10.3	25.3	50.3
	100	0.4	0.5	1.4	2.9	5.4
	300	0.4	0.5	0.8	1.3	2.1
	600	0.4	0.5	0.7	1.0	1.4

\* Values will vary slightly depending on the operating conditions.

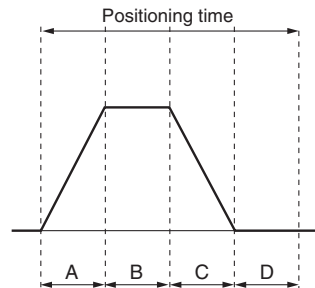

A: Acceleration time  
 B: Constant velocity time  
 C: Deceleration time  
 D: Resting time (0.3 sec.)  
 Maximum acceleration: 3000 mm/s<sup>2</sup>

**LJ1**

**LG1**

**LTF**

**LECS□**

**LXF**

**LXP**

**LXS**

**LC6□**

**LZ□**

**LC3F2**

**D-□**

**E-MY**

# Standard Motor Vertical Mount Series **LJ1H20**

Motor Output  
**100 W**

High Rigidity  
Direct Acting  
Guide

Ground Ball Screw  
**∅15 mm/5 mm lead**



## How to Order

**LJ1H20** **S2** **PF** - **300** **K** - **F** **R** **2** **A1** - -

**Motor type**

<b>S2</b>	AC servo motor (Incremental encoder) 100 W
<b>S6</b>	AC servo motor (Absolute encoder) 100 W

**Stroke (mm)**  
Refer to the standard stroke.

**Cable entry direction**

<b>F</b>	Axial
<b>R</b>	Right
<b>L</b>	Left
<b>T</b>	Top
<b>B</b>	Bottom

**Cable type**

<b>S</b>	Standard cable
<b>R</b>	Robotic cable (flexible cable)

**Cable length**

<b>2</b>	2 m
<b>5</b>	5 m
<b>A</b>	10 m

**IO connector**

<b>Nil</b>	None
<b>H</b>	With IO connector

**Auto switch**

<b>Nil</b>	Without switch
<b>1</b>	NPN, A contact 1pc.
<b>2</b>	NPN, B contact 2pcs.
<b>3</b>	NPN, A contact 1pc., B contact 2pcs.
<b>4</b>	PNP, A contact 1pc.
<b>5</b>	PNP, B contact 2pcs.
<b>6</b>	PNP, A contact 1pc., B contact 2pcs.

**Driver type**

<b>Nil</b>	Without driver
<b>A1</b>	Pulse input type (Incremental encoder) 100 V
<b>A2</b>	Pulse input type (Incremental encoder) 200 V
<b>B1</b>	Pulse input type (Absolute encoder) 100 V
<b>B2</b>	Pulse input type (Absolute encoder) 200 V

**Cable entry direction**

## Specifications

Standard stroke (mm)		100	200	300	400	500	600
Performance	Body weight (kg)	8.0	9.2	10.4	11.5	12.9	14.0
	Operating temperature range (°C)	5 to 40 (No condensation)					
	Work load (kg)	15					
	Maximum speed (mm/s)	250					
	Positioning repeatability (mm)	±0.02					
Main parts	Motor	AC servo motor (100 W) with lock					
	Encoder	Incremental system/Absolute type					
	Lead screw	Ground ball screw ∅15 mm, 5 mm lead					
	Guide	High rigidity direct acting guide					
	Motor/Screw connection	With coupling					
Driver	Model	LECS□□-□ (Refer to page 885 for details.)					

## Allowable Moment (N·m)

### Allowable static moment

Pitching	71
Yawing	75

**m** : Transfer load (kg)  
**a** : Workpiece acceleration (mm/s<sup>2</sup>)  
**Me** : Dynamic moment  
**L** : Overhang to workpiece center of gravity (mm)

### Allowable dynamic moment

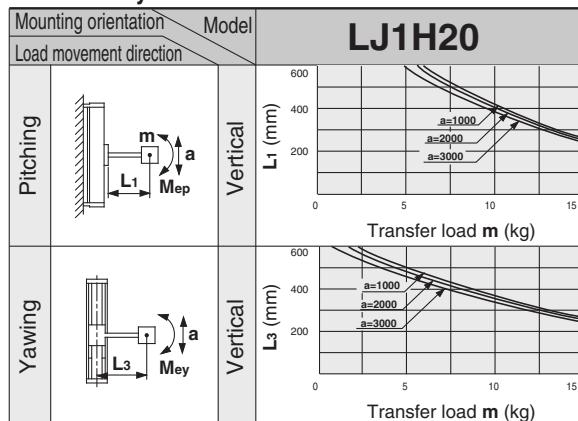

Refer to page 833 for deflection data.

Note) When using this product, the regeneration option may be required.

## Investigation of the regeneration option

Depending on the conditions (speed, addition-subtraction speed, down time, load, etc.), the regeneration option may be required.

The results of consideration in each case of maximum load or half load for the product specification are below.

Please consult SMC when considering the necessity of the regeneration option.

### Maximum load

Driver type	Regeneration option model
<b>A1</b>	<b>LEC-MR-RB-032</b>
<b>A2</b>	<b>LEC-MR-RB-032</b>
<b>B1</b>	<b>LEC-MR-RB-032</b>
<b>B2</b>	<b>LEC-MR-RB-032</b>

### Half load

Driver type	Regeneration option model
<b>A1</b>	<b>LEC-MR-RB-032</b>
<b>A2</b>	<b>LEC-MR-RB-032</b>
<b>B1</b>	<b>LEC-MR-RB-032</b>
<b>B2</b>	<b>LEC-MR-RB-032</b>

## Dimensions/LJ1H20□PF

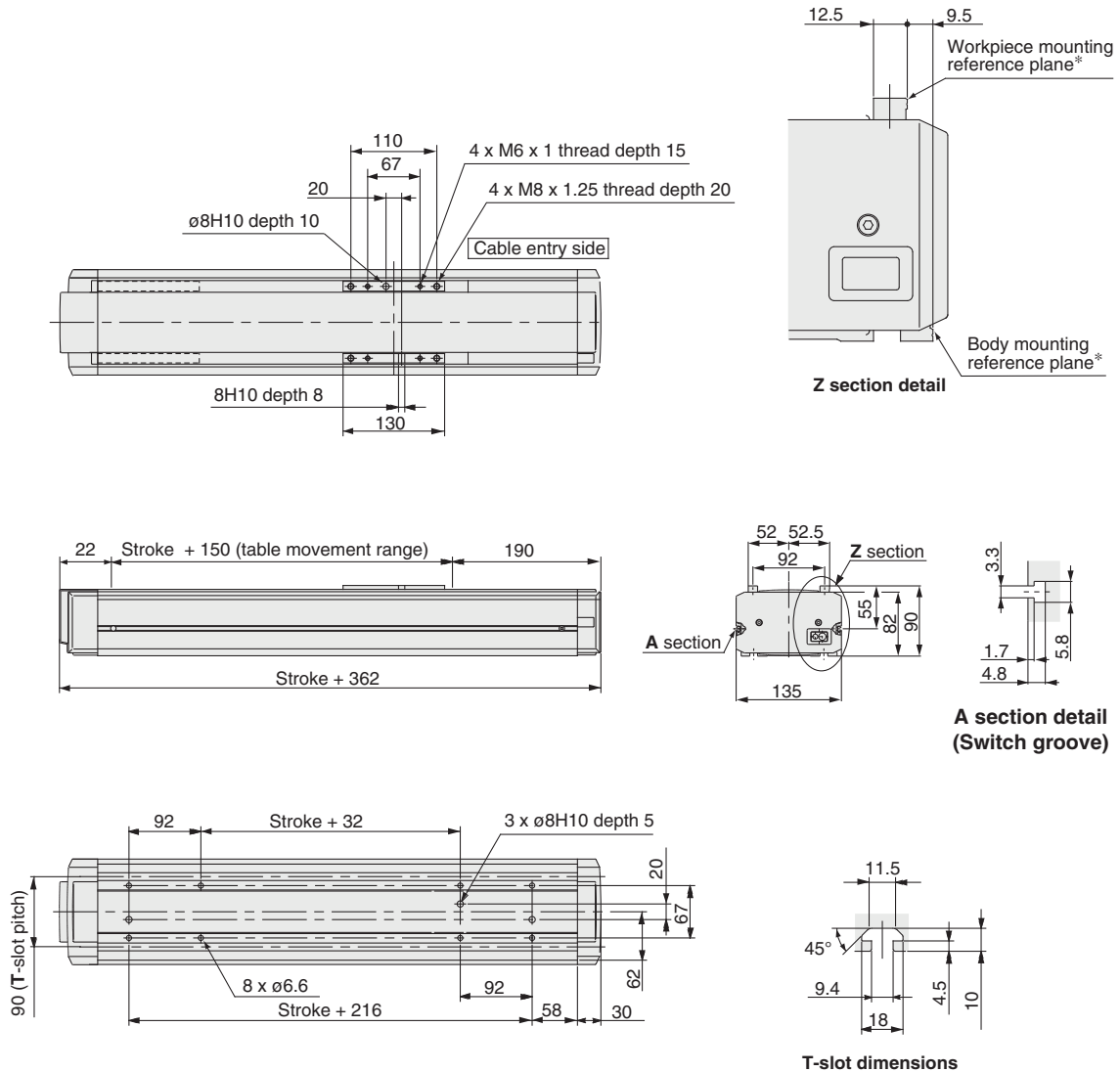

\* The body mounting reference plane and workpiece mounting reference plane should be used as standards when mounting onto equipment. Refer to pages starting with 830 for mounting.

## Positioning Time Guide

		Positioning time (sec.)				
		1	10	100	300	600
Speed (mm/s)	10	0.5	1.4	10.4	30.4	60.4
	100	0.5	0.6	1.5	3.5	6.5
	125	0.5	0.6	1.3	2.9	5.3
	250	0.5	0.6	0.9	1.7	2.9

\* Values will vary slightly depending on the operating conditions.

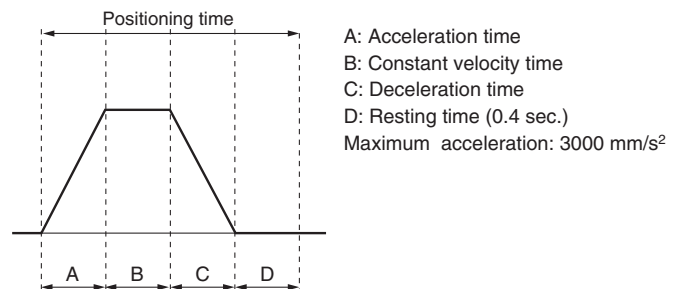

LJ1

LG1

LTF

LECS□

LXF

LXP

LXS

LC6□

LZ□

LC3F2

D-□

E-MY

# Standard Motor Vertical Mount

Motor Output  
**100 W**

High Rigidity  
Direct Acting  
Guide

Ground Ball Screw  
**∅15 mm/10 mm lead**

# Series LJ1H20



## How to Order

**LJ1H20 S2 PA - 300 K - F R 2 A1** - [ ] - [ ]

**Motor type**

S2	AC servo motor (Incremental encoder) 100 W
S6	AC servo motor (Absolute encoder) 100 W

**Stroke (mm)**  
Refer to the standard stroke.

**Cable entry direction**

F	Axial
R	Right
L	Left
T	Top
B	Bottom

**Cable type**

S	Standard cable
R	Robotic cable (flexible cable)

**Cable length**

2	2 m
5	5 m
A	10 m

**IO connector**

Nil	None
H	With IO connector

**Auto switch**

Nil	Without switch
1	NPN, A contact 1pc.
2	NPN, B contact 2pcs.
3	NPN, A contact 1pc., B contact 2pcs.
4	PNP, A contact 1pc.
5	PNP, B contact 2pcs.
6	PNP, A contact 1pc., B contact 2pcs.

**Driver type**

Nil	Without driver
A1	Pulse input type (Incremental encoder) 100 V
A2	Pulse input type (Incremental encoder) 200 V
B1	Pulse input type (Absolute encoder) 100 V
B2	Pulse input type (Absolute encoder) 200 V

## Specifications

Standard stroke (mm)		100	200	300	400	500	600
Performance	Body weight (kg)	8.0	9.2	10.4	11.5	12.9	14.0
	Operating temperature range (°C)	5 to 40 (No condensation)					
	Work load (kg)	8					
	Maximum speed (mm/s)	500					
	Positioning repeatability (mm)	±0.02					
Main parts	Motor	AC servo motor (100 W) with lock					
	Encoder	Incremental system/Absolute type					
	Lead screw	Ground ball screw ∅15 mm, 10 mm lead					
	Guide	High rigidity direct acting guide					
	Motor/Screw connection	With coupling					
Driver	Model	LECS□□-□ (Refer to page 885 for details.)					

## Allowable Moment (N·m)

### Allowable static moment

Pitching	71
Yawing	75

m : Transfer load (kg)  
a : Workpiece acceleration (mm/s<sup>2</sup>)  
Me : Dynamic moment  
L : Overhang to workpiece center of gravity (mm)

### Allowable dynamic moment

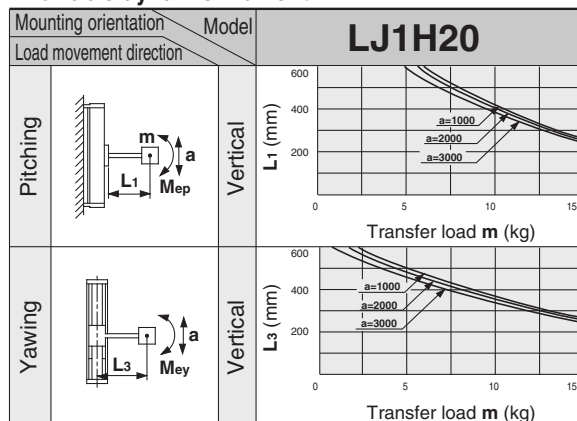

Refer to page 833 for deflection data.

Note) When using this product, the regeneration option may be required.

### Investigation of the regeneration option

Depending on the conditions (speed, addition-subtraction speed, down time, load, etc.), the regeneration option may be required.

The results of consideration in each case of maximum load or half load for the product specification are below.

Please consult SMC when considering the necessity of the regeneration option.

#### Maximum load

Driver type	Regeneration option model
A1	LEC-MR-RB-032
A2	LEC-MR-RB-032
B1	LEC-MR-RB-032
B2	LEC-MR-RB-032

#### Half load

Driver type	Regeneration option model
A1	LEC-MR-RB-032
A2	LEC-MR-RB-032
B1	LEC-MR-RB-032
B2	LEC-MR-RB-032

## Dimensions/LJ1H20□PA

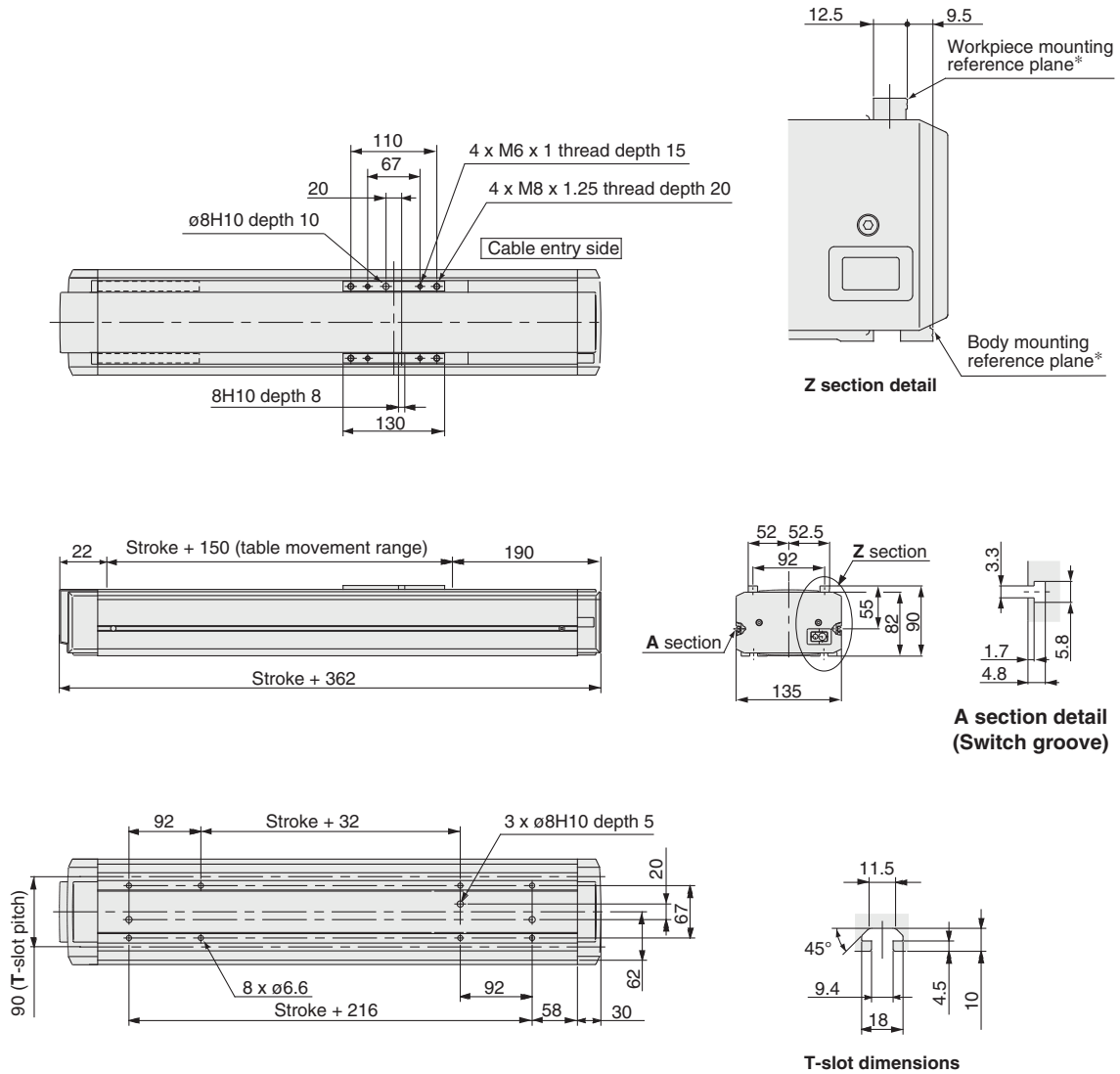

\* The body mounting reference plane and workpiece mounting reference plane should be used as standards when mounting onto equipment. Refer to pages starting with 830 for mounting.

## Positioning Time Guide

		Positioning time (sec.)				
		1	10	100	300	600
Speed (mm/s)	10	0.5	1.4	10.4	30.4	60.4
	100	0.5	0.6	1.5	3.5	6.5
	250	0.5	0.6	0.9	1.7	2.9
	500	0.5	0.6	0.8	1.2	1.8

\* Values will vary slightly depending on the operating conditions.

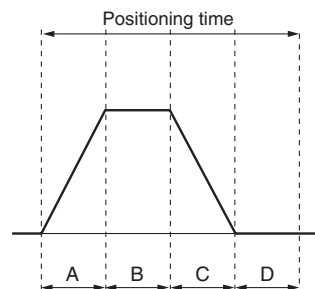

A: Acceleration time  
 B: Constant velocity time  
 C: Deceleration time  
 D: Resting time (0.4 sec.)  
 Maximum acceleration: 3000 mm/s<sup>2</sup>

LJ1

LG1

LTF

LECS□

LXF

LXP

LXS

LC6□

LZ□

LC3F2

D-□

E-MY



# Standard Motor Vertical Mount Series LJ1H20

Motor Output  
**100 W**

High Rigidity  
Direct Acting  
Guide

Rolled Ball Screw  
**∅15 mm/5 mm lead**



## How to Order

**LJ1H20 S2 NF - 300 K - F R 2 A1** - [ ] - [ ]

**Motor type**

<b>S2</b>	AC servo motor (Incremental encoder) 100 W
<b>S6</b>	AC servo motor (Absolute encoder) 100 W

**Stroke (mm)**  
Refer to the standard stroke.

**Cable type**

<b>S</b>	Standard cable
<b>R</b>	Robotic cable (flexible cable)

**Cable length**

<b>2</b>	2 m
<b>5</b>	5 m
<b>A</b>	10 m

**Cable entry direction**

<b>F</b>	Axial
<b>R</b>	Right
<b>L</b>	Left
<b>T</b>	Top
<b>B</b>	Bottom

**IO connector**

<b>Nil</b>	None
<b>H</b>	With IO connector

**Driver type**

<b>Nil</b>	Without driver
<b>A1</b>	Pulse input type (Incremental encoder) 100 V
<b>A2</b>	Pulse input type (Incremental encoder) 200 V
<b>B1</b>	Pulse input type (Absolute encoder) 100 V
<b>B2</b>	Pulse input type (Absolute encoder) 200 V

**Auto switch**

<b>Nil</b>	Without switch
<b>1</b>	NPN, A contact 1pc.
<b>2</b>	NPN, B contact 2pcs.
<b>3</b>	NPN, A contact 1pc., B contact 2pcs.
<b>4</b>	PNP, A contact 1pc.
<b>5</b>	PNP, B contact 2pcs.
<b>6</b>	PNP, A contact 1pc., B contact 2pcs.

**Cable entry direction**

## Specifications

Standard stroke (mm)		100	200	300	400	500	600
Performance	Body weight (kg)	8.0	9.2	10.4	11.5	12.9	14.0
	Operating temperature range (°C)	5 to 40 (No condensation)					
	Work load (kg)	15					
	Maximum speed (mm/s)	250					
	Positioning repeatability (mm)	±0.05					
Main parts	Motor	AC servo motor (100 W) with lock					
	Encoder	Incremental system/Absolute type					
	Lead screw	Rolled ball screw ∅15 mm, 5 mm lead					
	Guide	High rigidity direct acting guide					
	Motor/Screw connection	With coupling					
Driver	Model	LECS□□-□ (Refer to page 885 for details.)					

## Allowable Moment (N·m)

### Allowable static moment

Pitching	71
Yawing	75

**m** : Transfer load (kg)  
**a** : Workpiece acceleration (mm/s<sup>2</sup>)  
**Me** : Dynamic moment  
**L** : Overhang to workpiece center of gravity (mm)

### Allowable dynamic moment

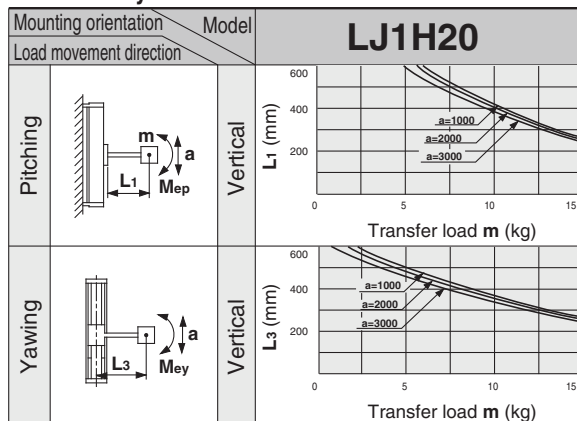

Refer to page 833 for deflection data.

Note) When using this product, the regeneration option may be required.

### Investigation of the regeneration option

Depending on the conditions (speed, addition-subtraction speed, down time, load, etc.), the regeneration option may be required. The results of consideration in each case of maximum load or half load for the product specification are below. Please consult SMC when considering the necessity of the regeneration option.

#### Maximum load

Driver type	Regeneration option model
<b>A1</b>	<b>LEC-MR-RB-032</b>
<b>A2</b>	<b>LEC-MR-RB-032</b>
<b>B1</b>	<b>LEC-MR-RB-032</b>
<b>B2</b>	<b>LEC-MR-RB-032</b>

#### Half load

Driver type	Regeneration option model
<b>A1</b>	<b>LEC-MR-RB-032</b>
<b>A2</b>	<b>LEC-MR-RB-032</b>
<b>B1</b>	<b>LEC-MR-RB-032</b>
<b>B2</b>	<b>LEC-MR-RB-032</b>

## Dimensions/LJ1H20□NF

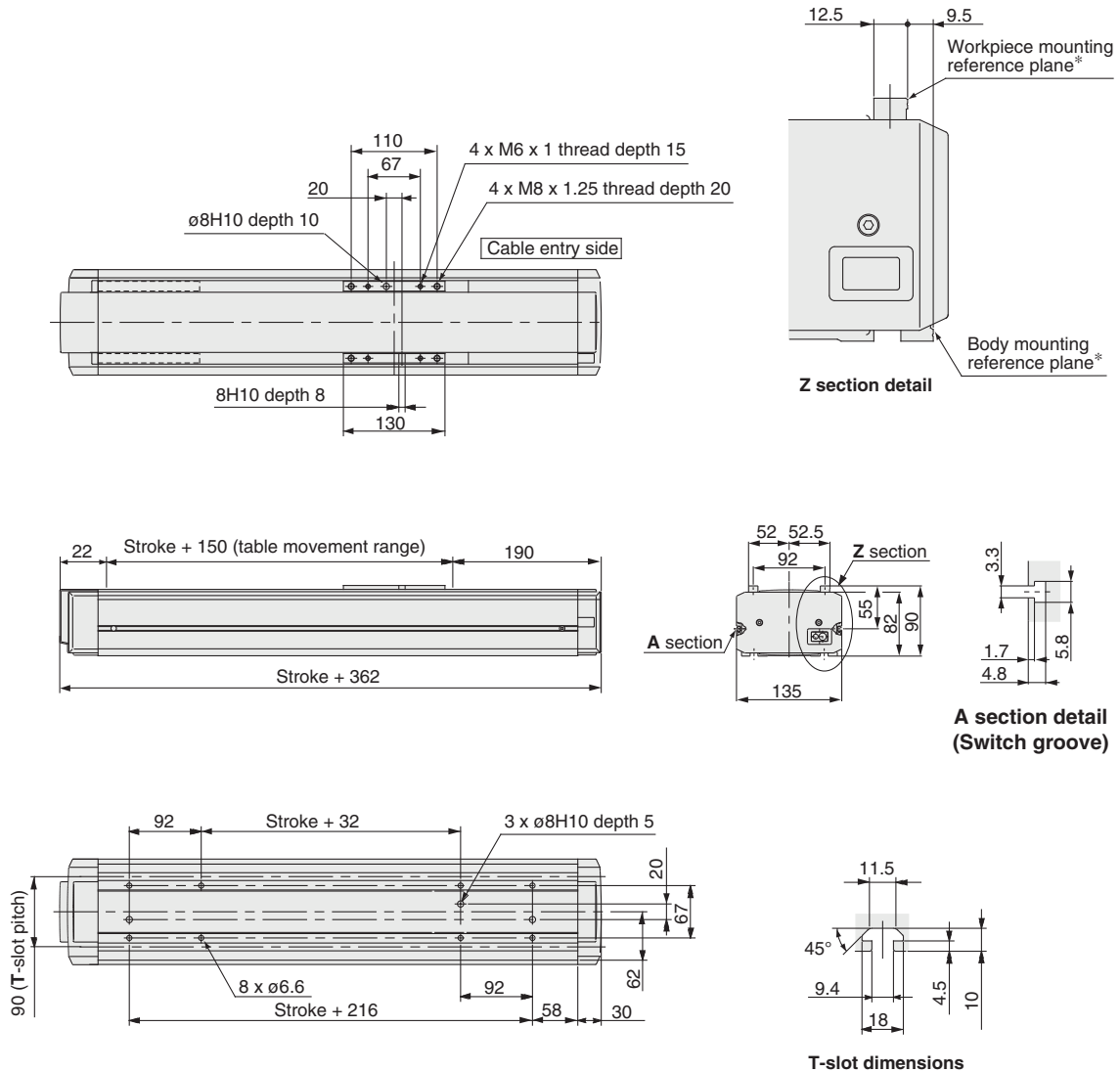

\* The body mounting reference plane and workpiece mounting reference plane should be used as standards when mounting onto equipment. Refer to pages starting with 830 for mounting.

## Positioning Time Guide

		Positioning time (sec.)				
		1	10	100	300	600
Speed (mm/s)	10	0.5	1.4	10.4	30.4	60.4
	100	0.5	0.6	1.5	3.5	6.5
	125	0.5	0.6	1.3	2.9	5.3
	250	0.5	0.6	0.9	1.7	2.9

\* Values will vary slightly depending on the operating conditions.

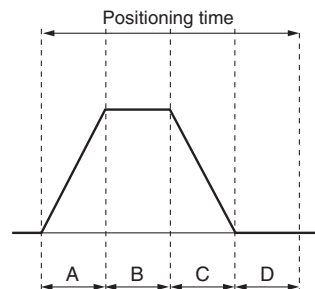

A: Acceleration time  
 B: Constant velocity time  
 C: Deceleration time  
 D: Resting time (0.4 sec.)  
 Maximum acceleration: 3000 mm/s<sup>2</sup>

LJ1

LG1

LTF

LECS□

LXF

LXP

LXS

LC6□

LZ□

LC3F2

D-□

E-MY

# Standard Motor Vertical Mount

Motor Output  
**100 W**

High Rigidity  
Direct Acting  
Guide

Rolled Ball Screw  
**∅15 mm/10 mm lead**

# Series LJ1H20



## How to Order

**LJ1H20 S2 NA - 300 K - F R 2 A1**

**Motor type**

<b>S2</b>	AC servo motor (Incremental encoder) 100 W
<b>S6</b>	AC servo motor (Absolute encoder) 100 W

**Stroke (mm)**  
Refer to the standard stroke.

**Cable entry direction**

<b>F</b>	Axial
<b>R</b>	Right
<b>L</b>	Left
<b>T</b>	Top
<b>B</b>	Bottom

**Cable type**

<b>S</b>	Standard cable
<b>R</b>	Robotic cable (flexible cable)

**Cable length**

<b>2</b>	2 m
<b>5</b>	5 m
<b>A</b>	10 m

**IO connector**

<b>Nil</b>	None
<b>H</b>	With IO connector

**Auto switch**

<b>Nil</b>	Without switch
<b>1</b>	NPN, A contact 1pc.
<b>2</b>	NPN, B contact 2pcs.
<b>3</b>	NPN, A contact 1pc., B contact 2pcs.
<b>4</b>	PNP, A contact 1pc.
<b>5</b>	PNP, B contact 2pcs.
<b>6</b>	PNP, A contact 1pc., B contact 2pcs.

**Driver type**

<b>Nil</b>	Without driver
<b>A1</b>	Pulse input type (Incremental encoder) 100 V
<b>A2</b>	Pulse input type (Incremental encoder) 200 V
<b>B1</b>	Pulse input type (Absolute encoder) 100 V
<b>B2</b>	Pulse input type (Absolute encoder) 200 V

## Specifications

	Standard stroke (mm)	100	200	300	400	500	600
Performance	Body weight (kg)	8.0	9.2	10.4	11.5	12.9	14.0
	Operating temperature range (°C)	5 to 40 (No condensation)					
	Work load (kg)	8					
	Maximum speed (mm/s)	500					
	Positioning repeatability (mm)	±0.05					
Main parts	Motor	AC servo motor (100W) with lock					
	Encoder	Incremental system/Absolute type					
	Lead screw	Rolled ball screw ∅15 mm, 10 mm lead					
	Guide	High rigidity direct acting guide					
	Motor/Screw connection	With coupling					
Driver	Model	LECS□□-□ (Refer to page 885 for details.)					

## Allowable Moment (N·m)

### Allowable static moment

Pitching	71
Yawing	75

**m** : Transfer load (kg)  
**a** : Workpiece acceleration (mm/s<sup>2</sup>)  
**Me** : Dynamic moment  
**L** : Overhang to workpiece center of gravity (mm)

### Allowable dynamic moment

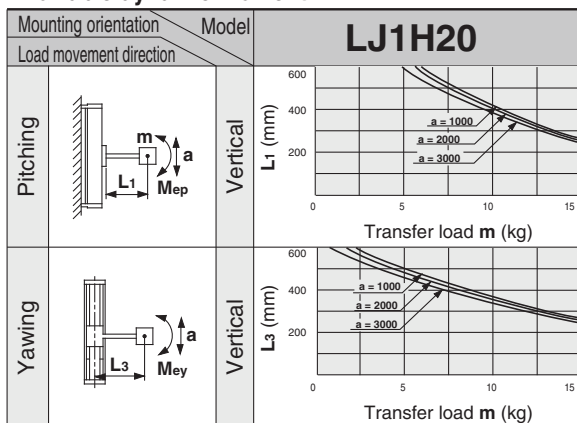

Refer to page 833 for deflection data.

Note) When using this product, the regeneration option may be required.

## Investigation of the regeneration option

Depending on the conditions (speed, addition-subtraction speed, down time, load, etc.), the regeneration option may be required. The results of consideration in each case of maximum load or half load for the product specification are below. Please consult SMC when considering the necessity of the regeneration option.

### Maximum load

Driver type	Regeneration option model
<b>A1</b>	LEC-MR-RB-032
<b>A2</b>	LEC-MR-RB-032
<b>B1</b>	LEC-MR-RB-032
<b>B2</b>	LEC-MR-RB-032

### Half load

Driver type	Regeneration option model
<b>A1</b>	LEC-MR-RB-032
<b>A2</b>	LEC-MR-RB-032
<b>B1</b>	LEC-MR-RB-032
<b>B2</b>	LEC-MR-RB-032

## Dimensions/LJ1H20□NA

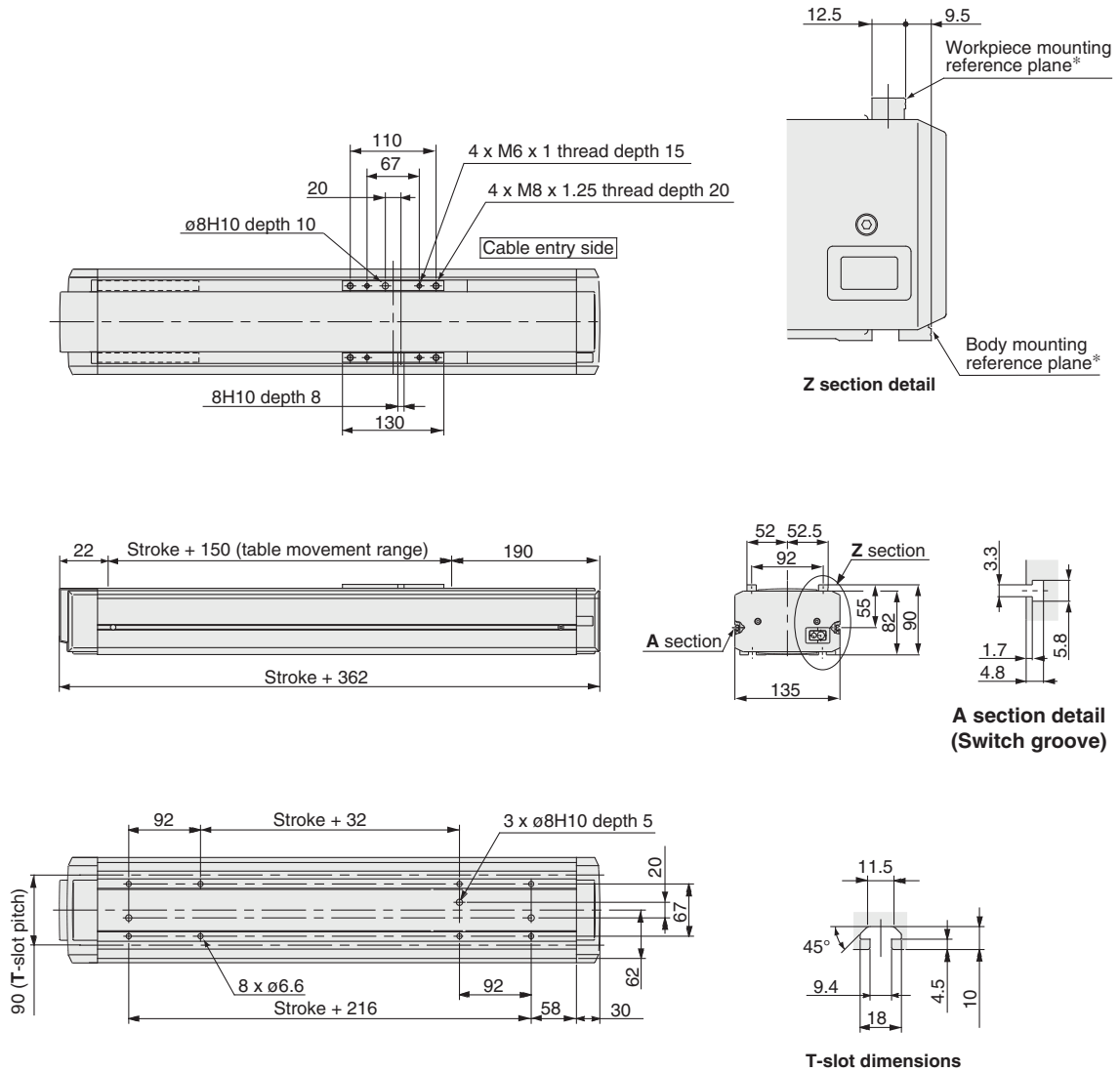

\* The body mounting reference plane and workpiece mounting reference plane should be used as standards when mounting onto equipment. Refer to pages starting with 830 for mounting.

## Positioning Time Guide

		Positioning time (sec.)				
		1	10	100	300	600
Speed (mm/s)	10	0.5	1.4	10.4	30.4	60.4
	100	0.5	0.6	1.5	3.5	6.5
	250	0.5	0.6	0.9	1.7	2.9
	500	0.5	0.6	0.8	1.2	1.8

\* Values will vary slightly depending on the operating conditions.

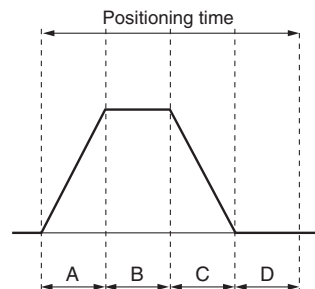

A: Acceleration time  
 B: Constant velocity time  
 C: Deceleration time  
 D: Resting time (0.4 sec.)  
 Maximum acceleration: 3000 mm/s<sup>2</sup>

- LJ1
- LG1
- LTF
- LECS□
- LXF
- LXP
- LXS
- LC6□
- LZ□
- LC3F2
- D-□
- E-MY

# Standard Motor Vertical Mount

Motor Output  
**200 W**

High Rigidity  
Direct Acting  
Guide

Ground Ball Screw  
**∅20 mm/10 mm lead**

# Series LJ1H30



## How to Order

**LJ1H30 S3 PA - 300 K - F R 2 A1** - [ ] - [ ]

**Motor type**

<b>S3</b>	AC servo motor (Incremental encoder) 200 W
<b>S7</b>	AC servo motor (Absolute encoder) 200 W

**Stroke (mm)**  
Refer to the standard stroke.

**Cable entry direction**

<b>F</b>	Axial
<b>R</b>	Right
<b>L</b>	Left
<b>T</b>	Top
<b>B</b>	Bottom

**Cable type**

<b>S</b>	Standard cable
<b>R</b>	Robotic cable (flexible cable)

**Cable length**

<b>2</b>	2 m
<b>5</b>	5 m
<b>A</b>	10 m

**IO connector**

<b>Nil</b>	None
<b>H</b>	With IO connector

**Auto switch**

Nil	Without switch
<b>1</b>	NPN, A contact 1pc.
<b>2</b>	NPN, B contact 2pcs.
<b>3</b>	NPN, A contact 1pc., B contact 2pcs.
<b>4</b>	PNP, A contact 1pc.
<b>5</b>	PNP, B contact 2pcs.
<b>6</b>	PNP, A contact 1pc., B contact 2pcs.

**Driver type**

Nil	Without driver
<b>A1</b>	Pulse input type (Incremental encoder) 100 V
<b>A2</b>	Pulse input type (Incremental encoder) 200 V
<b>B1</b>	Pulse input type (Absolute encoder) 100 V
<b>B2</b>	Pulse input type (Absolute encoder) 200 V

## Specifications

Standard stroke (mm)		200	300	400	500	600
Performance	Body weight (kg)	16.3	18.3	20.3	22.3	24.3
	Operating temperature range (°C)	5 to 40 (No condensation)				
	Work load (kg)	20				
	Maximum speed (mm/s)	500				
	Positioning repeatability (mm)	±0.02				
Main parts	Motor	AC servo motor (200 W) with lock				
	Encoder	Incremental system/Absolute type				
	Lead screw	Ground ball screw ∅20 mm, 10 mm lead				
	Guide	High rigidity direct acting guide				
	Motor/Screw connection	With coupling				
Driver	Model	LECS□□-□ (Refer to page 885 for details.)				

## Allowable Moment (N·m)

### Allowable static moment

Pitching	117
Yawing	123

**m** : Transfer load (kg)  
**a** : Workpiece acceleration (mm/s<sup>2</sup>)  
**Me** : Dynamic moment  
**L** : Overhang to workpiece center of gravity (mm)

### Allowable dynamic moment

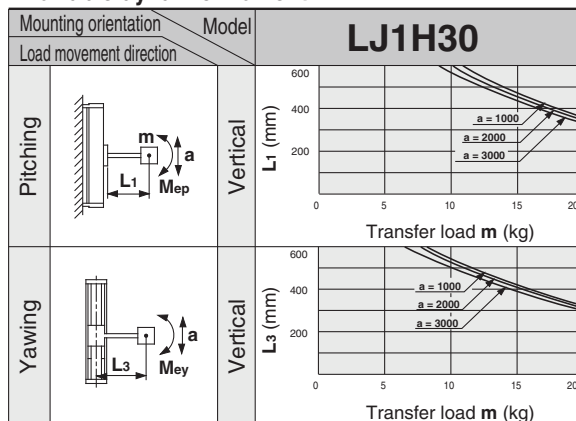

Refer to page 833 for deflection data.

Note) When using this product, the regeneration option may be required.

## Investigation of the regeneration option

Depending on the conditions (speed, addition-subtraction speed, down time, load, etc.), the regeneration option may be required.

The results of consideration in each case of maximum load or half load for the product specification are below.

Please consult SMC when considering the necessity of the regeneration option.

### Maximum load

Driver type	Regeneration option model
<b>A1</b>	<b>LEC-MR-RB-12</b>
<b>A2</b>	<b>LEC-MR-RB-12</b>
<b>B1</b>	<b>LEC-MR-RB-12</b>
<b>B2</b>	<b>LEC-MR-RB-12</b>

### Half load

Driver type	Regeneration option model
<b>A1</b>	<b>LEC-MR-RB-032</b>
<b>A2</b>	<b>LEC-MR-RB-032</b>
<b>B1</b>	<b>LEC-MR-RB-032</b>
<b>B2</b>	<b>LEC-MR-RB-032</b>

**Dimensions/LJ1H30□PA**

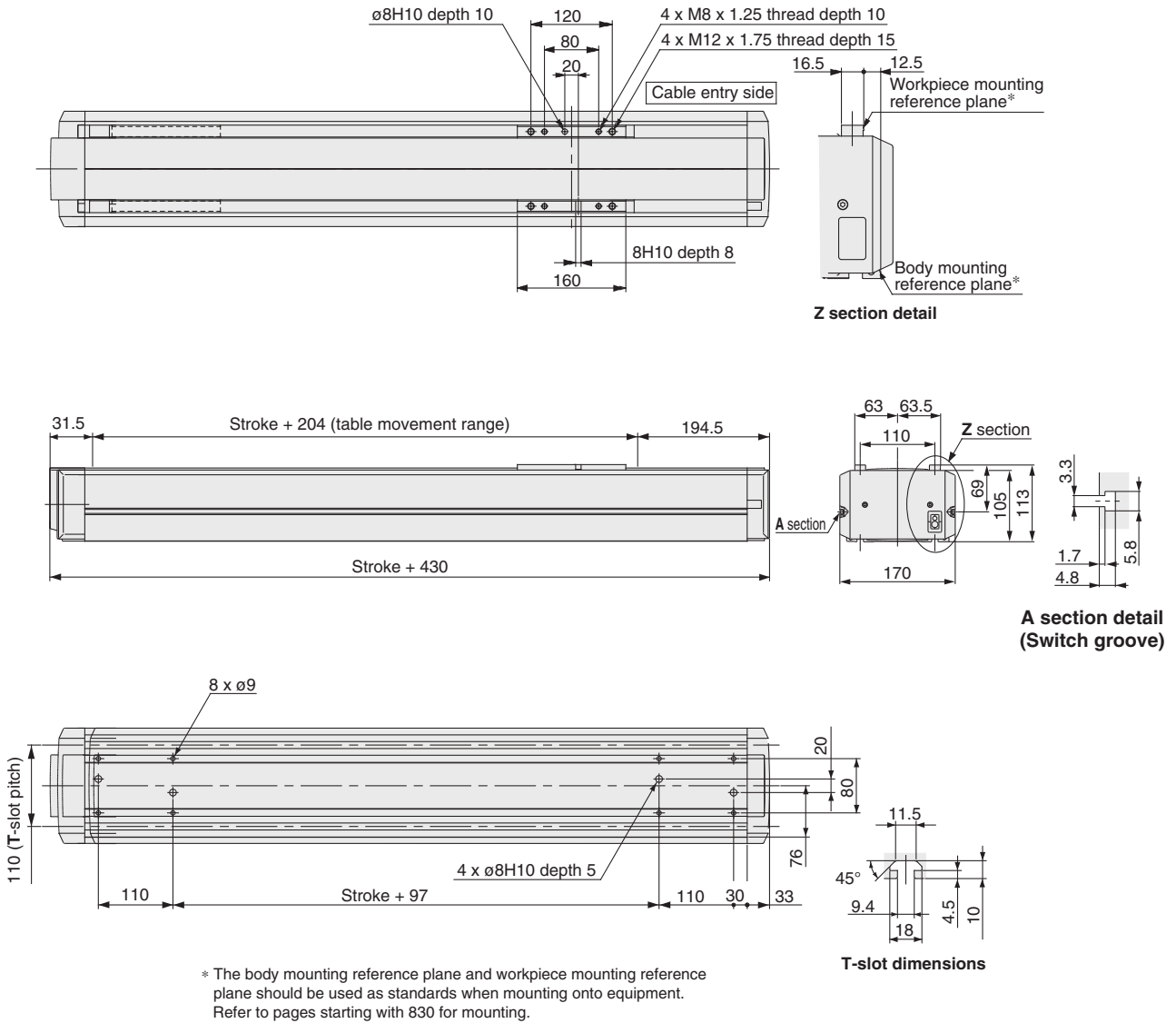

- LJ1**
- LG1**
- LTF**
- LECS□**
- LXF**
- LXP**
- LXS**
- LC6□**
- LZ□**
- LC3F2**
- D-□**
- E-MY**

**Positioning Time Guide**

		Positioning time (sec.)				
		1	10	100	300	600
Speed (mm/s)	10	1.1	2.0	11.0	31.0	61.0
	100	1.1	1.2	2.1	4.1	7.1
	250	1.1	1.2	1.5	2.3	3.5
	500	1.1	1.2	1.4	1.8	2.4

\* Values will vary slightly depending on the operating conditions.

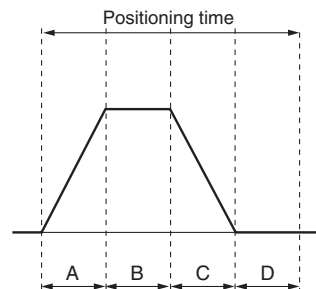

A: Acceleration time  
 B: Constant velocity time  
 C: Deceleration time  
 D: Resting time (1.0 sec.)  
 Maximum acceleration: 3000 mm/s<sup>2</sup>

# Standard Motor Vertical Mount

Motor Output  
**200 W**

High Rigidity  
Direct Acting  
Guide

Rolled Ball Screw  
**∅20 mm/10 mm lead**

# Series LJ1H30



## How to Order

**LJ1H30 S3 NA - 300 K - F R 2 A1** - [ ] - [ ]

**Motor type**

<b>S3</b>	AC servo motor (Incremental encoder) 200 W
<b>S7</b>	AC servo motor (Absolute encoder) 200 W

**Stroke (mm)**  
Refer to the standard stroke.

**Cable type**

<b>S</b>	Standard cable
<b>R</b>	Robotic cable (flexible cable)

**Cable length**

<b>2</b>	2 m
<b>5</b>	5 m
<b>A</b>	10 m

**Cable entry direction**

<b>F</b>	Axial
<b>R</b>	Right
<b>L</b>	Left
<b>T</b>	Top
<b>B</b>	Bottom

**IO connector**

<b>Nil</b>	None
<b>H</b>	With IO connector

**Driver type**

<b>Nil</b>	Without driver
<b>A1</b>	Pulse input type (Incremental encoder) 100 V
<b>A2</b>	Pulse input type (Incremental encoder) 200 V
<b>B1</b>	Pulse input type (Absolute encoder) 100 V
<b>B2</b>	Pulse input type (Absolute encoder) 200 V

**Auto switch**

<b>Nil</b>	Without switch
<b>1</b>	NPN, A contact 1pc.
<b>2</b>	NPN, B contact 2pcs.
<b>3</b>	NPN, A contact 1pc., B contact 2pcs.
<b>4</b>	PNP, A contact 1pc.
<b>5</b>	PNP, B contact 2pcs.
<b>6</b>	PNP, A contact 1pc., B contact 2pcs.

**Cable entry direction**

## Specifications

	Standard stroke (mm)	200	300	400	500	600
<b>Performance</b>	Body weight (kg)	16.3	18.3	20.3	22.3	24.3
	Operating temperature range (°C)	5 to 40 (No condensation)				
	Work load (kg)	20				
	Maximum speed (mm/s)	500				
	Positioning repeatability (mm)	±0.05				
<b>Main parts</b>	Motor	AC servo motor (200 W) with lock				
	Encoder	Incremental system/Absolute type				
	Lead screw	Rolled ball screw ∅20 mm, 10 mm lead				
	Guide	High rigidity direct acting guide				
	Motor/Screw connection	With coupling				
<b>Driver</b>	<b>Model</b>	LECS□□-□ (Refer to page 885 for details.)				

## Allowable Moment (N·m)

### Allowable static moment

Pitching	117
Yawing	123

**m** : Transfer load (kg)  
**a** : Workpiece acceleration (mm/s<sup>2</sup>)  
**Me** : Dynamic moment  
**L** : Overhang to workpiece center of gravity (mm)

### Allowable dynamic moment

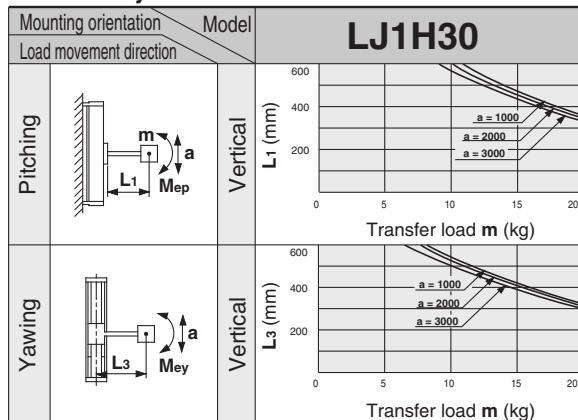

Refer to page 833 for deflection data.

Note) When using this product, the regeneration option may be required.

## Investigation of the regeneration option

Depending on the conditions (speed, addition-subtraction speed, down time, load, etc.), the regeneration option may be required. The results of consideration in each case of maximum load or half load for the product specification are below. Please consult SMC when considering the necessity of the regeneration option.

### Maximum load

Driver type	Regeneration option model
<b>A1</b>	<b>LEC-MR-RB-12</b>
<b>A2</b>	<b>LEC-MR-RB-12</b>
<b>B1</b>	<b>LEC-MR-RB-12</b>
<b>B2</b>	<b>LEC-MR-RB-12</b>

### Half load

Driver type	Regeneration option model
<b>A1</b>	<b>LEC-MR-RB-032</b>
<b>A2</b>	<b>LEC-MR-RB-032</b>
<b>B1</b>	<b>LEC-MR-RB-032</b>
<b>B2</b>	<b>LEC-MR-RB-032</b>



## Dimensions/LJ1H30□NA

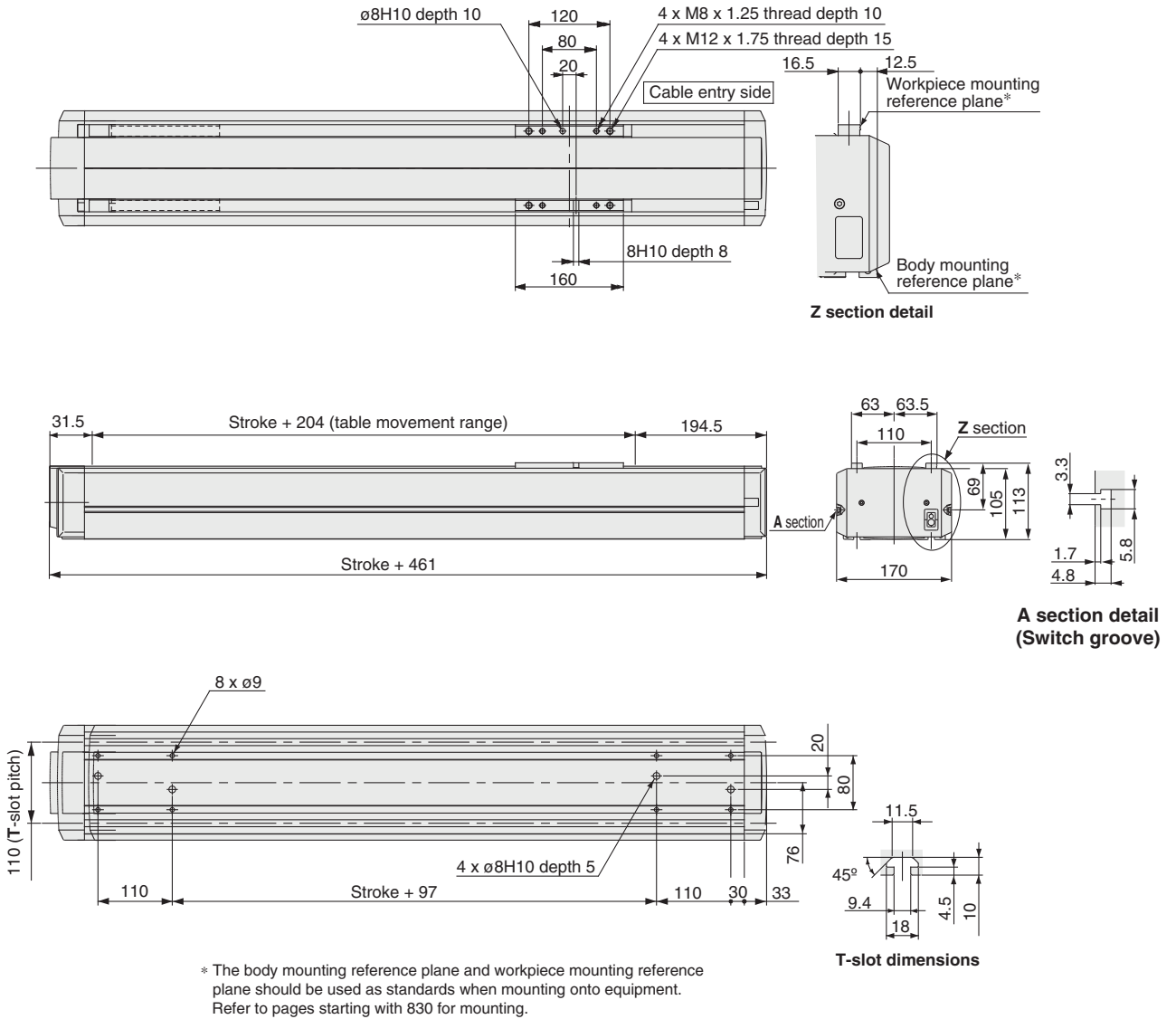

## Positioning Time Guide

		Positioning time (sec.)				
Positioning distance (mm)		1	10	100	300	600
Speed (mm/s)	10	0.5	2.0	11.0	31.0	61.0
	100	1.1	1.2	2.1	4.1	7.1
	250	1.1	1.2	1.5	2.3	3.5
	500	1.1	1.2	1.4	1.8	2.4

\* Values will vary slightly depending on the operating conditions.

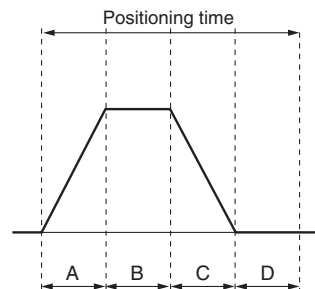

A: Acceleration time  
 B: Constant velocity time  
 C: Deceleration time  
 D: Resting time (1.0 sec.)  
 Maximum acceleration: 3000 mm/s<sup>2</sup>

LJ1

LG1

LTF

LECS□

LXF

LXP

LXS

LC6□

LZ□

LC3F2

D-□

E-MY

# Series LJ1 Options

## T-nuts for Mounting Electric Actuators

Use T-nuts for T-slot mounting of an actuator. When mounting by means of T-nuts alone, the quantity of nuts indicated below should be used as a minimum.

Model **LJ1-T8** (Weight 8.4 g)

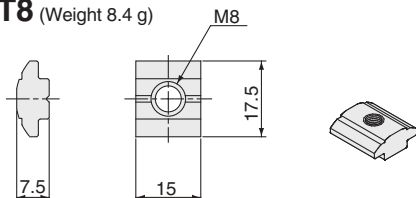

### T-nut quantity

Model	Quantity
<b>LJ1H10</b>	200 mm stroke or less: 6 pcs.
	300 mm stroke or more: 8 pcs.
<b>LJ1H20</b>	8 pcs.
<b>LJ1H30</b>	8 pcs.

\* Only series LJ1H10 has the T-nuts built into the body.

# Series LJ1H Construction

## Construction

### LJ1H10

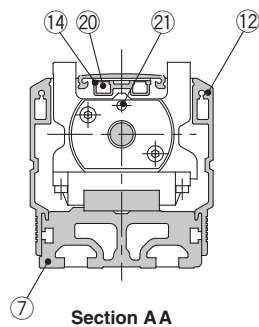
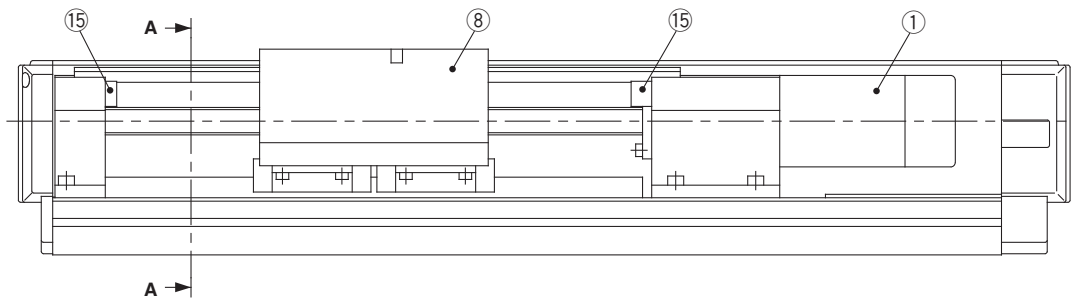
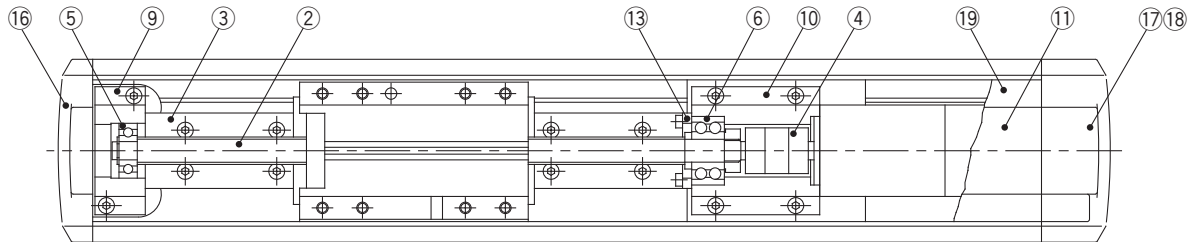

#### Parts list

No.	Description	Material	Note
1	AC servo motor	—	100 W
2	Lead screw	—	Ball screw
3	High rigidity direct acting guide	—	
4	Coupling	—	
5	Bearing R	—	
6	Bearing F	—	
7	Body A	Aluminum alloy	
8	Table	Aluminum alloy	
9	Housing A	Aluminum alloy	
10	Housing B	Aluminum alloy	
11	Top cover	Aluminum alloy	

No.	Description	Material	Note
12	Side cover	Aluminum alloy	
13	Bearing retainer	Aluminum alloy	
14	Sensor rail	Aluminum alloy	
15	Bumper	IIR	
16	End cover A	PC	
17	End cover B	PC	
18	Inner cover	PC	
19	Motor cover	PC	
20	Auto switch	—	
21	Magnet	—	

LJ1

LG1

LTF

LECS□

LXF

LXP

LXS

LC6□

LZ□

LC3F2

D-□

E-MY

# Series LJ1H

## Construction

### LJ1H20

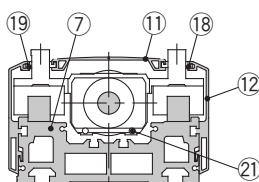
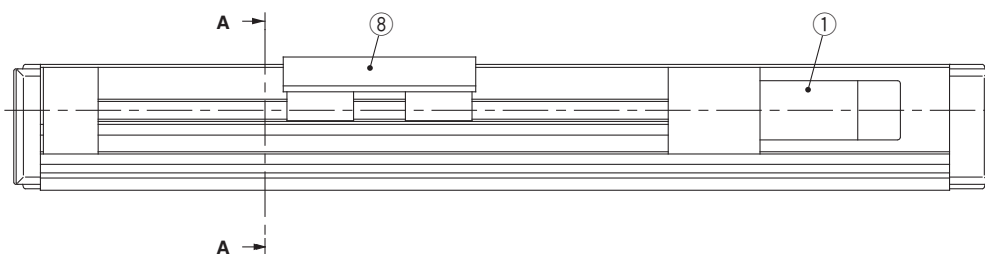
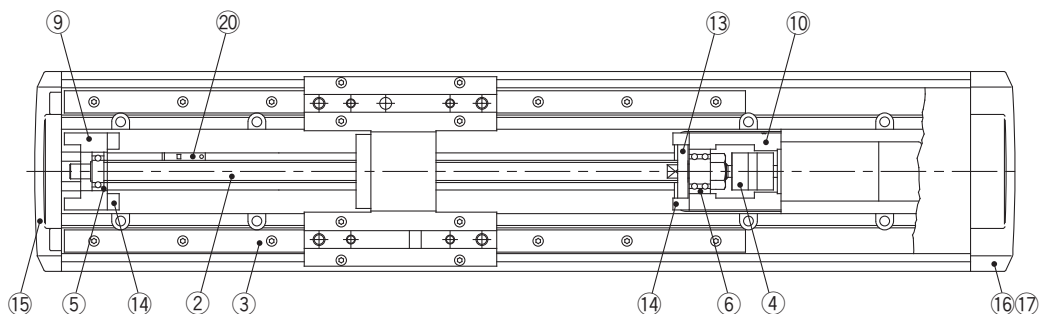

Section AA

#### Parts list

No.	Description	Material	Note
1	AC servo motor	—	100 W
2	Lead screw	—	Ball screw
3	High rigidity direct acting guide	—	
4	Coupling	—	
5	Bearing R	—	
6	Bearing F	—	
7	Body A	Aluminum alloy	
8	Table	Aluminum alloy	
9	Housing A	Aluminum alloy	
10	Housing B	Aluminum alloy	
11	Top cover	Aluminum alloy	

No.	Description	Material	Note
12	Side cover	Aluminum alloy	
13	Bearing retainer	Aluminum alloy	
14	Bumper	IIR	
15	End cover A	PC	
16	End cover B	PC	
17	Inner cover	PC	
18	Motor cover R	PC	
19	Motor cover L	PC	
20	Auto switch	—	
21	Magnet	—	

**Construction**

**LJ1H30**

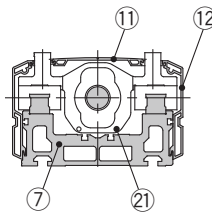
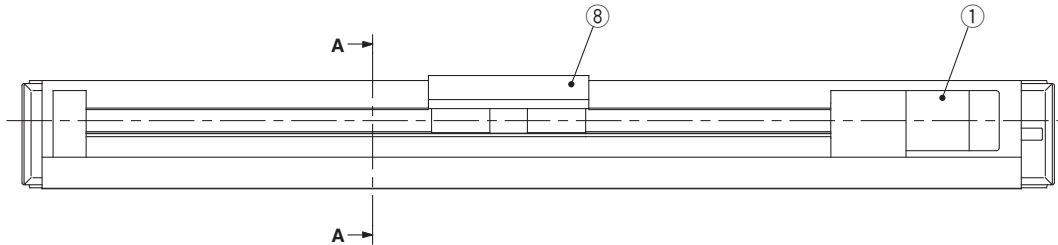
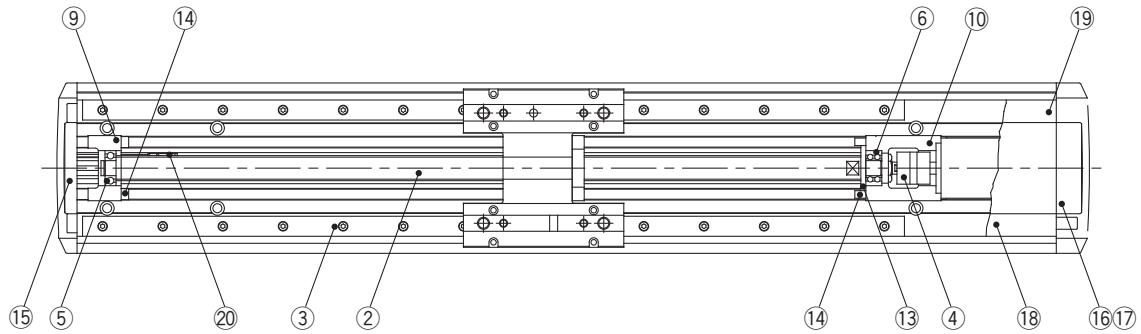

Section AA

**Parts list**

No.	Description	Material	Note
1	AC servo motor	—	200 W
2	Lead screw	—	Ball screw
3	High rigidity direct acting guide	—	
4	Coupling	—	
5	Bearing R	—	
6	Bearing F	—	
7	Body A	Aluminum alloy	
8	Table	Aluminum alloy	
9	Housing A	Aluminum alloy	
10	Housing B	Aluminum alloy	
11	Top cover	Aluminum alloy	

No.	Description	Material	Note
12	Side cover	Aluminum alloy	
13	Bearing retainer	Carbon steel	Electroless nickel plated
14	Bumper	IIR	
15	End cover A	PC	
16	End cover B	PC	
17	Inner cover	PC	
18	Motor cover A	PC	
19	Motor cover B	PC	
20	Auto switch	—	
21	Magnet	—	

LJ1

LG1

LTF

LECS

LXF

LXP

LXS

LC6

LZ

LC3F2

D-

E-MY

# Series LJ1 Mounting

## T-slot Bottom Mount

### LJ1H10

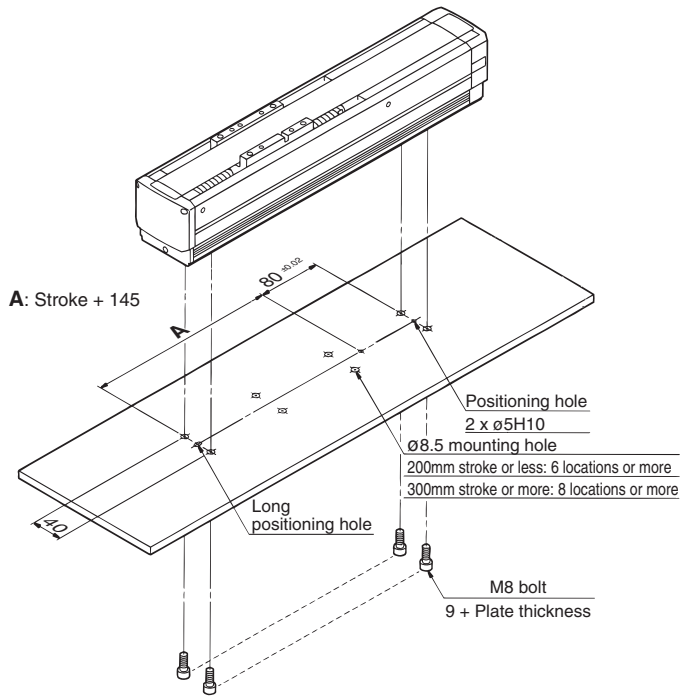

### LJ1H20

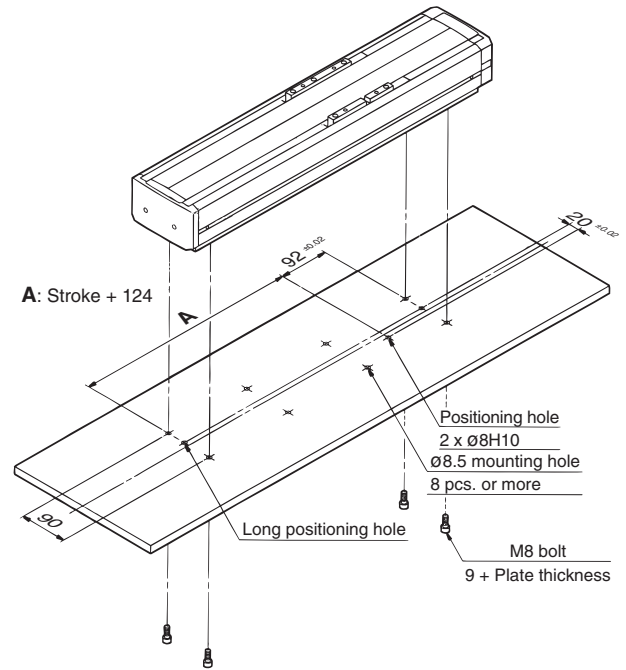

### LJ1H30

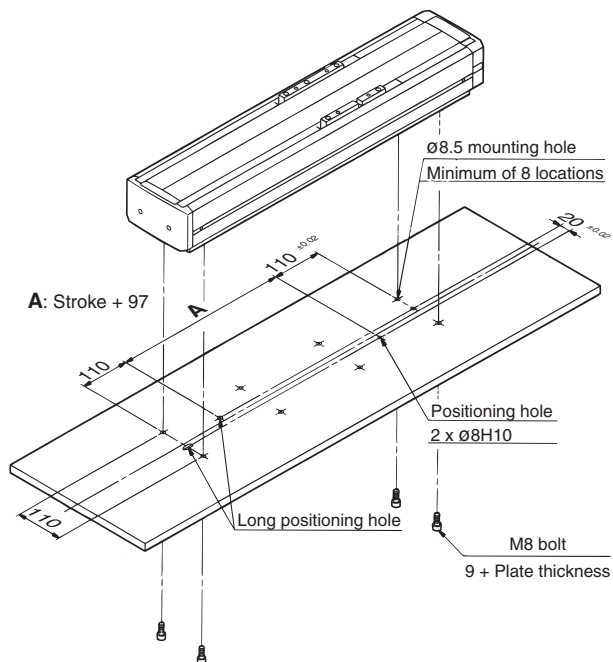

Note 1) Although T-nuts (LJ1-T8) for mounting are included with the body for LJ1H10, they are optional for other models. (See page 826.)

Note 2) To insert the T-nuts, remove the covers at both ends of the body and insert them into the T-slots.

Note 3) When positioning of the body is required, also perform pin hole machining.

**Top Mount**

**LJ1H20**

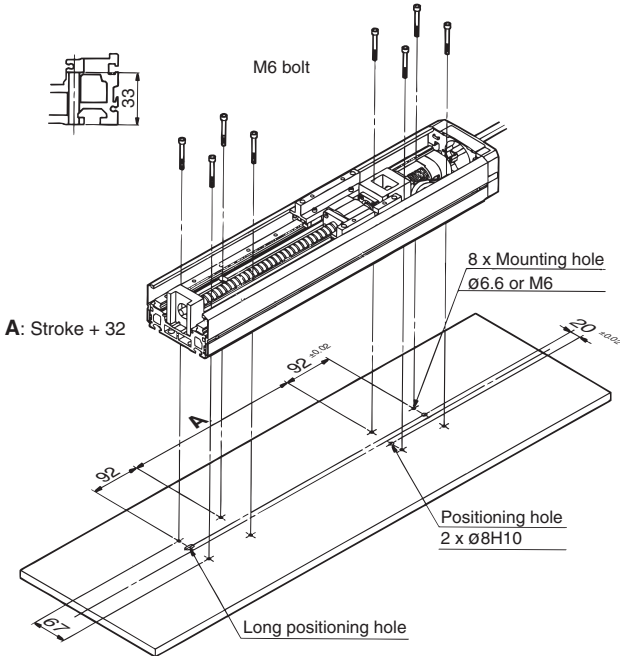

**LJ1H30**

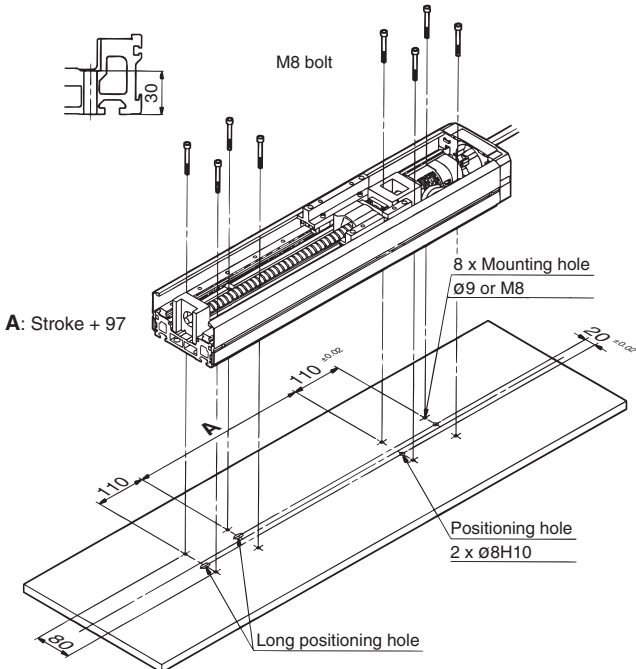

- LJ1**
- LG1**
- LTF**
- LECS
- LXF**
- LXP**
- LXS**
- LC6
- LZ
- LC3F2
- D-
- E-MY



# Series LJ1

## Top Mount (Using T-slots on the Mounting Frame)

### LJ1H20

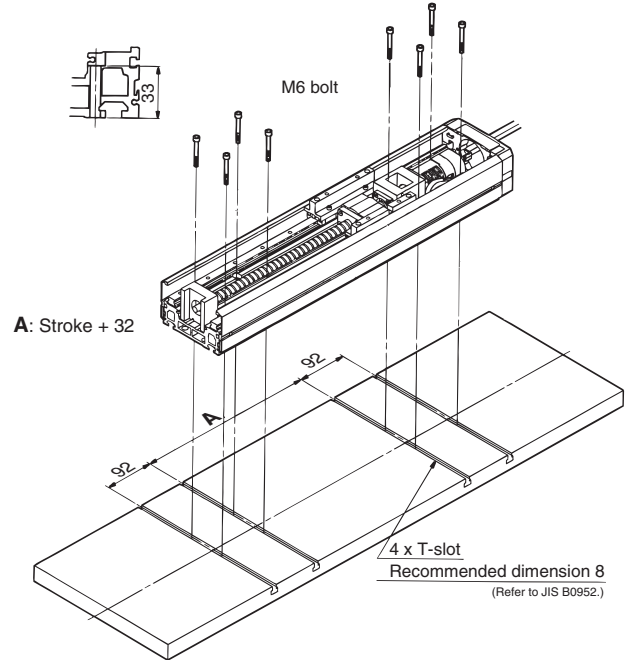
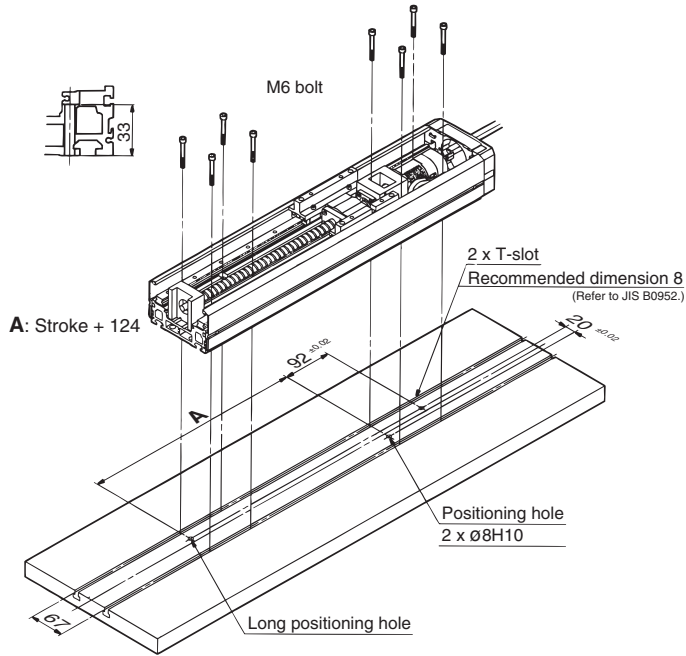

### LJ1H30

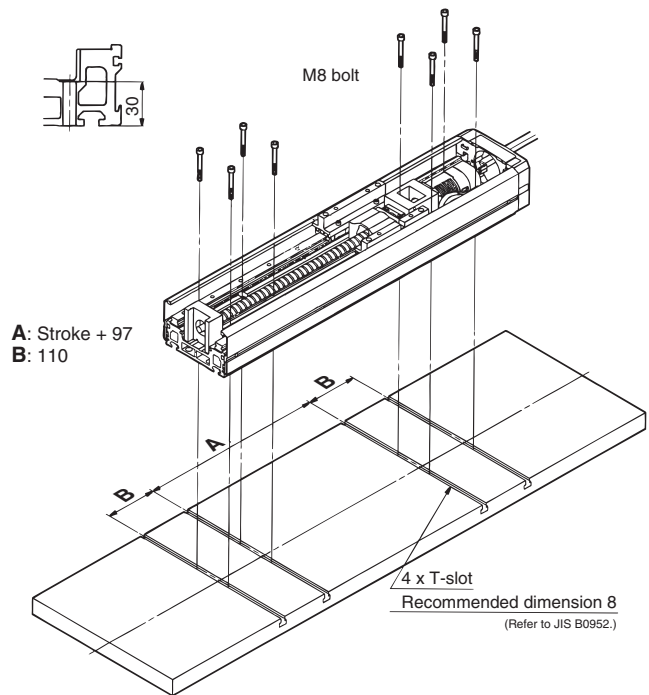
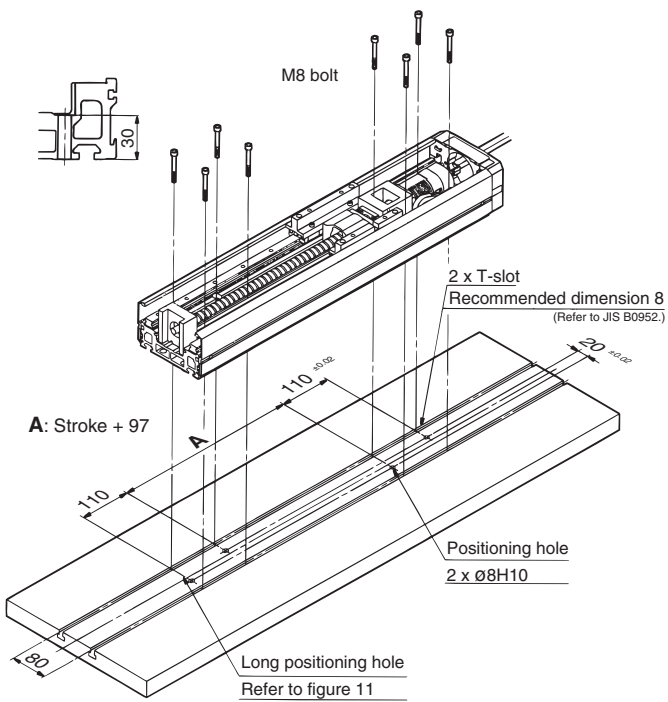

# Series LJ1 Deflection Data

## Deflection Data/LJ1H

\* Calculated values based on the body's geometric moment of inertia.

The load and the amount of deflection at load point W are shown in the graphs below for each series.

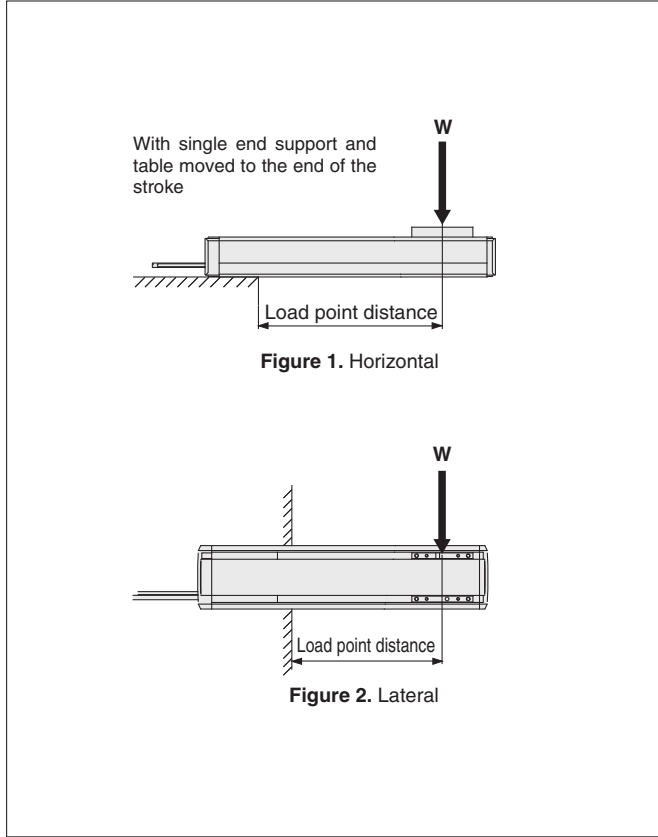

### LJ1H10

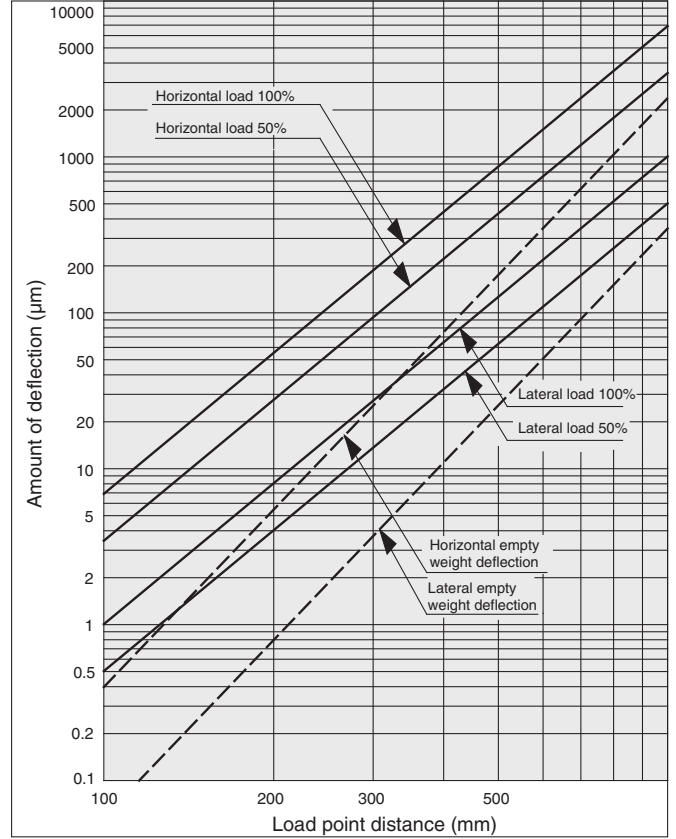

### LJ1H20

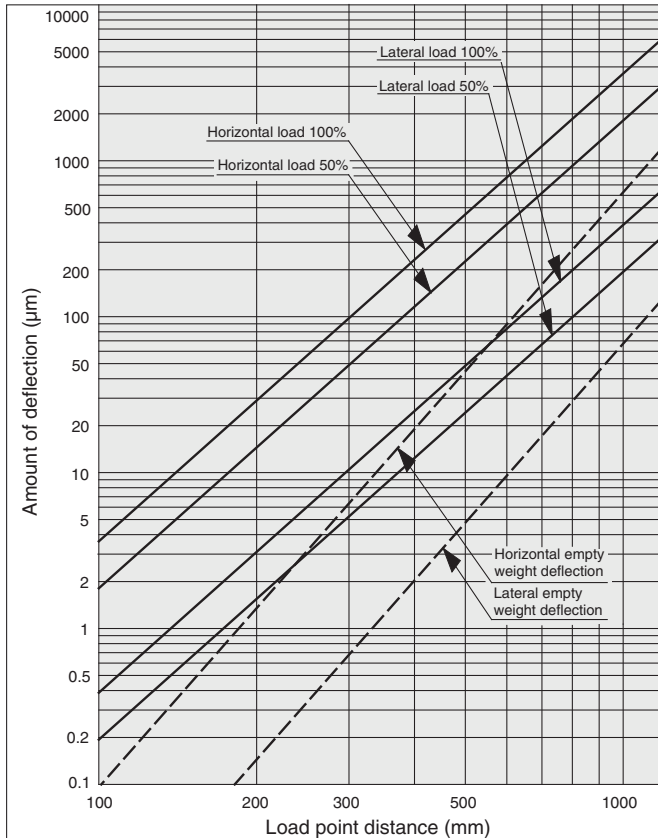

### LJ1H30

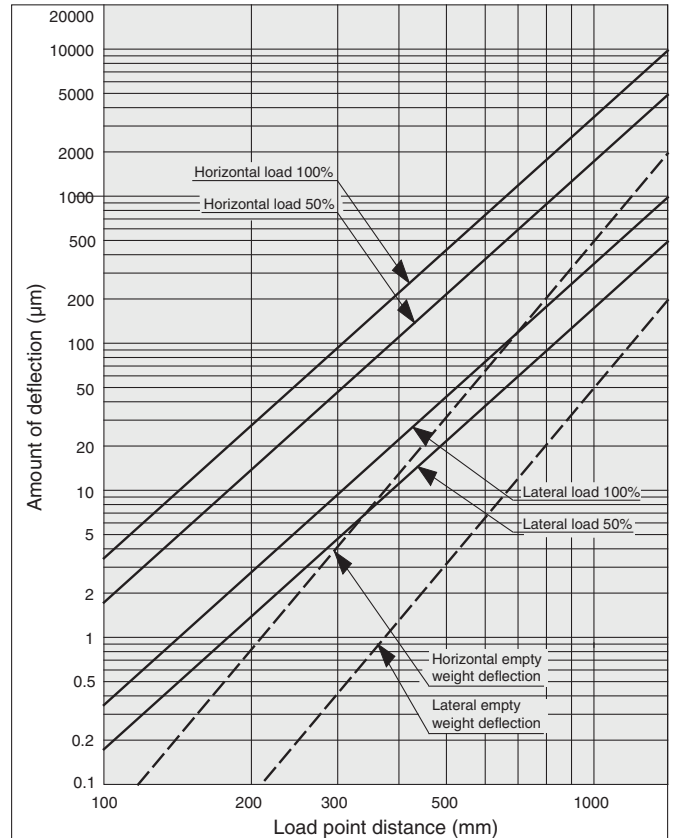

LJ1

LG1

LTF

LECS

LXF

LXP

LXS

LC6

LZ

LC3F2

D-

E-MY