

Stroke Reading Cylinder with Brake

CE2 Series

ø40, ø50, ø63, ø80, ø100



(Note) CE-compliant: When connecting to a multi-counter (CEU5□□-D, power supply voltage 24 VDC). Refer to the counter operation manual for details.



How to Order

The Controller CEU2/CEU2P series was discontinued in November 2019. Please contact your local sales representative for more details.

CEP1
CE1
CE2
ML2B

CE2 B 40 - **100** - **M9BW**

Mounting type

B	Basic type
L	Foot type
F	Rod side flange type
G	Head side flange type
C	Single clevis type
D	Double clevis type
T	Center trunnion type

Bore size

40	40 mm
50	50 mm
63	63 mm
80	80 mm
100	100 mm

Port thread type

Nil	Rc
TN	NPT
TF	G

Number of auto switches

Nil	2 pcs.
S	1 pc.
n	"n" pcs.

Applicable counter

CEU5 series

Suffix for cylinder

Rod boot	J	Nylon tarpaulin
	K	Neoprene cross
Cushion	Nil	With cushion on both ends
	N	Without cushion
	R	With rod cushion
	H	With head cushion
Connector	Nil	With connector
	Z	Without connector

Auto switch

Nil	Without auto switch (Built-in magnet)
-----	---------------------------------------

* For the applicable auto switch model, refer to the table below.

Cylinder stroke (mm)
Refer to "Standard Stroke" on page 686.

Applicable Auto Switches

Refer to pages 941 to 1067 for further information on auto switches.

Type	Special function	Electrical entry	Indicator light	Wiring (Output)	Load voltage		Auto switch model		Lead wire length (m)				Pre-wired connector	Applicable load												
					DC	AC	Tie-rod mounting	Band mounting	0.5 (Nil)	1 (M)	3 (L)	5 (Z)		IC circuit	Relay, PLC											
Solid state auto switch	—	Grommet	—	3-wire (NPN)	24V	5 V, 12 V	—	M9N	●	●	●	○	—	—	—	—										
				3-wire (PNP)				—	—	—	—	—					—	—	—	—						
		Terminal conduit	—	2-wire	12 V	—	M9B	—	—	—	—	—	—	—	—	—	—									
				3-wire (NPN)			G39C	G39	—	—	—	—	—					—	—							
	Diagnostic indication (2-color indicator)	Grommet	Yes	—	2-wire	24V	5 V, 12 V	—	K39C	K39	—	—	—	—	—	—	—									
					3-wire (NPN)				M9NW	—	●	●	●	○				—	—	—						
					3-wire (PNP)				—	G59W	—	●	●	○							—	—	—			
					2-wire				M9PW	—	●	●	●	○				—	—	—						
					3-wire (NPN)				—	G5PW	—	●	●	○							—	—	—			
					3-wire (PNP)				M9BW	—	●	●	●	○				—	—	—						
2-wire	—	K59W	—	●	●	○	—	—	—																	
Water resistant (2-color indicator)	Grommet	—	—	3-wire (NPN)	24V	5 V, 12 V				—	M9NA*1	—	○	○	○	—	—	—	—							
3-wire (PNP)				M9PA*1			—	○	○		○	—	—	—												
2-wire				M9BA*1			—	○	○		○				—					—	—					
4-wire (NPN)				—			G5BA*1	—	●		●	○	—	—								—				
With diagnostic output (2-color indicator)	Grommet	Yes	—	3-wire (NPN equivalent)	24V	5 V	—	F59F	G59F	●	—	●			○	—	—	—								
—				2-wire				24V	12 V	—	A96**	—	●	●	●				—	—	—	—	—	—		
Diagnostic indication (2-color indicator)	Terminal conduit	Yes	—	2-wire	100 V	A93**	—				●	●	●	—	—	—	—	—	—							
					100 V or less	A90**	—				●	●	—	—											—	—
					100 V, 200 V	A54	B54				●	—	●													
					200 V or less	A64	B64				●	—	●	—											—	—
					—	A33C	A33				—	—	—													
					100 V, 200 V	A34C	A34	—	—	—	—	—	—													
—	A44C	A44	—	—	—	—	—	—																		
—	A59W	B59W	●	—	●				—	—	—															

*1 Water resistant type auto switches can be mounted on the above models, but in such case SMC cannot guarantee water resistance. Consult with SMC regarding water resistant types with the above model numbers.

* Lead wire length symbols: 0.5 m..... Nil (Example) M9NW
1 m..... M (Example) M9NWM
3 m..... L (Example) M9NWL
5 m..... Z (Example) M9NWX

* Solid state auto switches marked with "○" are produced upon receipt of order.
** Since D-A9□ and D-A9□V cannot be mounted on ø50, use of D-Z7□ or D-Z80 is recommended.

* Since there are other applicable auto switches than listed, refer to page 697 for details.
* For details about auto switches with pre-wired connector, refer to pages 1014 and 1015.
* D-A9□/M9□/M9□W/M9□(A/V) auto switches are shipped together (not assembled). (Only auto switch mounting brackets are assembled before shipped.)



D-□

-X□

CE2 Series

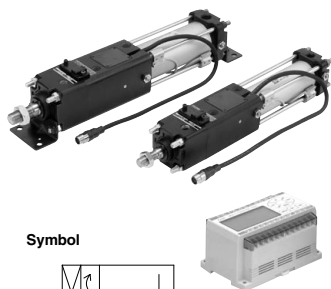

Symbol

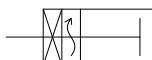

Model

Series	Type	Action	Bore size (mm)	Lock action
CE2	Non-lube	Double acting	40, 50, 63, 80, 100	Spring and pneumatic lock

Rod Boot Material

Symbol	Rod boot material	Maximum ambient temperature
J	Nylon tarpaulin	60°C
K	Neoprene cross	110°C*

* Maximum ambient temperature for the rod boot itself.

As for multi counter, it will be common to CEP1 and CE1 series. For details, refer to Multi counter/CEU5 on page 667 respectively.

Refer to pages 692 to 697 for cylinders with auto switches.

- Auto switch proper mounting position (detection at stroke end) and its mounting height
- Operating range
- Minimum stroke for auto switch mounting
- Auto switch mounting brackets/Part no.

Cylinder Specifications

Bore size (mm)		ø40	ø50	ø63	ø80	ø100
Fluid		Air (Non-lube)				
Proof pressure	Drive	1.5 MPa				
	Brake	0.75 MPa				
Maximum operating pressure	Drive	1 MPa				
	Brake	0.5 MPa				
Minimum operating pressure	Drive	0.1 MPa				
	Brake	0.3 MPa				
Piston speed		50 to 500 mm/s*				
Ambient temperature		00 to 60°C (No freezing)				
Brake system		Spring and pneumatic lock type				
Sensor cord length		ø7-500 mm Oil-resistant				
Stroke length tolerance		Up to 250 mm: $\begin{smallmatrix} +1.0 \\ 0 \end{smallmatrix}$; 251 mm to 1000 mm $\begin{smallmatrix} +1.4 \\ 0 \end{smallmatrix}$				

* Be aware of the constraints in the allowable kinetic energy.

Sensor Specifications

Cable	ø7, 6 core twisted pair shielded wire (Oil, Heat and Flame resistant cable)
Maximum transmission distance	20.5 m (when using SMC cable while using controller or counter)
Position detection method	Magnetic scale rod/Sensor head <Incremental type>
Magnetic field resistance	14.5 mT
Power supply	10.8 to 26.4 VDC (Power supply ripple: 1% or less)
Current consumption	50 mA
Resolution	0.1 mm/pulse
Accuracy	± 0.2 mm (Note)
Output type	Open collector (Max. 30 VDC, 50 mA)
Output signal	A/B phase difference output
Insulation resistance	50 MΩ or more (500 VDC measured via megohmmeter) (between case and 12E)
Vibration resistance	33.3 Hz, 6.8 G 2 hrs. each in X, Y directions 4 hrs. in Z direction based upon JIS D 1601
Impact resistance	30 G, 3 times at X, Y, Z
Enclosure	IP65 (IEC standard) Except connector part
Extension cable (Option)	5 m, 10 m, 15 m, 20 m

(Note) Digital error under Counter (CEU5) is included. Besides, the whole accuracy after mounting on an equipment may be varied depending on the mounting condition and surroundings. As an equipment, calibration should be done by customer.

Standard Stroke

Bore size (mm)	Standard stroke (mm)		Range of manufacturable stroke*	
	Without rod boot	With rod boot	Without rod boot	With rod boot
40	25 to 850	25 to 700	Up to 1200	Up to 950
50	25 to 800	25 to 650	Up to 1150	Up to 900
63	25 to 800	25 to 650	Up to 1150	Up to 900
80	25 to 750	25 to 600	Up to 1100	Up to 900
100	25 to 750	25 to 600	Up to 1100	Up to 850

* Strokes longer than the standard stroke are made-to-order products.

* Applicable strokes should be confirmed according to the usage. For details, refer to "CA2 Series" in the Air Cylinders Model Selection on the **Web Catalog**.

Weight

Bore size (mm)		40	50	63	80	100
Basic weight	Basic type	2.18	3.39	5.29	8.66	12.09
	Foot type	2.37	3.61	5.63	9.33	13.08
	Flange type	2.55	3.84	6.08	10.11	14.01
	Single clevis type	2.41	3.73	5.92	9.77	13.87
	Double clevis type	2.45	3.82	6.08	10.06	14.39
	Trunnion type	3.63	3.92	6.18	10.36	14.49
Additional weight per each 50 mm of stroke	Aluminum tube	0.22	0.28	0.37	0.52	0.65
	Mounting bracket					
Accessory bracket	Single knuckle	0.23	0.26	0.26	0.60	0.83
	Double knuckle	0.32	0.38	0.38	0.73	1.08
	Knuckle pin	0.05	0.05	0.05	0.14	0.19

Calculation example: **CE2L40-100**

• Basic weight.....2.37 (Foot type, ø40)

• Additional weight.....0.22/50 stroke

• Cylinder stroke.....100 stroke

2.37 + 0.22 x 100/50 = 2.81 kg

Accessories

Mounting		Basic	Axial foot	Rod flange	Head flange	Single clevis	Double clevis	Center trunnion
Standard	Rod end nut	●	●	●	●	●	●	●
	Clevis pin	—	—	—	—	—	●	—
Option	Single knuckle joint	●	●	●	●	●	●	●
	Double knuckle joint (with pin)	●	●	●	●	●	●	●
	With rod boot	●	●	●	●	●	●	●

* Refer to page 690 for dimensions and part numbers of the option. Refer to page 688 for dimensions of the rod boot.

Construction

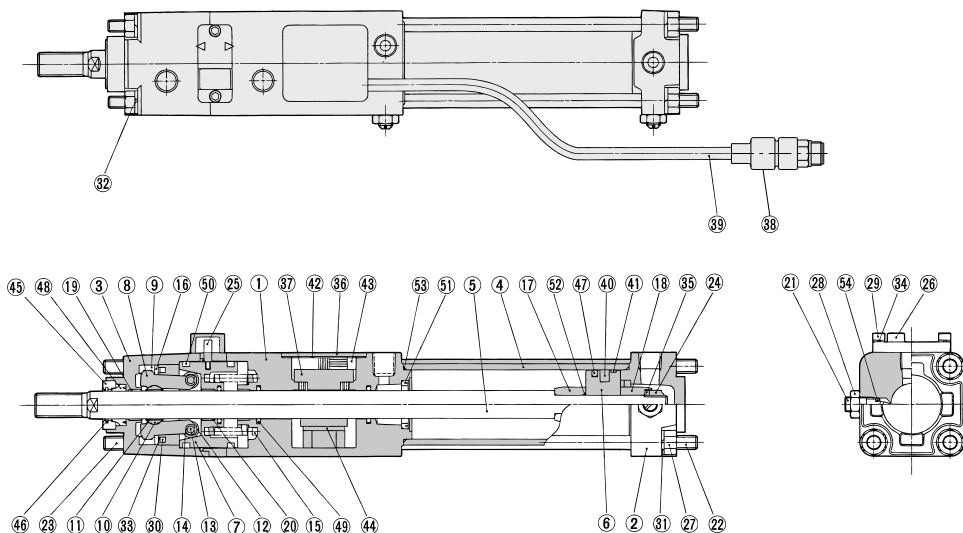

CEP1

CE1

CE2

ML2B

Component parts

No.	Description	Material	Note
1	Rod cover	Aluminum alloy	Black painted after hard anodized
2	Head cover	Aluminum alloy	Black painted
3	Cover	Aluminum alloy	Black painted after hard anodized
4	Cylinder tube	Aluminum alloy	Hard anodized
5	Piston rod	Free-cutting steel	Hard chrome plated
6	Piston	Aluminum alloy	Chromated
7	Brake piston	Carbon steel	Nitriding
8	Brake arm	Carbon steel	Nitriding
9	Brake arm holder	Carbon steel	Nitriding
10	Brake shoe holder	Carbon steel	Nitriding
11	Brake shoe	Special friction material	
12	Roller	Chromium molybdenum steel	Nitriding
13	Pin	Chrome bearing steel	Heat treated
14	Type E retaining ring	Stainless steel	JIS B 2805E
15	Brake spring	Steel wire	Dacrodized
16	Retaining plate	Rolled steel plate	Zinc chromated
17	Cushion ring A	Rolled steel	Electroless nickel plated
18	Cushion ring B	Rolled steel	Electroless nickel plated
19	Bushing	Lead-bronze casted	
20	Bushing	Lead-bronze casted	
21	Cushion valve	Rolled steel plate	Electroless nickel plated
22	Tie-rod	Carbon steel	Chromated
23	Unit holding tie-rod	Carbon steel	Chromated
24	Piston nut	Rolled steel plate	Zinc chromated
25	Non-rotating pin	Carbon steel	High frequency quenched
26	Pin guide	Carbon steel	Black painted after nitriding
27	Tie-rod nut	Carbon steel	Black zinc chromated

No.	Description	Material	Note
28	Lock nut	Carbon steel	Nickel plated
29	Hexagon socket head cap screw	Chromium molybdenum steel	Black zinc chromated
30	Hexagon socket head cap screw	Stainless steel	
31	Spring washer	Steel wire	Black zinc chromated
32	Spring washer	Steel wire	Black zinc chromated
33	Spring washer	Steel wire	Black zinc chromated
34	Spring washer	Steel wire	Black zinc chromated
35	Spring washer	Steel wire	Zinc chromated
36	Sensor cover	Carbon steel	
37	Detection head assembly	—	
38	Connector	—	
39	Cable	—	
40	Rubber magnet	NBR	
41	Wear ring	Resin	
42	Gasket	NBR	
43	Bushing	NBR	
44	Amp cushion	NBR	
45	Seal retainer	Aluminum alloy	
46	Coil scraper	Phosphor bronze	
47	Piston seal	NBR	
48	Rod seal A	NBR	
49	Rod seal B	NBR	
50	Brake piston seal	NBR	
51	Cushion seal	NBR	
52	Piston gasket	NBR	
53	Cylinder tube gasket	NBR	
54	Cushion valve seal	NBR	

D-□

-X□

CE2 Series



Dimensions: $\varnothing 40$ to $\varnothing 100$

Basic type

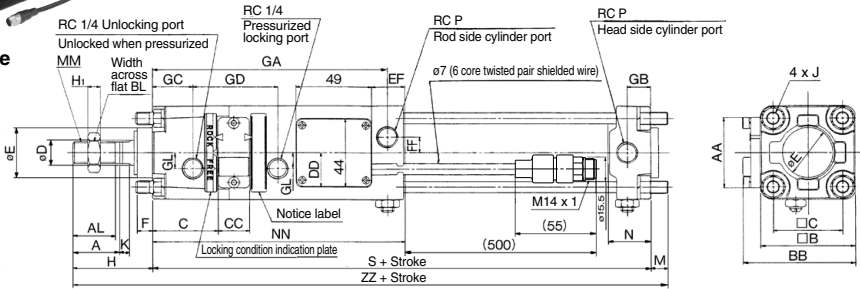

With rod boot

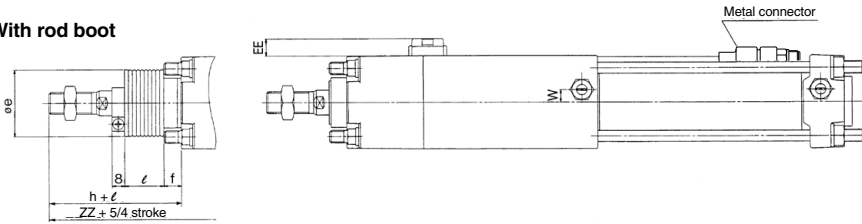

Bore size (mm)	Stroke range																										
	Without rod boot	With rod boot	A	AA	AL	BB	BL	□B	C	CC	□C	DD	D	EF	EE	E	F	FF	GA	GB	GC	GD	GL	H ₁	J	K	M
40	25 to 850	25 to 700	30	45	27	71.5	22	60	42	20	44	22	16	21	11.5	32	10	10	150.5	15	26	54	10	8	M8 x 1.25	6	11
50	25 to 800	25 to 650	35	50	32	80.5	27	70	46	21	52	24	20	28.5	10.5	40	10	12	162.5	17	27	59	13	11	M8 x 1.25	9	11
63	25 to 800	25 to 650	35	60	32	98.5	27	85	48.5	23	64	24	20	28.5	13.5	40	10	15	174	17	26	67	18	11	M10 x 1.25	9	14
80	25 to 750	25 to 600	40	70	37	117.5	32	102	55	23	78	26.5	25	36	15.5	52	14	17	189	21	30	72	23	13	M12 x 1.75	11	17
100	25 to 750	25 to 600	40	80	37	131.5	41	116	56.5	25	92	35.5	30	36	15.5	52	14	19	198	21	31	76	25	16	M12 x 1.75	11	17

Bore size (mm)	MM	N	NN	P	S	W	Without rod boot		With rod boot				
							H	ZZ	e	f	h	ℓ	ZZ
40	M14 x 1.5	27	161.5	1/4	218.5	8	51	280.5	43	11.2	59		
50	M18 x 1.5	30	175.5	3/8	235.5	0	58	304.5	52	11.2	66	312.5	
63	M18 x 1.5	31	187	3/8	254	0	58	326	52	11.2	66	334	
80	M22 x 1.5	37	205	1/2	284	0	71	372	65	12.5	80	381	
100	M26 x 1.5	40	214	1/2	300	0	72	389	65	14	81	398	

Foot type

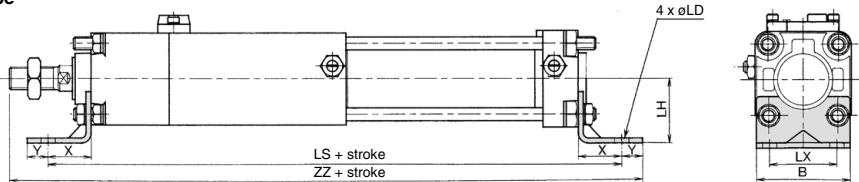

Bore size (mm)	B	LH	LS	LX	X	Y	ZZ	LD
40	58.5	40	272.5	42	27	13	309.5	9
50	68.5	45	289.5	50	27	13	333.5	9
63	83	50	322	59	34	16	362	11.5
80	100	65	372	76	44	16	415	13.5
100	114	75	386	92	43	17	432	13.5

Rod side flange type

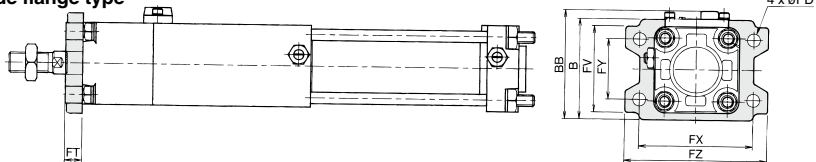

Head side flange type

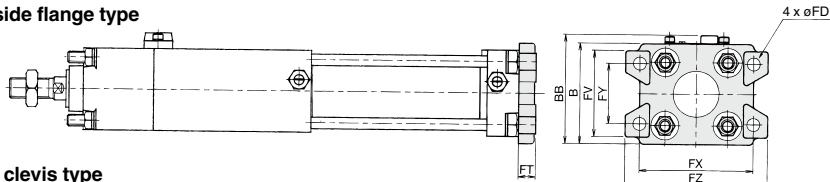

Single clevis type

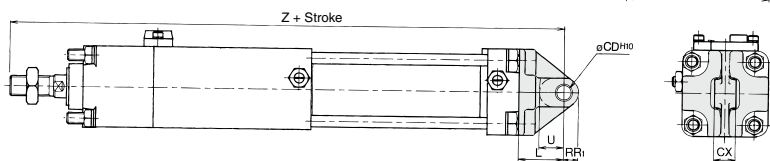

Double clevis type

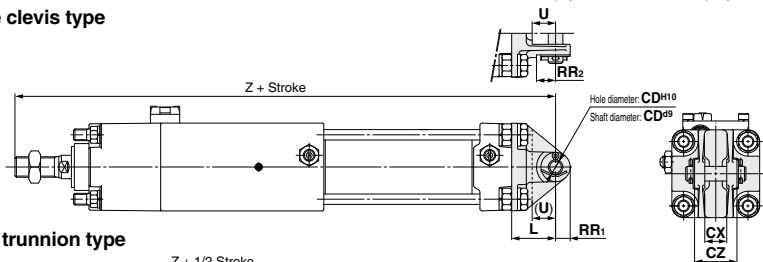

Center trunnion type

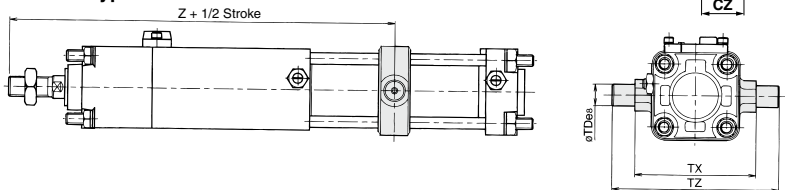

(mm)

Bore size (mm)	Rod side flange, Head side flange						Rod side flange						Single clevis, Double clevis					Single clevis			Double clevis			Center trunnion		
	FT	FV	FX	FY	FZ	FD	B	BB	CD ^{H10}	L	RR ₁	RR ₂	U	Z	CX	CX	CZ	TDø8	TX	TZ	Z					
40	12	60	80	42	100	9	71	77	10 ^{+0.058} / ₀	30	10	16	16	299.5	15 ^{+0.3} / _{-0.3}	15 ^{+0.3} / _{-0.3}	29.5	15 ^{-0.032} / _{-0.059}	85	117	227.5					
50	12	70	90	50	110	9	81	86	12 ^{+0.070} / ₀	35	12	19	19	328.5	18 ^{-0.1} / _{-0.3}	18 ^{+0.3} / _{-0.1}	38	15 ^{-0.032} / _{-0.059}	95	127	248.5					
63	15	86	105	59	130	11.5	101	107	16 ^{+0.070} / ₀	40	16	23	23	352	25 ^{+0.1} / _{-0.3}	25 ^{+0.3} / _{-0.1}	49	18 ^{-0.032} / _{-0.059}	110	148	263					
80	18	102	130	76	160	13.5	119	126	20 ^{+0.084} / ₀	48	20	28	28	403	31.5 ^{+0.1} / _{-0.3}	31.5 ^{+0.3} / _{-0.1}	61	25 ^{-0.040} / _{-0.073}	140	192	297					
100	18	116	150	92	180	13.5	133	140	25 ^{+0.084} / ₀	58	25	23.5	36	430	35.5 ^{-0.1} / _{-0.3}	35.5 ^{+0.3} / _{-0.1}	64	25 ^{-0.040} / _{-0.073}	162	214	309					

Mounting Bracket Part No.

Bore size (mm)	40	50	63	80	100
Axial foot *	CA2-L04	CA2-L05	CA2-L06	CA2-L08	CA2-L10
Flange	CA2-F04	CA2-F05	CA2-F06	CA2-F08	CA2-F10
Single clevis	CA2-C04	CA2-C05	CA2-C06	CA2-C08	CA2-C10
Double clevis **	CA2-D04	CA2-D05	CA2-D06	CA2-D08	CA2-D10

* When axial foot brackets are used, order two pieces per cylinder.

** A clevis pin, flat washers and split pins are shipped together with double clevis.

CE2 Series

Allowable Kinetic Energy

Operate the stroke reading cylinder with brake within the proper allowable kinetic energy. It must not be operated out of the allowable range, which is shown in the graph on the right. All sizes must be operated within this range. (Supply pressure 0.5 MPa)

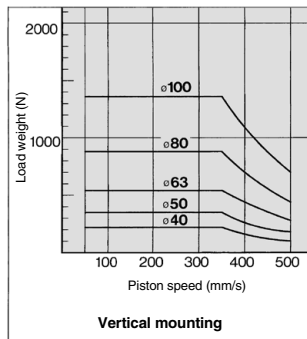
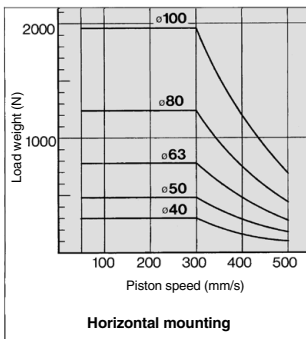

Dimensions of Accessories

Y Type Double Knuckle Joint

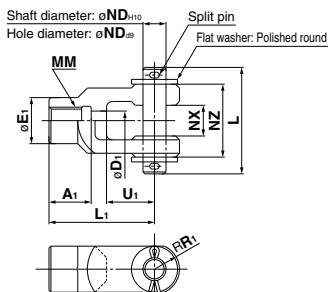

Material: Cast iron														(mm)	
Part no.	Applicable bore size	A ₁	E ₁	D ₁	L ₁	MM	R ₁	U ₁	ND	NX	NZ	L	Split pin size	Flat washer size	
Y-04D	40	22	24	10	55	M14 x 1.5	13	25	12	16 ^{+0.3} / _{+0.1}	38	55.5	ø3 x 18 L	Polished round 12	
Y-05D	50, 63	27	28	14	60	M18 x 1.5	15	27	12	16 ^{+0.3} / _{+0.1}	38	55.5	ø3 x 18 L	Polished round 12	
Y-08D	80	37	36	18	71	M22 x 1.5	19	28	18	28 ^{+0.3} / _{+0.1}	55	76.5	ø4 x 25 L	Polished round 18	
Y-10D	100	37	40	21	83	M26 x 1.5	21	38	20	30 ^{+0.3} / _{+0.1}	61	83	ø4 x 30 L	Polished round 20	

* A knuckle pin, split pins and flat washers are included.

Clevis Pin/Knuckle Pin

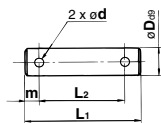

Material: Carbon steel										(mm)	
Part no.	Applicable bore size		Dd ₉	L ₁	L ₂	m	d	Included split pin	Included flat washer		
	Clevis	Knuckle									
CDP-2A	40	—	10 ^{-0.040} / _{-0.076}	46	38	4	3	ø3 x 18 L	Polished round 10		
CDP-3A	50	40, 50, 63	12 ^{-0.050} / _{-0.093}	55.5	47.5	4	3	ø3 x 18 L	Polished round 12		
CDP-4A	63	—	16 ^{-0.050} / _{-0.093}	71	61	5	4	ø4 x 25 L	Polished round 16		
CDP-5A	—	80	18 ^{-0.050} / _{-0.093}	76.5	66.5	5	4	ø4 x 25 L	Polished round 18		
CDP-6A	80	100	20 ^{-0.065} / _{-0.117}	83	73	5	4	ø4 x 30 L	Polished round 20		
CDP-7A	100	—	25 ^{-0.065} / _{-0.117}	88	78	5	4	ø4 x 36 L	Polished round 24		

* Split pins and flat washers are included.

I Type Single Knuckle Joint

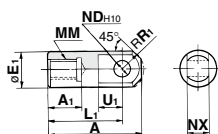

Material: Free cutting sulfur steel												(mm)	
Part no.	Applicable bore size	A	A ₁	E ₁	L ₁	MM	R ₁	U ₁	ND _{H10}	NX			
I-04A	40	69	22	24	55	M14 x 1.5	15.5	20	12 ^{+0.070} / _{-0.3}	16 ^{-0.1} / _{-0.3}			
I-05A	50, 63	74	27	28	60	M18 x 1.5	15.5	20	12 ^{+0.070} / _{-0.3}	16 ^{-0.1} / _{-0.3}			
I-08A	80	91	37	36	71	M22 x 1.5	22.5	26	18 ^{+0.070} / _{-0.3}	28 ^{-0.1} / _{-0.3}			
I-10A	100	105	37	40	83	M26 x 1.5	24.5	28	20 ^{+0.084} / _{-0.3}	30 ^{-0.1} / _{-0.3}			

Rod End Nut (Standard)

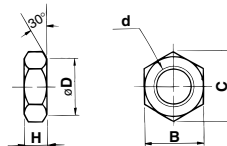

Material: Rolled steel						(mm)			
Part no.	Applicable bore size	d	H	B	C	D			
NT-04	40	M14 x 1.5	8	22	25.4	21			
NT-05	50, 63	M18 x 1.5	11	27	31.2	26			
NT-08	80	M22 x 1.5	13	32	37.0	31			
NT-10	100	M26 x 1.5	16	41	47.3	39			

CEP1

CE1

CE2

ML2B

D-□

-X□

Auto Switch Mounting 1

Auto Switch Proper Mounting Position (Detection at Stroke End) and Its Mounting Height

<Band mounting>

D-B5□/B64/B59W

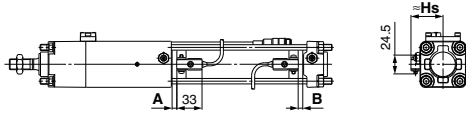

D-A3□
D-G39/K39

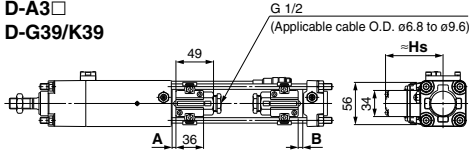

D-G5□/K59
D-G5□W/K59W
D-G5BA
D-G59F/G5NT

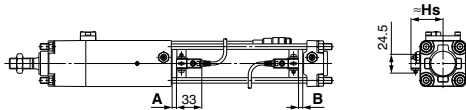

D-A44

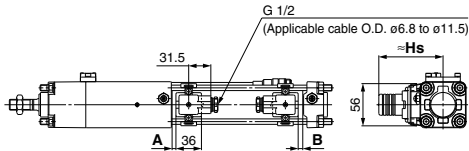

<Tie-rod mounting>

D-A9□/A9□V D-Z7□/Z80
D-M9□/M9□V D-Y59□/Y69□/Y7P/Y7PV
D-M9□W/M9□WV D-Y7□W/Y7□WV
D-M9□A/M9□AV D-Y7BA

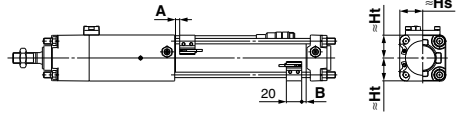

D-A5□/A6□
D-A59W

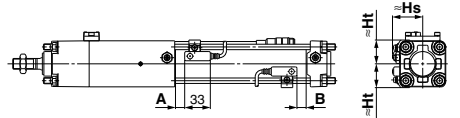

D-A3□C
D-G39C/K39C

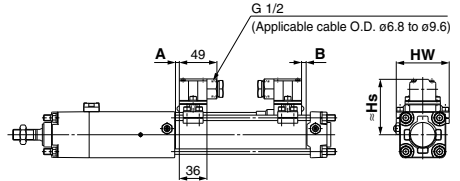

D-F5□/J59
D-F5NT
D-F5□W/J59W
D-F5BA/F59F

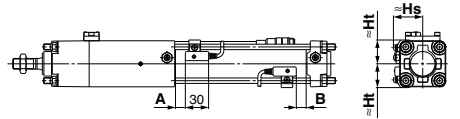

D-A44C

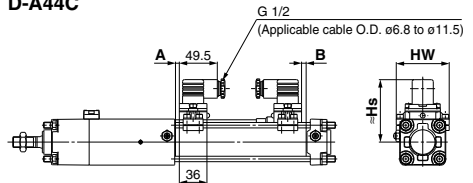

Auto Switch Proper Mounting Position (Detection at Stroke End) and Its Mounting Height

Auto Switch Proper Mounting Position

(mm)

Auto switch model Bore size (mm)	D-A9□ D-A9□V		D-M9□ D-M9□V D-M9□W D-M9□WV D-M9□A D-M9□AV		D-B59W D-Z7□ D-Z80 D-Y59□ D-Y69□ D-Y7P D-Y7PV D-Y7□WV D-Y7BA		D-A5□ D-A6□ D-A3□ D-A3□C D-A44 D-A44C D-G39 D-G39C D-K39 D-K39C		D-B5□ D-B64		D-F5□ D-J59 D-F59F D-F5□W D-J59W D-F5BA		D-G5□ D-K59 D-G5NT D-G5□W D-K59W D-G5BA D-G59F		D-A59W		D-F5NT	
	A	B	A	B	A	B	A	B	A	B	A	B	A	B	A	B	A	B
40	6	4	10	8	3.5	1.5	0	0	0.5	0	6.5	4.5	2	0	4	2	11.5	9.5
50	—	—	10	8	3.5	1.5	0	0	0.5	0	6.5	4.5	2	0	4	2	11.5	9.5
63	8.5	7.5	12.5	11.5	6	5	2.5	1.5	3	2	9	8	4.5	3.5	6.5	5.5	14	13
80	12	10	16	14	9.5	7.5	6	4	6.5	4.5	12.5	8	6	10	8	17.5	15.5	
100	13.5	12.5	17.5	16.5	11	10	7.5	6.5	8	7	14	13	9.5	8.5	11.5	10.5	19	18

* D-A9□ and D-A9□V cannot be mounted on ø50.
Note) Adjust the auto switch after confirming the operating conditions in the actual setting.

CEP1

CE1

CE2

ML2B

Auto Switch Mounting Height

(mm)

Auto switch model Bore size (mm)	D-A9□ D-M9□ D-M9□W D-M9□A		D-A9□V		D-M9□V D-M9□WV D-M9□AV		D-Z7□ D-Z80 D-Y59□ D-Y7P D-Y7BA D-Y7□W		D-Y69□ D-Y7PV D-Y7□WV		D-B5□ D-B64 D-B59W D-G5□ D-K59 D-G5NT D-G5□W D-K59W D-G5BA D-G59F		D-A3□ D-G39 D-K39		D-A44		D-A5□ D-A6□ D-A59W		D-F5□ D-J59 D-F5□W D-J59W D-F5BA D-F59F D-F5NT		D-A3□C D-G39C D-K39C		D-A44C	
	Hs	Ht	Hs	Ht	Hs	Ht	Hs	Ht	Hs	Ht	Hs	Hs	Hs	Ht	Hs	Ht	Hs	Hw	Hs	Hw	Hs	Hw		
40	30	30	32	30	35	30	30	30	30	30.5	30	38	72.5	80.5	40	31	38.5	31	73	69	81	69		
50	34	34	36.5	34	39	34	34	34	35	34	43.5	78	86	43.5	35	42.5	35	78.5	77	86.5	77			
63	41	41	43.5	41	46	41	41	41	42.5	41	50.5	85	93	49	42	48	42	85.5	91	93.5	91			
80	49.5	49	51.5	49	54	49	49.5	48.5	51	48.5	59	93.5	101.5	55.5	50	54	50	94	107	102	107			
100	57	56	59.5	56	62.5	56	58.5	56	59	56	69.5	104	112	63	57.5	62	57.5	104	121	112	121			

* D-A9□ and D-A9□V cannot be mounted on ø50.

D-□

-X□

Auto Switch Mounting 2

Minimum Auto Switch Mounting Stroke

n: No. of auto switches (mm)

Auto switch model	No. of auto switch mounted	Mounting brackets other than center trunnion	Center trunnion				
			ø40	ø50	ø63	ø80	ø100
D-A9□	2 (Different surfaces, Same surface) 1	15	75	—	80	85	90
	n	$15 + 40 \frac{(n-2)}{2}$ (n = 2, 4, 6, 8 ...) Note 1)	$75 + 40 \frac{(n-4)}{2}$ (n = 4, 8, 12, 16 ...) Note 2)		$80 + 40 \frac{(n-4)}{2}$ (n = 4, 8, 12, 16 ...) Note 2)	$85 + 40 \frac{(n-4)}{2}$ (n = 4, 8, 12, 16 ...) Note 2)	$90 + 40 \frac{(n-4)}{2}$ (n = 4, 8, 12, 16 ...) Note 2)
D-A9□V	2 (Different surfaces, Same surface) 1	10	50	—	55	60	65
	n	$10 + 30 \frac{(n-2)}{2}$ (n = 2, 4, 6, 8 ...) Note 1)	$50 + 30 \frac{(n-4)}{2}$ (n = 4, 8, 12, 16 ...) Note 2)		$55 + 30 \frac{(n-4)}{2}$ (n = 4, 8, 12, 16 ...) Note 2)	$60 + 30 \frac{(n-4)}{2}$ (n = 4, 8, 12, 16 ...) Note 2)	$65 + 30 \frac{(n-4)}{2}$ (n = 4, 8, 12, 16 ...) Note 2)
D-M9□ D-M9□W	2 (Different surfaces, Same surface) 1	15	80	85	90	95	
	n	$15 + 40 \frac{(n-2)}{2}$ (n = 2, 4, 6, 8 ...) Note 1)	$80 + 40 \frac{(n-4)}{2}$ (n = 4, 8, 12, 16 ...) Note 2)	$85 + 40 \frac{(n-4)}{2}$ (n = 4, 8, 12, 16 ...) Note 2)	$90 + 40 \frac{(n-4)}{2}$ (n = 4, 8, 12, 16 ...) Note 2)	$95 + 40 \frac{(n-4)}{2}$ (n = 4, 8, 12, 16 ...) Note 2)	
D-M9□V D-M9□WV	2 (Different surfaces, Same surface) 1	10	55	60	65	70	
	n	$10 + 30 \frac{(n-2)}{2}$ (n = 2, 4, 6, 8 ...) Note 1)	$55 + 30 \frac{(n-4)}{2}$ (n = 4, 8, 12, 16 ...) Note 2)	$60 + 30 \frac{(n-4)}{2}$ (n = 4, 8, 12, 16 ...) Note 2)	$65 + 30 \frac{(n-4)}{2}$ (n = 4, 8, 12, 16 ...) Note 2)	$70 + 30 \frac{(n-4)}{2}$ (n = 4, 8, 12, 16 ...) Note 2)	
D-M9□A	2 (Different surfaces, Same surface) 1	15	80	85	95	100	
	n	$15 + 40 \frac{(n-2)}{2}$ (n = 2, 4, 6, 8 ...) Note 1)	$80 + 40 \frac{(n-4)}{2}$ (n = 4, 8, 12, 16 ...) Note 2)	$85 + 40 \frac{(n-4)}{2}$ (n = 4, 8, 12, 16 ...) Note 2)	$95 + 40 \frac{(n-4)}{2}$ (n = 4, 8, 12, 16 ...) Note 2)	$100 + 40 \frac{(n-4)}{2}$ (n = 4, 8, 12, 16 ...) Note 2)	
D-M9□AV	2 (Different surfaces, Same surface) 1	10	60	65	70	75	
	n	$10 + 30 \frac{(n-2)}{2}$ (n = 2, 4, 6, 8 ...) Note 1)	$60 + 30 \frac{(n-4)}{2}$ (n = 4, 8, 12, 16 ...) Note 2)	$65 + 30 \frac{(n-4)}{2}$ (n = 4, 8, 12, 16 ...) Note 2)	$70 + 30 \frac{(n-4)}{2}$ (n = 4, 8, 12, 16 ...) Note 2)	$75 + 30 \frac{(n-4)}{2}$ (n = 4, 8, 12, 16 ...) Note 2)	
D-A5□/A6 D-F5□/J59 D-F5□W/J59W D-F5BA/F59F	2 (Different surfaces, Same surface) 1	15	90	100	110	120	
	n (Same surface)	$15 + 55 \frac{(n-2)}{2}$ (n = 2, 4, 6, 8 ...) Note 1)	$90 + 55 \frac{(n-4)}{2}$ (n = 4, 8, 12, 16 ...) Note 2)	$100 + 55 \frac{(n-4)}{2}$ (n = 4, 8, 12, 16 ...) Note 2)	$110 + 55 \frac{(n-4)}{2}$ (n = 4, 8, 12, 16 ...) Note 2)	$120 + 55 \frac{(n-4)}{2}$ (n = 4, 8, 12, 16 ...) Note 2)	
D-A59W	2 (Different surfaces, Same surface)	20	90	100	110	120	
	n (Same surface)	$20 + 55 \frac{(n-2)}{2}$ (n = 2, 4, 6, 8 ...) Note 1)	$90 + 55 \frac{(n-4)}{2}$ (n = 4, 8, 12, 16 ...) Note 2)	$100 + 55 \frac{(n-4)}{2}$ (n = 4, 8, 12, 16 ...) Note 2)	$110 + 55 \frac{(n-4)}{2}$ (n = 4, 8, 12, 16 ...) Note 2)	$120 + 55 \frac{(n-4)}{2}$ (n = 4, 8, 12, 16 ...) Note 2)	
	1	15	90	100	110	120	
D-F5NT	2 (Different surfaces, Same surface) 1	25	110	120	130	140	
	n (Same surface)	$25 + 55 \frac{(n-2)}{2}$ (n = 2, 4, 6, 8 ...) Note 1)	$110 + 55 \frac{(n-4)}{2}$ (n = 4, 8, 12, 16 ...) Note 2)	$120 + 55 \frac{(n-4)}{2}$ (n = 4, 8, 12, 16 ...) Note 2)	$130 + 55 \frac{(n-4)}{2}$ (n = 4, 8, 12, 16 ...) Note 2)	$140 + 55 \frac{(n-4)}{2}$ (n = 4, 8, 12, 16 ...) Note 2)	
D-B5□/B64 D-G5□/K59 D-G5□W D-K59W D-G5BA D-G59F D-G5NT	2 (Different surfaces)	15	90	100	110	110	
	(Same surface)	75					
	n	(Different surfaces)	$15 + 50 \frac{(n-2)}{2}$ (n = 2, 4, 6, 8, ...) Note 1)	$90 + 50 \frac{(n-4)}{2}$ (n = 4, 8, 12, 16, ...) Note 2)	$100 + 50 \frac{(n-4)}{2}$ (n = 4, 8, 12, 16, ...) Note 2)	$110 + 50 \frac{(n-4)}{2}$ (n = 4, 8, 12, 16, ...) Note 2)	
		(Same surface)	$75 + 50(n-2)$ (n = 2, 3, 4, ...)	$90 + 50(n-2)$ (n = 2, 4, 6, 8, ...) Note 1)	$100 + 50(n-2)$ (n = 2, 4, 6, 8, ...) Note 1)	$110 + 50(n-2)$ (n = 2, 4, 6, 8, ...) Note 1)	
		1	10	90	100	110	
D-B59W	2 (Different surfaces)	20	90	100	110	110	
	(Same surface)	75					
	n	(Different surfaces)	$20 + 50 \frac{(n-2)}{2}$ (n = 2, 4, 6, 8, ...) Note 1)	$90 + 50 \frac{(n-4)}{2}$ (n = 4, 8, 12, 16, ...) Note 2)	$100 + 50 \frac{(n-4)}{2}$ (n = 4, 8, 12, 16, ...) Note 2)	$110 + 50 \frac{(n-4)}{2}$ (n = 4, 8, 12, 16, ...) Note 2)	
		(Same surface)	$75 + 50(n-2)$ (n = 2, 3, 4, ...)	$90 + 50(n-2)$ (n = 2, 4, 6, 8, ...) Note 1)	$100 + 50(n-2)$ (n = 2, 4, 6, 8, ...) Note 1)	$110 + 50(n-2)$ (n = 2, 4, 6, 8, ...) Note 1)	
1	15	90	100	110			

Note 1) When "n" is an odd number, an even number that is one larger than this odd number is used for the calculation.

Note 2) When "n" is an odd number, a multiple of 4 that is larger than this odd number is used for the calculation.

Minimum Auto Switch Mounting Stroke

n: No. of auto switches (mm)

Auto switch model	No. of auto switch mounted	Mounting brackets other than center trunnion	Center trunnion				
			ø40	ø50	ø63	ø80	ø100
D-A3□ D-G39 D-K39	2	(Different surfaces)	35	75	80	90	
		(Same surface)	100	100	100	100	
	n	(Different surfaces)	$35 + 30(n-2)$ (n = 2, 3, 4, ...)	$75 + 30(n-2)$ (n = 2, 4, 6, 8, ...) Note 1)	$80 + 30(n-2)$ (n = 2, 4, 6, 8, ...) Note 1)	$90 + 30(n-2)$ (n = 2, 4, 6, 8, ...) Note 1)	
		(Same surface)	$100 + 100(n-2)$ (n = 2, 3, 4, ...)	$100 + 100(n-2)$ (n = 2, 4, 6, 8, ...) Note 1)			
	1	10	75	80	90		
D-A44	2	(Different surfaces)	35	75	80	90	
		(Same surface)	55				
	n	(Different surfaces)	$35 + 30(n-2)$ (n = 2, 3, 4, ...)	$75 + 30(n-2)$ (n = 2, 4, 6, 8, ...) Note 1)	$80 + 30(n-2)$ (n = 2, 4, 6, 8, ...) Note 1)	$90 + 30(n-2)$ (n = 2, 4, 6, 8, ...) Note 1)	
		(Same surface)	$55 + 50(n-2)$ (n = 2, 3, 4, ...)	$75 + 50(n-2)$ (n = 2, 4, 6, 8, ...) Note 1)	$80 + 50(n-2)$ (n = 2, 4, 6, 8, ...) Note 1)	$90 + 50(n-2)$ (n = 2, 4, 6, 8, ...) Note 1)	
	1	10	75	80	90		
D-A3□C D-G39C D-K39C	2	(Different surfaces)	20	75	80	90	
		(Same surface)	100	100	100	100	
	n	(Different surfaces)	$20 + 35(n-2)$ (n = 2, 3, 4, ...)	$75 + 35(n-2)$ (n = 2, 4, 6, 8, ...) Note 1)	$80 + 35(n-2)$ (n = 2, 4, 6, 8, ...) Note 1)	$90 + 35(n-2)$ (n = 2, 4, 6, 8, ...) Note 1)	
		(Same surface)	$100 + 100(n-2)$ (n = 2, 3, 4, 5-...)	$100 + 100(n-2)$ (n = 2, 4, 6, 8, ...) Note 1)			
	1	10	75	80	90		
D-A44C	2	(Different surfaces)	20	75	80	90	
		(Same surface)	55	75	80	90	
	n	(Different surfaces)	$20 + 35(n-2)$ (n = 2, 3, 4, ...)	$75 + 35(n-2)$ (n = 2, 4, 6, 8, ...) Note 1)	$80 + 35(n-2)$ (n = 2, 4, 6, 8, ...) Note 1)	$90 + 35(n-2)$ (n = 2, 4, 6, 8, ...) Note 1)	
		(Same surface)	$55 + 50(n-2)$ (n = 2, 3, 4, ...)	$75 + 50(n-2)$ (n = 2, 4, 6, 8, ...) Note 1)	$80 + 50(n-2)$ (n = 2, 4, 6, 8, ...) Note 1)	$90 + 50(n-2)$ (n = 2, 4, 6, 8, ...) Note 1)	
	1	10	75	80	90		
D-Z7□/Z80 D-Y59□/Y7P D-Y7□W	2 (Different surfaces, Same surface) 1	15	80	85	90	95	105
	n	$15 + 40 \frac{(n-2)}{2}$ (n = 2, 4, 6, 8-...) Note 1)	$80 + 40 \frac{(n-4)}{2}$ (n = 4, 8, 12, 16-...) Note 2)	$85 + 40 \frac{(n-4)}{2}$ (n = 4, 8, 12, 16-...) Note 2)	$90 + 40 \frac{(n-4)}{2}$ (n = 4, 8, 12, 16-...) Note 2)	$95 + 40 \frac{(n-4)}{2}$ (n = 4, 8, 12, 16-...) Note 2)	$105 + 40 \frac{(n-4)}{2}$ (n = 4, 8, 12, 16-...) Note 2)
D-Y69□/Y7PV D-Y7□WV	2 (Different surfaces, Same surface) 1	10	65	75	80	90	
	n	$10 + 30 \frac{(n-2)}{2}$ (n = 2, 4, 6, 8-...) Note 1)	$65 + 30 \frac{(n-4)}{2}$ (n = 4, 8, 12, 16-...) Note 2)	$75 + 30 \frac{(n-4)}{2}$ (n = 4, 8, 12, 16-...) Note 2)	$80 + 30 \frac{(n-4)}{2}$ (n = 4, 8, 12, 16-...) Note 2)	$90 + 30 \frac{(n-4)}{2}$ (n = 4, 8, 12, 16-...) Note 2)	
D-Y7BA	2 (Different surfaces, Same surface) 1	20	95	100	105	110	
	n	$20 + 45 \frac{(n-2)}{2}$ (n = 2, 4, 6, 8-...) Note 1)	$95 + 45 \frac{(n-4)}{2}$ (n = 4, 8, 12, 16-...) Note 2)	$100 + 45 \frac{(n-4)}{2}$ (n = 4, 8, 12, 16-...) Note 2)	$105 + 45 \frac{(n-4)}{2}$ (n = 4, 8, 12, 16-...) Note 2)	$110 + 45 \frac{(n-4)}{2}$ (n = 4, 8, 12, 16-...) Note 2)	

Note 1) When "n" is an odd number, an even number that is one larger than this odd number is used for the calculation.

Note 2) When "n" is an odd number, a multiple of 4 that is larger than this odd number is used for the calculation.

CEP1

CE1

CE2

ML2B

D-□

X-□

Operating Range

Auto switch model	Bore size (mm)				
	40	50	63	80	100
D-A9□/A9□V	7	—	9	9	9
D-M9□/M9□V D-M9□W/M9□WV D-M9□A/M9□AV	5	5	5.5	6	6.5
D-Z7□/Z80	8	7	9	9.5	10.5
D-A3□/A44 D-A3□C/A44C	9	10	11	11	11
D-A5□/A6□ D-B5□/B64					
D-A59W	13	13	14	14	15
D-B59W	14	14	17	16	18

Auto switch model	Bore size (mm)				
	40	50	63	80	100
D-Y59□/Y69□ D-Y7P/Y7□V D-Y7□W/Y7□WV D-Y7BA	8	7	5.5	6.5	6.5
D-F5□/J59/F5□W D-J59W/F5BA D-F5NT D-F59F	4	4	4.5	4.5	4.5
D-G5□/K59/G5□W D-K59W/G5BA D-G5NT/G59F	5	6	6.5	6.5	7
D-G39/K39 D-G39C/K39C	9	9	10	10	11

* D-A9□ and D-A9□V cannot be mounted on ø50.

* Since the operating range is provided as a guideline including hysteresis, it cannot be guaranteed (assuming approximately ±30% dispersion). It may vary substantially depending on an ambient environment.

Auto Switch Mounting Bracket: Part No.

<Tie-rod mounting>

Auto switch model	Bore size (mm)				
	40	50	63	80	100
D-A9□/A9□V D-M9□/M9□V D-M9□W/M9□WV D-M9□A/M9□AV	BA7-040	BA7-040	BA7-063	BA7-080	BA7-080
D-A5□/A6□ D-A59W D-F5□/J59 D-F5□W/J59W D-F59F/F5NT	BT-04	BT-04	BT-06	BT-08	BT-08
D-A3□C/A44C D-G39C/K39C	BA3-040	BA3-050	BA3-063	BA3-080	BA3-100
D-Z7□/Z80 D-Y59□/Y69□ D-Y7P/Y7PV D-Y7□W/Y7□WV D-Y7BA	BA4-040	BA4-040	BA4-063	BA4-080	BA4-080

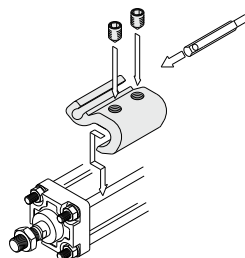

• Mounting example of D-A9□(V)/M9□(V)/M9□W(V)/M9□A(V)

<Band mounting>

Auto switch model	Bore size (mm)				
	40	50	63	80	100
D-A3□/A44 D-G39/K39	BD1-04M	BD1-05M	BD1-06M	BD1-08M	BD1-10M
D-B5□/B64 D-B59W D-G5□/K59 D-G5□W/K59W D-G59F D-G5NT	BA-04	BA-05	BA-06	BA-08	BA-10

Note 1) D-A9□ and D-A9□V cannot be mounted on ø50.

Note 2) Auto switch mounting brackets are included in D-A3□C/A44C/G39C/K39C.

Order them in accordance with the cylinder size as shown below.

(Example) ø40: D-A3□C-4, ø50: D-A3□C-5

ø63: D-A3□C-6, ø80: D-A3□C-8, ø100: D-A3□C-10

Order them with the part numbers above when the mounting brackets are required separately.

[Mounting screw set made of stainless steel]

The following set of mounting screws made of stainless steel (including nuts) is available. Use it in accordance with the operating environment.

(Please order the auto switch mounting bracket and band separately, since they are not included.)

BBA1: For D-A5/A6/F5/J5 types

BBA3: For D-B5/B6/G5/K5 types

D-F5BA/G5BA auto switches are set on the cylinder with the stainless steel screws above when shipped. When an auto switch is shipped independently, BBA1 or BBA3 is attached.

Note 3) Refer to pages 1047 and 1055 for the details of BBA1 and BBA3.

Note 4) When using M9□A(V)/Y7BA, do not use the steel set screws which is included with the auto switch mounting brackets above (BA7-□□□, BA4-□□□).

Order a stainless steel screw set (BBA1) separately, and select and use the M4 x 6L stainless steel set screws included in the BBA1.

Besides the models listed in How to Order, the following auto switches are applicable.
Refer to pages 941 to 1067 for detailed specifications.

Auto switch type	Part no.	Electrical entry (Fetching direction)	Features
Reed	D-A93V, A96V	Grommet (Perpendicular)	—
	D-A90V		Without indicator light
	D-A53, A56, B53, Z73, Z76	Grommet (In-line)	—
	D-A67, Z80		Without indicator light
Solid state	D-M9NV, M9PV, M9BV	Grommet (Perpendicular)	—
	D-Y69A, Y69B, Y7PV		Diagnostic indication (2-color indicator)
	D-M9NWV, M9PWV, M9BWW		
	D-Y7NWV, Y7PWV, Y7BWW	Grommet (In-line)	Water resistant (2-color indicator)
	D-M9NAV, M9PAV, M9BAV		—
	D-Y59A, Y59B, Y7P		Diagnostic indication (2-color indicator)
	D-F59, F5P, J59		
	D-Y7NW, Y7PW, Y7BW		Water resistant (2-color indicator)
	D-F59W, F5PW, J59W		
	D-F5BA, Y7BA		
	D-F5NT, G5NT		

* For solid state auto switches, auto switches with a pre-wired connector are also available. Refer to pages 1014 and 1015 for details.

* Normally closed (NC = b contact) solid state auto switches (D-M9□E(V)/Y7G/Y7H) are also available. Refer to pages 1592-1 and 961 for details.

CEP1

CE1

CE2

ML2B

D-□

-X□