

Air Saving Valve

Series **ASR**

Series **ASQ**

Pressure Valve

Flow Valve

40% reduction in air consumption

Cuts air consumption by operating the return stroke at a reduced pressure.

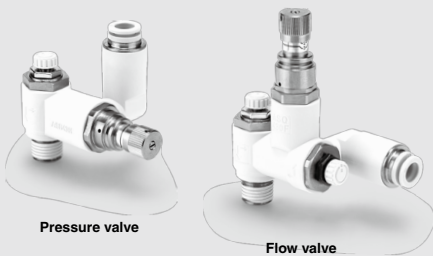
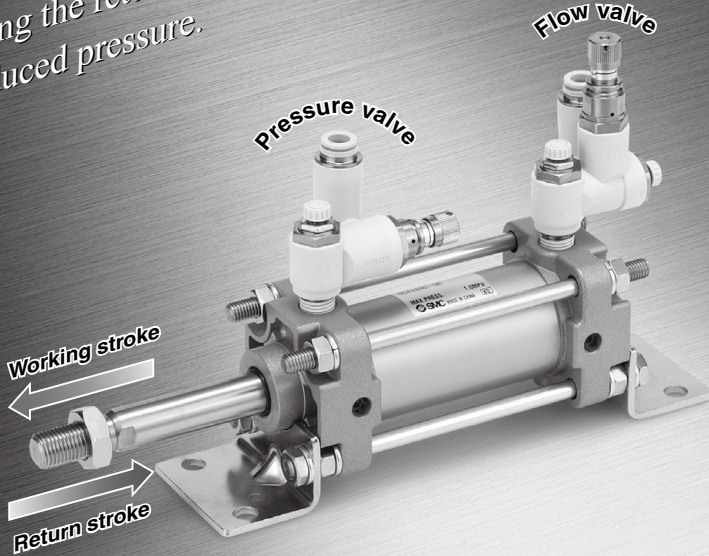
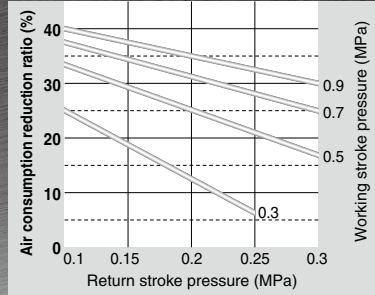

- AS
- TMH
- ASD
- AS
- AS-FE
KE
- AS-FG
- AS-FP
- AS-FM
- AS-D
AS-T
- ASP
- ASN
- AQ
- ASV
- AK
- VCHC
- ASS
- ASR
ASQ

Cuts air consumption by operating the return stroke at a reduced pressure.

Conventional valve

Working and return strokes operated at the same pressure

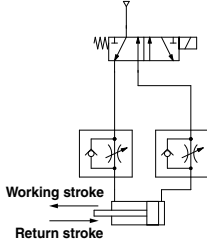

Air saving valve

Return stroke operated at a reduced pressure

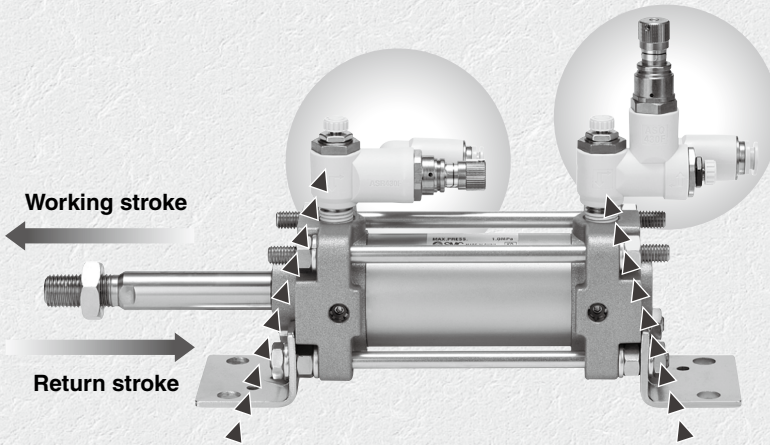
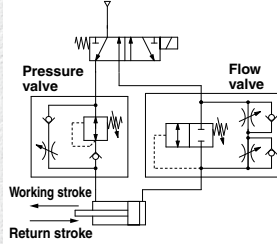

Pressure valve

Regulator with check valve
+
Speed controller



Series ASR

Flow valve

Quick supply and exhaust valve
+
Speed controller
(Meter-in, Meter-out)



Series ASQ

Smooth operation of working and return strokes possible.

Consistent speed control achieved by preventing jerky movement of working strokes.

Improved response time

Operation delay in a return stroke is reduced by the use of a quick supply and exhaust valve.

Delay in return operation

--- Cylinder operation by conventional 2 pressure control
 — Cylinder operation by air saving valve
 - - - Cylinder operation by speed controller

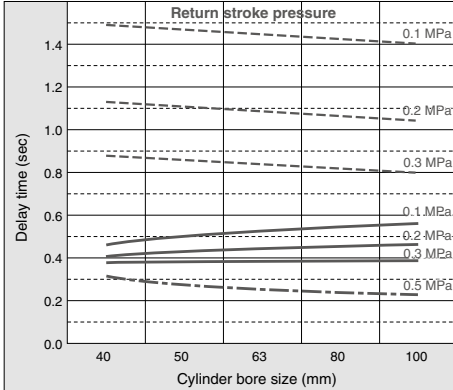

Cylinder speed: 200 mm/sec
 Cylinder stroke: 200 mm

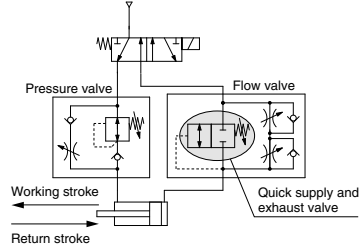

Cylinder operating pressure (MPa)	Air consumption reduction ratio (%)	
	Working stroke	Return stroke
0.5	0.5	0
	0.3	17
	0.2	25
	0.1	33

Easy piping

The body and One-touch fitting allow 360° rotation. The sealant on the male thread is standardized.

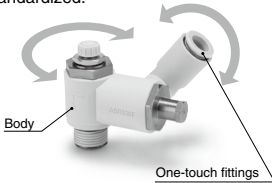

The set pressure can be either fixed or variable.

Fixed set pressure type
 (Fixed at 0.2 MPa)

Variable set pressure type
 (Variable between 0.1 and 0.3 MPa)

Graduated knob



A knob cap is attached to the variable set pressure type.

Other applications

Jerk prevention in vertical operation of the cylinder

Quick air charge at the end of stroke for press applications

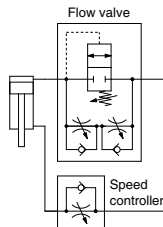
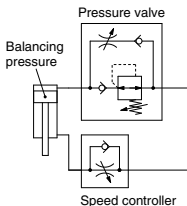

Series Variations

Model		Port size	Applicable tubing O.D. (mm)			
Pressure valve	Flow valve		6	8	10	12
ASR430F-02	ASQ430F-02	R1/4	●	●	●	
ASR530F-02	ASQ530F-02	R1/4	●	●	●	●
ASR530F-03	ASQ530F-03	R3/8	●	●	●	●
ASR630F-03	ASQ630F-03	R3/8			●	●
ASR630F-04	ASQ630F-04	R1/2			●	●

AS
 TMH
 ASD
 AS
 AS-FE
 KE
 AS-FG
 AS-FP
 AS-FM
 AS-D
 AS-T
 ASP
 ASN
 AQ
 ASV
 AK
 VCHC
 ASS
 ASR
 ASQ

Air Saving Valve Pressure Valve Flow Valve

Series ASR / Series ASQ

Pressure valve: Series ASR



Regulator with check valve and flow control valve integrated into a single construction

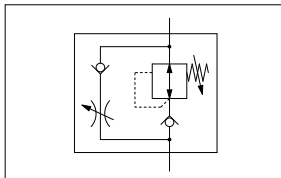

Flow valve: Series ASQ



Pilot valve and two-way flow control valve integrated into a single construction

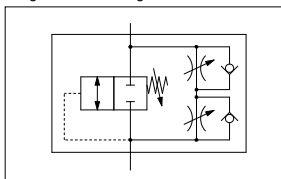

How to Order

ASR 4 3 0 F - 02 - 06 S - F20 -

Model

ASR	Pressure valve
ASQ	Flow valve

Body size

4	1/4 standard
5	3/8 standard
6	1/2 standard

Type

3	Universal
---	-----------

With One-touch fitting

With seal

Applicable tubing O.D.

06	6 mm
08	8 mm
10	10 mm
12	12 mm

Option

N11	Variable set pressure type (0.1 to 0.3 MPa)
F20	Fixed set pressure type (0.2 MPa)

Lock nut option

N11	Hexagon lock nut
J	Round lock nut

Port size

02	R1/4
03	R3/8
04	R1/2

Model

Model		Port size	Applicable tubing O.D. (mm)			
Pressure valve	Flow valve		6	8	10	12
ASR430F-02	ASQ430F-02	R1/4	●	●	●	
ASR530F-02	ASQ530F-02	R1/4	●	●	●	●
ASR530F-03	ASQ530F-03	R3/8	●	●	●	●
ASR630F-03	ASQ630F-03	R3/8			●	●
ASR630F-04	ASQ630F-04	R1/2			●	●

Specifications

Fluid	Air	
Proof pressure	1.5 MPa	
Maximum operating pressure	1.0 MPa	
Set pressure range	Variable	0.1 to 0.3 MPa
	Fixed (option)	0.2 MPa
Ambient and fluid temperature	-5 to 60°C (with no freezing)	
Applicable tubing material	Nylon, Soft nylon, Polyurethane	

AS
TMH
ASD
AS
AS-FE
KE
AS-FG
AS-FP
AS-FM
AS-D
AS-T
ASP
ASN
AQ
ASV
AK
VCHC
ASS
ASR
ASQ

Series ASR/Series ASQ

Effective Area

Pressure Valve: Series ASR

Type	Free flow		Controlled flow	
	Sonic conductance dm ³ /(s·bar)	Critical pressure ratio	Sonic conductance dm ³ /(s·bar)	Critical pressure ratio
ASR430F-02-06S(-F20)	1	0.2	1.1	0.25
ASR430F-02-08S(-F20)	1.1		1.2	
ASR430F-02-10S(-F20)	1.1		1.2	
ASR530F-02-06S(-F20)	1.3		1.5	
ASR530F-02-08S(-F20)	1.6		2.1	
ASR530F-02-10S(-F20)	1.7		2.4	
ASR530F-02-12S(-F20)	1.7		2.5	
ASR530F-03-06S(-F20)	1.3		1.5	
ASR530F-03-08S(-F20)	1.6		2.1	
ASR530F-03-10S(-F20)	1.7		2.4	
ASR530F-03-12S(-F20)	1.7		2.5	
ASR630F-03-10S(-F20)	2.8		3.2	
ASR630F-03-12S(-F20)	2.9		3.5	
ASR630F-04-10S(-F20)	2.8		3.2	
ASR630F-04-12S(-F20)	2.9		3.5	

Flow Valve: Series ASQ

Type	Meter-out		Meter-in	
	Sonic conductance dm ³ /(s·bar)	Critical pressure ratio	Sonic conductance dm ³ /(s·bar)	Critical pressure ratio
ASQ430F-02-06S(-F20)	0.7	0.2	0.9	0.25
ASQ430F-02-08S(-F20)	0.8		1	
ASQ430F-02-10S(-F20)	0.8		1	
ASQ530F-02-06S(-F20)	1.2		1.4	
ASQ530F-02-08S(-F20)	1.7		1.8	
ASQ530F-02-10S(-F20)	1.8		2	
ASQ530F-02-12S(-F20)	2		2.1	
ASQ530F-03-06S(-F20)	1.2		1.4	
ASQ530F-03-08S(-F20)	1.7		1.8	
ASQ530F-03-10S(-F20)	1.8		2	
ASQ530F-03-12S(-F20)	2		2.1	
ASQ630F-03-10S(-F20)	2.8		3.1	
ASQ630F-03-12S(-F20)	3		3.3	
ASQ630F-04-10S(-F20)	2.8		3.1	
ASQ630F-04-12S(-F20)	3		3.3	

Operating Principle

Working Stroke

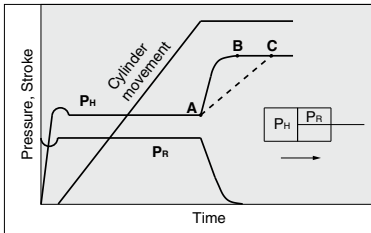

1. The cylinder starts smoothly because jerks are prevented by meter-in control.

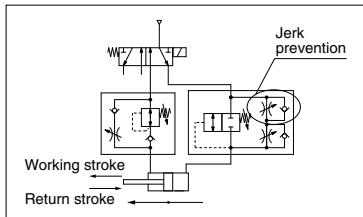

2. When the cylinder reaches the stroke end, the quick air charge by the flow valve rapidly increases the rear side pressure (PH) from A to B. If a speed controller is used instead of the flow valve, charging air will take more time as illustrated by line A-C, causing delay in the pressure rise.

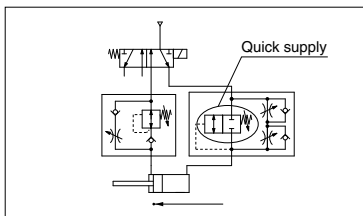

Return Stroke

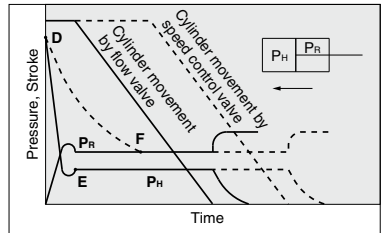

3. To prevent delay due to the pressure gap, air is rapidly exhausted to decrease the pressure from D to E, after which the piston moves at a constant speed. If a speed controller is used instead of the flow valve, exhausting air will take more time as illustrated by line D-F, resulting in longer stop time of the cylinder and a consequent time loss.

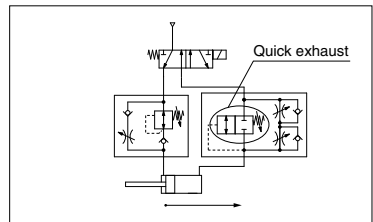

4. The cylinder operates at a low pressure required for a return.

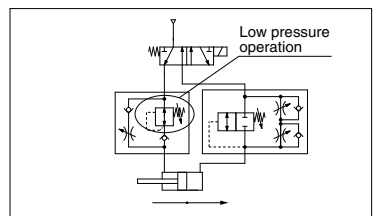

Flow Characteristics

(Note) The flow characteristics are representative values.

Pressure Valve: Series ASR (Inlet pressure: 0.5 MPa)

ASR430F

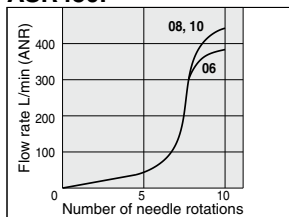

ASR530F

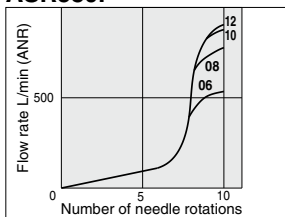

ASR630F

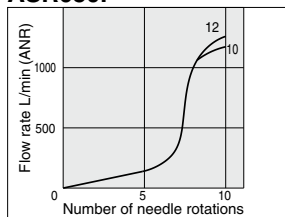

Flow Valve: Series ASQ

Meter-out Type (Inlet pressure: 0.3 MPa)

ASQ430F

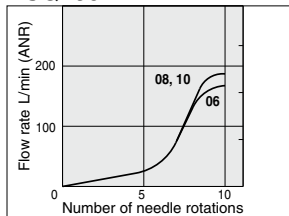

ASQ530F

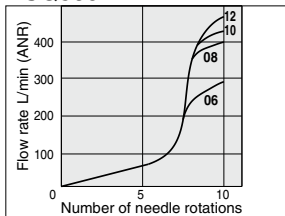

ASQ630F

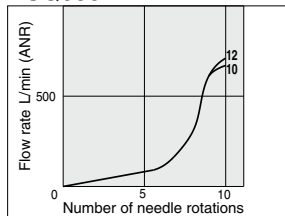

Meter-in Type (Inlet Pressure: 0.5 MPa)

ASQ430F

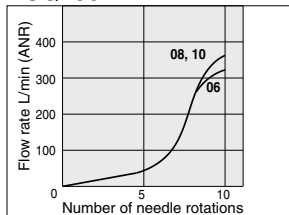

ASQ530F

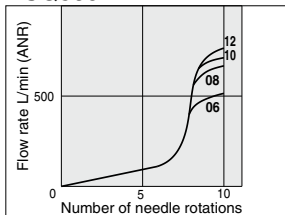

ASQ630F

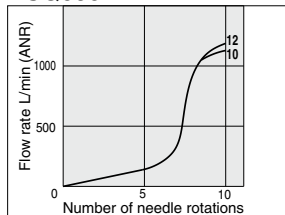

Pressure Characteristics (ASR)

ASR430F, ASR530F

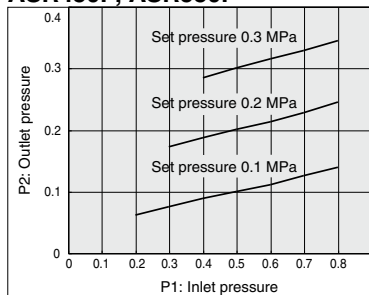

ASR630F

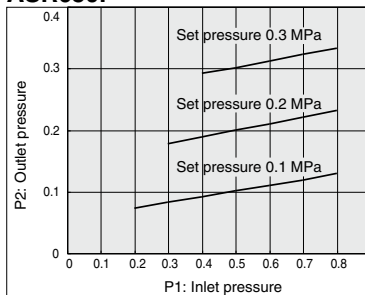

- AS
- TMH
- ASD
- AS
- AS-FE
- KE
- AS-FG
- AS-FP
- AS-FM
- AS-D
- AS-T
- ASP
- ASN
- AQ
- ASV
- AK
- VCHC
- ASS
- ASR
- ASQ

Series ASR/Series ASQ

Selection and Adjustment

Install a flow valve on the working side which requires the cylinder output and a pressure valve on the return side. The product cannot be used in cases where the same pressure is necessary for both working and return strokes. In such cases use a speed controller.

Horizontal mounting

Low pressure side: Pressure valve
High pressure side: Flow valve

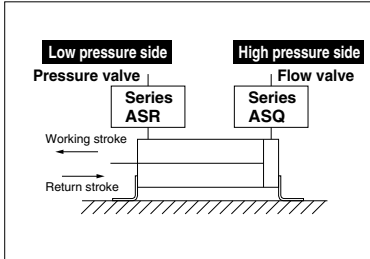

Refer to
Adjustment Procedure 1
for pressure and speed adjustment.

Vertical mounting

Low pressure side: Pressure valve
High pressure side: Flow valve

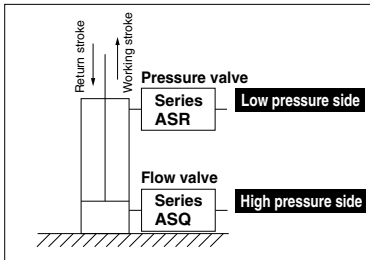

In case the load ratio is 50% or lower
at the set pressure of the flow valve:

Refer to
Adjustment Procedure 1
for pressure and speed adjustment.



If the load ratio at the set pressure of the flow valve exceeds
50%, install a dual speed controller (meter-in and meter out
control) on the high pressure side.

Low pressure side: Pressure valve
High pressure side: Dual speed controller

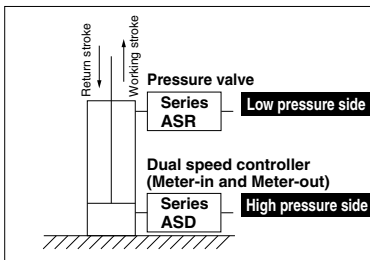

Refer to
Adjustment Procedure 2
for pressure and speed adjustment.

Adjustment Procedure 1

Pressure Adjustment

1. The fixed set pressure type (-F20) does not require adjustment because the pressure is fixed at 0.2 MPa for both the pressure valve and the flow valve.
2. The set pressures of the variable set pressure type pressure valve and flow valve are adjusted with knob (A) and knob (B) respectively. Turn the knob clockwise to increase the pressure and counterclockwise to decrease the pressure.
3. The graduations 1, 2 and 3 correspond to 0.1, 0.2 and 0.3 MPa respectively. Align the bottom end of the knob with the graduated line for adjustment.

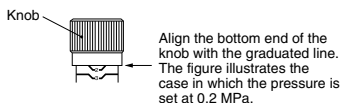

4. Set the same pressure for the pressure valve and the flow valve (0.2 MPa as the recommended value).
5. The inlet side should be supplied with a pressure which is higher than the set pressure by 0.1 MPa or more.
6. Cap the valve after adjustment.

Pressure Valve: Series ASR



Speed Control

1. The cylinder speed is adjusted with knobs (C), (D) and (E). First have all the knobs fully closed and then open them gradually for adjustment. Turn the knob clockwise to close (decrease the speed of the piston rod) and counterclockwise to open (increase the speed of the piston rod).
2. Speed adjustment for the working stroke
 The speed is adjusted with the pressure valve and the flow valve.
 Open knobs (C) and (E) gradually until the required speed is achieved. Make sure that knobs (C) and (E) are opened by the same number of rotations.
 Note 1) If the piston rod jerks, close knob (E) until the smooth operation is achieved.
3. Speed adjustment for return stroke
 The speed is adjusted with the flow valve.
 Open knob (D) gradually until the required speed is achieved.
4. Be sure to tighten the lock nut after adjustment.

Flow Valve: Series ASQ

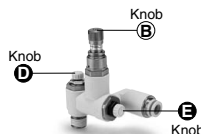

Adjustment Procedure 2

Pressure Adjustment

1. The fixed set pressure type (-F20) does not require adjustment because the pressure is fixed at 0.2 MPa.
2. The pressure at the low pressure side (return stroke side) is adjusted by the pressure valve.
3. The set pressure is adjusted with knob (A). Turn the knob clockwise to increase the pressure and counterclockwise to decrease the pressure.
4. The graduations 1, 2 and 3 correspond to 0.1, 0.2 and 0.3 MPa respectively. Align the bottom end of the knob with the graduated line for adjustment.
5. Keep the set pressure as low as possible in order to achieve good air saving effect.
6. Cap the valve after adjustment.

Pressure Valve: Series ASR



Speed Control

1. The cylinder speed is adjusted with knobs (C), (F) and (G). First have all the knobs fully closed and then open them gradually for adjustment. Turn the knob clockwise to close (decrease the speed of the piston rod) and counterclockwise to open (increase the speed of the piston rod).
2. Speed adjustment for the working stroke
 The speed is adjusted with the pressure valve and the dual speed controller.
 Open knobs (C) and (G) gradually until the required speed is achieved. Make sure that knobs (C) and (G) are opened by the same number of rotations.
 Note 1) If the piston rod jerks, close knob (G) until the smooth operation is achieved.
3. Speed adjustment for return stroke
 The speed is adjusted with the dual speed controller.
 Open knob (F) gradually until the required speed is achieved.
4. Be sure to tighten the lock nut after adjustment.

Dual Speed Controller: Series ASD



AS
TMH
ASD
AS
AS-FE KE
AS-FG
AS-FP
AS-FM
AS-D AS-T
ASP
ASN
AQ
ASV
AK
VCHC
ASS
ASR ASQ

Series ASR/Series ASQ

Construction

Pressure Valve: Series ASR

Variable type

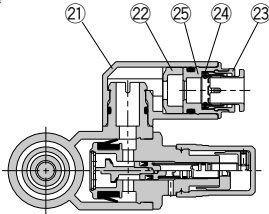

Fixed type

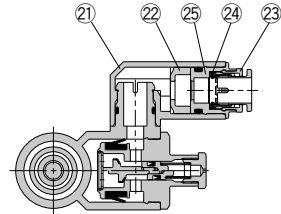

ASR430F-02 type
ASR530F-03 type
ASR630F-04 type

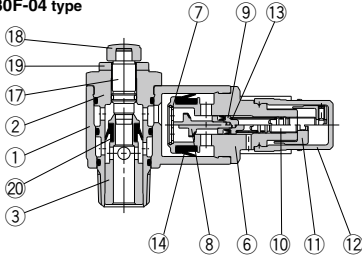

ASR430F-02 type
ASR530F-03 type
ASR630F-04 type

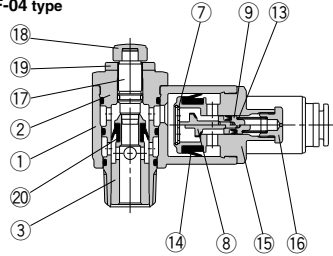

ASR530F-02 type
ASR630F-03 type

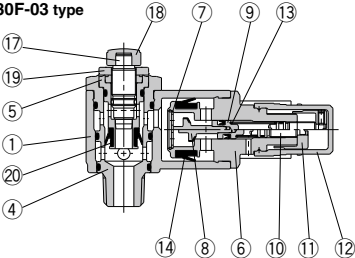

ASR530F-02 type
ASR630F-03 type

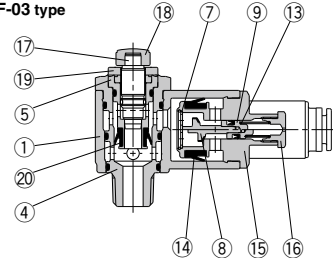

Component Parts

No.	Description	Material	Note
1	Body A	PBT	
2	Body B	Brass	Electroless nickel plated
3	Seat ring	Brass	Electroless nickel plated
4	Body B1	Brass	Electroless nickel plated
5	Body B2	Brass	Electroless nickel plated
6	Body C	Brass	Electroless nickel plated
7	Stopper	Stainless steel	
8	Valve	HNBR/Brass	
9	Piston	Brass	
10	Adjustment screw	Brass	Electroless nickel plated
11	Knob	Brass	Electroless nickel plated
12	Cap	Polypropylene	
13	Adjustment spring	Steel wire	

No.	Description	Material	Note
14	U seal	HNBR	
15	Body C	Brass	Electroless nickel plated
16	Adjustment plug	Brass	Electroless nickel plated
17	Needle	Brass	Electroless nickel plated
18	Knob	PBT	
19	Lock nut	Steel ⁽³⁾	Zinc chromated ⁽³⁾
20	U seal	HNBR	
21	Elbow body	PBT	
22	Spacer ⁽¹⁾	PBT	
23	Cassette	—	
24	Seal	NBR	
25	Drive body ⁽²⁾	Brass	Electroless nickel plated

Note 1) Not used for ø6 and ø8.

Note 2) Not used for ø10 and ø12.

Note 3) The material and surface treatment of the lock nut option-J (round type) is brass and electroless nickel plating, respectively. However, note that only the ASR430F uses steel and electroless nickel plating.

Flow Valve: Series ASQ

Variable type

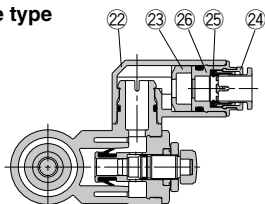

ASQ430F-02 type
ASQ530F-03 type
ASQ630F-04 type

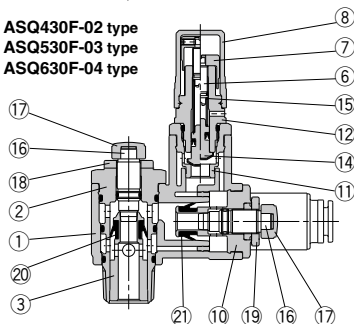

ASQ530F-02 type
ASQ630F-03 type

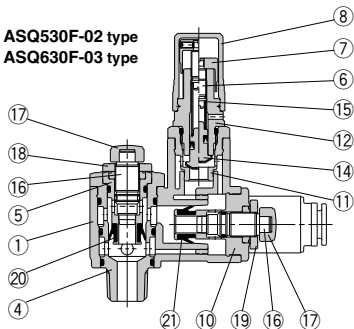

Fixed type

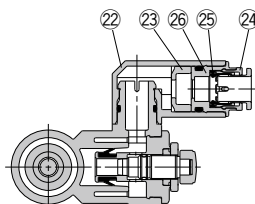

ASQ430F-02 type
ASQ530F-03 type
ASQ630F-04 type

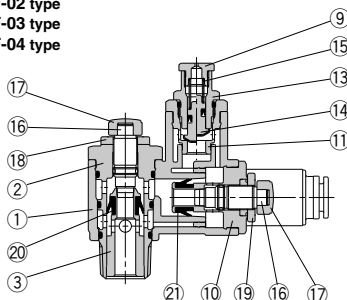

ASQ530F-02 type
ASQ630F-03 type

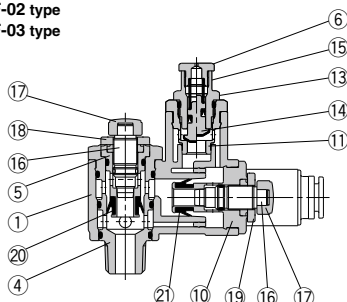

Component Parts

No.	Description	Material	Note
1	Body A	PBT	
2	Body B	Brass	Electroless nickel plated
3	Seat ring	Brass	Electroless nickel plated
4	Body B1	Brass	Electroless nickel plated
5	Body B2	Brass	Electroless nickel plated
6	Adjustment screw	Brass	Electroless nickel plated
7	Knob	Brass	Electroless nickel plated
8	Cap	Polypropylene	
9	Adjustment plug	Brass	Electroless nickel plated
10	Body C	Brass	Electroless nickel plated
11	Body D1	Brass	Electroless nickel plated
12	Body D2	Brass	Electroless nickel plated
13	Body D3	Brass	Electroless nickel plated

No.	Description	Material	Note
14	Piston valve	HNBR/Brass	
15	Adjustment spring	Steel wire	
16	Needle	Brass	Electroless nickel plated
17	Knob	PBT	
18	Lock nut	Steel ⁽³⁾	Zinc chromated ⁽³⁾
19	Lock nut	Steel ⁽³⁾	Black zinc chromated
20	U seal	HNBR	
21	U seal	HNBR	
22	Elbow body	PBT	
23	Spacer ⁽¹⁾	PBT	
24	Cassette	—	
25	Seal	NBR	
26	Drive body ⁽²⁾	Brass	Electroless nickel plated

Note 1) Not used for ø6 and ø8.

Note 2) Not used for ø10 and ø12.

Note 3) The material and surface treatment of the lock nut option-J (round type) is brass and electroless nickel plating, respectively. However, note that only the ASQ430F uses steel and electroless nickel plating.

AS
TMH
ASD
AS
AS-FE KE
AS-FG
AS-FP
AS-FM
AS-D AS-T
ASP
ASN
AQ
ASV
AK
VCHC
ASS
ASR ASQ

Series ASR/Series ASQ

Dimensions

Pressure Valve: Series ASR

Variable set pressure type

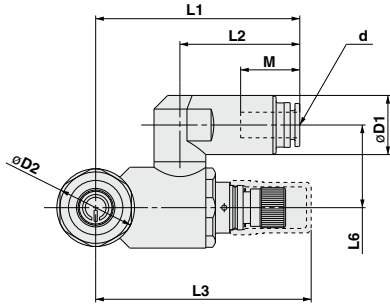

Fixed set pressure type (-F20)

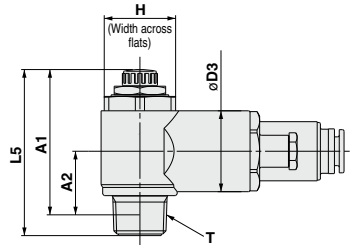
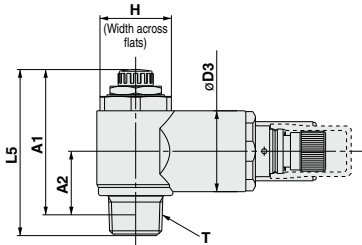
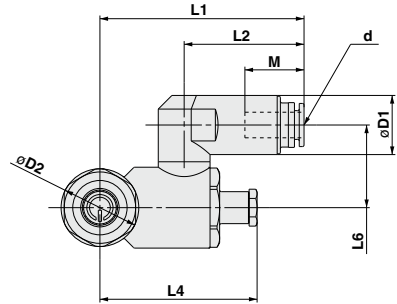

Model	d ⁽¹⁾	T	H	D1	D2	D3	L1	L2	L3 ⁽²⁾	L4 ⁽³⁾	L5 ⁽⁴⁾		L6	A1 ⁽⁵⁾		A2 ⁽⁵⁾	M	Weight (g) ⁽⁶⁾	
											Max.	Min.		Max.	Min.			*1	*2
ASR430F-02-06S,-F20	6						57.7	34.9									17	111	89
ASR430F-02-08S,-F20	8	R1/4	17	18.5	20	21.5	58.7	35.9									18.5	114	93
ASR430F-02-10S,-F20	10						53.8	31									21	105	82
ASR530F-02-06S,-F20	6						62.9	36.5									17	150	127
ASR530F-02-08S,-F20	8						63.9	37.5									18.5	153	130
ASR530F-02-10S,-F20	10	R1/4	21	18.5	24.3	25.3	59	32.6	67.3	49.2	55.8	50.8	25.9	49.8	44.8	18.8	21	143	120
ASR530F-02-12S,-F20	12			20.9			60.8	34.4									22	146	122
ASR530F-03-06S,-F20	6						62.9	36.5									17	160	137
ASR530F-03-08S,-F20	8						63.9	37.5									18.5	163	140
ASR530F-03-10S,-F20	10	R3/8	21	18.5	24.3	25.3	59	32.6	67.3	49.2	57.4	52.4	25.9	51	46	20	21	153	130
ASR530F-03-12S,-F20	12			20.9			60.8	34.4									22	156	133
ASR630F-03-10S,-F20	10						62.8	32.6									21	237	219
ASR630F-03-12S,-F20	12	R3/8	25	18.5	29.7	30	64.6	34.4	86.3	65.5	67.6	60.1	27.7	61.2	53.7	20.6	22	239	221
ASR630F-04-10S,-F20	10						62.8	32.6									21	257	239
ASR630F-04-12S,-F20	12	R1/2	25	18.5	29.7	30	64.6	34.4	86.3	65.5	71.1	63.6	27.7	62.9	55.4	24.1	22	259	239

Note 1) "d" indicates the applicable tubing O.D.

Note 2) L3 is the dimension for the variable set pressure type.

Note 3) L4 is the dimension for the fixed set pressure type.

Note 4) Reference dimensions

Note 5) A1 and A2 are reference dimensions after installation.

Note 6) *1 is the weight for the variable set pressure type and *2 is that for the fixed set pressure type.

Flow Valve: Series ASQ

Variable set pressure type

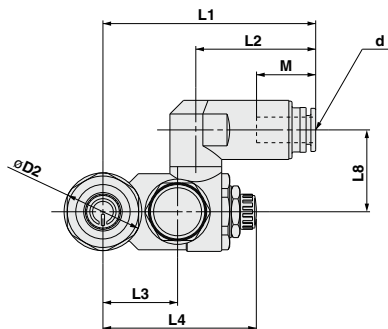

Fixed set pressure type

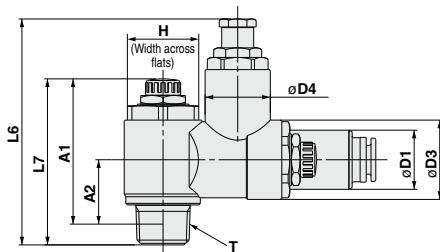
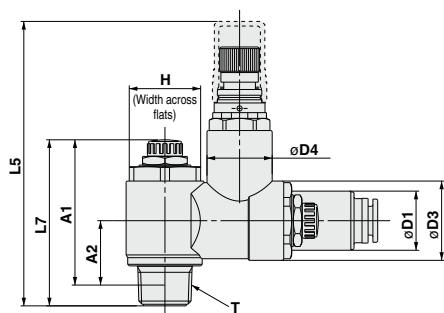
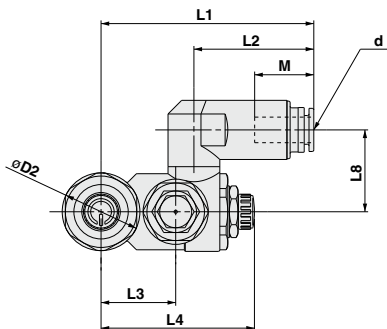

AS
TMH
ASD
AS
AS-FE KE
AS-FG
AS-FP
AS-FM
AS-D AS-T
ASP
ASN
AQ
ASV
AK
VCHC
ASS
ASR ASQ

Model	d ⁽¹⁾	T	H	D1	D2	D3	D4	L1	L2	L3	L4 ⁽²⁾		L5 ⁽³⁾		L6 ⁽⁴⁾		L7 ⁽²⁾		L8	A1 ⁽⁵⁾		A2 ⁽⁵⁾	M	Weight (g) ⁽⁶⁾			
											Max.	Min.			Max.	Min.	Max.	Min.		Max.	Min.			*1	*2		
ASQ430F-02-06S,-F20	6							61.6	34.9														17	136	114		
ASQ430F-02-08S,-F20	8	R1/4	17	18.5	20	21.5	19.5	62.6	35.9	20.3	49.4	44.4	88.8	68.7	50.6	45.6	23	44.6	39.6	17.9			18.5	139	117		
ASQ430F-02-10S,-F20	10							57.7	31														21	130	108		
ASQ530F-02-06S,-F20	6							65.6	36.5															17	178	155	
ASQ530F-02-08S,-F20	8	R1/4	21	18.5	24.3	24.8	20.4	66.6	37.5	23.4	53.5	48.5	92.2	72	55.8	50.8	25.6	49.8	44.8	19			18.5	181	158		
ASQ530F-02-10S,-F20	10							61.7	32.6															21	172	149	
ASQ530F-02-12S,-F20	12			20.9				63.5	34.4															22	174	151	
ASQ530F-03-06S,-F20	6							65.6	36.5																17	188	165
ASQ530F-03-08S,-F20	8	R3/8	21	18.5	24.3	24.8	20.4	66.6	37.5	23.4	53.5	48.5	93.8	73.6	57.4	52.4	25.6	51	46	20.2			18.5	191	168		
ASQ530F-03-10S,-F20	10							61.7	32.6															21	182	159	
ASQ530F-03-12S,-F20	12			20.9				63.5	34.4															22	184	161	
ASQ630F-03-10S,-F20	10	R3/8	25	18.5	29.7	30.7	30	74.8	32.6	30.8	74.3	66.8	107.9	86.9	67.6	60.1	28	61.2	53.7	20.8			21	310	292		
ASQ630F-03-12S,-F20	12			20.9				76.6	34.4															22	312	294	
ASQ630F-04-10S,-F20	10	R1/2	25	18.5	29.7	30.7	30	74.8	32.6	30.8	74.3	66.8	111.4	90.4	71.1	63.6	28	62.9	55.4	24.1			21	330	312		
ASQ630F-04-12S,-F20	12			20.9				76.6	34.4															22	332	314	

Note 1) "d" indicates the applicable tubing O.D..

Note 2) Reference dimensions

Note 3) L5 is the dimension for the variable set pressure type.

Note 4) L6 is the dimension for the fixed set pressure type.

Note 5) A1 and A2 are reference dimensions after installation.

Note 6) *1 is the weight for the variable set pressure type and *2 is that for the fixed set pressure type.



Series ASR/ASQ Specific Product Precautions

Be sure to read before handling. Refer to front matter 56 for Safety Instructions and pages 468 to 471 for Flow Control Equipment Precautions.

Selection

⚠ Warning

1. **Keep the set pressure range of the outlet pressure of the pressure valve within 85% that of the inlet pressure.**

If the value exceeds 85%, the outlet pressure may become unstable, affected by the fluctuation of the inlet pressure.

Installation

⚠ Warning

1. **The number of opening and closing rotations of the needle valve and adjustment screw should be adjusted within the range of the specifications.**

Since it has a pull-out stop mechanism, it will not rotate past the limit. Confirm the number of rotations for the product being used, as excessive turning of the needle will cause damage.

2. **The valve cannot be used if there are load fluctuations.**

The piston rod may jerk during operation.

3. **In case a closed-center solenoid valve is used, switch to the center position only after pressure charge inside the cylinder at the stroke end is completed.**

If the pressure charge is insufficient, the piston rod may jerk after restart.

4. **When the valve is used for an actuator operating vertically, the actuator may lurch depending on the load.**

For the adjustment method, please refer to page 661.

Operating

⚠ Caution

- ① The valve cannot be used if the same pressure is required for both the working and return strokes.
The pressure valve and flow valve are designed to save air by the difference in the operating pressure.
- ② Install a flow valve on the working side which requires the cylinder output and a pressure valve on the return side. The cylinder may not operate if the valves are installed on the wrong sides.

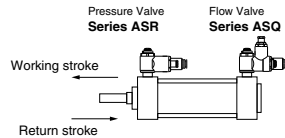

- ③ If a closed-center, exhaust-center, pressure-center or perfect solenoid valve is used and the solenoid valve is set at the center position, the cylinder may move to the position where the pressure balance and load balance are achieved.