

标准规格

缸径 (mm)	6	10	16	20	25	32
流体	空气					
动作型式	双动 单动：弹簧压回 / 弹簧压出					
保证耐压力	1.0MPa {10.5kgf/cm ² }					
最高使用压力	0.7MPa {7.1kgf/cm ² }					
环境和流体温度	5 ~ 60°C					
缓冲	两端橡胶缓冲					
行程公差	+1.0 0					
*润滑	不需要					
安装	自由 (多面安装)					
活塞杆不转动精度 (只限 CUK/CDUK)	±0.8°			±0.5°		
接管口径Rc(PT)	M5X0.8					1/8

*如需要润滑, 请用透平 1 号油 ISOVG32。

型号选择

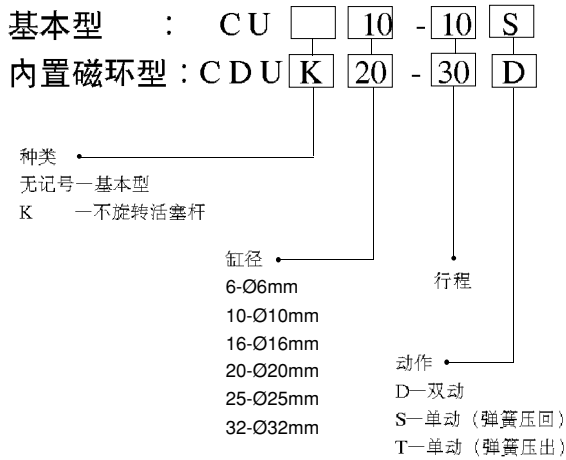

订货举例

- 1) 所需缸径: 6, 行程: 10, 双动, 不旋转活塞杆型
正确型号: CUK6-10D
- 2) 所需缸径: 25, 行程: 25, 单动 (弹簧压回), 内置磁环型。
正确型号: CDU25-25S

行程 / 磁性开关选择

缸径 (mm)	标准行程 (mm)		坑道安装型 *磁性开关
	双动	单动	
6	5,10,	5,10,15	D-A90L
10	15,20, 25,30		D-A93L
16			D-A96L
20	5,10,15, 20,25,30	5,10,15	D-F9NL
25	40,50		D-F9BL
32			

*磁性开关规格特性可参阅磁性开关之系列。

适应性强的装设 / 矩形气缸

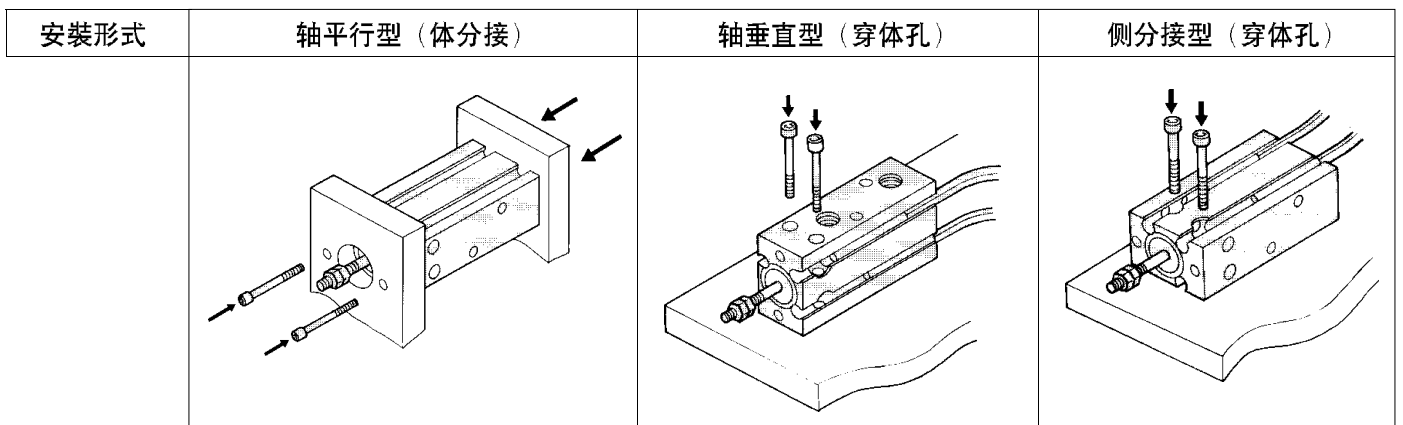

外形尺寸图（毫米）

基本型，内置磁环型
（双动，单动弹簧压回 / 压出）

Ø6, Ø10

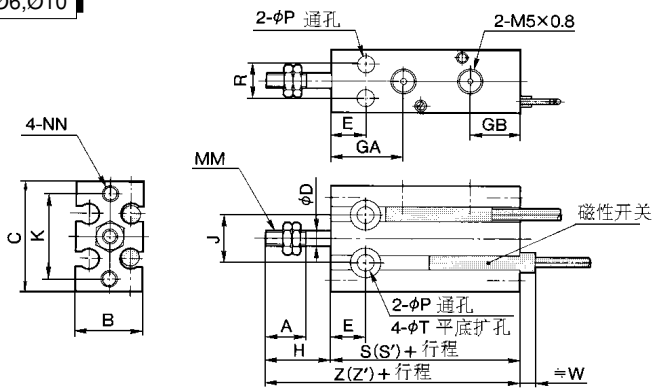

Ø16~Ø25

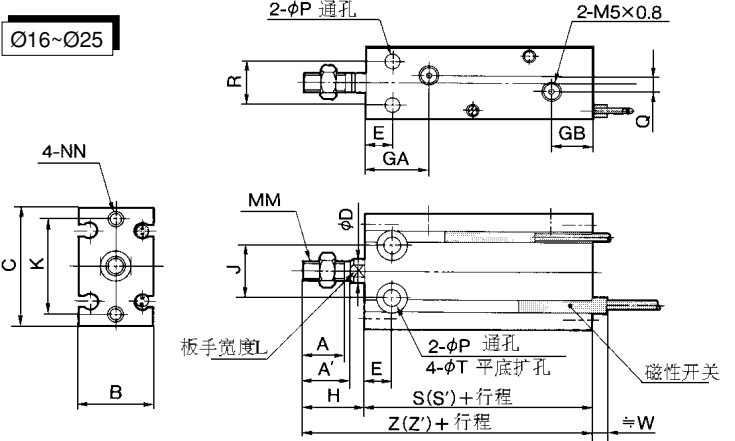

Ø32

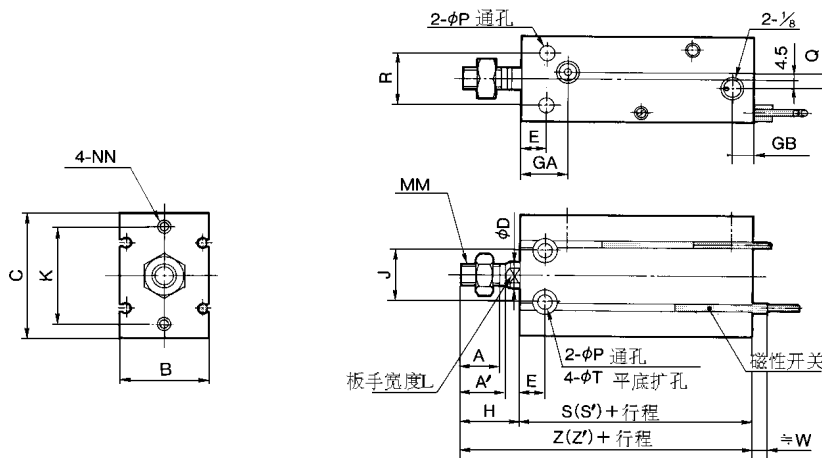

共同尺寸表

型号	A	A'	B	C	ØD	E	GA	GB	J	K	L	MM	NN	ØP	Q	R	ØT
C□U6	7	-	13	22	3	7	14.5	10	10	17	-	M3x0.5	M3X0.5深5	3.4	-	7	6深4.8
C□U10	10	-	15	24	4	7	15.5	10	11	18	-	M4X0.7	M3X0.5深5	3.4	-	9	6深5
C□U16	11	12.5	20	32	6	7	16.5	11.5	14	25	5	M5X0.8	M4X0.7深6	4.5	4	12	7.6深6.5
C□U20	12	14	26	40	8	9	19	12.5	16	30	6	M6X1.0	M5X0.8深8	5.5	9	16	9.5深8
C□U25	15.5	18	32	50	10	10	21	13	20	38	8	M8X1.25	M5X0.8深8	5.5	9	20	9.5深9
C□U32	19.5	22	40	62	12	11	22	13	24	48	10	M10X1.25	M6X1.0深9	6.6	13.5	24	11深11.5

双动尺寸表

型号	H	基本型		内置磁环型		
		S	Z	W	S'	Z'
		5st	10st	15st	5st	10st
C□U6-□D	13	33	46	2.5	33	46
C□U10-□D	16	36	52	1	36	52
C□U16-□D	16	30	46	0	40	56
C□U20-□D	19	36	55	1	46	65
C□U25-□D	23	40	63	-1	50	73
C□U32-□D	27	42	69	-4	52	79

单动（弹簧压回）尺寸表

型号	H	基本型						内置磁环型						
		S			Z			W	S'			Z'		
		5st	10st	15st	5st	10st	15st		5st	10st	15st	5st	10st	15st
		C□U6-□S	13	38	43	48	51		56	61	2.5	38	43	48
C□U10-□S	16	41	46	56	57	62	72	1	41	46	56	57	62	72
C□U16-□S	16	35	40	50	51	56	66	0	45	50	60	61	66	76
C□U20-□S	19	41	46	56	60	65	75	1	51	56	66	70	75	85
C□U25-□S	23	45	50	60	68	73	83	-1	55	60	70	78	83	93
C□U32-□S	27	47	52	62	74	79	89	-4	57	62	72	84	89	99

单动（弹簧压出）尺寸表

型号	H		基本型						内置磁环型							
	5st	10st	S			Z			W	S'			Z'			
	5st	10st	5st	10st	15st	5st	10st	15st		5st	10st	15st	5st	10st	15st	
C□U6-□T	18	23	28	38	43	48	56	66		76	2.5	38	43	48	56	66
C□U10-□T	21	26	31	41	46	56	62	72	87	1	41	46	56	62	72	87
C□U16-□T	21	26	31	45	50	60	66	76	91	0	45	50	60	66	76	91
C□U20-□T	24	29	34	41	46	56	65	75	90	1	51	56	66	75	85	100
C□U25-□T	28	33	38	45	50	60	73	83	98	-1	55	60	70	83	93	108
C□U32-□T	32	37	42	47	52	62	79	89	104	-4	57	62	72	89	99	114

*st=行程

外形尺寸图（毫米）

不旋转活塞杆型，内置磁环型
(双动，单动弹簧压回/压出)

Ø6,Ø10

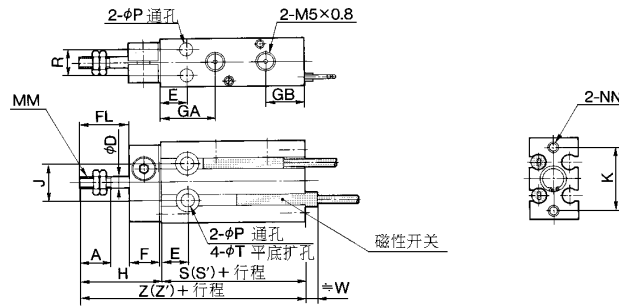
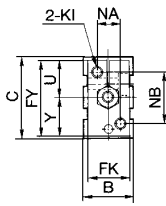

Ø16~25

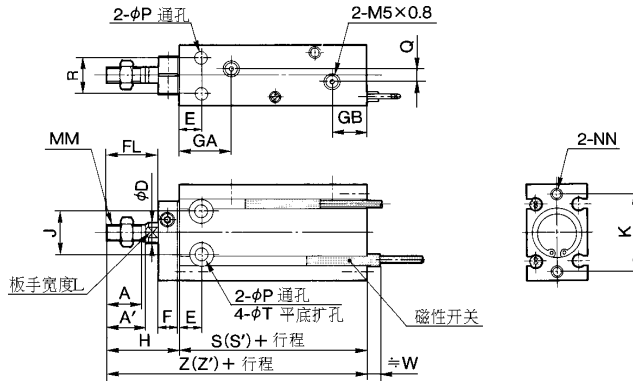
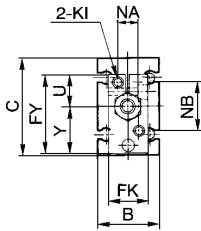

Ø32

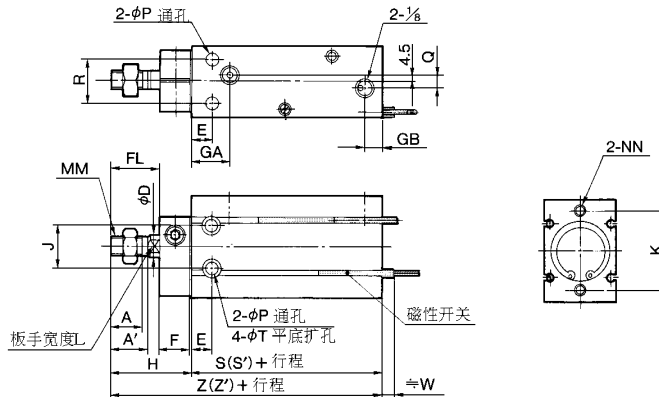
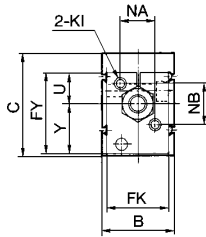

共同尺寸表

型号	A	A'	B	C	ØD	E	F	FL	FK	FY	GA	GB	H	J	K	KI	L	MM	NA	NB	NN	ØP	Q	R	ØT	U	Y
C□UK6	7	-	13	22	3	7	8	9	11	20.5	14.5	10	18	10	17	M3X0.5	-	M3X0.5	6	14	M3X0.5深5	3.4	-	7	6深4.8	10	10.5
C□UK10	10	-	15	24	4	7	8	12	12	22	15.5	10	21	11	18	M3X0.5	-	M4X0.7	7	15	M3X0.5深5	3.4	-	9	6深5	10.5	11.5
C□UK16	11	12.5	20	32	6	7	8	17	13	28	16.5	11.5	26	14	25	M4X0.7	5	M5X0.8	6	18	M4X0.7深6	4.5	4	12	7.6深6.5	12.5	15.5
C□UK20	12	14	26	40	8	9	8	20	16	33	19	12.5	29	16	30	M4X0.7	6	M6X1.0	8	20	M5X0.8深8	5.5	9	16	9.5深8	13.5	19.5
C□UK25	15.5	18	32	50	10	10	10	22	20	43.5	21	13	33	20	38	M5X0.8	8	M8X1.25	10	28	M5X0.8深8	5.5	9	20	9.5深9	19	24.5
C□UK32	19.5	22	40	62	12	11	12	29	24	51.5	22	13	42	24	48	M5X0.8	10	M10X1.25	12	32	M6X1.0深9	6.6	13.5	24	11深11.5	21	30.5

双动尺寸表

型号	H	没有磁环		内置磁环型		
		S	Z	W	S'	Z'
		C□UK6-□D	18	33	51	2.5
C□UK10-□D	21	36	57	1	36	57
C□UK16-□D	26	30	56	0	40	66
C□UK20-□D	29	36	65	1	46	75
C□UK25-□D	33	40	73	-1	50	83
C□UK32-□D	42	42	84	-4	52	94

单动（弹簧压回）尺寸表

型号	H	没有磁环						内置磁环型						
		S			Z			W	S'			Z'		
		5st	10st	15st	5st	10st	15st		5st	10st	15st	5st	10st	15st
C□UK6-□S	18	38	43	48	56	61	66	2.5	38	43	48	56	61	66
C□UK10-□S	21	41	46	56	62	67	77	1	41	46	56	62	67	77
C□UK16-□S	26	35	40	50	61	66	76	0	45	50	60	71	76	86
C□UK20-□S	29	41	46	56	70	75	85	1	51	56	66	80	85	95
C□UK25-□S	33	45	50	60	78	83	93	-1	55	60	70	88	93	103
C□UK32-□S	42	47	52	62	89	94	104	-4	57	62	72	99	104	114

单动（弹簧压出）尺寸表

型号	H			ØT	U	Y	没有磁环						内置磁环型						
	5st	10st	15st				S			Z			W	S'			Z'		
							5st	10st	15st	5st	10st	15st		5st	10st	15st	5st	10st	15st
C□UK6-□T	23	28	33	6深4.8	10	10.5	38	43	48	61	71	81	2.5	38	43	48	61	71	81
C□UK10-□T	26	31	36	6深5	10.5	11.5	41	46	56	67	77	92	1	41	46	56	67	77	92
C□UK16-□T	31	36	41	7.6深6.5	12.5	15.5	45	50	60	76	86	101	0	45	50	60	76	86	101
C□UK20-□T	34	39	44	9.5深8	13.5	19.5	41	46	56	75	85	100	1	51	56	66	85	95	110
C□UK25-□T	38	43	48	9.5深9	19	24.5	45	50	60	83	93	108	-1	55	60	70	93	103	118
C□UK32-□T	47	52	57	11深11.5	21	30.5	47	52	62	94	104	119	-4	57	62	72	104	114	129

*st=行程