

## GFC系列



### 規格

型號	GFC200-06	GFC200-08	GFC300-08	GFC300-10	GFC300-15	GFC400-10	GFC400-15	GFC600-20	GFC600-25	
工作介質	空氣									
接管口徑	PT1/8	PT1/4	PT1/4	PT3/8	PT1/2	PT3/8	PT1/2	PT3/4	PT1	
濾心精度	40 μm或5 μm									
調壓範圍	自動及差壓排水式: 0.15~0.9MPa(20~130psi); 手動排水式: 0.05~0.9MPa(7~130psi)									
最高使用壓力	1.0MPa(145psi)									
保證耐壓力	1.5MPa(215psi)									
使用溫度範圍	-5~70°C(未凍結)									
濾水杯容量	10CC			40CC			80CC		230CC	
給油杯容量	25CC			75CC			160CC		380CC	
建議潤滑油	ISO VG 32或同級用油									
重量	430g		980g			1950g		4320g		
構成元件	調壓過濾器	GFR200-06	GFR200-08	GFR300-08	GFR300-10	GFR300-15	GFR400-10	GFR400-15	GFR600-20	GFR600-25
	給油器	GL200-06	GL200-08	GL300-08	GL300-10	GL300-15	GL400-10	GL400-15	GL600-20	GL600-25

① 接管牙型有NPT、G牙可供選擇。

### 成品訂購碼

#### GFC200 08 M L □ F 1 W G K

<p><b>系列代號</b></p> <ul style="list-style-type: none"> <li>GFC200: G200系列調理組合</li> <li>GFC300: G300系列調理組合</li> <li>GFC400: G400系列調理組合</li> <li>GFC600: G600系列調理組合</li> </ul>	<p><b>接管口徑</b></p> <table border="1"> <thead> <tr> <th>產品系列</th> <th>接管口徑</th> </tr> </thead> <tbody> <tr> <td>GFC200</td> <td>06: 1/8"</td> </tr> <tr> <td></td> <td>08: 1/4"</td> </tr> <tr> <td>GFC300</td> <td>08: 1/4"</td> </tr> <tr> <td></td> <td>10: 3/8"</td> </tr> <tr> <td></td> <td>15: 1/2"</td> </tr> <tr> <td>GFC400</td> <td>10: 3/8"</td> </tr> <tr> <td></td> <td>15: 1/2"</td> </tr> <tr> <td>GFC600</td> <td>20: 3/4"</td> </tr> <tr> <td></td> <td>25: 1"</td> </tr> </tbody> </table>	產品系列	接管口徑	GFC200	06: 1/8"		08: 1/4"	GFC300	08: 1/4"		10: 3/8"		15: 1/2"	GFC400	10: 3/8"		15: 1/2"	GFC600	20: 3/4"		25: 1"	<p><b>逆流閥代碼 ②</b></p> <ul style="list-style-type: none"> <li>空白: 不附逆流閥</li> <li>K: 附逆流閥</li> </ul>
產品系列	接管口徑																					
GFC200	06: 1/8"																					
	08: 1/4"																					
GFC300	08: 1/4"																					
	10: 3/8"																					
	15: 1/2"																					
GFC400	10: 3/8"																					
	15: 1/2"																					
GFC600	20: 3/4"																					
	25: 1"																					
	<p><b>牙型代碼</b></p> <ul style="list-style-type: none"> <li>空白: PT牙</li> <li>T: NPT牙</li> <li>G: G牙</li> </ul>	<p><b>過濾精度</b></p> <ul style="list-style-type: none"> <li>空白: 40 μm級</li> <li>W: 5 μm級</li> </ul>																				
	<p><b>刻度單位</b></p> <ul style="list-style-type: none"> <li>1: MPa</li> <li>2: psi</li> <li>3: bar</li> </ul>	<p><b>壓力表型式</b></p> <ul style="list-style-type: none"> <li>F: 方形表</li> <li>C: 圓形表</li> </ul>																				
<p><b>排水方式</b></p> <table border="1"> <thead> <tr> <th>排水方式</th> <th>適用產品系列</th> </tr> </thead> <tbody> <tr> <td>空白: 差壓排水式</td> <td>GFC200/GFC300</td> </tr> <tr> <td>M: 手動排水式</td> <td>GFC400/GFC600</td> </tr> <tr> <td>A: 自動排水式</td> <td>GFC300/GFC400/GFC600</td> </tr> </tbody> </table>	排水方式	適用產品系列	空白: 差壓排水式	GFC200/GFC300	M: 手動排水式	GFC400/GFC600	A: 自動排水式	GFC300/GFC400/GFC600	<p><b>型式代碼</b></p> <ul style="list-style-type: none"> <li>空白: 標準型</li> <li>L: 低壓型 ①</li> </ul>	<p><b>壓力表代碼</b></p> <ul style="list-style-type: none"> <li>空白: 附表</li> <li>N: 不附表</li> </ul>												
排水方式	適用產品系列																					
空白: 差壓排水式	GFC200/GFC300																					
M: 手動排水式	GFC400/GFC600																					
A: 自動排水式	GFC300/GFC400/GFC600																					

① 低壓型最大可調壓力為: 0.4MPa(58psi); ② 逆流閥更詳細內容請參考P146頁。

### 符號

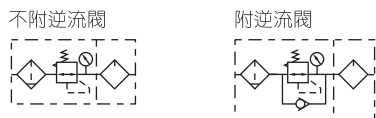

### 產品特性

- 1、快速、可靠的固定連接，安裝使用方便；
- 2、壓力調節穩定、重複精度高；
- 3、高效率的水份和固體顆粒去除功能；
- 4、有手動、差壓及自動排水等三種排水形式可供選擇。

### 內部結構

<p>型號: GFC200</p>	<p>型號: GFC600</p>								
<table border="1"> <thead> <tr> <th>序號</th> <th>名稱</th> </tr> </thead> <tbody> <tr> <td>①</td> <td>G系列調壓過濾器</td> </tr> <tr> <td>②</td> <td>連接支架</td> </tr> <tr> <td>③</td> <td>G系列給油器</td> </tr> </tbody> </table>		序號	名稱	①	G系列調壓過濾器	②	連接支架	③	G系列給油器
序號	名稱								
①	G系列調壓過濾器								
②	連接支架								
③	G系列給油器								

## GFC系列

### ■ 壓力及流量特性

#### 壓力特性

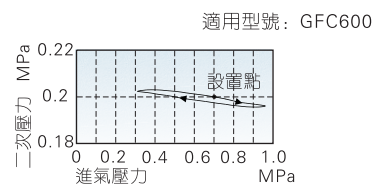
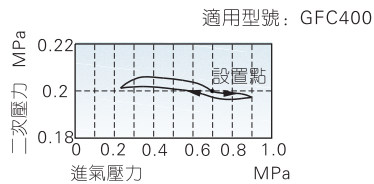
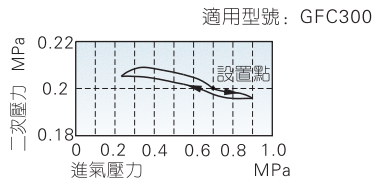
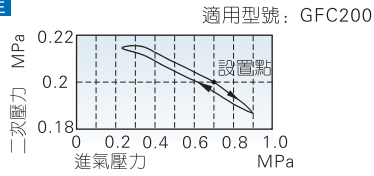

#### 流量特性

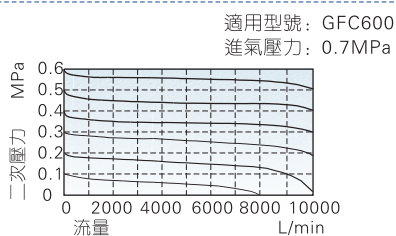
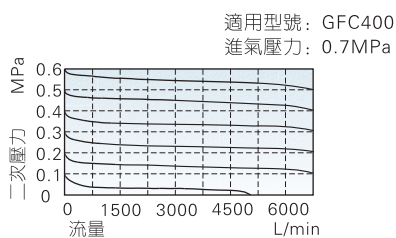
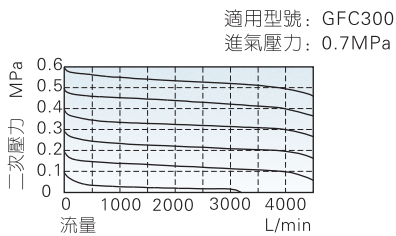
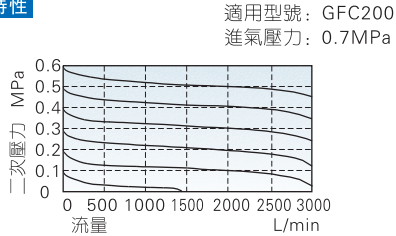

### ■ 外部規格

#### GFC200

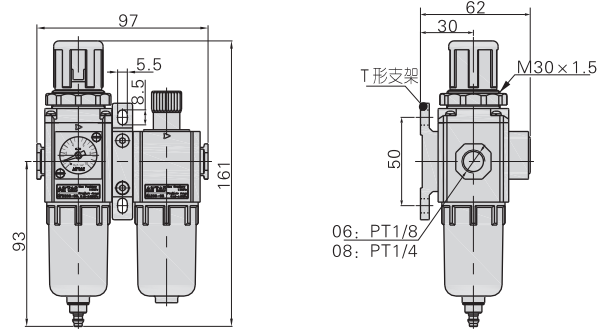

#### GFC300/GFC400

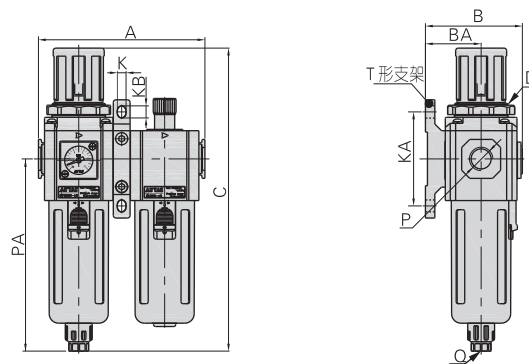

型號符號	A	B	BA	C	D	K	KA	KB	P	PA	Q
GFC300-08	124	72	41.5	225.5	M40x1.5	6.5	70	9	PT1/4	143	G1/8
GFC300-10	124	72	41.5	225.5	M40x1.5	6.5	70	9	PT3/8	143	G1/8
GFC300-15	124	72	41.5	225.5	M40x1.5	6.5	70	9	PT1/2	143	G1/8
GFC400-10	164	89	50	270.5	M55x2.0	8.5	80	12	PT3/8	166.5	G1/4
GFC400-15	164	89	50	270.5	M55x2.0	8.5	80	12	PT1/2	166.5	G1/4

#### GFC600

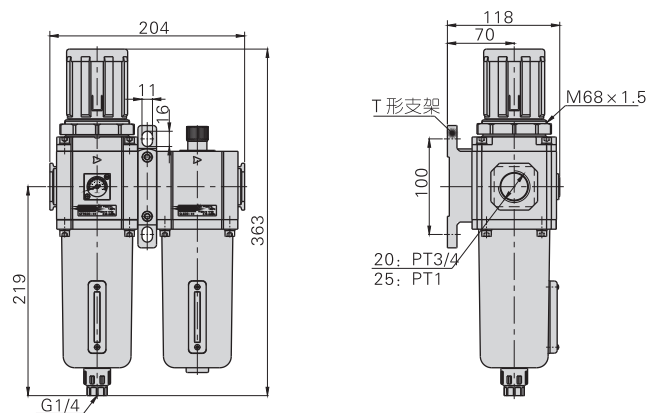

GFC