

Rotary Actuator/Vane Style

Series CRB2

Size: 10, 15, 20, 30, 40

Basic style
Series CRB2



With angle adjuster
Series CRB2BWU



Standard		Fluid		Air																	
		Size		10				15				20,30				40					
Vane type		Single vane (S) Double vane (D)		S		D		S		D		S		D		S		D			
Port location		Side ported (Nil) Axial ported (E)		Side ported	Axial ported	Side ported	Axial ported	Side ported	Axial ported	Side ported	Axial ported	Side ported	Axial ported	Side ported	Axial ported	Side ported	Axial ported	Side ported	Axial ported		
Rotating angle	90°	●																			
	100°	●																			
	180°	●																			
	270°	●																			
Shaft type	Double shaft	W		●																	
Cushion	Rubber bumper		●																		
Variations	Basic type		●																		
	With auto switch		●																		
	With angle adjuster		●																		
	With auto switch and angle adjuster		●																		
	Copper-free and fluorine-free		20-		●																
Option	Mounting style	With flange		F		●															
Made to Order	Shaft type	Double shaft type	Long shaft without single flat & Short shaft with single flat	J		●															
			Long shaft without keyway & Short shaft with single flat	J		●															
		Single shaft type	Same length double long shaft with single flat on both shafts	Y		●															
			Double shaft key	Y		●															
	Single shaft type	Double round shaft	K		●																
		Single flat	S		●																
		Single shaft key	S		●																
	Pattern	Single round shaft		T		●															
Shaft pattern		●																			
Rotation pattern		●																			

CRB2

CRBU2

CRB1

MSU

CRJ

CRA1

CRQ2

MSQ

MSZ

CRQ2X
MSQX

MRQ

D-□

Rotary Actuator for Vane Style

**Rotating angle: 90°, 180°, 270°
All series can rotate up to 270°.**

The use of specially designed seals and stoppers now enables our compact vane type rotary actuators to rotate up to 270°. (Single vane type)

Direct mounting

The body of rotary actuator can be mounted directly.
* Not possible to use direct mount type with units sized 10 to 40.

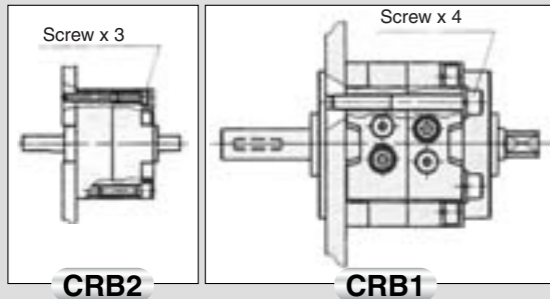

Unrestricted auto switch mounting position

Since the switches can be moved anywhere along the circumference of rotary actuator, they can be mounted at the optimum position according to the rotary actuator's specifications.



Direct mounting from 3 different directions is possible (CRBU2).

Series CRBU2 can be mounted in 3 directions: axial, vertical, and lateral. In the axial direction, there are 4 mounting variations.

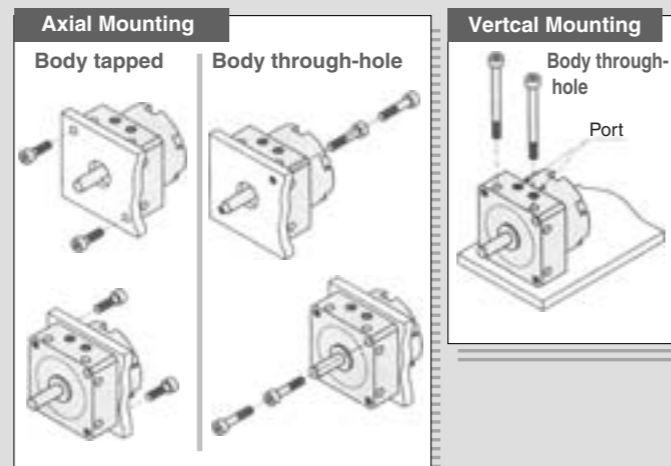

Excellent reliability and durability

Bearings are used in all series to support thrust and radial loads. The use of a rubber bumper (except size 10) further improves reliability.

Two different connecting port locations (side and axial) are available.

The port location can be selected according to the application. (Types with various units sized 10 to 40 are body side face only.)

Low pressure operation

Special seal construction allows for a broader operating pressure range and makes operation in low pressure applications possible.

Min. operating pressure

Size 10: 0.2 MPa

Size 15 to 100: 0.15 MPa

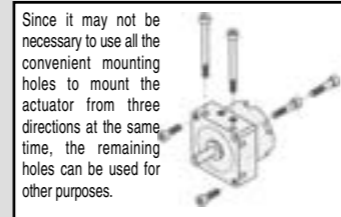

Since it may not be necessary to use all the convenient mounting holes to mount the actuator from three directions at the same time, the remaining holes can be used for other purposes.

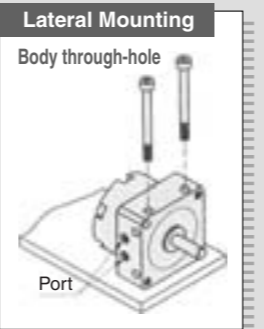

**CRB2/Size:
10, 15, 20, 30, 40**



**Free mount type
CRBU2/Size:
10, 15, 20, 30, 40**



**CRB1/Size:
50, 63, 80, 100**

Double vane construction is now a standard feature for 90° and 100° rotation type actuators.

Although the outside dimensions of the double vane construction actuators are equivalent to those of the single vane construction type (except for size 10). Double vane construction can get twice the torque of the single vane style.

Model	Single vane	Model					
		90°	100°	180°	190°	270°	280°
CRB2	Single vane	●		●		●	
	Double vane	●	●	●		●	
CRBU2	Single vane	●		●		●	
	Double vane	●	●	●		●	
CRB1	Single vane	●	●	●	●	●	●
	Double vane	●	●	●	●	●	●

Block (Unit) type construction

For all series' rotary actuator's single body, various units for body outside diameter integral type can be easily retrofit.

Basic Type + Switch Unit



Basic Type + Angle Adjuster



Basic Type + Angle Adjuster + Switch Unit



- CRB2
- CRBU2
- CRB1
- MSU
- CRJ
- CRA1
- CRQ2
- MSQ
- MSZ
- CRQ2X
- MSQX
- MRQ

D-□

Rotary Actuator Vane Style

Series *CRB2*

Size: 10, 15, 20, 30, 40

How to Order

Without auto switch

**With auto switch
Size: 10, 15**

**With auto switch
Size: 20, 30, 40**

With auto switch
(With auto switch unit and built-in magnet)
* Refer to page 141 when the auto switch unit is needed separately.

CRB2 **B** **W** **□** **□** - **180** **S** **E** **□**

CDRB2 **F** **W** **□** **□** - **180** **S** - **T99** **L** **□** **□**

CDRB2 **B** **W** **□** **□** - **180** **S** - **T79** **L** **□** **□**

Mounting style

B	Basic style
F	Flange style

* F: Except size 40

Shaft type

W	Double shaft with single flat (Size 10 to 30)
	Long shaft key, Short shaft with single flat (Size 40)

Pattern

Nil	Standard
P	Simple Specials/Made to Order

Rotating angle

Single vane	90	90°
	180	180°
	270	270°
Double vane	90	90°
	100	100°

Vane type

S	Single vane
D	Double vane

Auto switch

Nil	Without auto switch (built-in magnet)
------------	---------------------------------------

Connecting port location

Nil	Side ported
E	Axial ported

Size

10
15
20
30
40

Made to Order
Refer to the table below for details.

Number of auto switches

S	1 pc. *
Nil	2 pcs. **

* S (1 auto switch) is shipped with a right-hand auto switch.
** Nil (2 auto switches) is shipped with a right-hand and a left-hand switch.

Electrical entry/Lead wire length

Nil	Grommet/Lead wire 0.5 m
L	Grommet/Lead wire: 3 m
C	Connector/Lead wire 0.5 m
CL	Connector/Lead wire: 3 m
CN	Connector/Without lead wire

* Connectors are available only for auto switch types R73, R80 and T79.
** Lead wire with connector part nos.
D-LC05: Lead wire 0.5 m
D-LC30: Lead wire 3 m
D-LC50: Lead wire 5 m

* For details, refer to pages 69 to 80.
* For the applicable auto switch model, refer to the table below.

Applicable Auto Switches/Refer to pages 761 to 809 for further information on auto switches.

Applicable size	Type	Electrical entry	Indicator light	Wiring (Output)	Load voltage		Auto switch model	Lead wire type	Lead wire length (m) *				Applicable load		
					DC	AC			0.5 (Nil)	3 (L)	5 (Z)	None (N)			
For 10 and 15	Solid state switch	Grommet	Yes	2-wire	24V	12V	T99	Heavy-duty cord	●	●	—	—	IC circuit	Relay, PLC	
									●	●	—	—			
									●	●	—	—			
									●	●	—	—			
									●	●	—	—			
									●	●	—	—			
For 10 and 15	Reed switch	Grommet	No	2-wire	24V	5V, 12V	90	Parallel cord	●	●	●	—	IC circuit	Relay, PLC	
									●	●	●	—			
									●	●	●	—			
									●	●	●	—			
									●	●	●	—			
									●	●	●	—			
For 20, 30 and 40	Solid state switch	Grommet	Yes	2-wire	24V	12V	T79	Heavy-duty cord	●	●	—	—	IC circuit	Relay, PLC	
									●	●	●	●			
									●	●	—	—			
									●	●	—	—			
									●	●	—	—			
									●	●	—	—			
	Reed switch	Grommet	Yes	2-wire	24V	—	100V	R73	Heavy-duty cord	●	●	—	—	IC circuit	Relay, PLC
										●	●	●	●		
										●	●	●	●		
										●	●	●	●		
										●	●	●	●		
										●	●	●	●		
Reed switch	Connector	No	2-wire	24V	—	100V	R73C	Heavy-duty cord	●	●	—	—	IC circuit	Relay, PLC	
									●	●	—	—			
									●	●	—	—			
									●	●	—	—			
									●	●	—	—			
									●	●	—	—			
Reed switch	Grommet	No	2-wire	24V	—	48V, 100V	R80	Heavy-duty cord	●	●	—	—	IC circuit	Relay, PLC	
									●	●	—	—			
									●	●	—	—			
									●	●	—	—			
									●	●	—	—			
									●	●	—	—			
Reed switch	Connector	No	2-wire	24V	—	24 V or less	R80C	Heavy-duty cord	●	●	●	●	IC circuit	Relay, PLC	
									●	●	●	●			
									●	●	●	●			
									●	●	●	●			
									●	●	●	●			
									●	●	●	●			

* Lead wire length symbols: 0.5 m Nil (Example) R73C
3 m L (Example) R73CL
5 m Z (Example) R73CZ
None N (Example) R73CN

Flange Assembly Part No.

(For details, refer to page 52.)

Model	Assembly part no.
CRB2FW10	P211070-2
CRB2FW15	P211090-2
CRB2FW20	P211060-2
CRB2FW30	P211080-2

Made to Order
(Refer to pages 69 to 73, 79 and 80 for details.)

Symbol	Specifications/Description
XA1 to XA24	Shaft type pattern
XC 1	Add connection port
XC 2	Change threaded hole to through-hole
XC 3	Change the screw position
XC 4	Change rotation range
XC 5	Change rotation range between 0 and 200°
XC 6	Change rotation range between 0 and 110°
XC 7	Reversed shaft
XC30	Fluorine grease

The above may not be selected when the product comes with an auto switch or angle adjustment unit. Refer to pages 69, 70 and 79 for details.

Single Vane Specifications

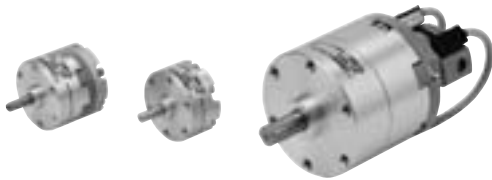

Model (Size)		CRB2BW10-□S	CRB2BW15-□S	CRB2BW20-□S	CRB2BW30-□S	CRB2BW40-□S
Vane type		Single vane				
Rotating angle		90°, 180°	270°	90°, 180°	270°	90°, 180°, 270°
Fluid		Air (Non-lube)				
Proof pressure (MPa)		1.05			1.5	
Ambient and fluid temperature		5 to 60°C				
Max. operating pressure (MPa)		0.7			1.0	
Min. operating pressure (MPa)		0.2	0.15			
Rotation time adjustment range s/90°⁽¹⁾		0.03 to 0.3			0.04 to 0.3	0.07 to 0.5
Allowable kinetic energy (J)⁽²⁾		0.00015	0.001	0.003	0.02	0.04
Shaft load (N)	Allowable radial load	15	15	25	30	60
	Allowable thrust load	10	10	20	25	40
Bearing type		Bearing				
Port location		Side ported or Axial ported				
Port size	Side ported	M5 x 0.8	M3 x 0.5	M5 x 0.8	M3 x 0.5	M5 x 0.8
	Axial ported	M3 x 0.5			M5 x 0.8	
Shaft type		Double shaft (Double shaft with single flat on both shafts)				Double shaft (Long shaft flat & single flat)
Angle adjustable range⁽³⁾		0 to 230°	0 to 240°			0 to 230°
Mounting		Basic style, Flange style				Basic
Auto switch		Mountable (Side ported only)				

Note 3) Adjustment range in the table is for 270°. For 90° and 180°, refer to page 142.

Double Vane Specifications

Model (Size)		CRB2BW10-□D	CRB2BW15-□D	CRB2BW20-□D	CRB2BW30-□D	CRB2BW40-□D
Vane type		Double vane				
Rotating angle		90°, 100°				
Fluid		Air (Non-lube)				
Proof pressure (MPa)		1.05			1.5	
Ambient and fluid temperature		5 to 60°C				
Max. operating pressure (MPa)		0.7			1.0	
Min. operating pressure (MPa)		0.2	0.15			
Rotation time adjustment range s/90°⁽¹⁾		0.03 to 0.3			0.04 to 0.3	0.07 to 0.5
Allowable kinetic energy (J)		0.0003	0.0012	0.0033	0.02	0.04
Shaft load (N)	Allowable radial load	15	15	25	30	60
	Allowable thrust load	10	10	20	25	40
Bearing type		Bearing				
Port location		Side ported or Axial ported				
Port size (Side ported, Axial ported)		M3 x 0.5			M5 x 0.8	
Shaft type		Double shaft (Double shaft with single flat on both shafts)				
Angle adjustable range⁽³⁾		0 to 90°				
Mounting		Basic style, Flange style				Basic style
Auto switch		Mountable (Side ported only)				

Note 1) Make sure to operate within the speed regulation range. Exceeding the maximum speed (0.3 sec/90°) can cause the unit to stick or not operate.

Note 2) The upper numbers in this section in the table indicate the energy factor when the rubber bumper is used (at the end of the rotation), and the lower numbers indicate the energy factor when the rubber bumper is not used.

Note 3) Adjustment range in the table is for 100°. For 90°, refer to page 142.

JIS Symbol

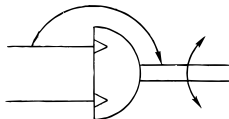

Volume

Vane type	Single vane										Double vane														
	Model		CRB2BW10-□S	CRB2BW15-□S	CRB2BW20-□S	CRB2BW30-□S	CRB2BW40-□S	CRB2BW10-□D	CRB2BW15-□D	CRB2BW20-□D	CRB2BW30-□D	CRB2BW40-□D	CRB2BW10-□D	CRB2BW15-□D	CRB2BW20-□D	CRB2BW30-□D	CRB2BW40-□D								
Rotation	90°	180°	270°	90°	180°	270°	90°	180°	270°	90°	180°	270°	90°	100°	90°	100°	90°	100°	90°	100°	90°	100°			
Volume	1 (0.6)	1.2	1.5	1.5 (1.0)	2.9	3.7	4.8 (3.6)	6.1	7.9	11.3 (8.5)	15	20.2	25 (18.7)	31.5	41	1.0	1.1	2.6	2.7	5.6	5.7	14.4	14.5	33	34

* Values inside () are volume of the supply side when A port is pressurized.

Mass

Vane type	Single vane										Double vane														
	Model		CRB2BW10-□S	CRB2BW15-□S	CRB2BW20-□S	CRB2BW30-□S	CRB2BW40-□S	CRB2BW10-□D	CRB2BW15-□D	CRB2BW20-□D	CRB2BW30-□D	CRB2BW40-□D	CRB2BW10-□D	CRB2BW15-□D	CRB2BW20-□D	CRB2BW30-□D	CRB2BW40-□D								
Rotating angle	90°	180°	270°	90°	180°	270°	90°	180°	270°	90°	180°	270°	90°	100°	90°	100°	90°	100°	90°	100°	90°	100°			
Body of rotary actuator	26.3	26.0	25.7	50	49	48	106	105	103	203	198	193	387	376	365	42	43	57	60	121	144	223	243	400	446
Flange assembly	9		10		19		25		—		9		10		19		25		—		—		—		
Auto switch unit + 2 switches	30		30		50		60		46.5		30		30		50		60		46.5		—		—		
Angle adjuster	30		47		90		150		203		30		47		90		150		203		—		—		

CRB2

CRBU2

CRB1

MSU

CRJ

CRA1

CRQ2

MSQ

MSZ

CRQ2X

MSQX

MRQ

D-□

Series CRB2

Rotary Actuator: Replaceable Shaft

A shaft can be replaced with a different shaft type except for standard shaft type (W).

Without auto switch CRB2B J P Size — Rotating angle Vane type Port location — Made to order

Shaft type

Symbol	Shaft type	Shaft-end shape	Size				
			10	15	20	30	40
J	Double shaft	Long shaft without single flat & with single flat	●	●	●	●	●
		Long shaft without keyway & with single flat					●
K	Double shaft	Double round shaft					●
S	Single shaft	Single shaft with single flat	●	●	●	●	●
		Single shaft key					●
T	Single shaft	Single round shaft	●	●	●	●	●
Y	Double shaft	Double shaft with single flat	●	●	●	●	●
		Double shaft key					●

Pattern	
Nil	Without Made to Order
P	Simple Specials/Made to Order

Made to order

Symbol	Description
XA31 to XA58	Shaft type pattern
XC 1	Add connection port
XC 2	Change threaded hole to through-hole
XC 3	Change the screw position
XC 4	Change rotation range
XC 5	Change rotation range between 0 and 200°
XC 6	Change rotation range between 0 and 110°
XC 7	Reversed shaft
XC30	Fluorine grease

For details, refer to pages 74 to 80.

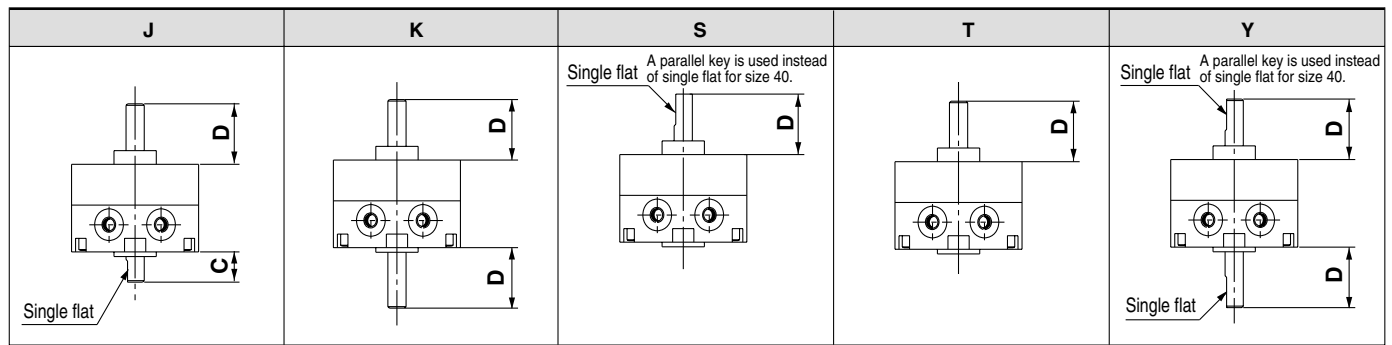

Size	10	15	20	30	40
C	8	9	10	13	15
D	14	18	20	22	30

Note) Dimensions and tolerance of the shaft and single flat (a parallel key for size 40) are the same as the standard.

With auto switch With angle adjusted CDRB2B J U P Size — Rotating angle Vane type — Made to order

With auto switch

With angle adjuster

Shaft type

Symbol	Shaft type	Shaft-end shape	Size				
			10	15	20	30	40
J	Double shaft	Long shaft without single flat & with single flat	●	●	●	●	
		Long shaft without keyway & with single flat					●

Pattern	
Nil	Without Made to Order
P	Simple Specials/Made to Order

Made to order

Symbol	Description
XA31 to XA58	Shaft type pattern
XC 1	Add connection port
XC 2	Change threaded hole to through-hole
XC 3	Change the screw position
XC 4	Change rotation range
XC 5	Change rotation range between 0 and 200°
XC 6	Change rotation range between 0 and 110°
XC 7	Reversed shaft
XC30	Fluorine grease

The above may not be selected when the product comes with an auto switch or angle adjustment unit. Refer to pages 74, 75 and 79 for details.

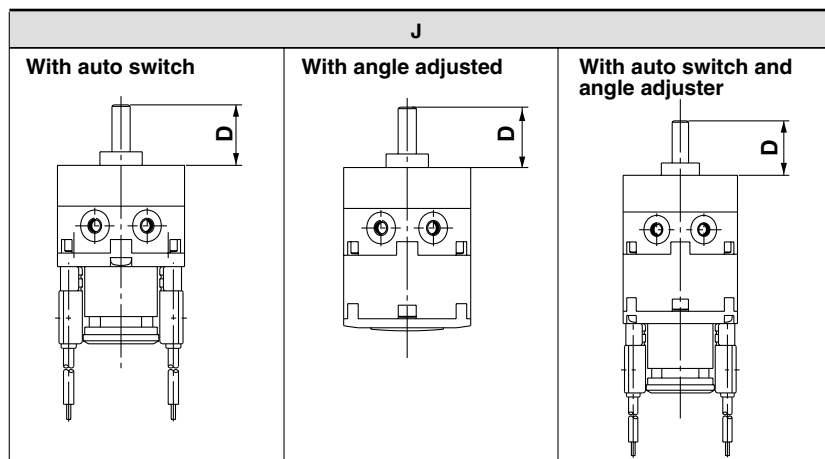

Size	10	15	20	30	40
D	14	18	20	22	30

Note 1) Only side ports are available except for basic type.
Note 2) Dimensions and tolerance of the shaft and single flat (a parallel key for size 40) are the same as the standard.

Copper-free and Fluorine-free Rotary Actuator

20 – CRB2BW **P** **Size** – **Rotating angle** **Vane type** **Port location** – **Made to order**

● **Pattern**

Nil	Without Made to Order
P	Simple Specials/Made to Order

● **Copper-free and fluorine-free**

Use the standard vane type rotary actuators in all series to prevent any adverse effects to CRTs due to copper ions or fluororesin.

● **Made to order**

Symbol	Description
XA1 to XA24	Shaft type pattern
XC 1	Add connection port
XC 2	Change threaded hole to through-hole
XC 3	Change the screw position
XC 4	Change rotation range
XC 5	Change rotation range between 0 and 200°
XC 6	Change rotation range between 0 and 110°
XC 7	Reversed shaft

The above may not be selected when the product comes with an auto switch or angle adjustment unit. Refer to pages 69, 70 and 79 for details.

Specifications

Vane type	Single/Double vane				
	10	15	20	30	40
Size					
Operating pressure range (MPa)	0.2 to 0.7	0.15 to 0.7	0.15 to 1.0		
Speed regulation range (s/90°)	0.03 to 0.3		0.04 to 0.3	0.07 to 0.5	
Port location	Side ported or axial ported (Basic style only)				
Piping	Screw-in type				
Mounting	Basic style only				
Variations	Basic style, With auto switch, With angle adjuster				

CRB2

CRBU2

CRB1

MSU

CRJ

CRA1

CRQ2

MSQ

MSZ

CRQ2X
MSQX

MRQ

Precautions

Be sure to read before handling. Refer to front matters 38 and 39 for Safety Instructions and pages 4 to 13 for Rotary Actuator and Auto Switch Precautions.

Angle Adjuster

Caution

1. Since the maximum angle of the rotation adjustment range will be limited by the rotation of the rotary actuator itself, make sure to take this into consideration when ordering.

Refer to the table below.

Rotating angle of the rotary actuator	Rotating angle adjustment range
270° ⁺⁴ / ₀	0° to 230° (Size: 10, 40) *1
	0° to 240° (Size: 15, 20, 30)
180° ⁺⁴ / ₀	0° to 175°
90° ⁺⁴ / ₀	0° to 85°

*1 The maximum adjustment angle of the angle adjuster for size 40 is 230°.

2. Connection ports are side ports only.
3. The allowable kinetic energy is the same as the specifications of the rotary actuator by itself (i.e., without angle adjuster).
4. Use a 100° rotary actuator if you desire to adjust the angle to 90° using a double vane type.

D-□

Series CRB2

Option Specifications: Flange (Size: 10, 15, 20, 30)



Basic type	Type			Flange assembly part no.
	With auto switch	With angle adjuster	With angle adjuster and auto switch	
CRB2FW10	CDRB2FW10	CRB2FWU10	CDRB2FWU10	P211070-2
CRB2FW15	CDRB2FW15	CRB2FWU15	CDRB2FWU15	P211090-2
CRB2FW20	CDRB2FW20	CRB2FWU20	CDRB2FWU20	P211060-2
CRB2FW30	CDRB2FW30	CRB2FWU30	CDRB2FWU30	P211080-2



Note 1) The flange (with countersunk head screws) is not mounted on the actuator at the time of shipment.

Note 2) The flange can be mounted on the rotary actuator at 60-degree intervals.

Assembly Part No.: P211070-2 (for C□RB2FW□10)

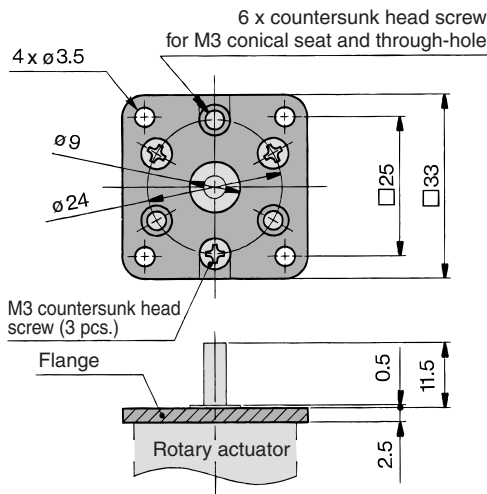

Assembly Part No.: P211090-2 (for C□RB2FW□15)

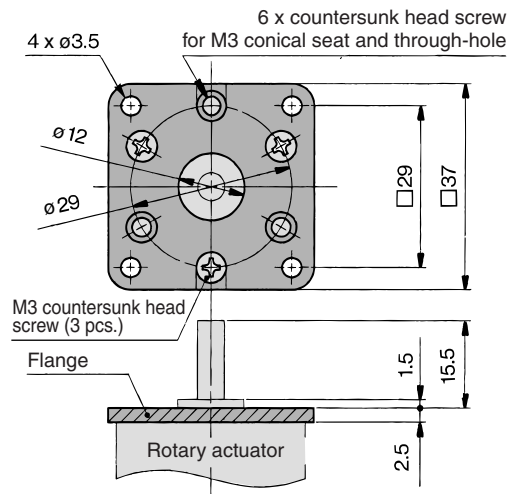

Assembly Part No.: P211060-2 (for C□RB2FW□20)

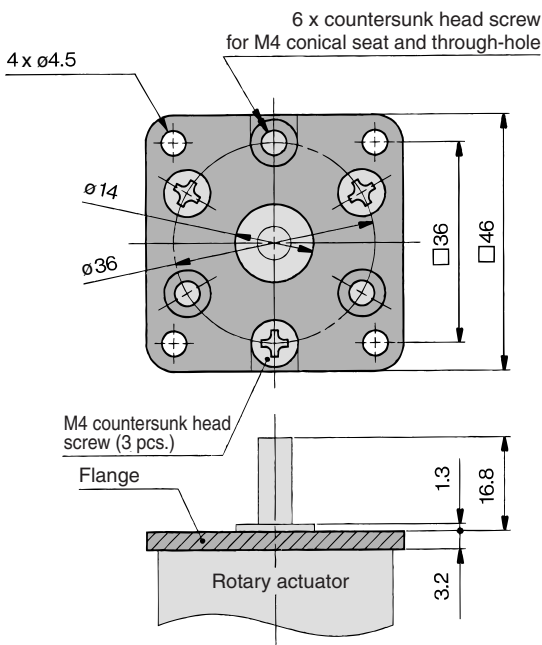

Assembly Part No.: P211080-2 (for C□RB2FW□30)

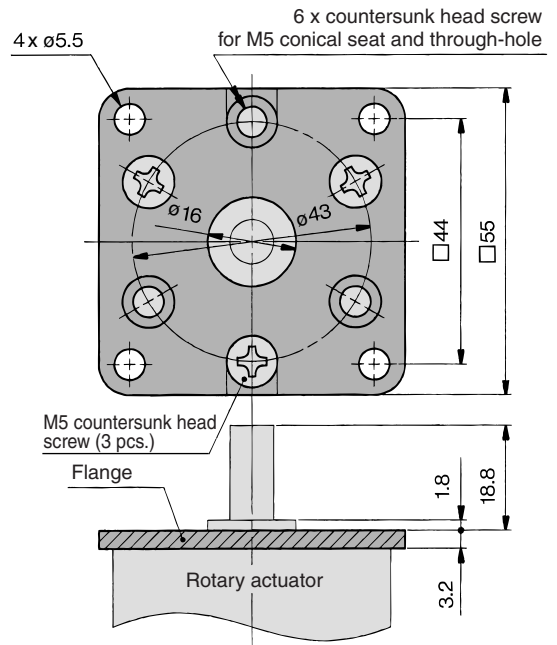

Effective Output

Direct Mounting of Body

CRB2BW10

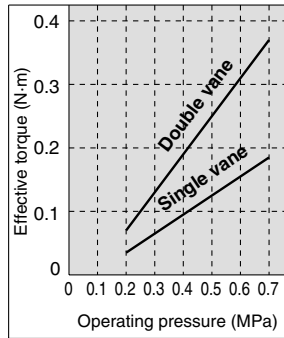

CRB2BW15

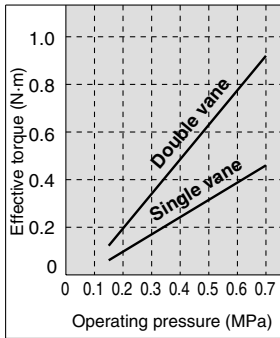

CRB2BW20

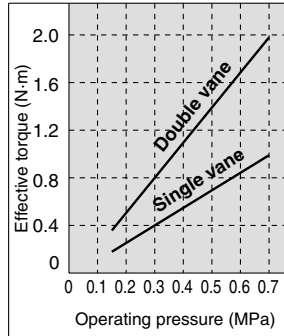

CRB2BW30

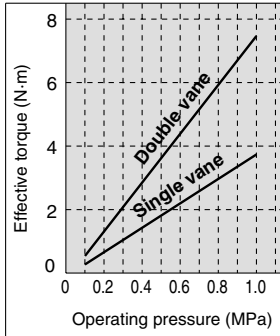

CRB2BW40

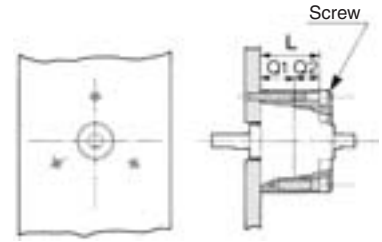
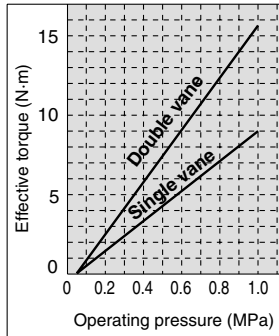

Dimension "L" of the actuators is provided in the table below for JIS standard hexagon socket head cap screws. If these types of screw are used, their heads will fit in the mounting hole.

Model	L	Screw
CRB2BW10	11.5 *	M2.5
CRB2BW15	16	M2.5
CRB2BW20	24.5	M3
CRB2BW30	34.5	M4
CRB2BW40	39.5	M4

* Only the size 10 actuators have different L dimensions for single and double vane.
Double vane: L = 20.5
* Refer to page 56 for Q1 and Q2 dimensions.

Chamfered Position and Rotation Range: Top View from Long Shaft Side

Chamfered positions shown below illustrate the conditions of actuators when B port is pressurized.

Single vane type

Double vane type

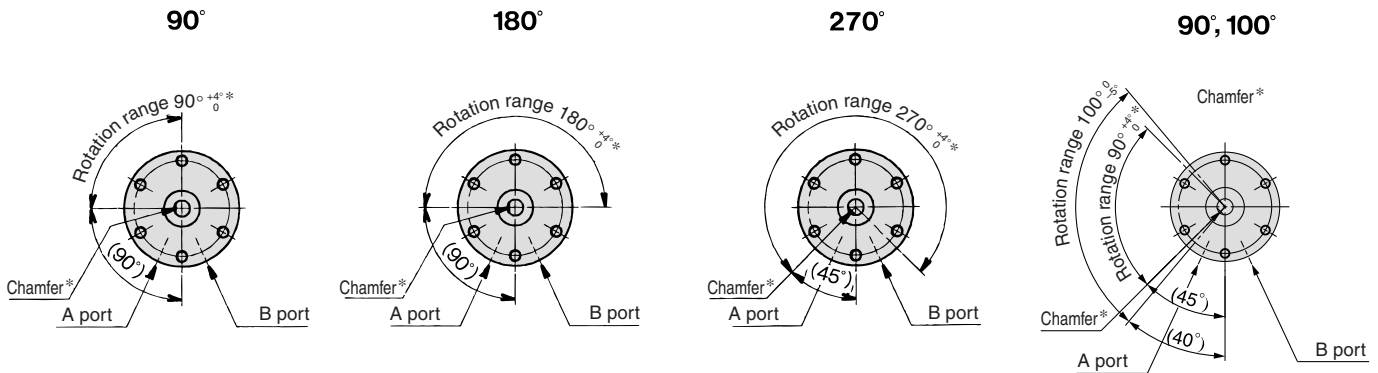

* For size 40 actuators, a parallel keyway will be used instead of chamfer.



Note 1) For single vane type, rotation tolerance of 90°, 180°, and 270° actuators will be $^{+5}_{0}$ for size 10 actuators only.
For double vane style, the tolerance of rotation angle of 90° will be $^{+5}_{0}$ for size 10 only.
Note 2) The chamfered position of the double vane type shows the 90° specification position.

- CRB2
- CRBU2
- CRB1
- MSU
- CRJ
- CRA1
- CRQ2
- MSQ
- MSZ
- CRQ2X
- MSQX
- MRQ

D-□

Construction (With auto switch unit)

Single vane type • Following figures show actuators for 90° and 180° when B port is pressurized.

(Same switch units are used for both single and double vane types.)

Double vane type • Following figures show the intermediate rotation position when A or B port is pressurized.

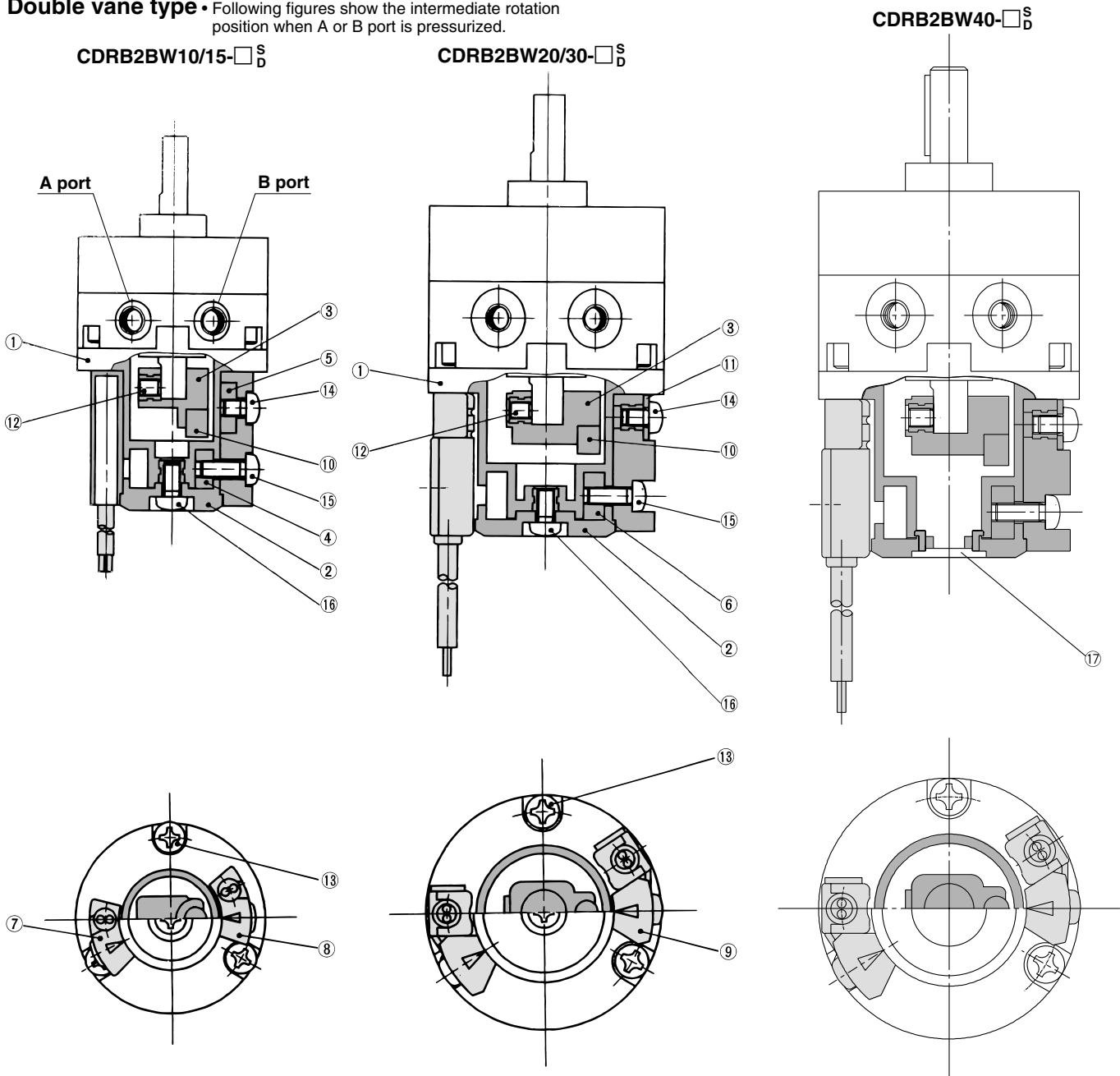

CRB2

CRBU2

CRB1

MSU

CRJ

CRA1

CRQ2

MSQ

MSZ

CRQ2X
MSQX

MRQ

Component Parts

No.	Description	Material
1	Cover (A)	Resin
2	Cover (B)	Resin
3	Magnet lever	Resin
4	Holding block (A)	Aluminum alloy
5	Holding block (B)	Aluminum alloy
6	Holding block	Aluminum alloy
7	Switch block (A)	Resin
8	Switch block (B)	Resin
9	Switch block	Resin
10	Magnet	—

No.	Description	Material
11	Arm	Stainless steel
12	Hexagon socket head set screw	Stainless steel
13	Round head Phillips screw	Stainless steel
14	Round head Phillips screw	Stainless steel
15	Round head Phillips screw	Stainless steel
16	Round head Phillips screw	Stainless steel
17	Rubber cap	NBR

* For CDRB2BW10, 2 round head Phillips screws, ⑬, are required.

D-□

Series CRB2

Dimensions: 10, 15, 20, 30

Single vane type • Following figures show actuators for 90° and 180° when B port is pressurized.

CRB2BW□-□S

<Port location: Side ported>

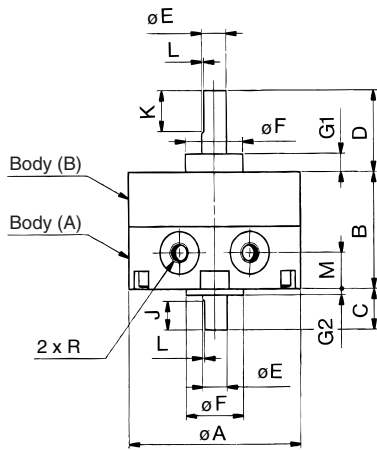
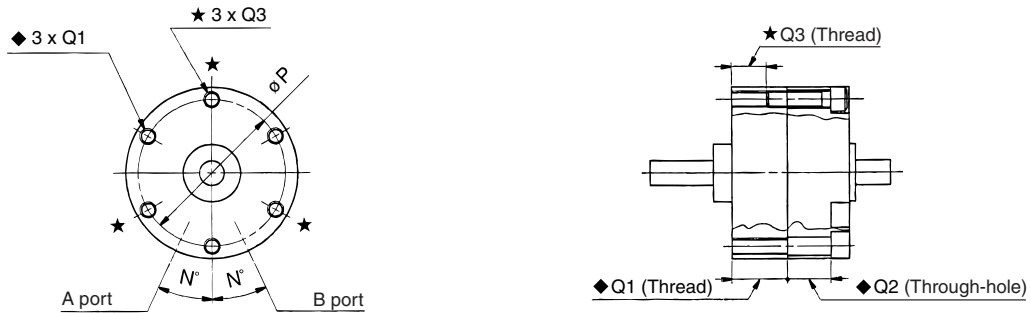

CRB2BW10-□S
<Port location: Side ported>

CRB2BW□-□SE
<Port location: Axial ported>

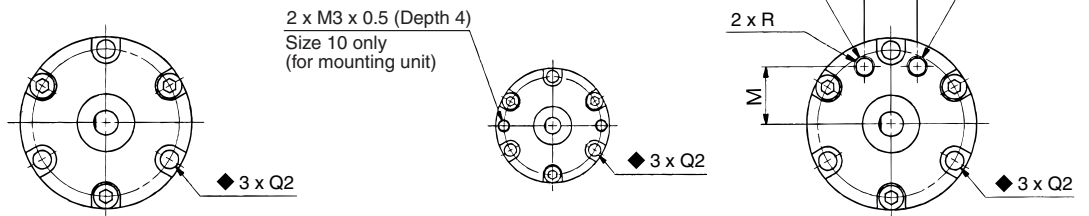

Note) Depths of Q1 and Q2 with the ◆ mark indicate that the holes go through both bodies (A) and (B).

Note) The pre-drilled mounting threads for CRB2BW15, 20, and 30, 3 mounting holes depicted with the ★ marks are for tightening the actuator and not to be used for external mounting.

Model	A	B	C	D	E(g6)	F(h9)	G1	G2	J	K	L	M	N	P	Q (Depth)			R (mm)		
															◆Q1	◆Q2	★Q3	90°	180°	270°
CRB2BW10-□S	29	15	8	14	4 ^{-0.004} _{-0.012}	9 ⁰ _{-0.036}	3	1	5	9	0.5	5	25	24	M3	3.4	—	M5	M3	
CRB2BW10-□SE												8.5	9.5		(6)	(5.5)	M3	M3		
CRB2BW15-□S	34	20	9	18	5 ^{-0.004} _{-0.012}	12 ⁰ _{-0.043}	4	1.5	6	10	0.5	5	25	29	M3	3.4	M3	M5	M3	
CRB2BW15-□SE												11	10		(6)	(5)	M3	M3		
CRB2BW20-□S	42	29	10	20	6 ^{-0.004} _{-0.012}	14 ⁰ _{-0.043}	4.5	1.5	7	10	0.5	9	25	36	M4	4.5	M4	M5		
CRB2BW20-□SE												14	13		(13.5)	(11)	(7.5)	M5		
CRB2BW30-□S	50	40	13	22	8 ^{-0.005} _{-0.014}	16 ⁰ _{-0.043}	5	2	8	12	1.0	10	25	43	M5	5.5	M5	M5		
CRB2BW30-□SE												15.5	14		(18)	(16.5)	(10)	M5		

Dimensions: 10

Double vane type • Following figures show the intermediate rotation position when A or B port is pressurized.

CRB2BW10-□D

<Port location: Side ported>

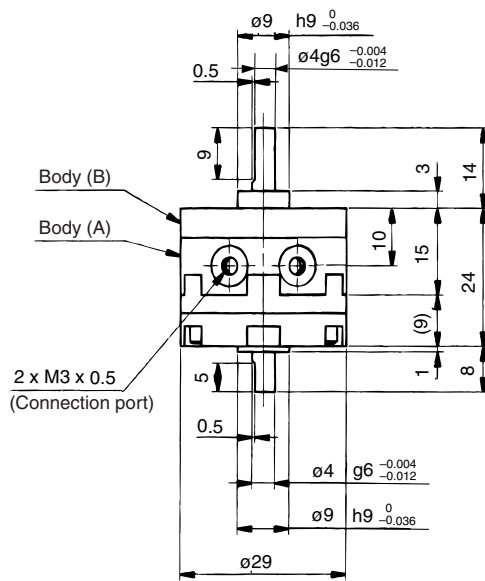
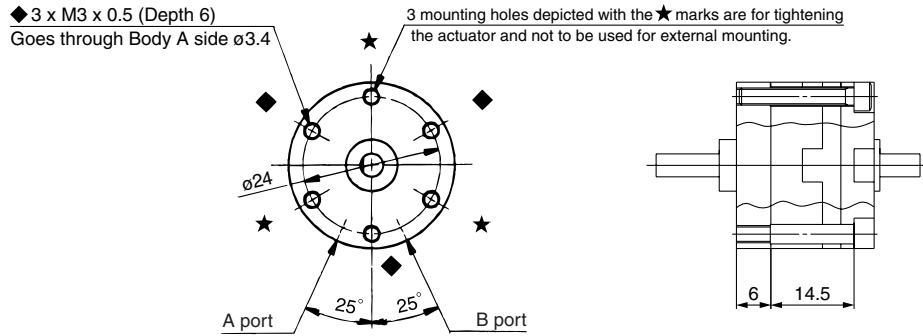

CRB2BW10-□DE
<Port location: Axial ported>

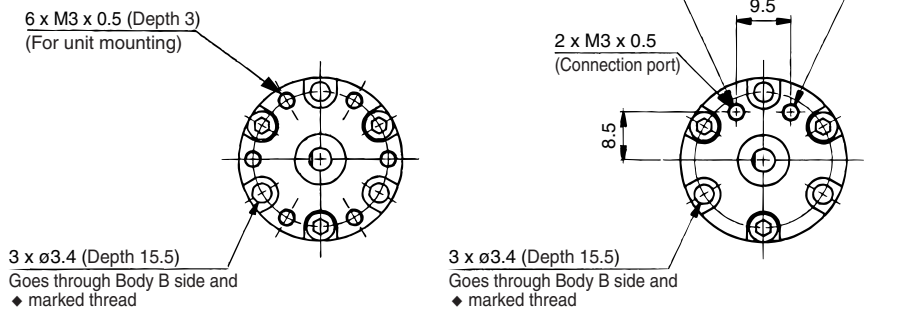

CRB2

CRBU2

CRB1

MSU

CRJ

CRA1

CRQ2

MSQ

MSZ

CRQ2X

MSQX

MRQ

D-□

Series CRB2

Dimensions: 15, 20, 30

Double vane type • Following figures show the intermediate rotation position when A or B port is pressurized.

CRB2BW15/20/30-□D <Port location: Side ported>

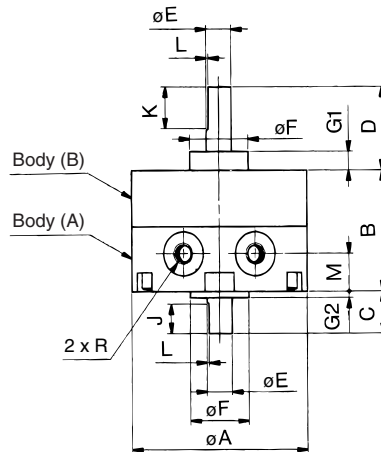
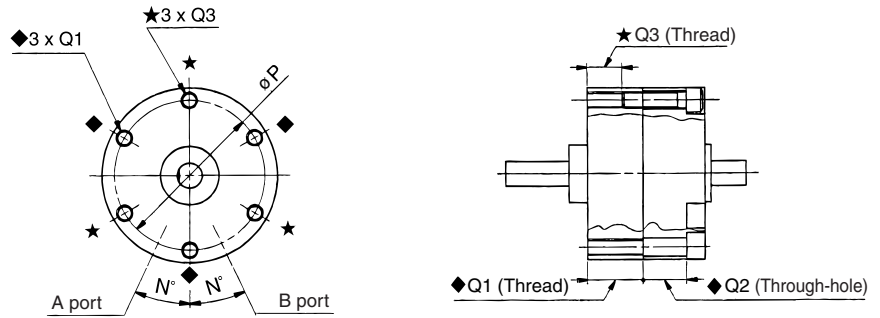

CRB2BW15/20/30-□DE <Port location: Axial ported>

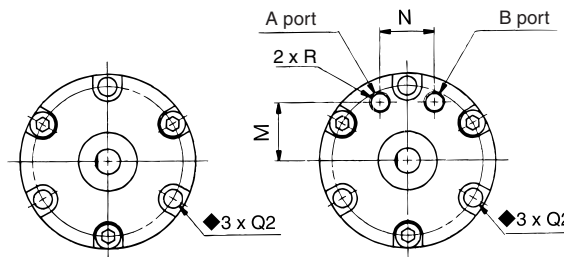

Model	A	B	C	D	E (g6)	F (h9)	G1	G2	J	K	L	M	N	P	Q (Depth)			R	
															◆Q1	◆Q2	★Q3	90°	100°
															(mm)	(mm)	(mm)	(mm)	(mm)
CRB2BW15-□D	34	20	9	18	5 ^{-0.004} _{-0.012}	12 ⁰ _{-0.043}	4	1.5	6	10	0.5	5	25	29	M3	3.4	M3	M3	
CRB2BW15-□DE												11	10		M3 (10)	(6)	(5)		
CRB2BW20-□D	42	29	10	20	6 ^{-0.004} _{-0.012}	14 ⁰ _{-0.043}	4.5	1.5	7	10	0.5	9	25	36	M4	4.5	M4	M5	
CRB2BW20-□DE												14	13		M4 (13.5)	(11)	(7.5)		
CRB2BW30-□D	50	40	13	22	8 ^{-0.005} _{-0.014}	16 ⁰ _{-0.043}	5	2	8	12	1.0	10	25	43	M5	5.5	M5	M5	
CRB2BW30-□DE												15.5	14		M5 (18)	(16.5)	(10)		

Series CDRB2

Dimensions: 10, 15, 20, 30 (With auto switch unit)

Single vane type • Following figures show actuators for 90° and 180° when B port is pressurized.

CDRB2BW10/15-□S

CDRB2BW20/30-□S

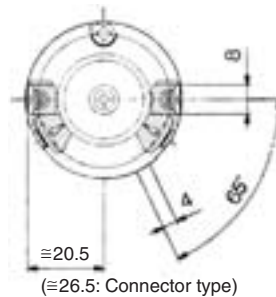
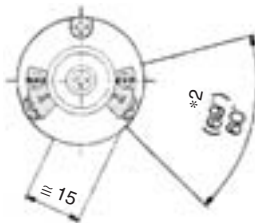
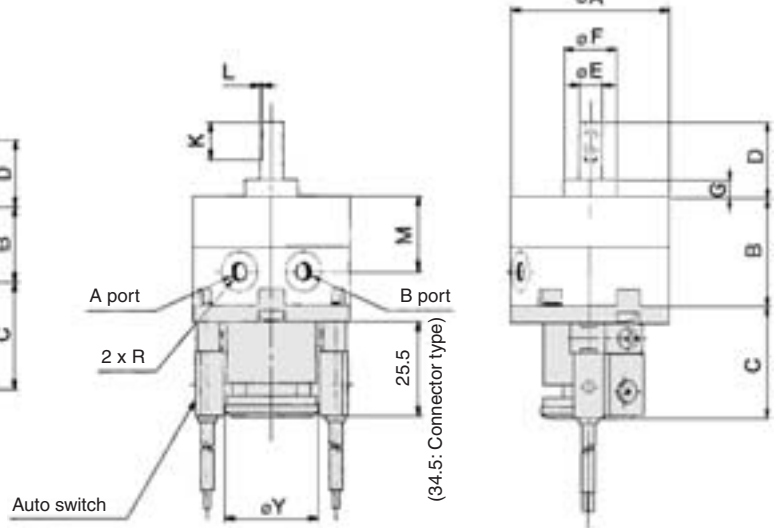
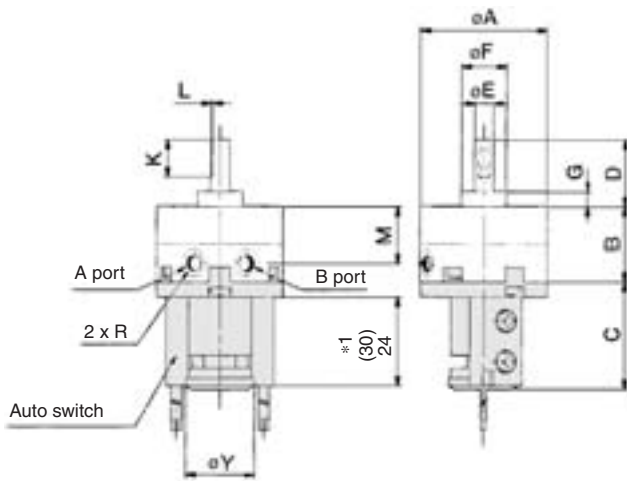
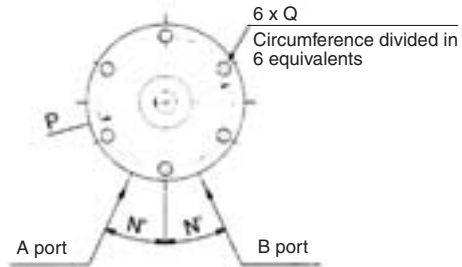
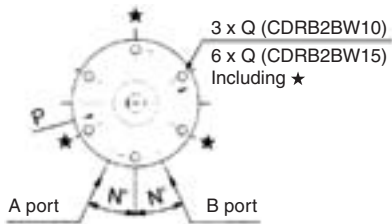

* 1 The length is 24 when any of the following auto switches are used: D-90/90A/S99(V)/T99(V)/S9P(V)

The length is 30 when any of the following auto switches are used: D-97/93A

* 2 The angle is 60° when any of the following auto switches are used: D-90/90A/97/93A

The angle is 69° when any of the following auto switches are used: D-S99(V)/T99(V)/S9P(V)

Note) For rotary actuators with auto switch unit, connection ports are side ports only.

* The above exterior view drawings illustrate rotary actuators with one right-hand and one left-hand switch.

(mm)

Model	A	B	C	D	E (g6)	F (h9)	G	K	L	M	N	P	Q	R			Y
														90°	180°	270°	
CDRB2BW10-□S	29	15	29	14	4	9	3	9	0.5	10	25	24	M3 x 0.5 depth 5	M5 x 0.8	M3 x 0.5	18.5	
CDRB2BW15-□S	34	20	29	18	5	12	4	10	0.5	15	25	29	M3 x 0.5 depth 5	M5 x 0.8	M3 x 0.5	18.5	
CDRB2BW20-□S	42	29	30	20	6	14	4.5	10	0.5	20	25	36	M4 x 0.7 depth 7	M5 x 0.8		25	
CDRB2BW30-□S	50	40	31	22	8	16	5	12	1	30	25	43	M5 x 0.8 depth 10	M5 x 0.8		25	

Dimensions: 10, 15, 20, 30 (With auto switch unit)

Double vane type • Figures below show the intermediate rotation position when A or B port is pressurized.

CDRB2BW10-□D

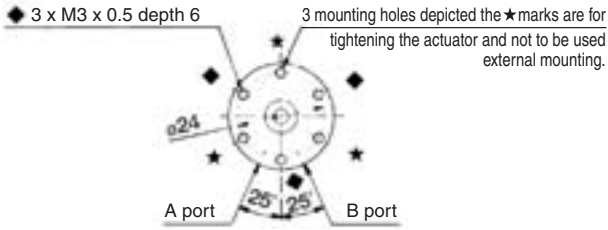

CDRB2BW15/20/30-□D

(Dimensions are the same as the single vane type.)

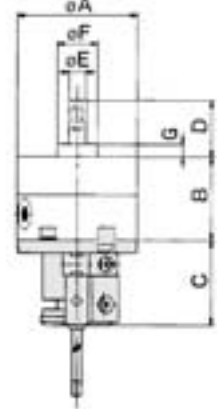
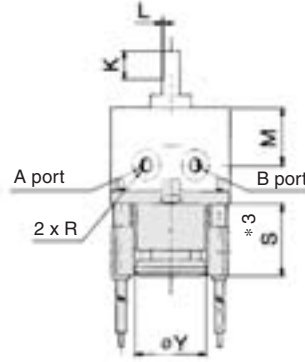
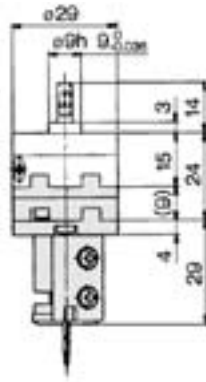
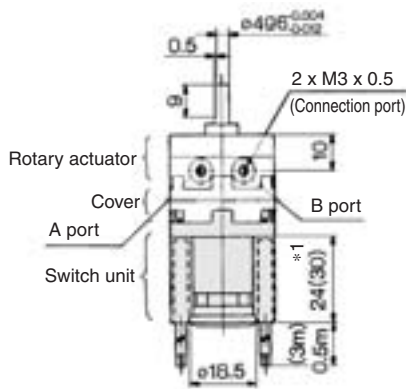
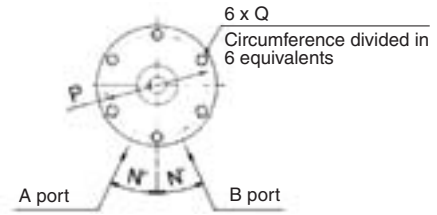

CDRB2BW15-□D

CDRB2BW20/30-□D

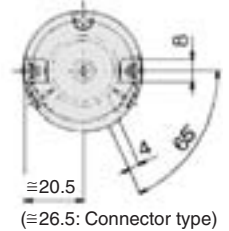
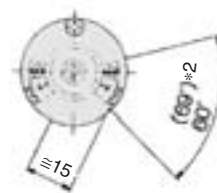
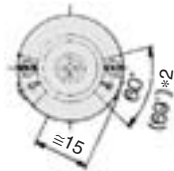

* 1 The length is 24 when any of the following auto switches are used: D-90/90A/S99(V)/T99(V)/S9P(V)

The length is 30 when any of the following auto switches are used: D-97/93A

* 2 The angle is 60° when any of the following auto switches are used: D-90/90A/97/93A

The angle is 69° when any of the following auto switches are used: D-S99(V)/T99(V)/S9P(V)

* 3 The length (Dimension S) is 25.5 when any of the following grommet type auto switches are used: D-R73/R80/S79/T79/S7P

The length (Dimension S) is 34.5 when any of the following connector type auto switches are used: D-R73/R80/T79

Model	A	B	C	D	E (g6)	F (h9)	G	K	L	M	N	P	Q	R		S		Y
														90°	100°	24 ^{*1}	30 ^{*1}	
CDRB2BW15-□D	34	20	29	18	5	12	4	10	0.5	15	25	29	M3 x 0.5 depth 5	M3 x 0.5	24 ^{*1}	30 ^{*1}	18.5	
CDRB2BW20-□D	42	29	30	20	6	14	4.5	10	0.5	20	25	36	M4 x 0.7 depth 7	M5 x 0.8	25.5 ^{*3}	34.5 ^{*3}	25	
CDRB2BW30-□D	50	40	31	22	8	16	5	12	1	30	25	43	M5 x 0.8 depth 10	M5 x 0.8			25	

(mm)

CRB2

CRBU2

CRB1

MSU

CRJ

CRA1

CRQ2

MSQ

MSZ

CRQ2X

MSQX

MRQ

D-□

Series CDRB2BW

Dimensions: 40 (With auto switch unit)

Single vane type/Double vane type

CDRB2BW40-□S/D

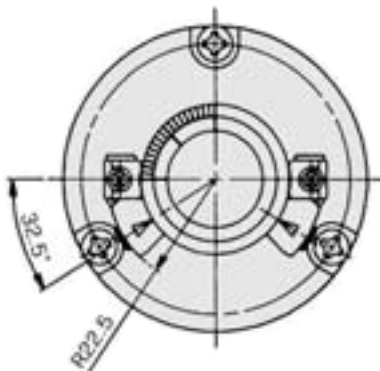
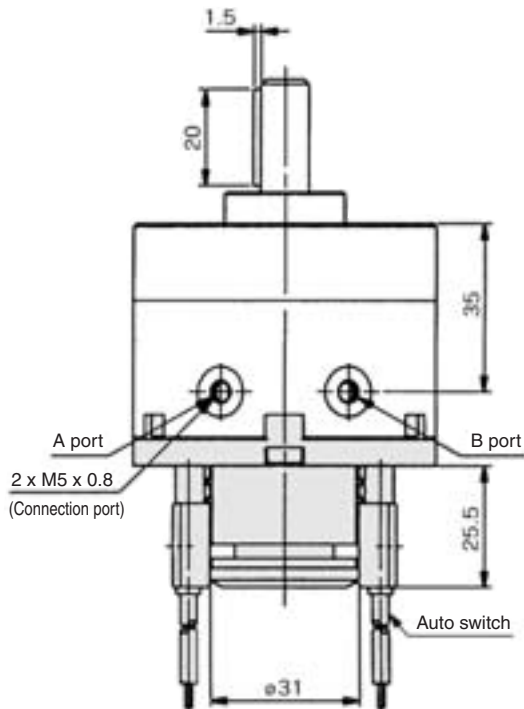
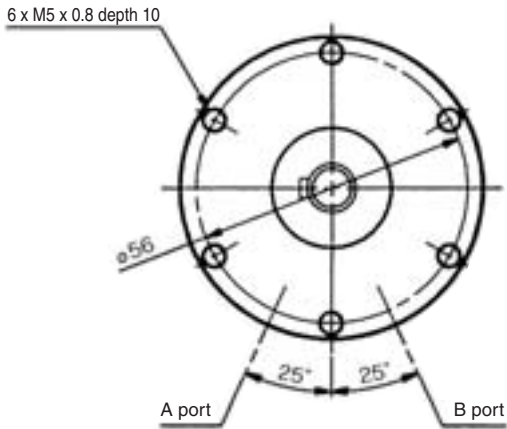

● For single vane type:

Figures show actuators for 90° and 180° when the B port is pressurized.

● For double vane type:

Figures show the intermediate rotation position when the A or B port is pressurized.

(mm)

Keyway dimensions			
	b (h9)	h (h9)	l
Series	$4_{-0.030}^0$	$4_{-0.030}^0$	20
CDRB2BW40-□□□			

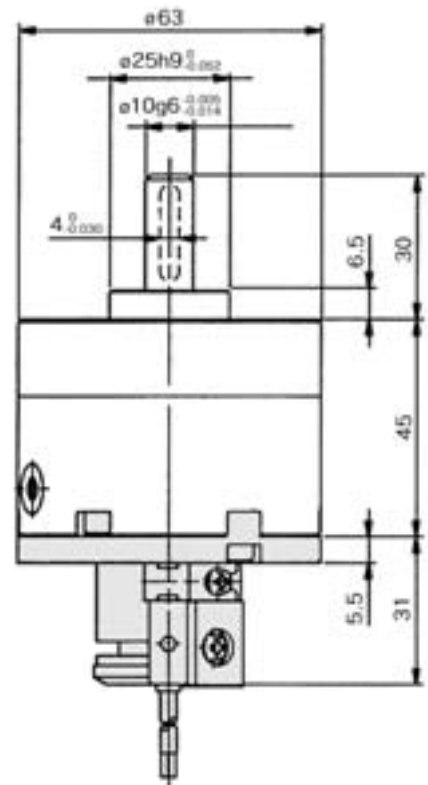

Rotary Actuator with Angle Adjuster Vane Style

Series **CRB2BWU**

Size: 10, 15, 20, 30, 40



Without auto switch

With auto switch
Size: 10, 15

With auto switch
Size: 20, 30, 40

With auto switch
(With auto switch unit and built-in magnet)
* Refer to page 141 when the auto switch unit is needed separately.



CRB2 **B** WU

CDRB2 **F** WU

CDRB2 **B** WU

Mounting style

B	Basic style
F	Flange style

* F: Except size 40

With angle adjuster

Pattern

Nil	Standard
P	Simple Specials/Made to Order

* For details, refer to pages 69 to 80.

How to Order

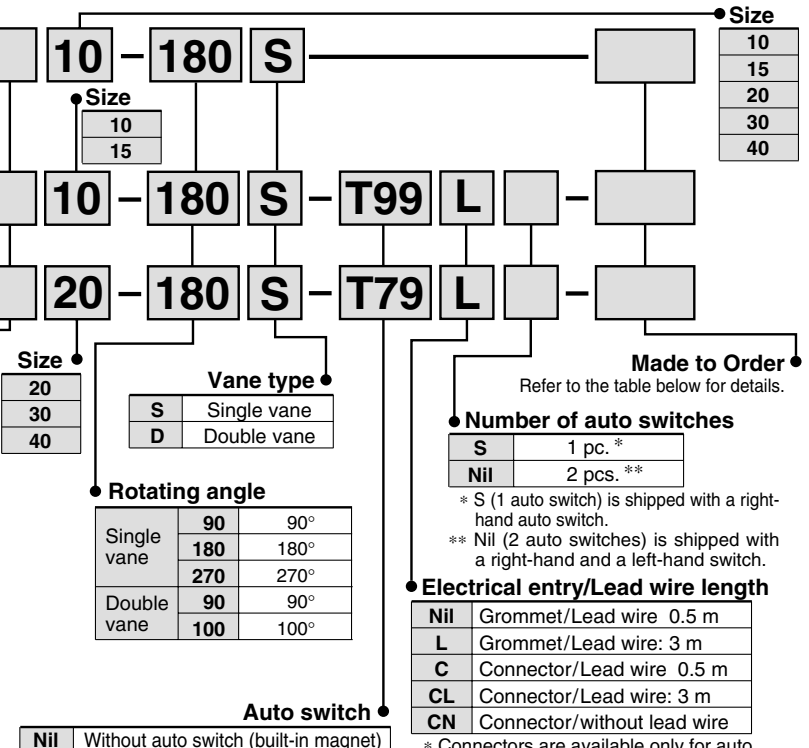

Number of auto switches

S	1 pc. *
Nil	2 pcs. **

* S (1 auto switch) is shipped with a right-hand auto switch.
** Nil (2 auto switches) is shipped with a right-hand and a left-hand switch.

Electrical entry/Lead wire length

Nil	Grommet/Lead wire	0.5 m
L	Grommet/Lead wire	3 m
C	Connector/Lead wire	0.5 m
CL	Connector/Lead wire	3 m
CN	Connector/without lead wire	

* Connectors are available only for auto switch types R73, R80 and T79.
* Lead wire with connector part nos.
D-LC05: Lead wire 0.5 m
D-LC30: Lead wire 3 m
D-LC50: Lead wire 5 m

Applicable Auto Switches/Refer to pages 761 to 809 for further information on auto switches.

Applicable size	Type	Electrical entry	Indicator light	Wiring (Output)	Load voltage		Auto switch model	Lead wire type	Lead wire length (m) *				Applicable load							
					DC	AC			0.5 (Nil)	3 (L)	5 (Z)	None (N)								
For 10 and 15	Solid state switch	Grommet	Yes	2-wire	24V	12V	—	Heavy-duty cord	●	●	—	—	IC circuit	Relay, PLC						
									●	●	—	—								
									●	●	—	—								
									●	●	—	—								
									●	●	—	—								
	Reed switch	Grommet	No	2-wire	24V	5V, 12V	24 V or less 100 V or less	Parallel cord	●	●	●	—	IC circuit	Relay, PLC						
									●	●	●	—								
									●	●	●	—								
For 20, 30 and 40	Solid state switch	Grommet	Yes	2-wire	24V	12V	—	Heavy-duty cord	●	●	●	●	IC circuit	Relay, PLC						
									●	●	●	●								
		Connector		Grommet					3-wire (NPN)	5V, 12V	—	—			—	—	●	●	—	—
																	●	●	—	—
	Reed switch	Grommet	Yes	2-wire	24V	—	100V	Parallel cord	●	●	—	—	IC circuit	Relay, PLC						
									●	●	—	—								
		Connector	Grommet						No	48V, 100V	100 V or less	—			—	—	●	●	●	●
																	●	●	●	●
Connector	Grommet	No	2-wire	24V	—	24 V or less	Parallel cord	●	●	●	●	IC circuit	Relay, PLC							
								●	●	●	●									

* Lead wire length symbols: 0.5 m Nil (Example) R73C
3 m L (Example) R73CL
5 m Z (Example) R73CZ
None N (Example) R73CN

Made to Order
(Refer to pages 69 to 73, 79 and 80 for details.)

Symbol	Specifications/Description
XA1 to XA24	Shaft type pattern
XC 1	Add connection port
XC 2	Change threaded hole to through-hole
XC 3	Change the screw position
XC 4	Change rotation range
XC 5	Change rotation range between 0 and 200°
XC 6	Change rotation range between 0 and 110°
XC 7	Reversed shaft
XC30	Fluorine grease

The above may not be selected when the product comes with an auto switch or angle adjustment unit. Refer to pages 69, 70 and 79 for details.

CRB2

CRBU2

CRB1

MSU

CRJ

CRA1

CRQ2

MSQ

MSZ

CRQ2X
MSQX

MRQ

D-□

Series CRB2BWU

Construction (Same switch units are used for both single and double vane type.)

With angle adjuster

CRB2BWU10/15/20/30/40-□^S_D

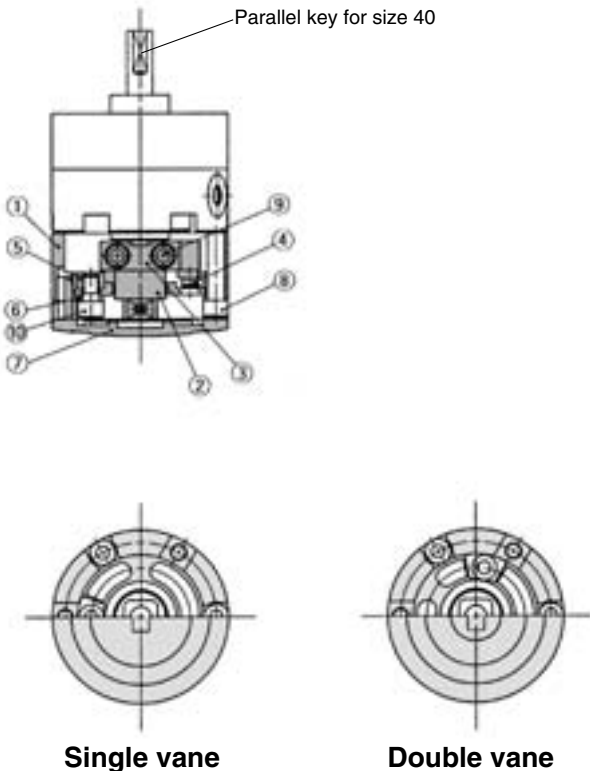

With angle adjuster + Auto switch unit

CDRB2BWU10/15-□^S_D

CDRB2BWU20/30/40-□^S_D

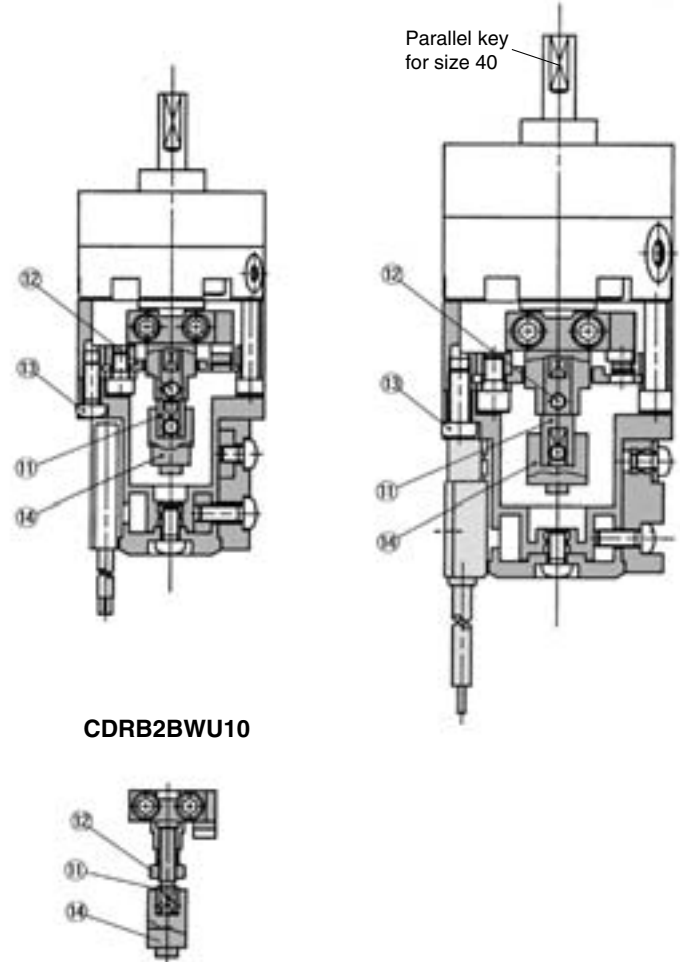

Component Parts

No.	Description	Material	Note
1	Stopper ring	Aluminum die-casted	Electroless nickel plated
2	Stopper lever	Carbon steel	Electroless nickel plated
3	Lever retainer	Carbon steel	Zinc chromated
4	Rubber bumper	NBR	
5	Stopper block	Carbon steel	Zinc chromated
6	Block retainer	Carbon steel	Zinc chromated
7	Cap	Resin	
8	Hexagon socket head cap screw	Stainless steel	Special screw
9	Hexagon socket head cap screw	Stainless steel	Special screw
10	Hexagon socket head cap screw	Stainless steel	Special screw
11	Joint	Aluminum alloy	Note) Zinc chromated
12	Hexagon socket head cap screw	Stainless steel	Hexagon nut will be used
	Hexagon nut	Stainless steel	for size 10 only.
13	Round head Phillips screw	Stainless steel	Note)
14	Magnet lever	—	Note)

Note) These items (No. 11, 13, and 14) consist of auto switch unit and angle adjuster. Refer to pages 140 and 141 for detailed specifications. Stainless steel is used for size 10 only.

⚠ Precautions

Be sure to read before handling. Refer to front matters 38 and 39 for Safety Instructions and pages 4 to 13 for Rotary Actuator and Auto Switch Precautions.

Angle Adjuster

⚠ Caution

1. Since the maximum angle of the rotation adjustment range will be limited by the rotation of the rotary actuator itself, make sure to take this into consideration when ordering.

Rotating angle of the rotary actuator	Rotating angle adjustment range
270° ⁺⁴ ₀	0° to 230° (Size: 10, 40) *1 0° to 240° (Size: 15, 20, 30)
180° ⁺⁴ ₀	0° to 175°
90° ⁺⁴ ₀	0° to 85°

*1 The maximum adjustment angle of the angle adjuster for size 10 and 40 is 230°.

- Connection ports are side ports only.
- The allowable kinetic energy is the same as the specifications of the rotary actuator by itself (i.e., without angle adjuster).
- Use a 100° rotary actuator if you desire to adjust the angle to 90° using a double vane type.

Dimensions: 10, 15, 20, 30 (With angle adjuster)

Single vane type
CRB2BWU10/15/20/30-□S

• Following figures show actuator for 90° when A port is pressurized.

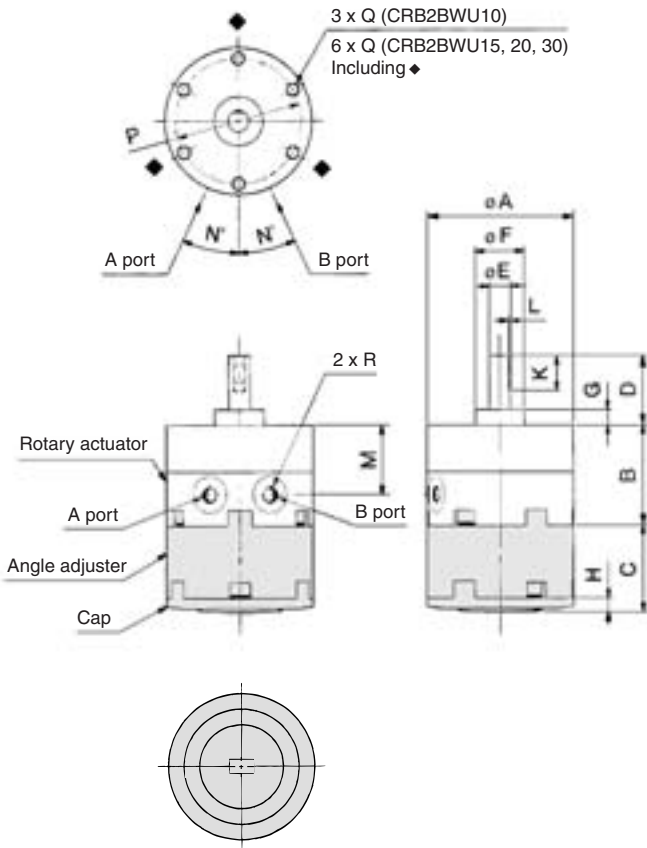

Double vane type
CRB2BWU10-□D

• Following figures show the intermediate rotation position when A or B port is pressurized.

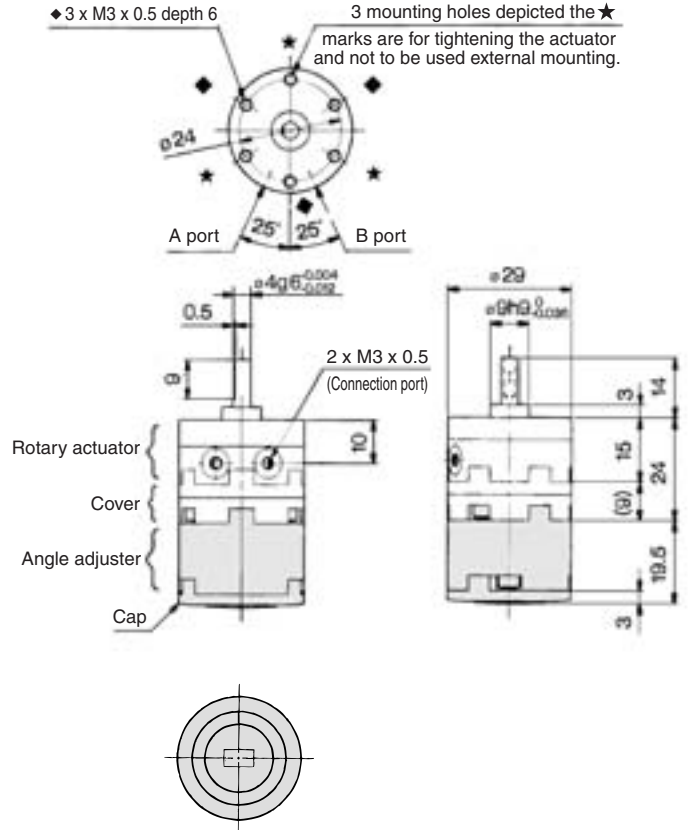

Double vane type
CRB2BWU15/20/30-□D

Dimensions for double vane type sizes 15, 20, and 30 are the same as those of single type.

- CRB2
- CRBU2
- CRB1
- MSU
- CRJ
- CRA1
- CRQ2
- MSQ
- MSZ
- CRQ2X
- MSQX
- MRQ

Model	(mm)													
	A	B	C	D	E (g6)	F (h9)	G	H	K	L	M	N	P	Q
CRB2BWU10-□S	29	15	19.5	14	4	9	3	3	9	0.5	10	25	24	M3 x 0.5 depth 6
CRB2BWU15-□S	34	20	21.2	18	5	12	4	3.2	10	0.5	15	25	29	M3 x 0.5 depth 5
CRB2BWU15-□D														
CRB2BWU20-□S	42	29	25	20	6	14	4.5	4	10	0.5	20	25	36	M4 x 0.7 depth 7
CRB2BWU20-□D														
CRB2BWU30-□S	50	40	29	22	8	16	5	4.5	12	1	30	25	43	M5 x 0.8 depth 10
CRB2BWU30-□D														

Model	R			
	90°	100°	180°	270°
CRB2BWU10-□S	M5 x 0.8	—	M5 x 0.8	M3 x 0.5
CRB2BWU10-□D	*Refer to the drawing.			
CRB2BWU15-□S	M5 x 0.8	—	M5 x 0.8	M3 x 0.5
CRB2BWU15-□D	M3 x 0.5		—	
CRB2BWU20-□S	M5 x 0.8	—	M5 x 0.8	
CRB2BWU20-□D	M5 x 0.8		—	
CRB2BWU30-□S	M5 x 0.8	—	M5 x 0.8	
CRB2BWU30-□D	M5 x 0.8		—	

D-□

Series CRB2BWU

Dimensions: 40 (With angle adjuster)

Single vane type/Double vane type
With angle adjuster

CRB2BWU40-□□S/D

● **For single vane type:**

Figures show actuators for 90° and 180° when the B port is pressurized.

● **For double vane type:**

Figures show the intermediate rotation position when the A or B port is pressurized.

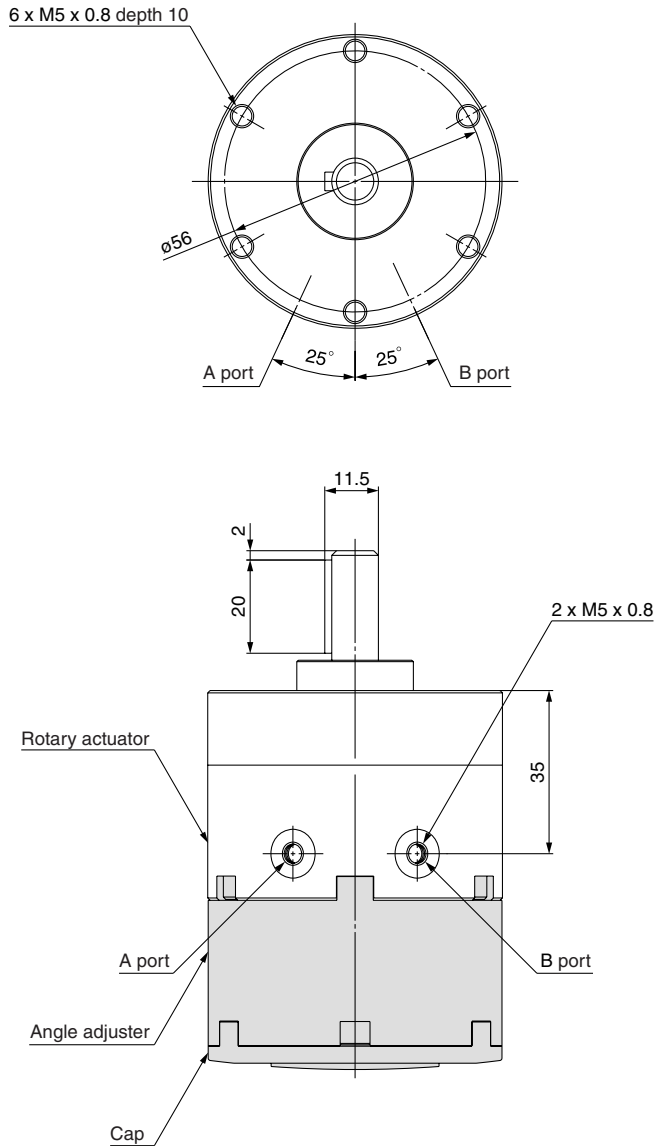

(mm)

Model	b (h9)	h (h9)	ℓ
CRB2BWU40-□□□	4 ⁰ _{-0.030}	4 ⁰ _{-0.030}	20

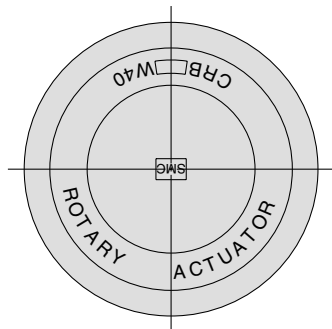
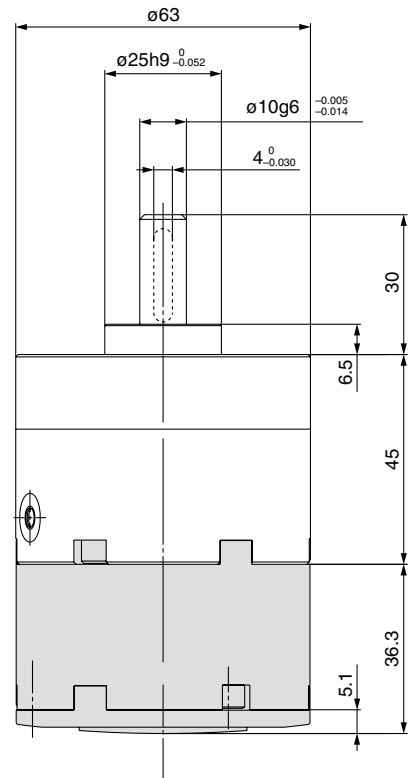

Rotary Actuator with Angle Adjuster Vane Style **Series CRB2BWU**

Dimensions: 10, 15, 20, 30 (With angle adjuster and auto switch unit)

Single vane type CDRB2BWU10/15-□S

• Following figures show actuator for 90° when A port is pressurized.

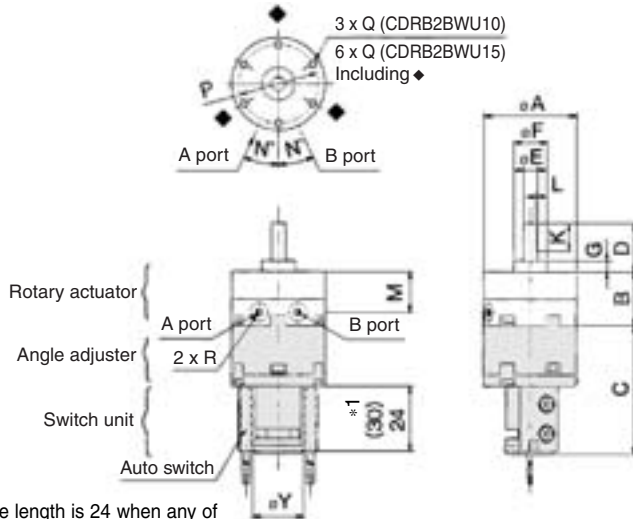

- * 1. The length is 24 when any of the following auto switches are used: D-90/90A/S99(V)/T99(V)/S9P(V). The length is 30 when any of the following auto switches are used: D-97/93A.
- * 2. The angle is 60° when any of the following auto switches are used: D-90/90A/97/93A. The angle is 69° when any of the following auto switches are used: D-S99(V)/T99(V)/S9P(V).

Double vane type CDRB2BWU10-□D

• Following figures show the intermediate rotation position when A or B port is pressurized.

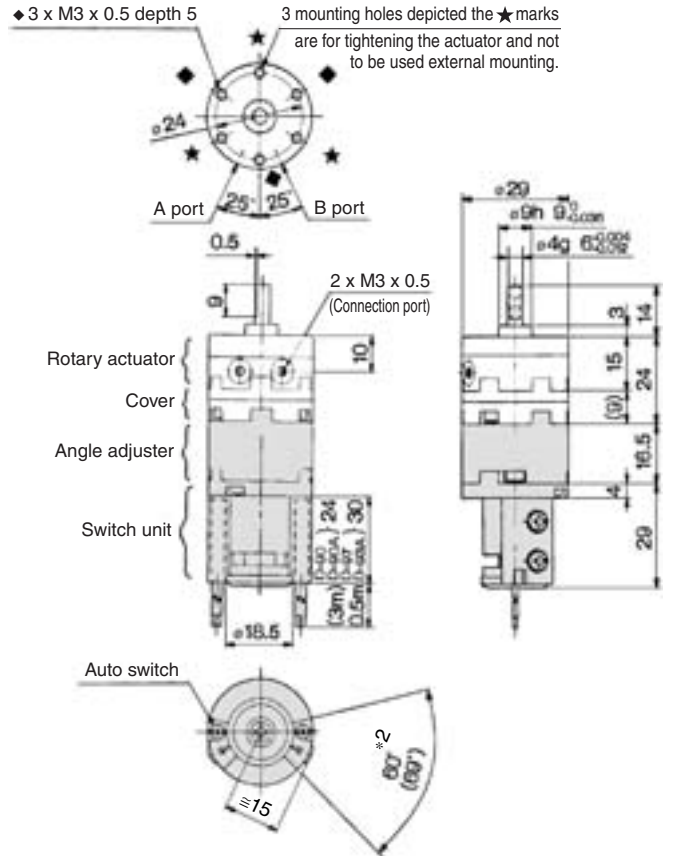

- CRB2
- CRBU2
- CRB1
- MSU
- CRJ
- CRA1
- CRQ2
- MSQ
- MSZ
- CRQ2X
- MSQX
- MRQ

Single vane type CDRB2BWU20/30-□S

6 x Q
Circumference divided in 6 equivalents

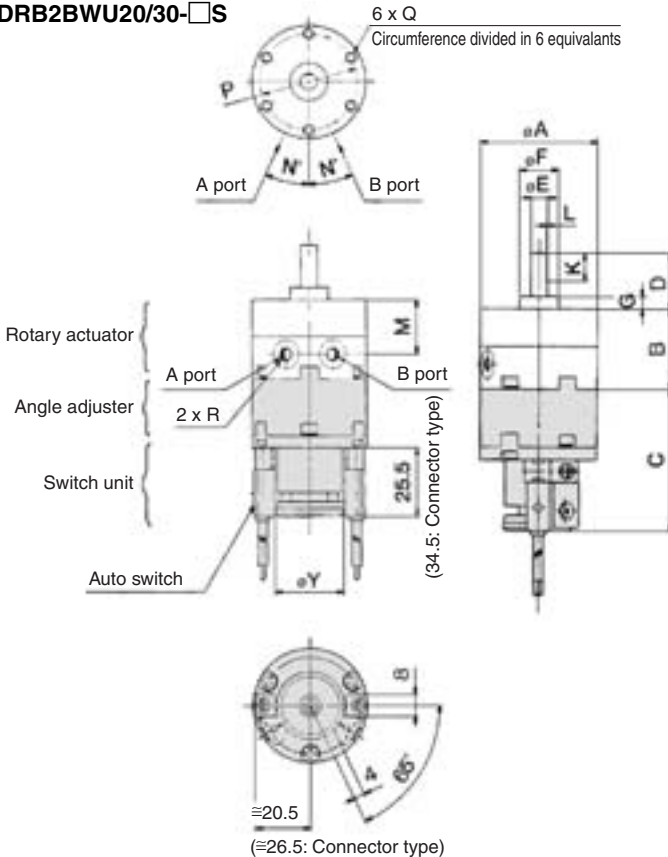

Double vane type CDRB2BWU15/20/30-□D

Dimensions for double vane type sizes 15, 20, and 30 are the same as those of single type.

Model	A	B	C	D	E (g6)	F (h9)	G	K	L	M
CDRB2BWU10-□S	29	15	45.5	14	4	9	3	9	0.5	10
CDRB2BWU15-□S	34	20	47	18	5	12	4	10	0.5	15
CDRB2BWU15-□D										
CDRB2BWU20-□S	42	29	51	20	6	14	4.5	10	0.5	20
CDRB2BWU20-□D										
CDRB2BWU30-□S	50	40	55.5	22	8	16	5	12	1	30
CDRB2BWU30-□D										

Model	N	P	Y	Q	R			
					90°	100°	180°	270°
CDRB2BWU10-□S	25	24	18.5	M3 x 0.5 depth 6	M5 x 0.8	—	M5 x 0.8	M3 x 0.5
CDRB2BWU10-□D					* Refer to the drawing.			
CDRB2BWU15-□S	25	29	18.5	M3 x 0.5 depth 5	M5 x 0.8	—	M5 x 0.8	M3 x 0.5
CDRB2BWU15-□D					M3 x 0.5	—		
CDRB2BWU20-□S	25	36	25	M4 x 0.7 depth 7	M5 x 0.8	—	M5 x 0.8	
CDRB2BWU20-□D					M5 x 0.8	—		
CDRB2BWU30-□S	25	43	25	M5 x 0.8 depth 10	M5 x 0.8	—	M5 x 0.8	
CDRB2BWU30-□D					M5 x 0.8	—		

Note) • For rotary actuators with angle adjuster and auto switch unit, connection ports are side ports only.
• The above exterior view drawings illustrate the rotary actuator equipped with one right-hand and one left-hand switch.

Series CRB2BWU

Dimensions: 40 (With angle adjuster and auto switch unit)

Single vane type/Double vane type CDRB2BWU40-□S/D

6 x M5 x 0.8 depth 10

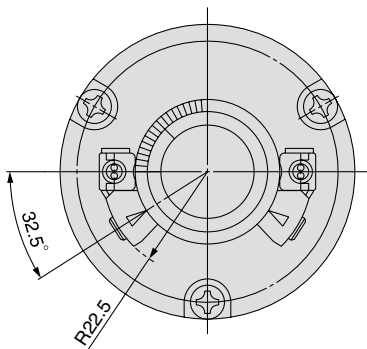
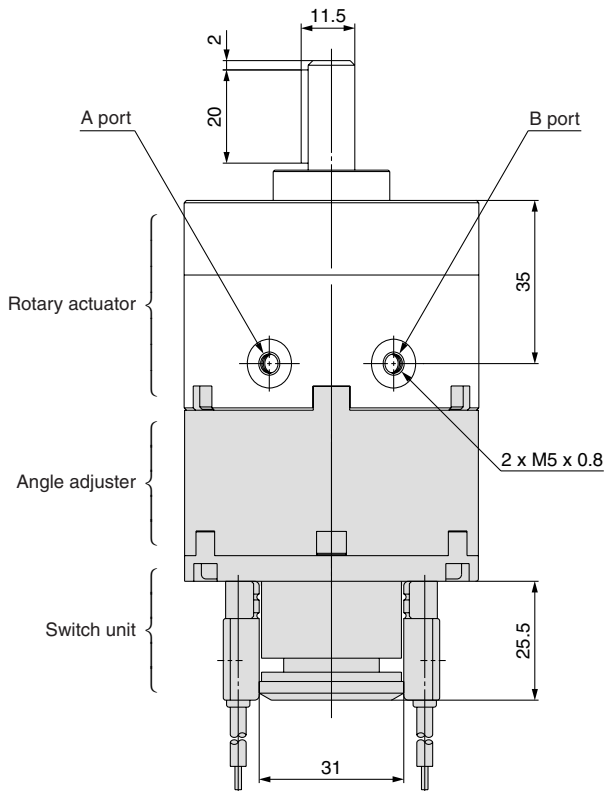
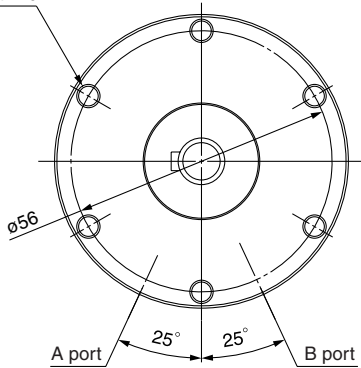

● For single vane type:

Figures show actuators for 90° and 180° when the B port is pressurized.

● For double vane type:

Figures show the intermediate rotation position when the A or B port is pressurized.

Keyway dimensions	(mm)		
	b (h9)	h (h9)	ℓ
Model	4 ⁰ _{-0.030}	4 ⁰ _{-0.030}	20
CDRB2BWU40-□□□			

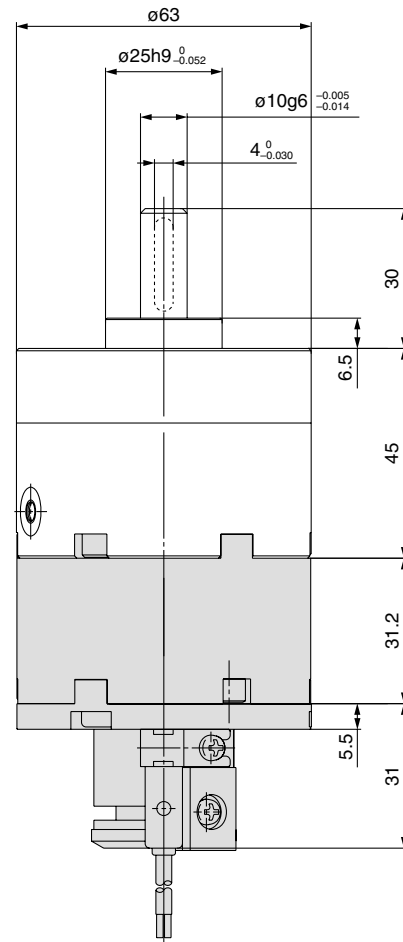

Series CRB2 (Size: 10, 15, 20, 30, 40)

Simple Specials:

-XA1 to -XA24: Shaft Pattern Sequencing I

Shaft shape pattern is dealt with simple made-to-order system. (Refer to front matter 33). Please contact SMC for a specification sheet when placing an order.

Shaft Pattern Sequencing I

-XA1 to XA24

Applicable shaft type: W (Standard)

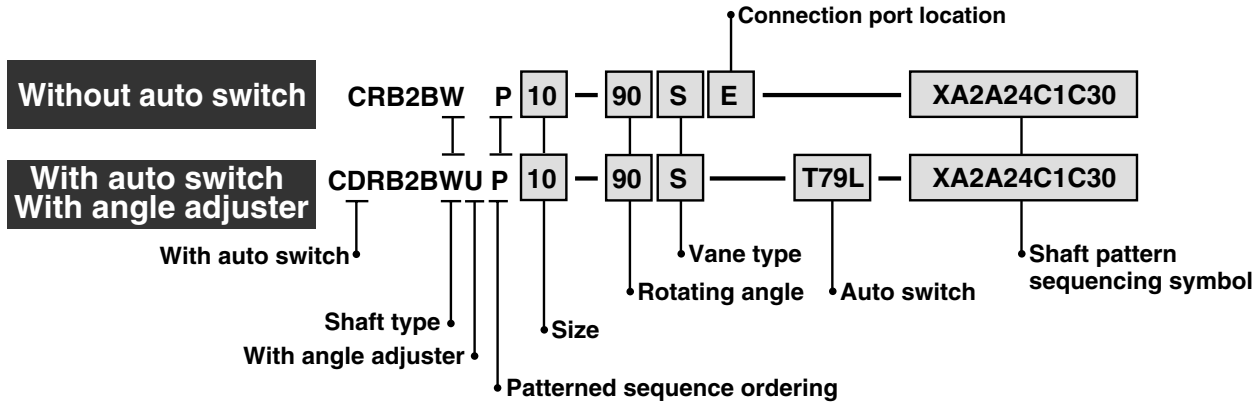

Shaft Pattern Sequencing Symbol

● Axial: Top (Long shaft side)

Symbol	Description	Applicable size				
		10	15	20	30	40
XA 1	Shaft-end female thread		●	●	●	
XA 3	Shaft-end male thread	●	●	●	●	
XA 5	Stepped round shaft	●	●	●	●	
XA 7	Stepped round shaft with male thread	●	●	●	●	
XA 9	Modified length of standard chamfer	●	●	●	●	
XA11	Two-sided chamfer	●				
XA14*	Shaft through-hole + Shaft-end female thread		●	●	●	●
XA17	Shortened shaft	●	●	●	●	
XA21	Stepped round shaft with double-sided chamfer	●	●	●	●	
XA23	Right-angle chamfer	●	●	●	●	
XA24	Double key					●

* These specifications are not available for rotary actuators with auto switch unit and angle adjuster.

● Axial: Bottom (Short shaft side)

Symbol	Description	Applicable size				
		10	15	20	30	40
XA 2*	Shaft-end female thread		●	●	●	●
XA 4*	Shaft-end male thread	●	●	●	●	●
XA 6*	Stepped round shaft	●	●	●	●	●
XA 8*	Stepped round shaft with male thread	●	●	●	●	●
XA10*	Modified length of standard chamfer	●	●	●	●	●
XA12*	Two-sided chamfer	●	●	●	●	●
XA15*	Shaft through-hole + Shaft-end female thread		●	●	●	●
XA18*	Shortened shaft	●	●	●	●	●
XA22*	Stepped round shaft with double-sided chamfer	●	●	●	●	●

● Double Shaft

Symbol	Description	Applicable size				
		10	15	20	30	40
XA13*	Shaft through-hole		●	●	●	●
XA16*	Shaft through-hole + Double shaft-end female thread		●	●	●	●
XA19*	Shortened shaft	●	●	●	●	
XA20*	Reversed shaft	●	●	●	●	●

CRB2

CRBU2

CRB1

MSU

CRJ

CRA1

CRQ2

MSQ

MSZ

CRQ2X

MSQX

MRQ

D-□

Series CRB2

Combination

XA□ Combination

Symbol	Combination																									
XA 1	XA1																									
XA 2	●	XA2																								
XA 3	—	●	XA3																							
XA 4	●	—	●	XA4																						
XA 5	—	●	—	●	XA5																					
XA 6	●	—	●	—	●	XA6																				
XA 7	—	●	—	●	—	●	XA7																			
XA 8	●	—	●	—	●	—	●	XA8																		
XA 9	—	●	—	●	—	●	—	●	XA9																	
XA10	●	—	●	—	●	—	●	—	●	XA10																
XA11	—	●	—	●	—	●	—	●	—	●	XA11															
XA12	●	—	●	—	●	—	●	—	●	—	●	XA12														
XA13	—	—	—	—	—	—	—	—	—	—	●	●	XA13													
XA14	—	—	—	—	—	—	—	—	—	—	●	●	—	XA14												
XA15	—	—	—	—	—	—	—	—	—	—	●	●	—	—	XA15											
XA16	—	—	—	—	—	—	—	—	—	—	—	—	—	—	●	XA16										
XA17	—	●	—	●	—	●	—	●	—	●	—	●	—	●	—	●	XA17									
XA18	●	—	●	—	●	—	●	—	●	—	●	—	●	—	●	—	●	XA18								
XA19	—	—	—	—	—	—	—	—	—	—	—	—	—	—	●	—	—	XA19								
XA20	—	—	—	—	—	—	—	—	—	—	—	—	—	—	—	—	—	—	XA20							
XA21	—	●	—	●	—	●	—	●	—	●	—	●	—	●	—	●	—	●	—	●	XA21					
XA22	●	—	●	—	●	—	●	—	●	—	●	—	●	—	●	—	●	—	●	—	●	XA22				
XA23	—	●	—	●	—	●	—	●	—	●	—	●	—	●	—	●	—	●	—	●	—	●	—	●	—	●
XA24	—	●	—	●	—	●	—	●	—	●	—	●	—	●	—	●	—	●	—	●	—	●	—	●	—	●

A combination of up to two XA□s are available.

Example: -XA2A24

XA□, XC□ Combination

Combination other than -XA□, such as Made to Order (-XC□), is also available.

Refer to pages 79 to 80 for details of made-to-order specifications.

Symbol	Description	Applicable size	Combination
			XA1 to XA24
XC 1*	Add connection port location	10, 15, 20, 30, 40	●
XC 2*	Change threaded hole to through-hole	15, 20, 30, 40	●
XC 3*	Change the screw position	10, 15, 20, 30, 40	●
XC 4	Change rotation range		●
XC 5*	Change rotation range between 0 to 200°		●
XC 6*	Change rotation range between 0 to 110°		●
XC 7*	Reversed shaft		—
XC30	Fluorine grease		●

* These specifications are not available for rotary actuators with auto switch unit and angle adjuster.

A total of four XA□ and XC□ combinations is available.

Example: -XA2A24C1C30

-XA2C1C4C30

Axial: Top (Long shaft side)

Symbol: A1 The long shaft can be further shortened by machining female threads into it.

- (If shortening the shaft is not required, indicate "*" for dimension X.)
- Not available for size 10.
 - The maximum dimension L1 is, as a rule, twice the thread size. (Example) For M3: L1 = 6 mm
 - Applicable shaft type: W

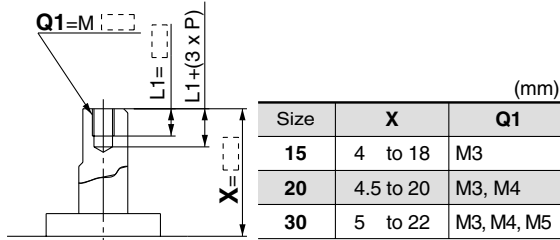

Symbol: A3 The long shaft can be further shortened by machining male threads into it.

- (If shortening the shaft is not required, indicate "*" for dimension X.)
- Applicable shaft type: W

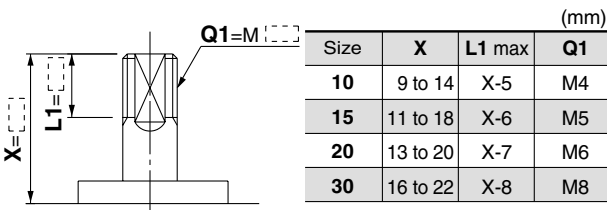

Symbol: A5 The long shaft can be further shortened by machining it into a stepped round shaft.

- (If shortening the shaft is not required, indicate "*" for dimension X.)
- Applicable shaft type: W
 - Equal dimensions are indicated by the same marker. (If not specifying dimension C1, indicate "*" instead.)

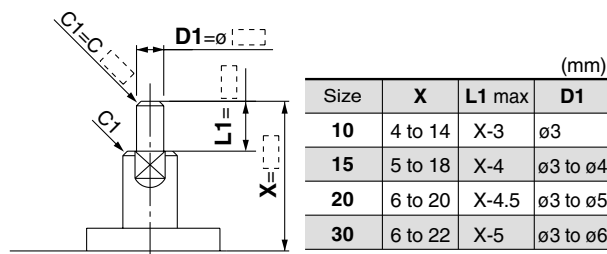

Symbol: A7 The long shaft can be further shortened by machining it into a stepped round shaft with male threads.

- (If shortening the shaft is not required, indicate "*" for dimension X.)
- Applicable shaft type: W
 - Equal dimensions are indicated by the same marker. (If not specifying dimension C1, indicate "*" instead.)

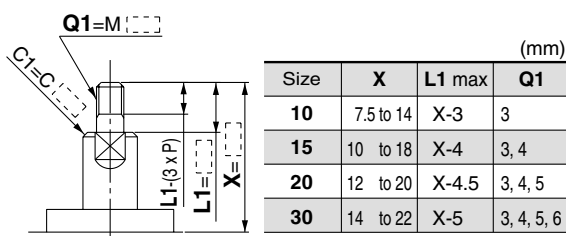

Axial: Bottom (Short shaft side)

Symbol: A2 The short shaft can be further shortened by machining female threads into it.

- (If shortening the shaft is not required, indicate "*" for dimension Y.)
- Not available for size 10.
 - The maximum dimension L2 is, as a rule, twice the thread size. (Example) For M3: L2 = 6 mm
 - Applicable shaft type: W

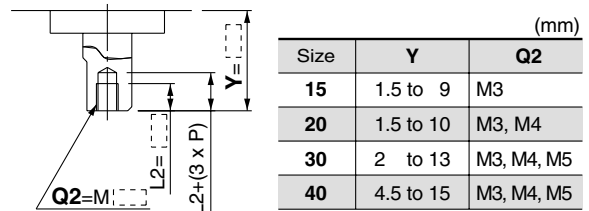

Symbol: A4 The short shaft can be further shortened by machining male threads into it.

- (If shortening the shaft is not required, indicate "*" for dimension Y.)
- Applicable shaft type: W

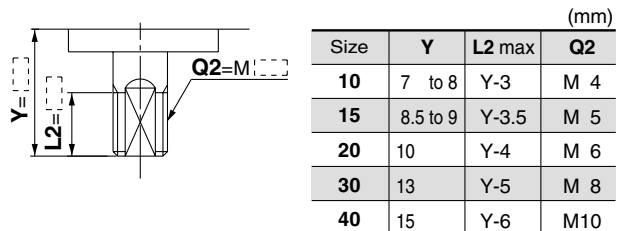

Symbol: A6 The short shaft can be further shortened by machining it into a stepped round shaft.

- (If shortening the shaft is not required, indicate "*" for dimension Y.)
- Applicable shaft type: W
 - Equal dimensions are indicated by the same marker. (If not specifying dimension C2, indicate "*" instead.)

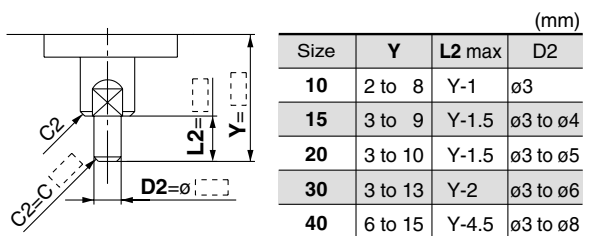

Symbol: A8 The short shaft can be further shortened by machining it into a stepped round shaft with male threads.

- (If shortening the shaft is not required, indicate "*" for dimension Y.)
- Applicable shaft type: W
 - Equal dimensions are indicated by the same marker. (If not specifying dimension C2, indicate "*" instead.)

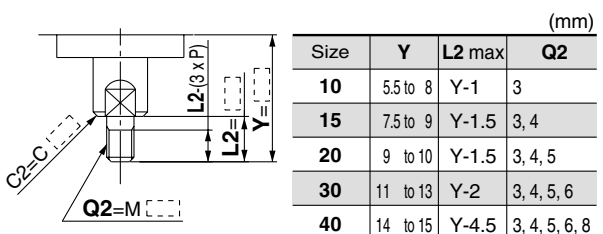

CRB2

CRBU2

CRB1

MSU

CRJ

CRA1

CRQ2

MSQ

MSZ

CRQ2X

MSQX

MRQ

D-□

Axial: Top (Long shaft side)

Symbol: A9 The long shaft can be further shortened by changing the length of the standard chamfer on the long shaft side.

(If shortening the shaft is not required, indicate "*" for dimension X.)
 ● Applicable shaft type: W

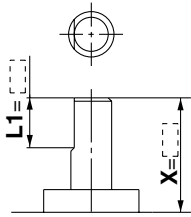

Size	X	L1
10	5 to 14	9-(14-X) to (X-3)
15	8 to 18	10-(18-X) to (X-4)
20	10 to 20	10-(20-X) to (X-4.5)
30	10 to 22	12-(22-X) to (X-5)

Symbol: A11 The long shaft can be further shortened by machining a double-sided chamfer onto it.

(If altering the standard chamfer and shortening the shaft are not required, indicate "*" for both the L1 and X dimensions.)
 ● Since L1 is a standard chamfer, dimension E1 is 0.5 mm or more, and 1 mm or more with a shaft bore size of $\phi 30$.
 ● Applicable shaft type: W

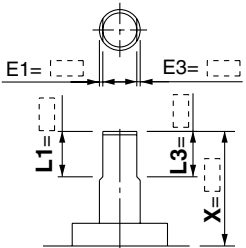

Size	X	L1	L3 max
10	5 to 14	9-(14-X) to (X-3)	X-3
15	8 to 18	10-(18-X) to (X-4)	X-4
20	10 to 20	10-(20-X) to (X-4.5)	X-4.5
30	10 to 22	12-(22-X) to (X-5)	X-5

Symbol: A14 Applicable to single vane type only

A special end is machined onto the long shaft, and a through-hole is drilled into it. Female threads are machined into the through-hole, whose diameter is equivalent to the pilot hole diameter.

- Not available for size 10.
- The maximum dimension L1 is, as a rule, twice the thread size. (Example) For M3: L1 max. = 6 mm
- A parallel key is used on the long shaft for size 40.
- Applicable shaft type: W

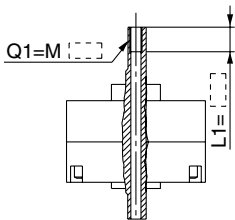

Thread	Size	15	20	30	40
M3 x 0.5		$\phi 2.5$	$\phi 2.5$	$\phi 2.5$	$\phi 2.5$
M4 x 0.7		—	$\phi 3.3$	$\phi 3.3$	—
M5 x 0.8		—	—	$\phi 4.2$	—

Symbol: A17 Shorten the long shaft.

- Applicable shaft type: W

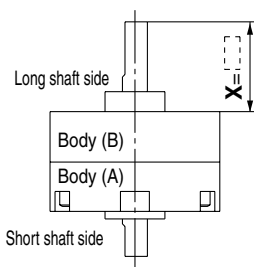

Size	X
10	3 to 14
15	4 to 18
20	4.5 to 20
30	5 to 22
40	18 to 33

Axial: Bottom (Short shaft side)

Symbol: A10 The short shaft can be further shortened by changing the length of the standard chamfer.

(If shortening the shaft is not required, indicate "*" for dimension Y.)
 ● Applicable shaft type: W

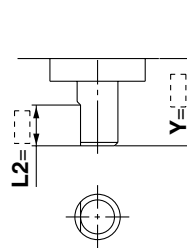

Size	Y	L2
10	3 to 8	5-(8-Y) to (Y-1)
15	3 to 9	6-(9-Y) to (Y-1.5)
20	3 to 10	7-(10-Y) to (Y-1.5)
30	5 to 13	8-(13-Y) to (Y-2)
40	7 to 15	9-(15-Y) to (Y-2)

Symbol: A12 The short shaft can be further shortened by machining a double-sided chamfer onto it.

(If altering the standard chamfer and shortening the shaft are not required, indicate "*" for both the L2 and Y dimensions.)
 ● Since L2 is a standard chamfer, dimension E2 is 0.5 mm or more, and 1 mm or more with shaft bore sizes of $\phi 30$ or $\phi 40$.
 ● Applicable shaft type: W

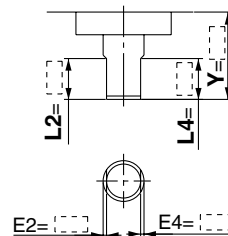

Size	Y	L2	L4 max
10	3 to 8	5-(8-Y) to (Y-1)	Y-1
15	3 to 9	6-(9-Y) to (Y-1.5)	Y-1.5
20	3 to 10	7-(10-Y) to (Y-1.5)	Y-1.5
30	5 to 13	8-(13-Y) to (Y-2)	Y-2
40	7 to 15	9-(15-Y) to (Y-2)	Y-2

Symbol: A15 Applicable to single vane type only

A special end is machined onto the short shaft, and a through-hole is drilled into it. Female threads are machined into the through-hole, whose diameter is equivalent to the pilot hole diameter.

- A parallel key is used on the long shaft for size 40.
- Not available for size 10.
- The maximum dimension L2 is, as a rule, twice the thread size. (Example) For M4: L2 max. = 8 mm
- Applicable shaft type: W

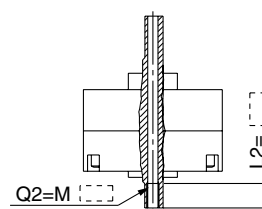

Thread	Size	15	20	30	40
M3 x 0.5		$\phi 2.5$	$\phi 2.5$	$\phi 2.5$	$\phi 2.5$
M4 x 0.7		—	$\phi 3.3$	$\phi 3.3$	—
M5 x 0.8		—	—	$\phi 4.2$	—

Symbol: A18 Shorten the short shaft.

- A parallel key is used on the long shaft for size 40.
- Applicable shaft type: W

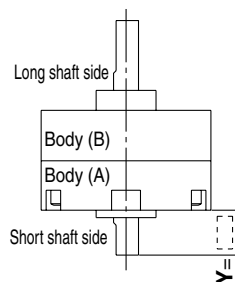

Size	Y
10	1 to 8
15	1.5 to 9
20	1.5 to 10
30	2 to 13
40	4.5 to 15

Axial: Top (Long shaft side)

Symbol: A21 The long shaft can be further shortened by machining it into a stepped round shaft with a double-sided chamfer.

(If shortening the shaft is not required, indicate "*" for dimension X.)

- Applicable shaft type: W
- Equal dimensions are indicated by the same marker.
- (If not specifying dimension C1, indicate "*" instead.)

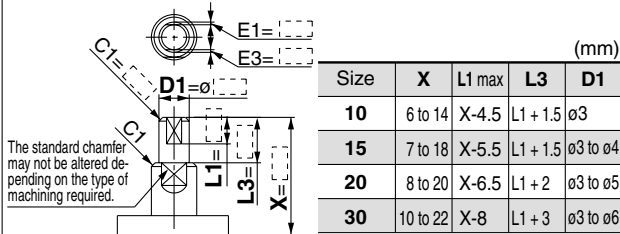

Axial: Bottom (Short shaft side)

Symbol: A22 The short shaft can be further shortened by machining it into a stepped round shaft with a double-sided chamfer.

(If shortening the shaft is not required, indicate "*" for dimension Y.)

- Applicable shaft type: W
- Equal dimensions are indicated by the same marker.
- (If not specifying dimension C2, indicate "*" instead.)

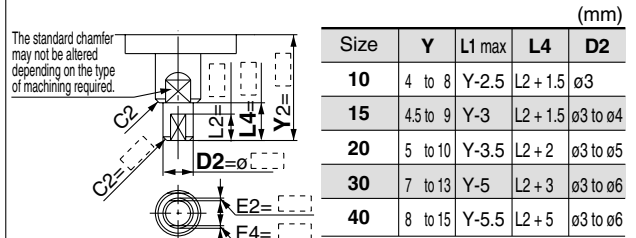

Double Shaft

Symbol: A13 Applicable to single vane type only

- Shaft with through-hole
- Not available for size 10.
 - Minimum machining diameter for d1 is 0.1 mm.
 - A parallel key is used on the long shaft for size 40.
 - Applicable shaft type: W

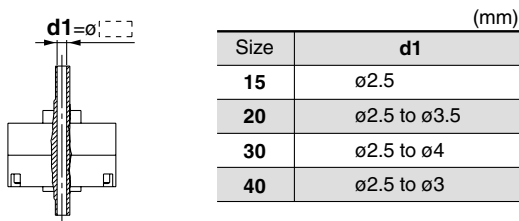

Symbol: A16 Applicable to single vane type only

A special end is machined onto both the long and short shafts, and a through-hole is drilled into both shafts. Female threads are machined into the through-holes, whose diameter is equivalent to the diameter of the pilot holes.

- Not available for size 10.
- The maximum dimension L1 is, as a rule, twice the thread size.
(Example) For M5: L1 max. = 10 mm
- A parallel key is used on the long shaft for size 40.
- Applicable shaft type: W
- Equal dimensions are indicated by the same marker.

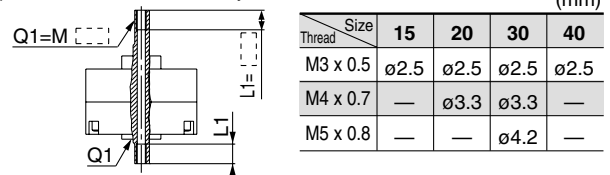

Symbol: A19 Both the long shaft and short shaft are shortened.

- A parallel key is used on the long shaft for size 40.
- Applicable shaft type: W

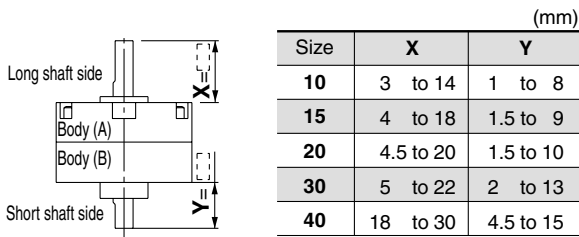

Symbol: A20 The rotation axis is reversed.

- (The long shaft and short shaft are shortened.)
- A parallel key is used on the long shaft for size 40.
 - Applicable shaft type: W

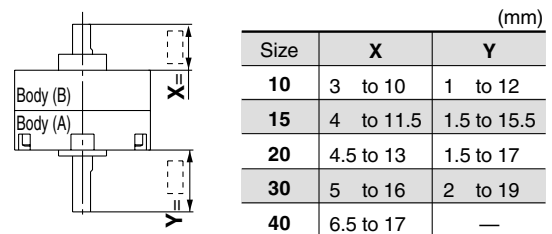

Symbol: A23 The long shaft can be further shortened by machining right-angle double-sided chamfer onto it.

(If altering the standard chamfer and shortening the shaft are not required, indicate "*" for both the L1 and X dimensions.)

- Since L1 is a standard chamfer, dimension E1 is 0.5 mm or more, and 1 mm or more with a shaft bore sizes of ø30 or ø40.
- Applicable shaft type: W

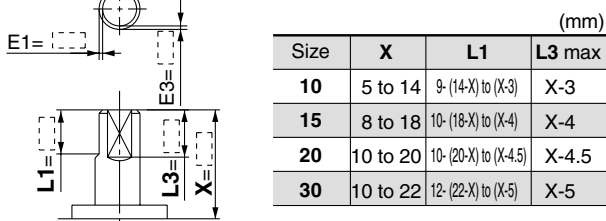

Symbol: A24 Double key

Keys and keyways are machined at 180° from the standard position.

- Applicable shaft type: W
- Equal dimensions are indicated by the same marker.

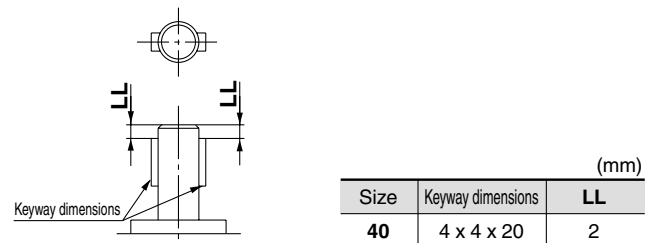

CRB2

CRBU2

CRB1

MSU

CRJ

CRA1

CRQ2

MSQ

MSZ

CRQ2X

MSQX

MRQ

D-□

Series CRB2 (Size: 10, 15, 20, 30, 40)

Simple Specials:

-XA31 to -XA58: Shaft Pattern Sequencing II

Shaft shape pattern is dealt with simple made-to-order system. (Refer to front matter 33). Please contact SMC for a specification sheet when placing an order.

Shaft Pattern Sequencing II

-XA31 to XA58

Applicable shaft type: J, K, S, T, Y

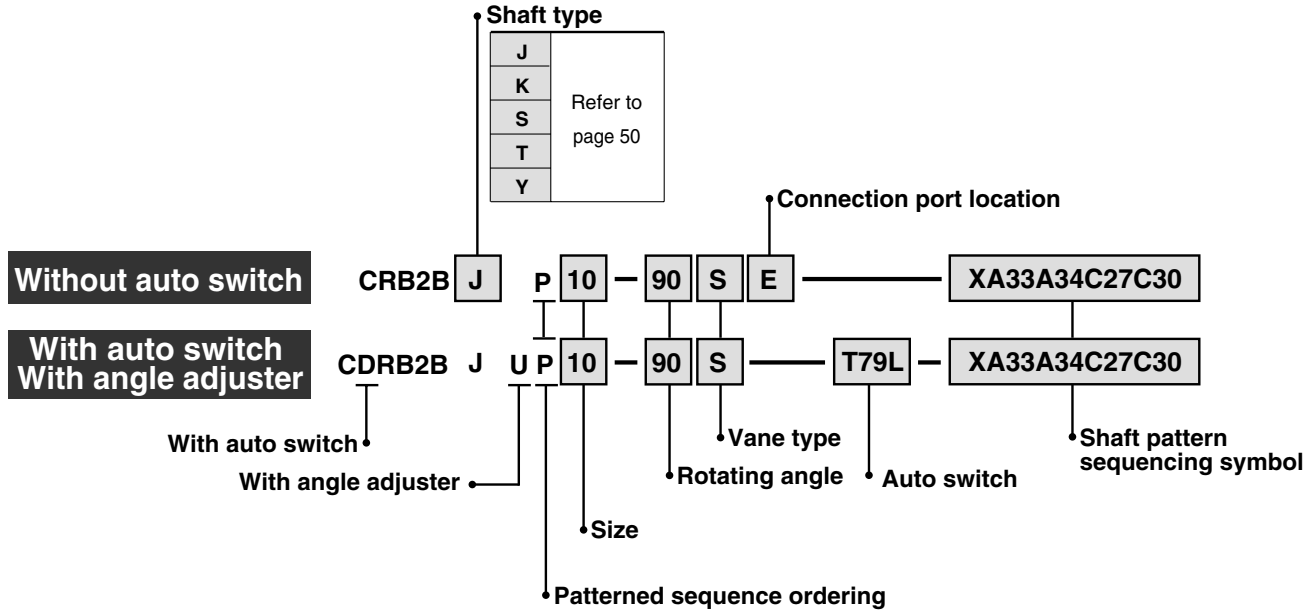

Shaft Pattern Sequencing Symbol

● Axial: Top (Long shaft side)

Symbol	Description	Shaft type	Applicable size				
			10	15	20	30	40
XA31	Shaft-end female thread	S, Y	●	●	●		
XA33	Shaft-end female thread	J, K, T		●	●	●	●
XA37	Stepped round shaft	J, K, T	●	●	●	●	●
XA45	Middle-cut chamfer	J, K, T	●	●	●	●	●
XA47	Machined keyway	J, K, T			●	●	
XA48	Change of long shaft length	S, Y	●	●	●	●	●
XA51	Change of long shaft length	J, K, T	●	●	●	●	●

● Axial: Bottom (Short shaft side)

Symbol	Description	Shaft type	Applicable size				
			10	15	20	30	40
XA32	Shaft-end female thread	S, Y		●	●	●	
XA34	Shaft-end female thread	J, K, T		●	●	●	●
XA38	Stepped round shaft	K	●	●	●	●	●
XA46	Middle-cut chamfer	K	●	●	●	●	●
XA49	Change of short shaft length	Y	●	●	●	●	●
XA52	Change of short shaft length	K	●	●	●	●	●
XA55	Change of short shaft length	J	●	●	●	●	●

● Double Shaft

Symbol	Description	Shaft type	Applicable size				
			10	15	20	30	40
XA39*	Shaft through-hole	S, Y		●	●	●	●
XA40*	Shaft through-hole	K, T		●	●	●	●
XA41*	Shaft through-hole	J		●	●	●	●
XA42*	Shaft through-hole + Shaft-end female thread	S, Y		●	●	●	●
XA43*	Shaft through-hole + Shaft-end female thread	K, T		●	●	●	●
XA44*	Shaft through-hole + Shaft-end female thread	J		●	●	●	●
XA50*	Change of double shaft length	Y	●	●	●	●	●
XA53*	Change of double shaft length	K	●	●	●	●	●
XA57*	Change of double shaft length	J	●	●	●	●	●
XA58*	Reversed shaft, Change of double shaft length	J	●	●	●	●	●



* These specifications are not available for rotary actuators with auto switch unit and angle adjuster.

Combination

XA□ Combination

Symbol	Description	Axial direction		Applicable shaft type					Combination																												
		Up	Down	J	K	S	T	Y																													
XA31	Shaft-end female thread	●				●		●	XA31	* Corresponding shafts type available for combination.																											
XA32	Shaft-end female thread		●			●		●	XA32																												
XA33	Shaft-end female thread	●		●	●		●		XA33																												
XA34	Shaft-end female thread		●	●	●		●		●	XA34																											
XA37	Stepped round shaft	●		●	●		●		●	XA37																											
XA38	Stepped round shaft		●		●				K*	K*	XA38																										
XA39	Shaft through-hole	●	●			●		●				XA39																									
XA40	Shaft through-hole	●	●			●		●				XA40																									
XA41	Shaft through-hole	●	●	●								XA41																									
XA42	Shaft through-hole + Shaft-end female thread	●	●			●		●				XA42																									
XA43	Shaft through-hole + Shaft-end female thread	●	●			●		●				XA43																									
XA44	Shaft through-hole + Shaft-end female thread	●	●	●								XA44																									
XA45	Middle-cut chamfer	●		●	●		●					XA45																									
XA46	Middle-cut chamfer		●		●							XA46																									
XA47	Machined keyway	●		●	●		●					XA47																									
XA48	Change of long shaft length	●				●		●				●	XA48																								
XA49	Change of short shaft length		●					●	Y*			Y*	Y*	XA49																							
XA50	Change of double shaft length	●	●					●				Y*	Y*	●	XA50																						
XA51	Change of long shaft length	●		●	●		●				●	K, T*	J*	K, T*	J*	●	K*	●			XA51																
XA52	Change of short shaft length		●		●						K*		K*	K*		K*	K*	K*			K*	XA52															
XA53	Change of double shaft length	●	●		●							K*		K*	K*	K*					K*	●	XA53														
XA55	Change of short shaft length	●	●								J*		J*	J*		J*					J*		XA55														
XA57	Change of double shaft length	●	●							J*		J*	J*	J*	J*						J*		●	XA57													
XA58	Reversed shaft, Change of double shaft length	●	●								J*		J*	J*	J*	J*					J*		J*	J*													

A combination of up to two XA□s are available.
Example: XA31A32

XA□, XC□ Combination

Combination other than XA□, such as Made to Order (XC□), is also available.
Refer to pages 79 to 80 for details of made-to-order specifications.

Symbol	Description	Applicable size	Combination
			XA31 to XA58
XC 1*	Add connection port location	10, 15, 20, 30, 40	●
XC 2*	Change threaded hole to through-hole	15, 20, 30, 40	●
XC 3*	Change the screw position	10, 15, 20, 30, 40	●
XC 4	Change rotation range		●
XC 5*	Change rotation range between 0 to 200°		●
XC 6*	Change rotation range between 0 to 110°		●
XC 7*	Reversed shaft		—
XC30	Fluorine grease		●

* These specifications are not available for rotary actuators with auto switch unit and angle adjuster.
A total of four XA□ and XC□ combinations is available.
Example: XA33A34C5C30

CRB2

CRBU2

CRB1

MSU

CRJ

CRA1

CRQ2

MSQ

MSZ

CRQ2X
MSQX

MRQ

D-□

Axial: Top (Long shaft side)

Symbol: A31 Machine female threads into the long shaft.

- The maximum dimension L1 is, as a rule, twice the thread size. (Example) For M3: L1 = 6 mm
- Applicable shaft types: S, Y

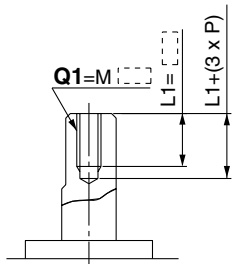

Size	Q1 (mm)	
	S	Y
10	Not available	
15	M3	
20	M3, M4	
30	M3, M4, M5	

Symbol: A33 Machine female threads into the long shaft.

- The maximum dimension L1 is, as a rule, twice the thread size. (Example) For M3: L1 = 6 mm
- Applicable shaft types: J, K, T

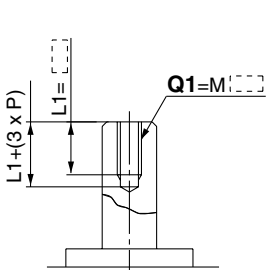

Size	Q1 (mm)		
	J	K	T
10	Not available		
15	M3		
20	M3, M4		
30	M3, M4, M5		
40	M3, M4, M5		

Symbol: A37 The long shaft can be further shortened by machining it into a stepped round shaft.

- (If shortening the shaft is not required, indicate "*" for dimension X.)
- Applicable shaft types: J, K, T
 - Equal dimensions are indicated by the same marker. (If not specifying dimension C1, indicate "*" instead.)

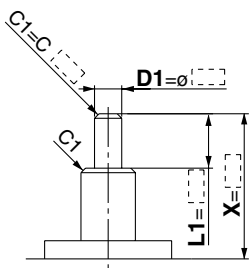

Size	X (mm)			
	X	L1 max	D1	
10	4 to 14	X-3	ø3 to ø3.9	
15	5 to 18	X-4	ø3 to ø4.9	
20	6 to 20	X-4.5	ø3 to ø5.9	
30	6 to 22	X-5	ø3 to ø7.9	
40	8 to 30	X-6.5	ø3 to ø9.9	

Symbol: A45 The long shaft can be further shortened by machining a middle-cut chamfer into it. (The position of the chamfer is same as the standard one.)

- (If shortening the shaft is not required, indicate "*" for dimension X.)
- Applicable shaft types: J, K, T

Size	X (mm)											
	X			W1			L1 max			L3 max		
	J	K	T	J	K	T	J	K	T	J	K	T
10	6.5 to 14			0.5 to 2			X-3			L1-1		
15	8 to 18			0.5 to 2.5			X-4			L1-1		
20	9 to 20			0.5 to 3			X-4.5			L1-1		
30	11.5 to 22			0.5 to 4			X-5			L1-2		
40	15.5 to 30			0.5 to 5			X-5.5			L1-2		

Axial: Bottom (Short shaft side)

Symbol: A32 Machine female threads into the short shaft.

- The maximum dimension L2 is, as a rule, twice the thread size. (Example) For M4: L2 = 8 mm
- However, for M5 with S shaft, the maximum dimension L2 is 1.5 times the thread size.
- Applicable shaft types: S, Y

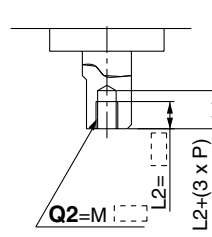

Size	Q2 (mm)	
	S	Y
10	Not available	
15	M3	
20	M3, M4	
30	M3, M4, M5	

Symbol: A34 Machine female threads into the short shaft.

- The maximum dimension L2 is, as a rule, twice the thread size. (Example) For M3: L2 = 6 mm
- However, for M5 with T shaft, the maximum dimension L2 is 1.5 times the thread size.
- Applicable shaft types: J, K, T

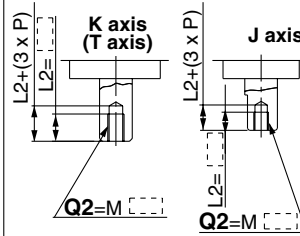

Size	Q2 (mm)		
	J	K	T
10	Not available		
15	M3		
20	M3, M4		
30	M3, M4, M5		
40	M3, M4, M5		

Symbol: A38 The short shaft can be further shortened by machining it into a stepped round shaft.

- (If shortening the shaft is not required, indicate "*" for dimension Y.)
- Applicable shaft type: K
 - Equal dimensions are indicated by the same marker. (If not specifying dimension C2, indicate "*" instead.)

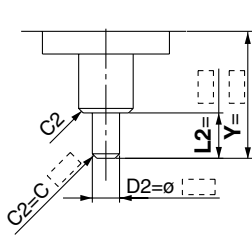

Size	Y (mm)			
	Y	L2 max	Q2	
10	2 to 14	Y-1	ø3 to ø3.9	
15	3 to 18	Y-1.5	ø3 to ø4.9	
20	3 to 20	Y-1.5	ø3 to ø5.9	
30	3 to 22	Y-2	ø3 to ø7.9	
40	6 to 30	Y-4.5	ø5 to ø9.9	

Symbol: A46 The short shaft can be further shortened by machining a middle-cut chamfer into it. (The position of the chamfer is same as the standard one.)

- (If shortening the shaft is not required, indicate "*" for dimension Y.)
- Applicable shaft type: K

Size	Y (mm)				
	Y	W2	L2 max	L4 max	
	10	4.5 to 14	0.5 to 2	Y-1	L2-1
15	5.5 to 18	0.5 to 2.5	Y-1.5	L2-1	
20	6 to 20	0.5 to 3	Y-1.5	L2-1	
30	8.5 to 22	0.5 to 4	Y-2	L2-2	
40	13.5 to 30	0.5 to 5	Y-4.5	L2-2	

Axial: Top (Long shaft side)

Symbol: A47 Machine a keyway into the long shaft. (The position of the keyway is the same as the standard one.) The key must be ordered separately.

- Applicable shaft types: J, K, T

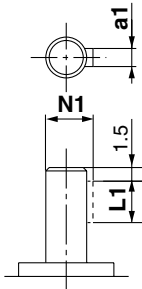

Size	a1	L1	N1
20	2h9 ₀ ⁰ / _{-0.025}	10	6.8
30	3h9 ₀ ⁰ / _{-0.025}	14	9.2

Symbol: A48 Shorten the long shaft.

- Applicable shaft types: S, Y

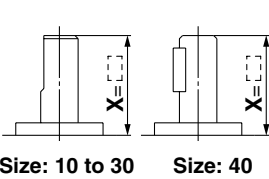

Size	X
10	3 to 14
15	4 to 18
20	4.5 to 20
30	5 to 22
40	18 to 30

Symbol: A51 Shorten the long shaft.

- Applicable shaft types: J, K, T

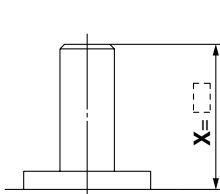

Size	X
10	3 to 14
15	4 to 18
20	4.5 to 20
30	5 to 22
40	6.5 to 30

Axial: Bottom (Short shaft side)

Symbol: A49 Shorten the short shaft.

- Applicable shaft type: Y

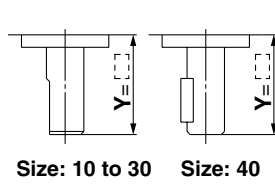

Size	Y
10	1 to 14
15	1.5 to 18
20	1.5 to 20
30	2 to 22
40	18 to 30

Symbol: A52 Shorten the short shaft.

- Applicable shaft type: K

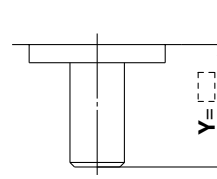

Size	Y
10	1 to 14
15	1.5 to 18
20	1.5 to 20
30	2 to 22
40	4.5 to 30

Symbol: A55 Shorten the short shaft.

- Applicable shaft type: J

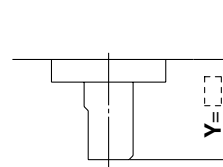

Size	Y
10	1 to 8
15	1.5 to 9
20	1.5 to 10
30	2 to 13
40	4.5 to 15

Double Shaft

Symbol: A39 Applicable to single vane type only

- Shaft with through-hole (Additional machining of S, Y shaft)
- Applicable shaft types: S, Y
- Equal dimensions are indicated by the same marker.
- Not available for size 10.
- A parallel key is used on the long shaft for size 40.
- Minimum machining diameter for d1 is 0.1 mm.

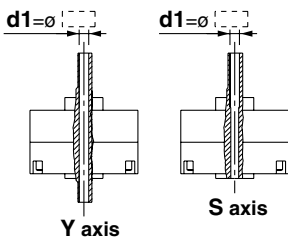

Size	Shaft type	
	S	Y
15	d1	
20	d1	
30	d1	
40	d1	

Symbol: A40 Applicable to single vane type only

- Shaft with through-hole (Additional machining of K, T shaft)
- Applicable shaft types: K, T
- Equal dimensions are indicated by the same marker.
- Not available for size 10.
- d1 = ø2.5, L1 = 18 (max.) for size 15 ; minimum machining diameter for d1 is 0.1 mm.
- d1 = d3 for sizes 20 to 40.

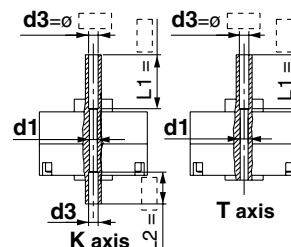

Size	Shaft type	
	K	T
15	d1	d3
20	—	d3
30	—	d3
40	—	d3

Series CRB2

Symbol: A41

Applicable to single vane type only

Shaft with through-hole

- Not available for size 10.
- Applicable shaft type: J
- Equal dimensions are indicated by the same marker.

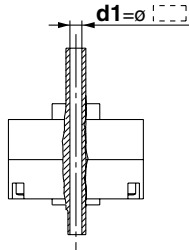

Size	d1 (mm)
15	ø2.5
20	ø2.5 to ø3.5
30	ø2.5 to ø4
40	ø2.5 to ø4.5

Symbol: A42

Applicable to single vane type only

A special end is machined onto both the long and short shafts, and a through-hole is drilled into both shafts. Female threads are machined into the through-holes, whose diameter is equivalent to the diameter of the pilot holes.

- Not available for size 10.
- The maximum dimension L1 is, as a rule, twice the thread size.
- However, for M5 on the short shaft of S shaft : L1 max. = 7.5 mm
- A parallel key is used on the long shaft for size 40.
- Applicable shaft types: S, Y
- Equal dimensions are indicated by the same marker.

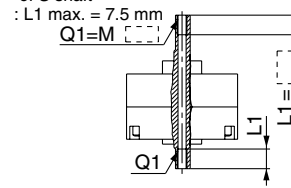

Thread	Size 15		Size 20		Size 30		Size 40	
	S	Y	S	Y	S	Y	S	Y
M3 x 0.5	ø2.5	ø2.5	ø2.5	ø2.5	ø2.5	ø2.5	ø2.5	ø2.5
M4 x 0.7	—	—	ø3.3	ø3.3	ø3.3	ø3.3	—	—
M5 x 0.8	—	—	—	—	ø4.2	ø4.2	—	—

Symbol: A43

Applicable to single vane type only

A special end is machined onto both the long and short shafts, and a through-hole is drilled into both shafts. Female threads are machined into the through-holes, whose diameter is equivalent to the diameter of the pilot holes.

- Not available for size 10.
- The maximum dimension L1 is, as a rule, twice the thread size.
- (Example) For M5: L1 max. = 10 mm
- However, for M5 on the short shaft of T shaft : L1 max. = 7.5 mm
- Applicable shaft types: K, T
- Equal dimensions are indicated by the same marker.

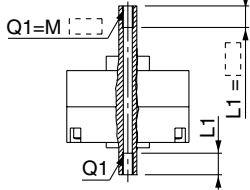

Thread	Size 15		Size 20		Size 30		Size 40	
	K	T	K	T	K	T	K	T
M3 x 0.5	ø2.5	ø2.5	ø2.5	ø2.5	ø2.5	ø2.5	ø2.5	ø2.5
M4 x 0.7	—	—	ø3.3	ø3.3	ø3.3	ø3.3	ø3.3	ø3.3
M5 x 0.8	—	—	—	—	ø4.2	ø4.2	ø4.2	ø4.2

Symbol: A44

Applicable to single vane type only

A special end is machined onto both the long and short shafts, and a through-hole is drilled into both shafts. Female threads are machined into the through-holes, whose diameter is equivalent to the diameter of the pilot holes.

- Not available for size 10.
- The maximum dimension L1 is, as a rule, twice the thread size.
- (Example) For M5: L1 max. = 10 mm
- A parallel key is used on the long shaft for size 40.
- Applicable shaft type: J
- Equal dimensions are indicated by the same marker.

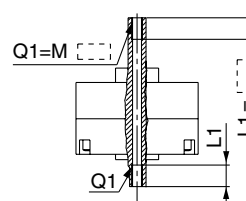

Thread	Size 15		Size 20		Size 30		Size 40	
	S	Y	S	Y	S	Y	S	Y
M3 x 0.5	ø2.5	ø2.5	ø2.5	ø2.5	ø2.5	ø2.5	ø2.5	ø2.5
M4 x 0.7	—	—	ø3.3	ø3.3	ø3.3	ø3.3	ø3.3	ø3.3
M5 x 0.8	—	—	—	—	ø4.2	ø4.2	ø4.2	ø4.2

Symbol: A50

Shorten both long and short shafts.

- Applicable shaft type: Y

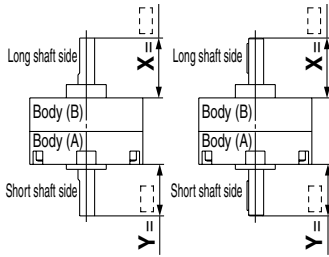

Size: 10 to 30

Size: 40

Size	X (mm)	Y (mm)
10	3 to 14	1 to 14
15	4 to 18	1.5 to 18
20	4.5 to 20	1.5 to 20
30	5 to 22	2 to 22
40	18 to 30	18 to 30

Symbol: A53

Shorten both long and short shafts.

- Applicable shaft type: K

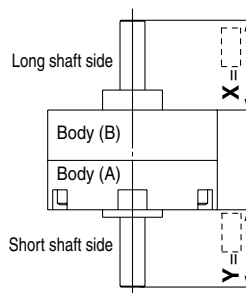

Size	X (mm)	Y (mm)
10	3 to 14	1 to 14
15	4 to 18	1.5 to 18
20	4.5 to 20	1.5 to 20
30	5 to 22	2 to 22
40	6.5 to 30	4.5 to 30

Symbol: A57

Shorten both long and short shafts.

- Applicable shaft type: J

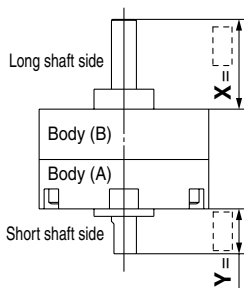

Size	X (mm)	Y (mm)
10	3 to 14	1 to 14
15	4 to 18	1.5 to 18
20	4.5 to 20	1.5 to 20
30	5 to 22	2 to 22
40	6.5 to 30	4.5 to 30

Symbol: A58

The rotation axis is reversed. The long shaft and short shaft are shortened.

(If shortening the shaft is not required, indicate "*" for dimension X, Y.)

- Applicable shaft type: J

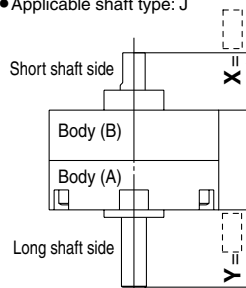

Size	X (mm)	Y (mm)
10	3 to 10	1 to 12
15	4 to 11.5	1.5 to 15.5
20	4.5 to 13	1.5 to 17
30	5 to 16	2 to 19
40	6.5 to 17	4.5 to 28

Series **CRB2** (Size: 10, 15, 20, 30, 40)

Made to Order Specifications: XC1, 2, 3, 4, 5, 6, 7, 30

XC1 to XC7, XC30

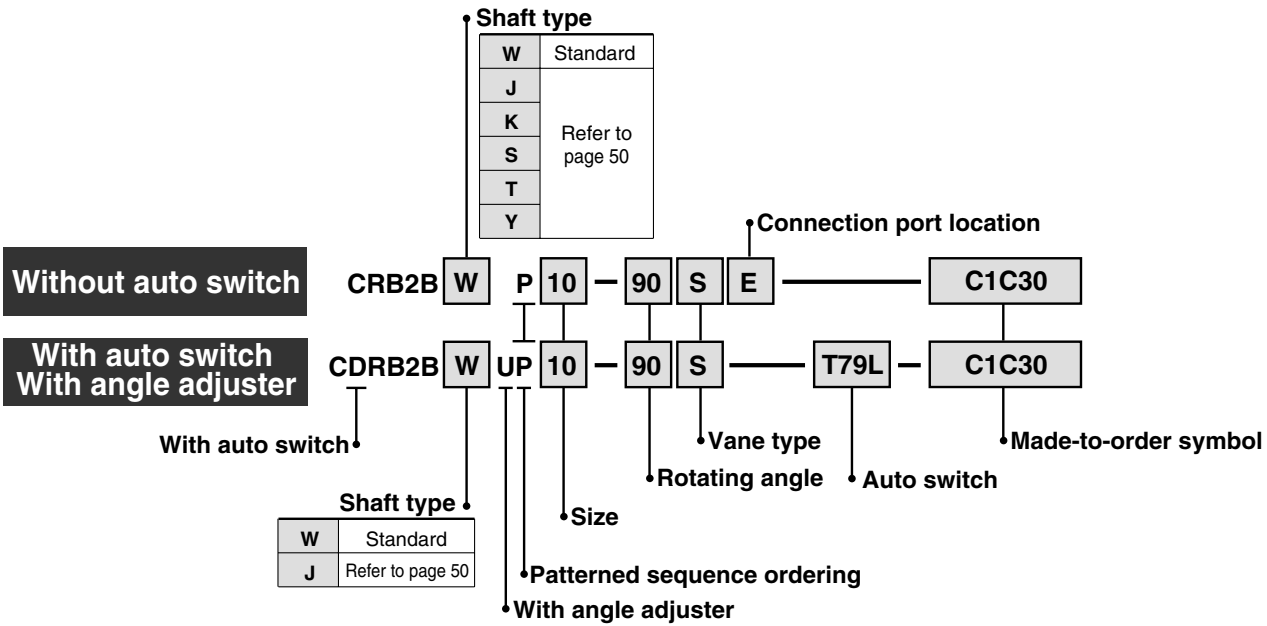

- CRB2
- CRBU2
- CRB1
- MSU
- CRJ
- CRA1
- CRQ2
- MSQ
- MSZ
- CRQ2X
- MSQX
- MRQ

Made to Order Symbol

Symbol	Description	Applicable shaft type	Applicable size
		W, J, K, S, T, Y	
XC 1*	Add connection port	●	10 15 20 30 40
XC 2*	Change threaded holes to through-hole	●	
XC 3*	Change the screw position	●	
XC 4	Change rotation range	●	
XC 5*	Change rotation range between 0 to 200°	●	
XC 6*	Change rotation range between 0 to 110°	●	
XC 7*	Reversed shaft	W, J	
XC30	Fluorine grease	●	

* For products with auto switch; angle adjustment unit cannot be selected.

Combination

Symbol	Combination						
XC 1	XC1						
XC 2	●	XC2					
XC 3	●	—	XC3				
XC 4	●	●	●	XC4			
XC 5	●	●	●	—	XC5		
XC 6	●	●	●	—	—	XC6	
XC 7	●	●	●	●	●	—	XC7
XC30	●	●	●	●	●	●	●

Symbol: C1 Add connecting ports on Body (A).
(An additionally machined port will have an aluminum surface since it will be left unfinished.)

- Parallel key is used on the long shaft for size 40.
- This specification is not available for the rotary actuator with auto switch unit.

Size	Q	M	N
10	M3	8.5	9.5
15	M3	11	10
20	M5	14	13
30	M5	15.5	14
40	M5	21	20

Symbol: C2 Change 3 threaded holes on Body (B) into through holes.
(An additionally machined port will have an aluminum surface since it will be left unfinished.)

- This specification is not available for the rotary actuator with auto switch unit.

Size	d
15	3.4
20	4.5
30	5.5
40	5.5

(Top view from long shaft side)

D-□

Series CRB2

Symbol: C3

Change the position of the screws for tightening the actuator body.

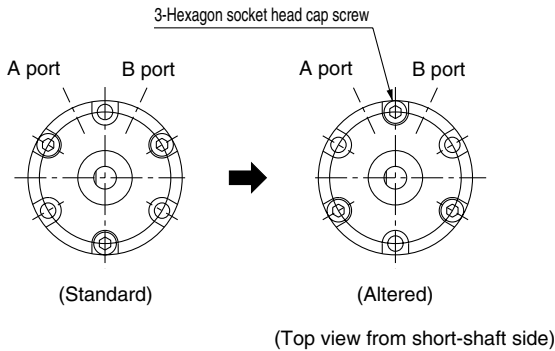

Symbol: C5

Applicable to single vane type only

Start of rotation is 45° up from the bottom of the vertical line to the left side

- Rotation tolerance for CRB2BW10 is $^{+5^\circ}_0$.
- Port size for CRB2BW10, 15 is M3.
- A parallel key is used instead of chamfer for size 40.

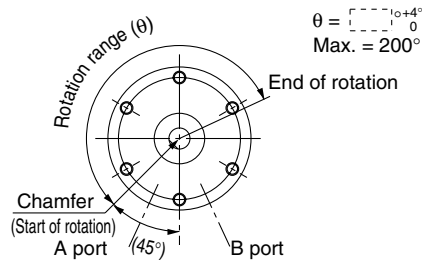

Start of rotation is the position of the chamfer (key) when B port is pressurized.
(Top view from long shaft side)

Symbol: C7

The shafts are reversed.

- Parallel key is used on the long shaft for size 40.

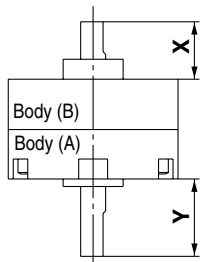

Size	Y	X
10	12	10
15	15.5	11.5
20	17	13
30	19	16
40	28	17

Symbol: C4

Applicable to single vane type only

Change rotation range to 90°.

Rotation starts from the horizontal line (90° down from the top to the right side)

- Rotation tolerance for CRB2BW10 is $^{+5^\circ}_0$.
- A parallel key is used instead of chamfer for size 40.

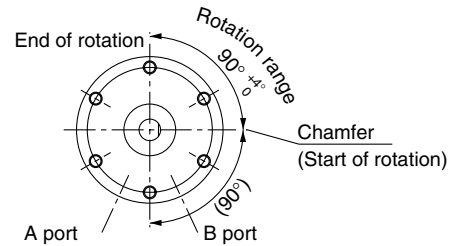

Start of rotation is the position of the chamfer (key) when A port is pressurized.
(Top view from long shaft side)

Symbol: C6

Applicable to single vane type only

Start of rotation is horizontal line (90° down from the top to the left side).

- Rotation tolerance for CRB2BW10 is $^{+5^\circ}_0$.
- A parallel key is used instead of chamfer for size 40.

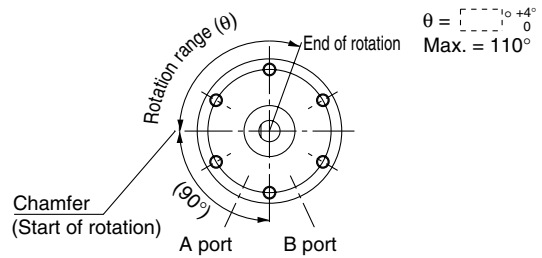

Start of rotation is the position of the chamfer (key) when B port is pressurized.
(Top view from long shaft side)

Symbol: C30

Change the standard grease to fluoro grease
(Not for low-speed specification.)