

Ejector Valve Unit

Series ZYY/ZYX

Nozzle diameter: $\varnothing 0.7$, $\varnothing 1.0$
Type S: Standard type
L: Large flow type

Ejectors and solenoid valves can be mounted on the same manifold.
Centralized wiring of ejector
(ZYX3000: Individual pressure switch not included)

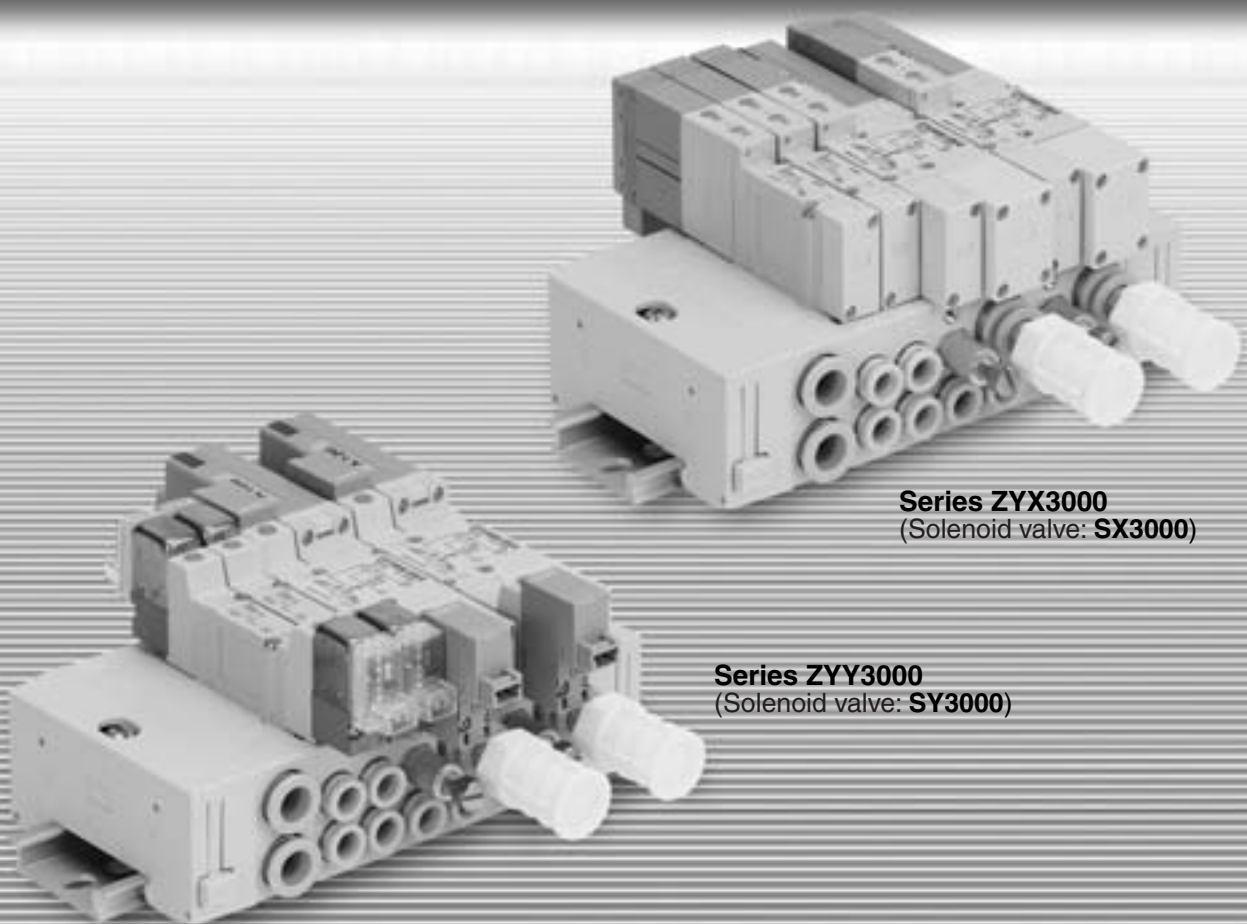

Series ZYX3000
(Solenoid valve: **SX3000**)

Series ZYY3000
(Solenoid valve: **SY3000**)

ZA

ZX

ZR

ZM

ZMA

ZQ

ZH

ZU

ZL

ZY□

ZF□

ZP□

SP

ZCUK

AMJ

AMV

AEP

HEP

Related
Equipment

Ejector Valve Unit

Series ZYY/ZYX

How to Order Ejector Valves for ZYY3000

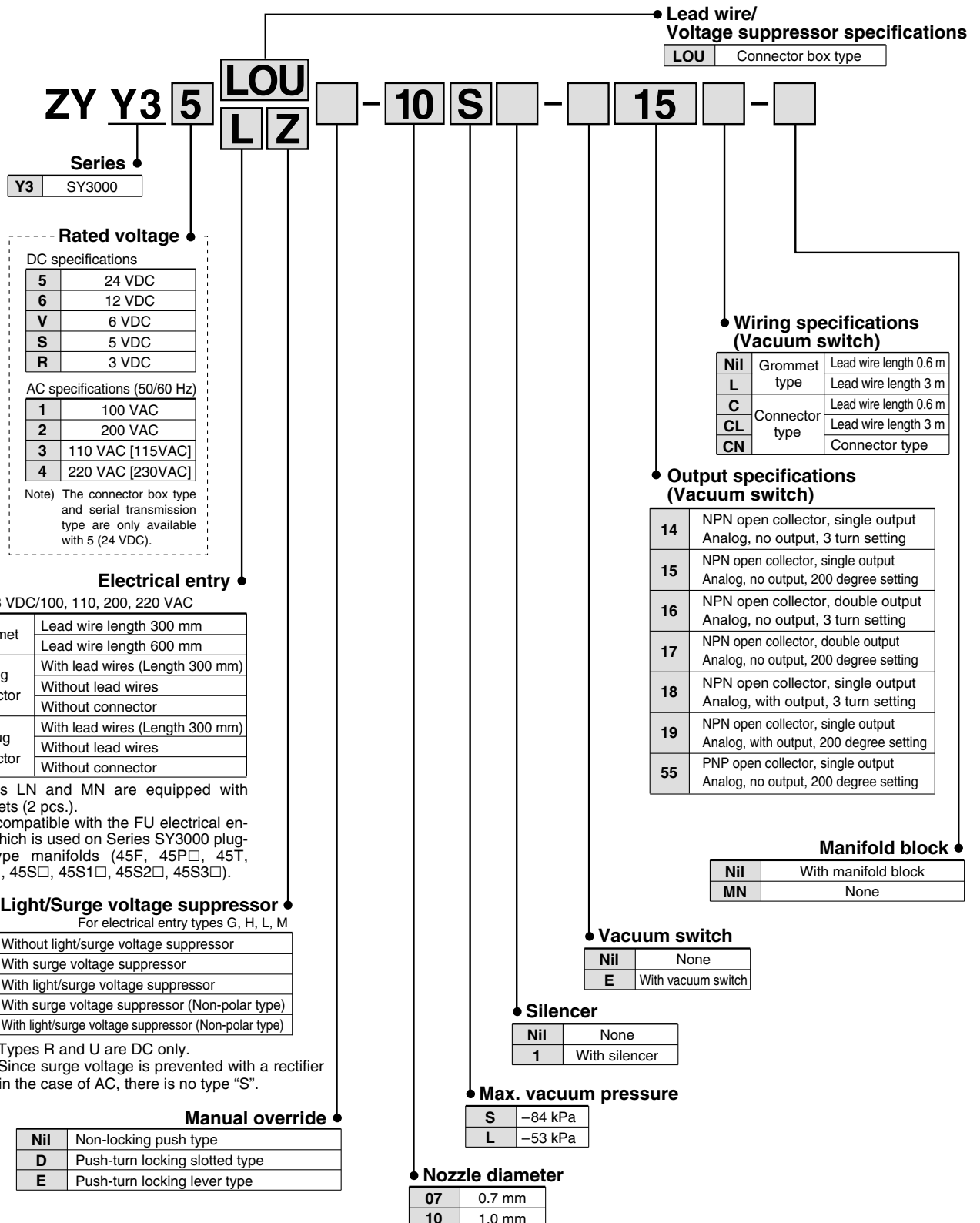

How to Order Ejector Valves for ZYX3000

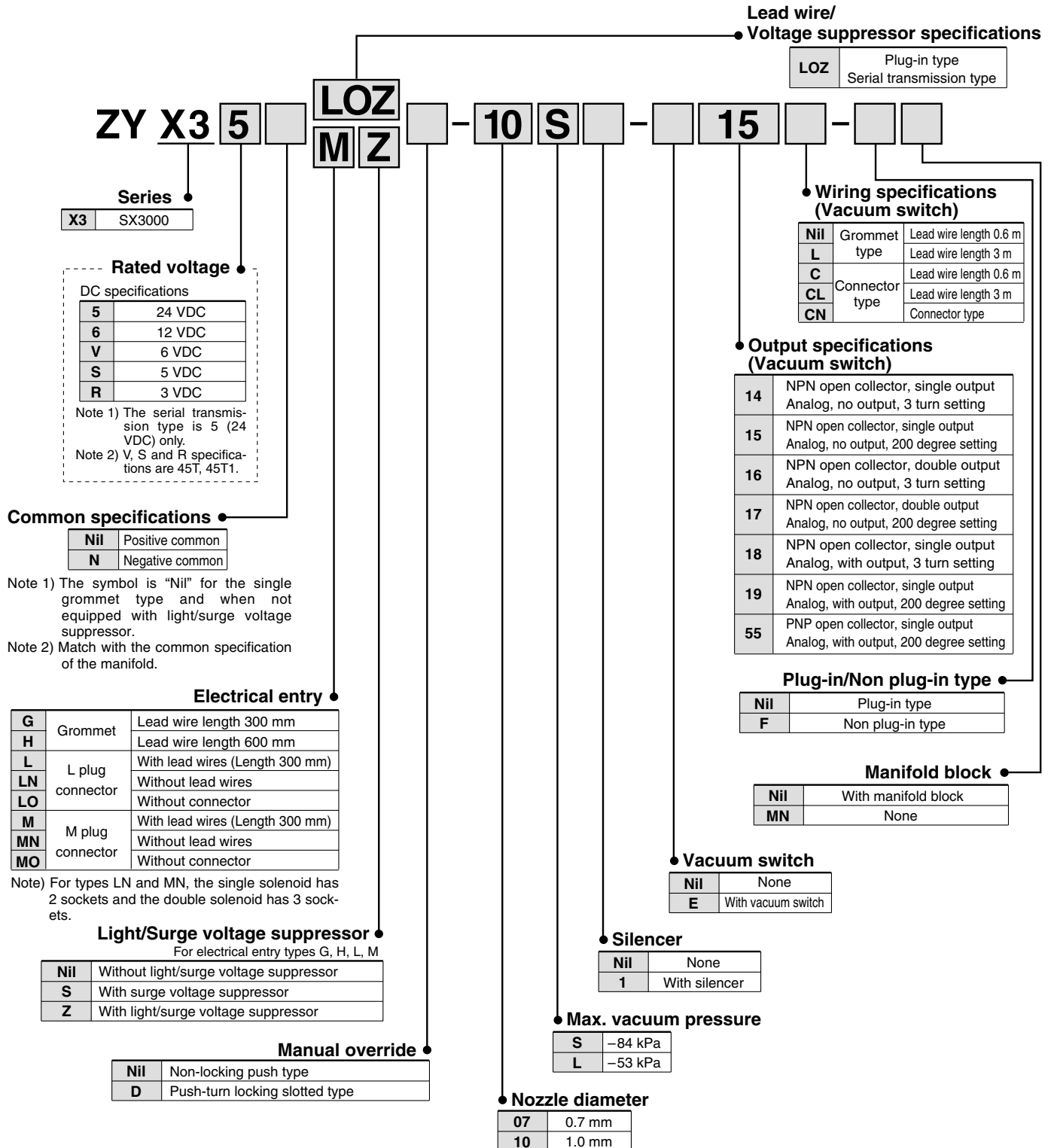

- ZA
- ZX
- ZR
- ZM
- ZMA
- ZQ
- ZH
- ZU
- ZL
- ZY□
- ZF□
- ZP□
- SP
- ZCUK
- AMJ
- AMV
- AEP
- HEP
- Related Equipment

Series ZYY/ZYX

How to Order Manifold Valves for ZYY3000/ZYX3000 (Split Base/DIN Rail Mounting)

For solenoid valve and ejector valve combination

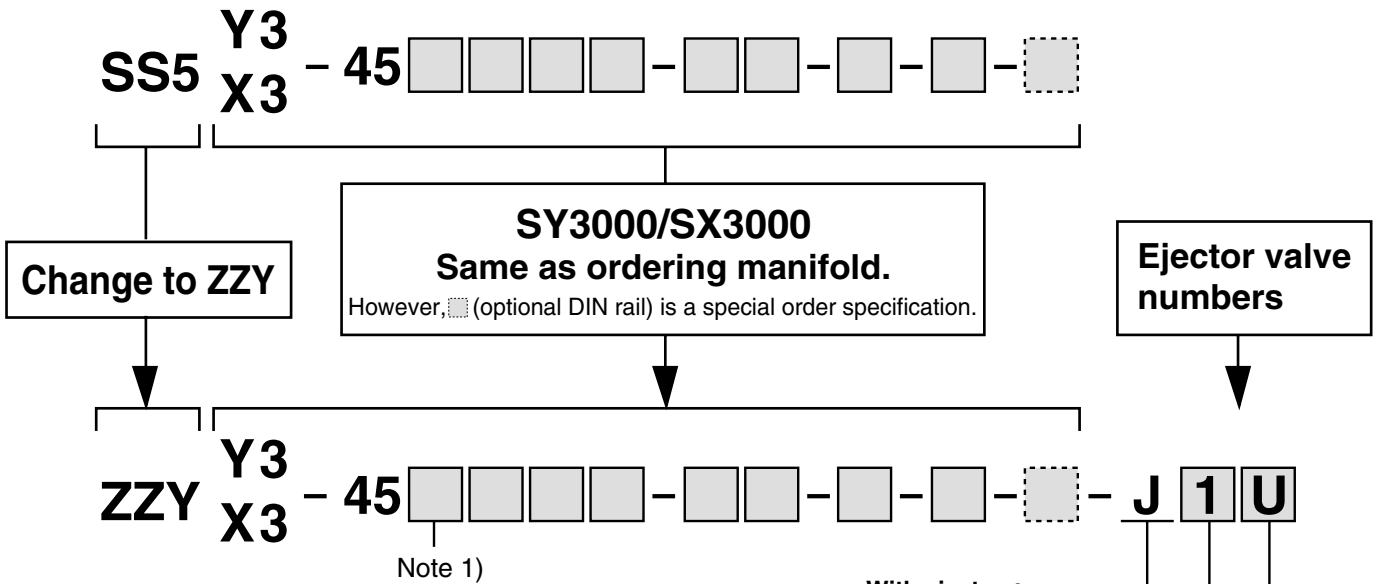

Enter the following together with the manifold number:

1. Part no. of solenoid for SY3000/SX3000
2. Part no. of ejector valve for ZYY3000/ZYX3000.

[Example: When individual wiring type model 45 for SY3000 is selected]

ZZY Y3-45-04D-C6- J1U ----- 1SET

SY3000 manifold model Ejector valve number

- * SX3000-75-1A ----- 1SET
- * SY3140-5LZ ----- 1SET
- * SY3240-5LZ ----- 1SET
- * ZYY35LZ-10S-E15C ----- 1SET

* is the symbol for a built-in assembly. Add the * symbol at the beginning of part numbers for solenoid valves, etc. to be mounted, and enter these together in order from the D side.

Note 1) The combined total of solenoid valve and ejector valve stations is a maximum of 20 stations.
(Example: When there are 12 solenoid valve stations, there are 8 ejector stations.)

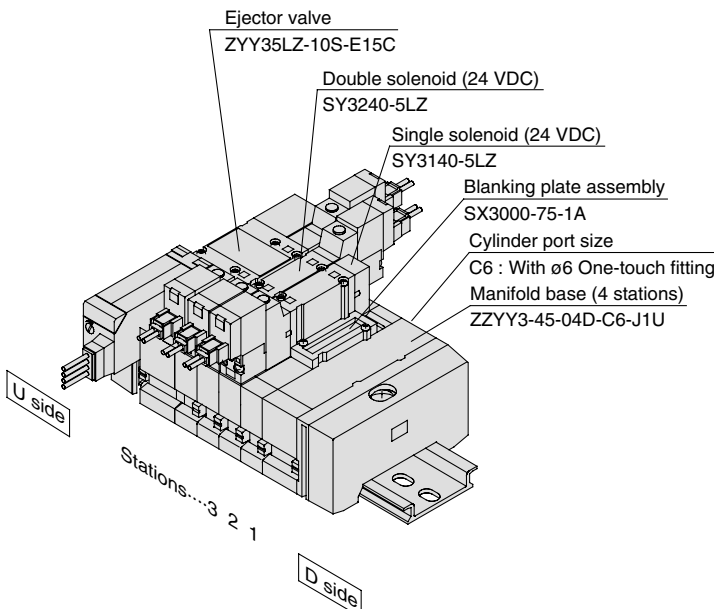

**For ejector valves only
(Without solenoid valves: individual wiring type is compliant only.)**

ZZY - J 1 U

With ejector ●
Number of ejectors ●
1 to 10

Example) ZYY-J3U ----- 1SET
* ZYY35MZ-10S1-E15C-F ----- 2SETS
* ZYY35MZ-10S1-F ----- 1SET

Series SY3000/SX3000 in manifold/split base combinations DIN rail mount type can be mounted

Compact (integrated construction of ejector and valve)
Copper-free and fluorine-free measures implemented

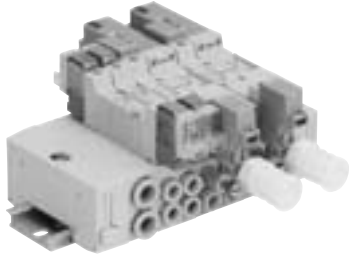

ZYY3000 Series

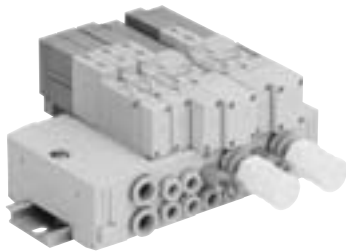

ZYX3000 Series

Ejector Valve Specifications

Ejector valve model	ZY□3□□□-07S	ZY□3□□□-07L	ZY□3□□□-10S	ZY□3□□□-10L
Nozzle diameter (mm)	0.7		1.0	
Max. suction flow rate N (l/min (ANR))	11	18	22	32
Max. vacuum pressure (kPa)	-84	-53	-84	-53
Maximum operating pressure	0.6 MPa			
Standard supply pressure	0.45 MPa			
Operating temperature range	5 to 50°C			

Supply/Release Valve Specifications

Valve type	Pilot type 3 position 3 port solenoid valve
Type of actuation	Closed center
Fluid	Air
Operating pressure range	0.2 to 0.6 MPa
Ambient and fluid temperature	5 to 50°C
Allowable voltage fluctuation	-10 to +10%
Electrical entry	Grommet : G, H L plug connector: L, LN, LO M plug connector: M, MN, MO
Power consumption	0.5 W (With indicator light: 0.6 W): Series ZYY3000 0.6 W (With indicator light: 0.65 W): Series ZYX3000
Effective area (Cv factor)	4.68 mm ² (0.26)

ZA

ZX

ZR

ZM

ZMA

ZQ

ZH

ZU

ZL

ZY□

ZF□

ZP□

SP

ZCUK

AMJ

AMV

AEP

HEP

Related Equipment

Series ZYY/ZYX

Electronic Vacuum Pressure Switch Specifications

Model	ZSE1-00-14□ -X129 (-X130)	ZSE1-00-15□ -X129 (-X130)	ZSE1-00-16□ -X129 (-X130)	ZSE1-00-17□ -X129 (-X130)	ZSE1-00-18□ -X129 (-X130)	ZSE1-00-19□ -X129 (-X130)	ZSE1-00-55□ -X129 (-X130)
Sensor type	Diffusion type semiconductor pressure sensor						
Set pressure range	0 to -101 kPa						
Hysteresis	1 to -10% of set pressure (Adjustable)		3% full span or less (Fixed)		1 to -10% of set pressure (Adjustable)		
Repeatability	±1% full span or less						
Temperature characteristics	±3% full span or less						
Operating voltage	12 to 24 VDC (Ripple ±10% or less)						
ON-OFF output	NPN open collector 30 V Max. 80 mA						PNP open collector Max. 80 mA
Analog output	None				1 to 5V		None
Setting points	1 point		2 point		1 point		
Operation indicator light	Lights up when ON (Red)		Lights up when ON (OUT1: Red, OUT2: Green)		Lights up when ON (Red)		
Setting trimmer rotation angle	3 turns	200 degrees	3 turns	200 degrees	3 turns	200 degrees	200 degrees
Current consumption	17 mA or less (When 24 VDC is ON)		25 mA or less (When 24 VDC is ON)		17 mA or less (When 24 VDC is ON)		
Max. operating pressure	0.2 MPa						

Note 1) When using an ejector, there is no problem if pressure of 0.5 MPa is applied for 1 second or less.

Note 2) X129 is for Series ZYX3000 and X130 is for Series ZYY3000.

How to Order Electronic Vacuum Pressure Switch

ZSE1 - 00 - 15 □ - X 130

Output specifications

14	NPN open collector, single output Analog, no output, 3 turn setting
15	NPN open collector, single output Analog, no output, 200 degree setting
16	NPN open collector, double output Analog, no output, 3 turn setting
17	NPN open collector, double output Analog, no output, 200 degree setting
18	NPN open collector, single output Analog, with output, 3 turn setting
19	NPN open collector, single output Analog, with output, 200 degree setting
55	PNP open collector, single output Analog, no output, 200 degree setting

Compatible model

129	For Series ZYX3000
130	For Series ZYY3000

Wiring specifications

Nil	Grommet type	Lead wire length 0.6 m
L		Lead wire length 3 m
C	Connector type	Lead wire length 0.6 m
CL		Lead wire length 3 m
CN		Without connector

With connector/How to Order

- Without lead wires (1 connector and 4 sockets) ----- ZS-20-A
- With lead wires ----- ZS-20-5A-□

Note) When ordering a switch with 5 m lead wires, enter the part numbers for both a switch without connector and lead wires with connector.

Example) ZSE1-00-15CN-X129 ----- 1 pc.
ZS-20-5A-50 ----- 1 pc.

Lead wire length	
Nil	0.6 m
30	3 m
50	5 m

How to Set the Pressure

- The ON pressure is set with the pressure setting trimmer. High vacuum settings are obtained by turning it clockwise.
- When setting, use a flat head screw driver which fits the slot in the trimmer, and turn it gently with your finger tips.

ZSE1-□□-14/-15/-18/-19

- Hysteresis can be set using the hysteresis setting trimmer. The setting is increased by turning it clockwise, and the range is 1 to 10% of the ON pressure.
- When the hysteresis setting trimmer is moved after setting the ON pressure, it must be set again.

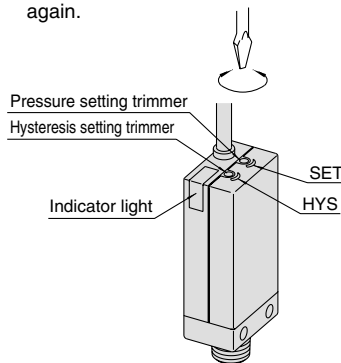

ZSE1-□□-16/-17

- OUT1 (white lead wire, red LED) can be set with pressure setting trimmer 1 (SET1).
- OUT2 (green lead wire, green LED) can be set with pressure setting trimmer 2 (SET2).

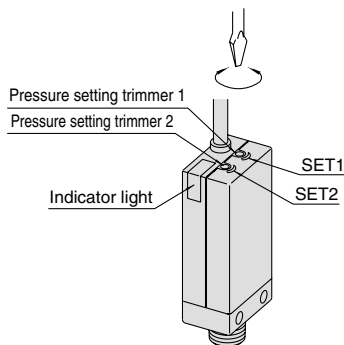

- When using to confirm adsorption, set to the minimum vacuum pressure at which adsorption is possible. If set below this valve, the switch will turn ON even when adsorption has failed or is insufficient. Also take note that if the setting is too high, the switch may not turn ON even with good adsorption.

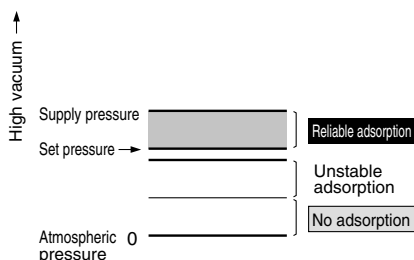

How to Use the Connector

1. Attaching and detaching connectors

- To install the connector, hold the lever and connector unit between your fingers and insert it straight onto the pins. Then lock it by pressing the pawl of the lever into the slot on the housing.
- To remove the connector, pull it straight out while pressing the lever down with your thumb to release the pawl from the slot.

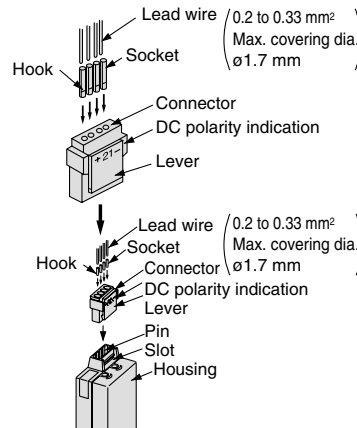

2. Crimping of lead wire and socket

Strip 3.2 to 3.7 mm at the end of the wire, place the exposed core wire into the socket properly and crimp with a crimping tool. When this is done, be sure that the lead wire covering does not get into the core wire crimping area. (Crimping tool: Model DXT170-75-1)

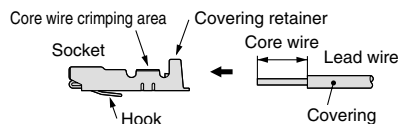

3. Attaching and detaching of socket to connector with lead wire

• Attaching

Insert the sockets into the square holes of the connector (with +, 1, 2, - indication), and continue to push the sockets all the way in until they lock by hooking into the seats in the connector. (When they are pushed in their hooks open and they are locked automatically.) Then confirm that they are locked by pulling lightly on the lead wires.

• Detaching

To detach a socket from a connector, pull out the lead wire while pressing the socket's hook with a stick having a thin tip (about 1 mm). If the socket will be used again, first spread the hook outward.

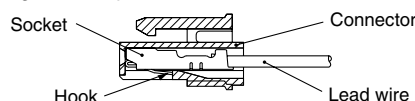

Hysteresis

Hysteresis is the difference between the pressure at which the output signal turns ON and the pressure at which it turns OFF. It turns ON at the set pressure.

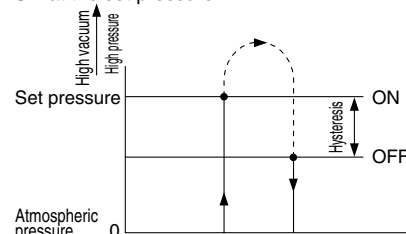

Internal Circuit and Wiring Example

ZSE1-□□-14, -15

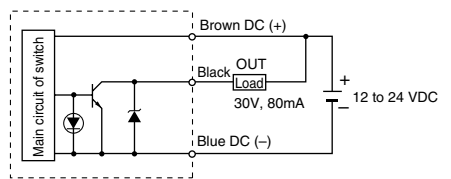

ZSE1-□□-16, -17

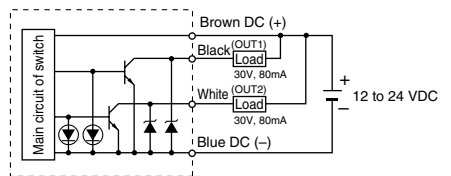

ZSE1-□□-18, -19

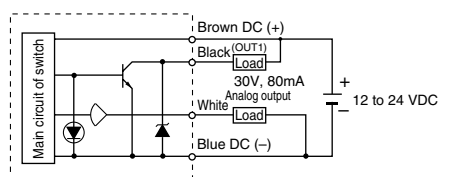

ZSE1-□□-55

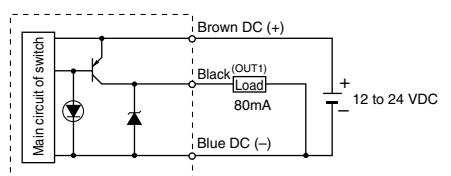

ZA

ZX

ZR

ZM

ZMA

ZQ

ZH

ZU

ZL

ZY□

ZF□

ZP□

SP

ZCUK

AMJ

AMV

AEP

HEP

Related Equipment

Series ZYY/ZYX

Construction

ZYY3000

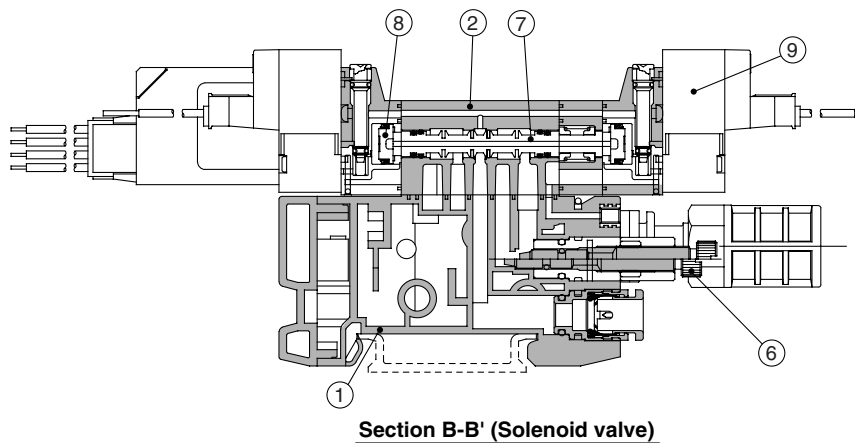
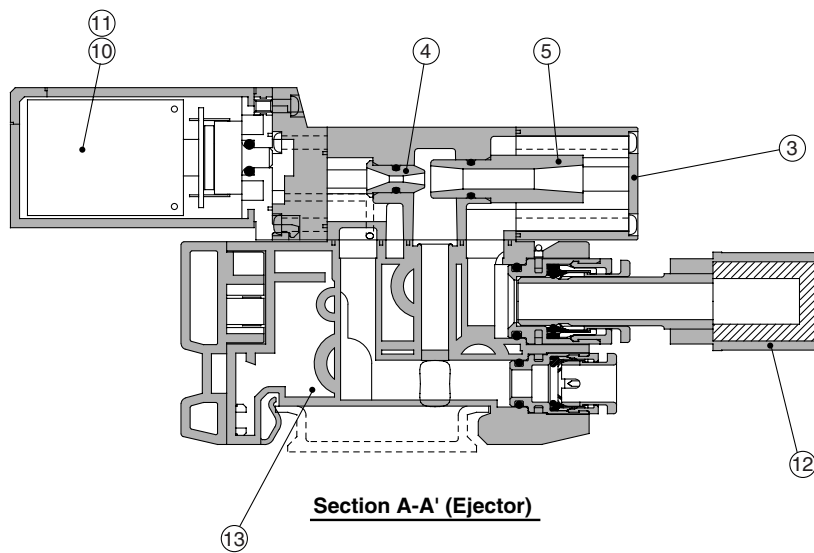
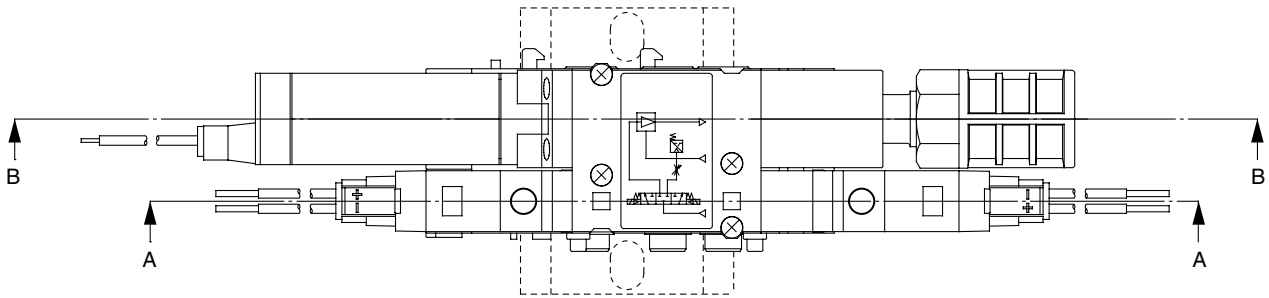

Component Parts

No.	Description	Material	Note
1	Manifold block	Resin	Urban white
2	Body	Zinc die-casted	Urban white
3	Silencer cover	Resin	Urban white
4	Nozzle	Aluminum alloy	
5	Diffuser	Aluminum alloy	
6	Needle	Stainless steel	
7	Spool	Aluminum alloy	
8	Piston	Resin	

Replacement Parts

No.	Description	Part no.
9	3 port solenoid valve	SY114-□□□
10	Vacuum switch	ZSE1-00-□□□-X130
11	End plate assembly	P44027A (Without a switch)
12	Silencer	AN203-KM8
13	Non plug assembly	ZYY3000-NPA

Construction

ZYX3000

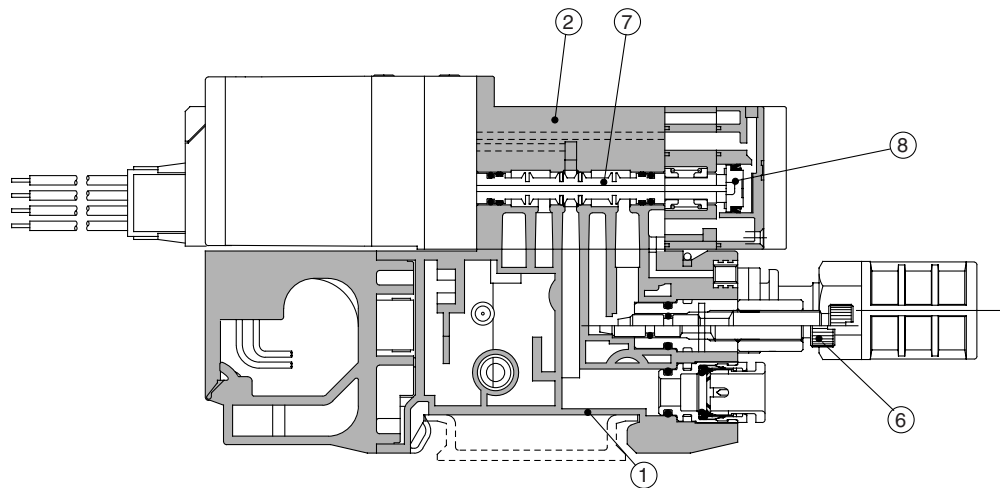
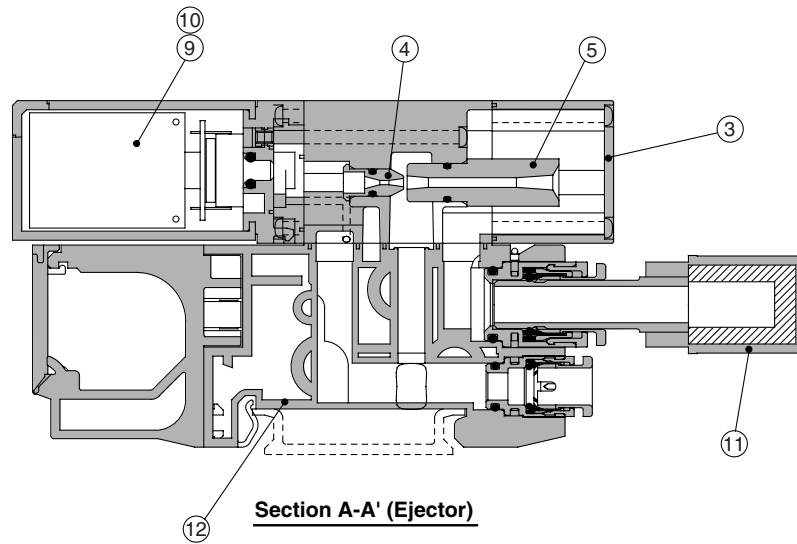
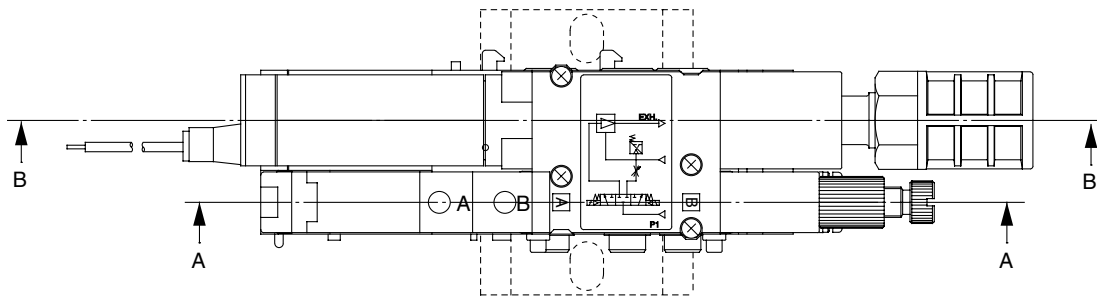

ZA
ZX
ZR
ZM
ZMA
ZQ
ZH
ZU
ZL
ZY□
ZF□
ZP□
SP
ZCUK
AMJ
AMV
AEP
HEP
Related Equipment

Component Parts

No.	Description	Material	Note
1	Manifold block	Resin	Urban white
2	Body	Zinc die-casted	Urban white
3	Silencer cover	Resin	Urban white
4	Nozzle	Aluminum alloy	
5	Diffuser	Aluminum alloy	
6	Needle	Stainless steel	
7	Spool	Aluminum alloy	
8	Piston	Resin	

Replacement Parts

No.	Description	Part no.
9	Vacuum switch	ZSE1-00-□□□-X129
10	End plate assembly	P440119A (Without a switch)
11	Silencer	AN203-KM8
12	Plug assembly	ZYY3000-PA

Series ZYY/ZYX

Exhaust Characteristics/Flow Characteristics The flow rate characteristics correspond to a supply pressure of 0.45 MPa.

ZY^{Y3}_{X3} □□□□□-07S

Exhaust Characteristics

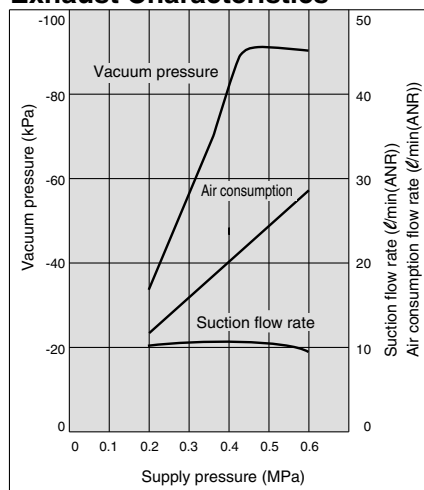

Flow Characteristics

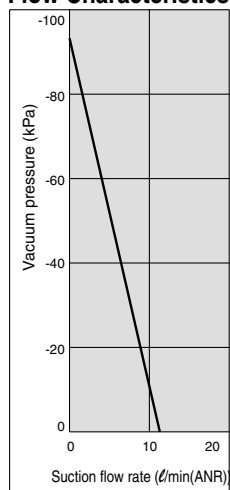

ZY^{Y3}_{X3} □□□□□-07L

Exhaust Characteristics

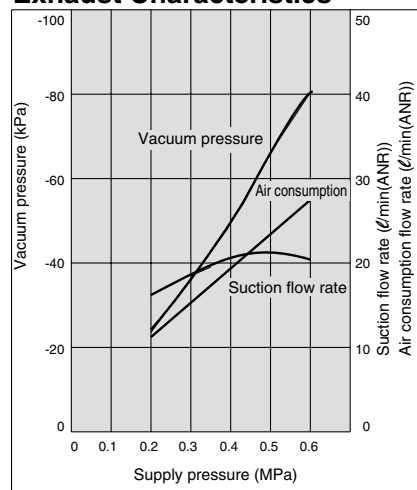

Flow Characteristics

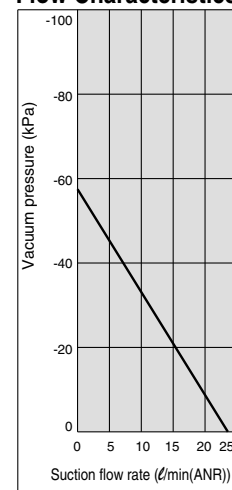

ZY^{Y3}_{X3} □□□□□-10S

Exhaust Characteristics

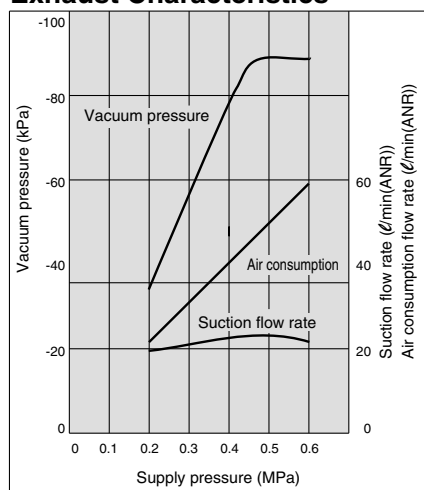

Flow Characteristics

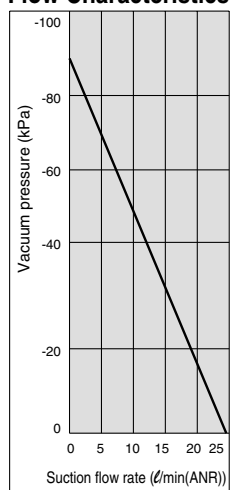

ZY^{Y3}_{X3} □□□□□-10L

Exhaust Characteristics

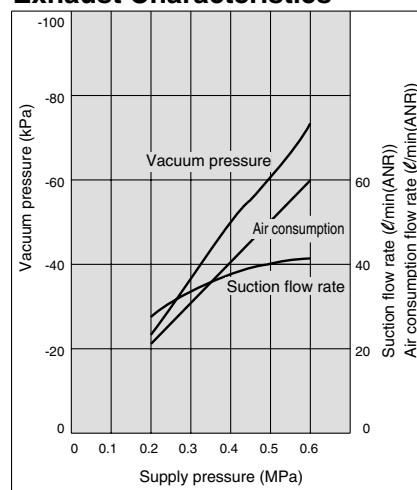

Flow Characteristics

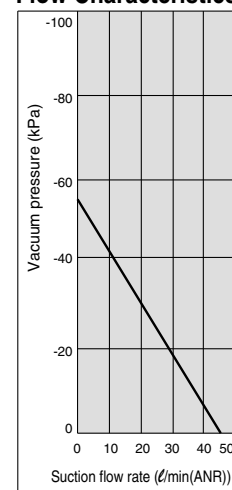

How to Read Flow Characteristics Graph

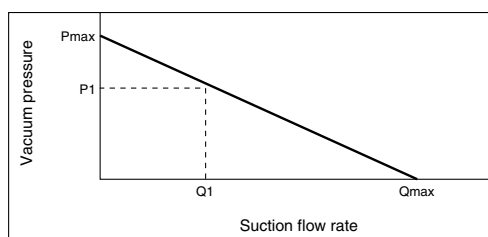

The flow rate characteristics indicate the relationship between the vacuum pressure and the suction flow rate of the ejector, and show that when the suction flow rate changes the vacuum pressure also changes. In general, this indicates the relationship at the ejector's standard operating pressure. In the graph, Pmax indicates the maximum vacuum pressure, and Qmax indicates the maximum suction flow rate. These are the values that are published as specifications in catalogs, etc. The methods for changing the vacuum pressure will be explained in order.

1. If the ejector's suction port is closed and sealed tight, the suction flow rate becomes "0" and the vacuum pressure increases to the maximum (Pmax).
2. If the suction port is opened gradually and air is allowed to flow (the air leaks), the inlet flow rate increases and the vacuum pressure decreases. (the condition of P1 and Q1)
3. If the suction port is opened completely, the suction flow rate increases to the maximum (Qmax), while the vacuum pressure then drops almost to "0" (atmospheric pressure).

In this way, when the suction flow rate changes the vacuum pressure also changes. In other words, when there is no leakage at the vacuum port (vacuum piping), the vacuum pressure increases to the maximum, but the vacuum pressure drops as the amount of leakage increases, and when the amount of leakage and the maximum suction flow rate become equal, the vacuum pressure decreases nearly to "0". When adsorbing workpieces which are permeable or subject to leakage, etc., caution is required as the vacuum pressure will not be very high.

Ejector Valve Dimensions

ZYY3□LZ-□□1-E□C

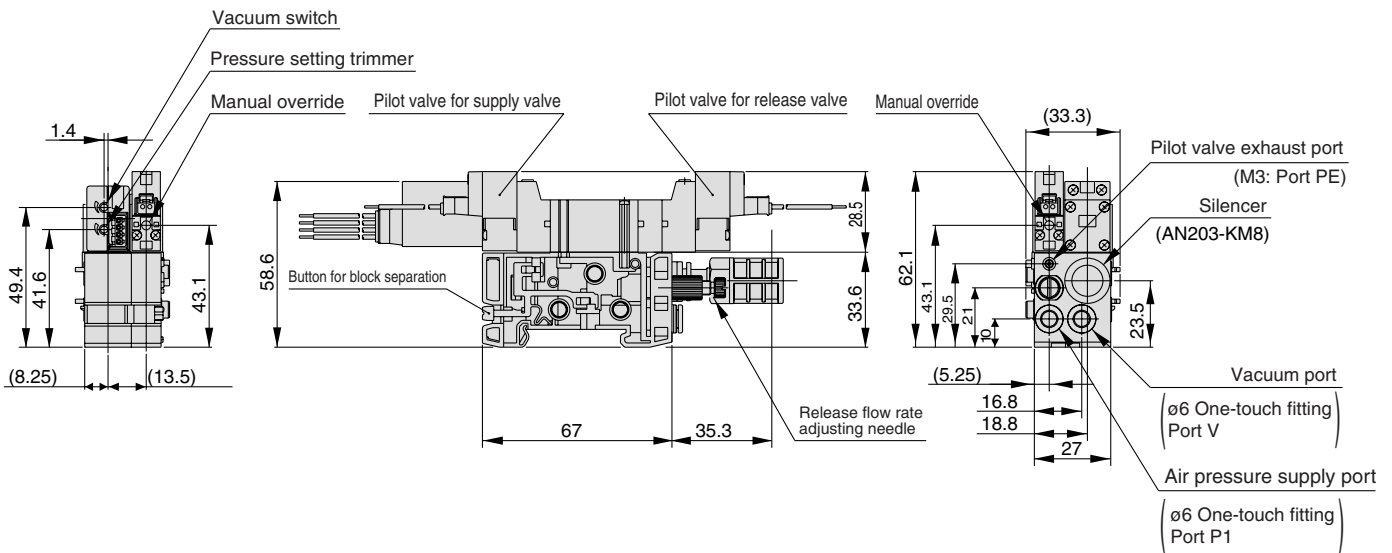
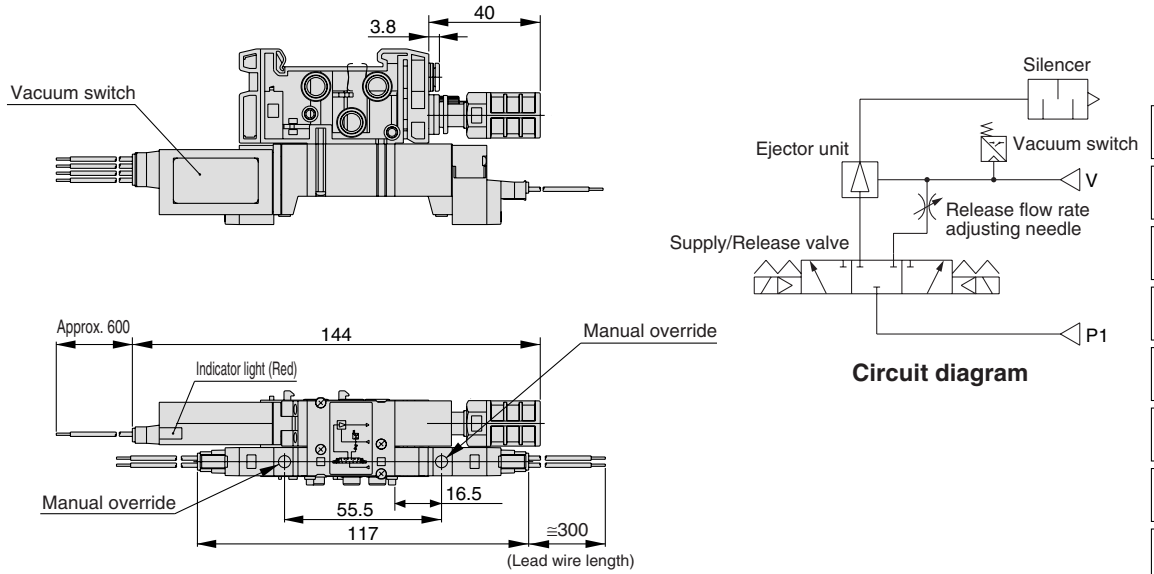

ZYY3□LZ-□S1(Specifications without vacuum switch)

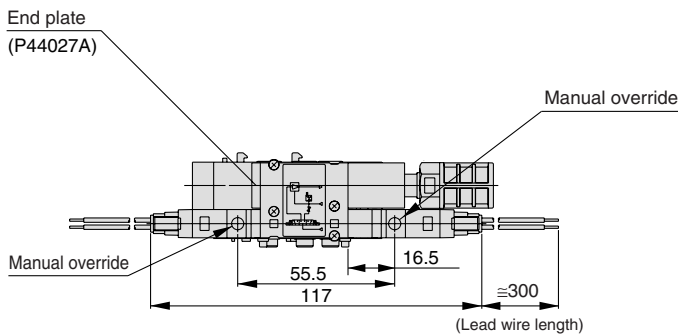

ZA
ZX
ZR
ZM
ZMA
ZQ
ZH
ZU
ZL
ZY□
ZF□
ZP□
SP
ZCUK
AMJ
AMV
AEP
HEP
Related Equipment

Series ZYY/ZYX

Ejector Valve Dimensions

ZYY3□LZ-□□1-E□C-MN

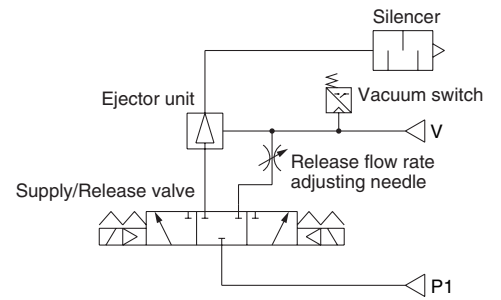

Circuit diagram

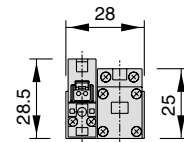
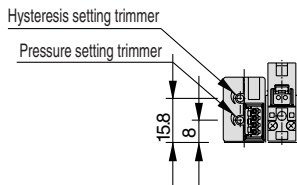
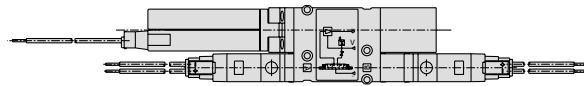
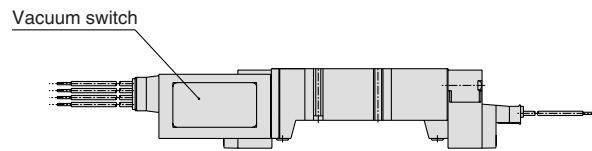

Accessory (packed together)

1. Silencer (AN203-KM8...1 pc.)

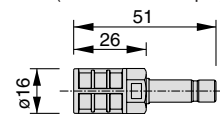

2. Mounting bolt nut (M2 x 0.4 x 20...4 pcs.)

Ejector Valve Dimensions

ZYX3□LOZ-□□1-E□C

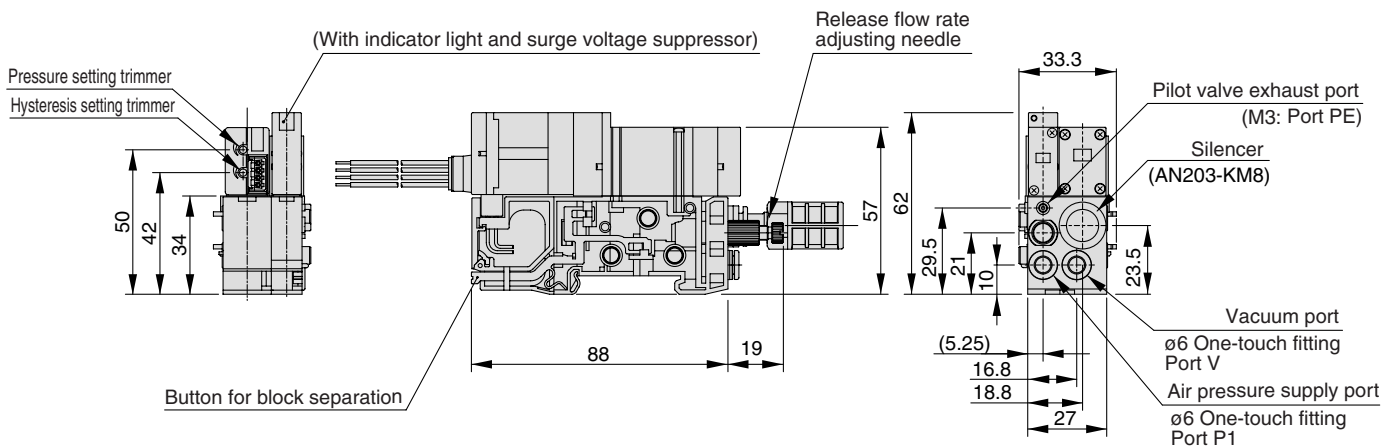
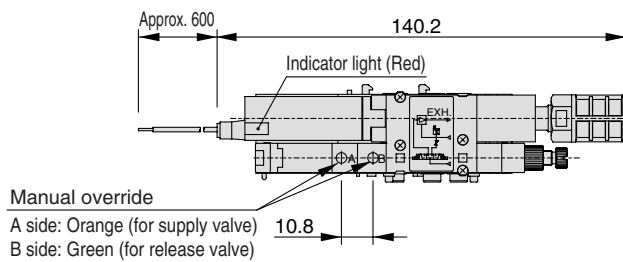
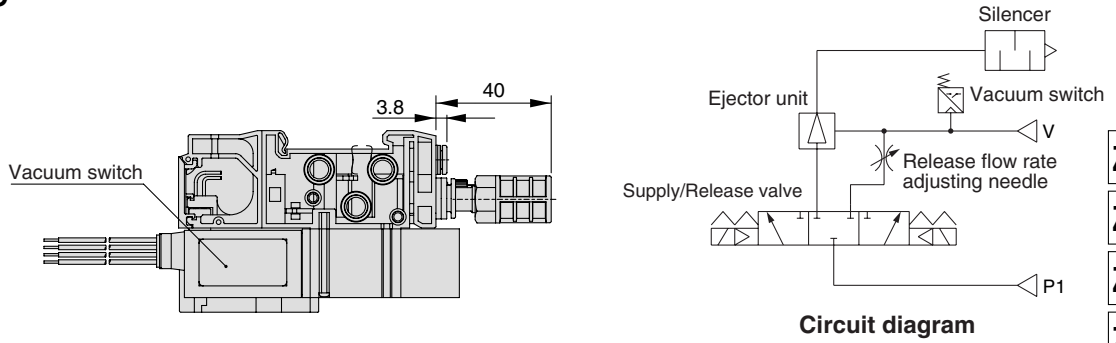

ZYX3□LOZ-□S1(Specifications without vacuum switch)

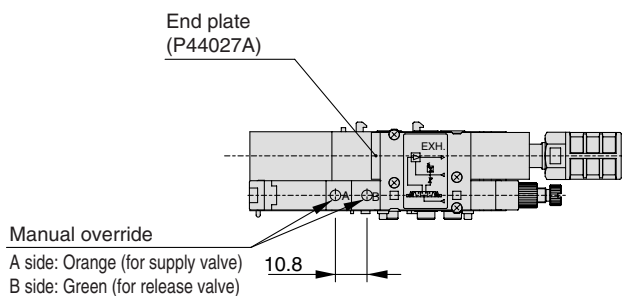

ZA
ZX
ZR
ZM
ZMA
ZQ
ZH
ZU
ZL
ZY□
ZF□
ZP□
SP
ZCUK
AMJ
AMV
AEP
HEP
Related Equipment

Series ZYY/ZYX

Ejector Valve Dimensions

ZYX3□L-□S-E□C-F

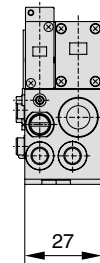
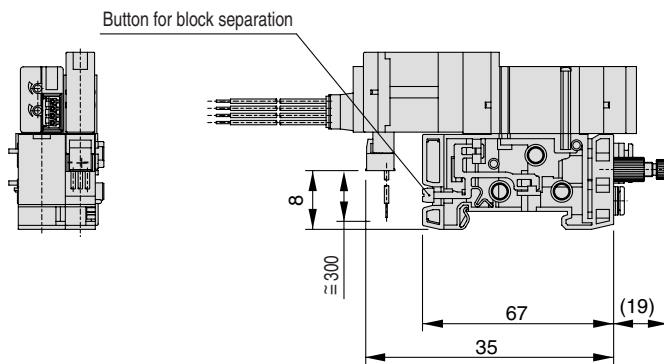
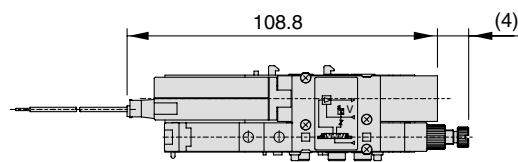
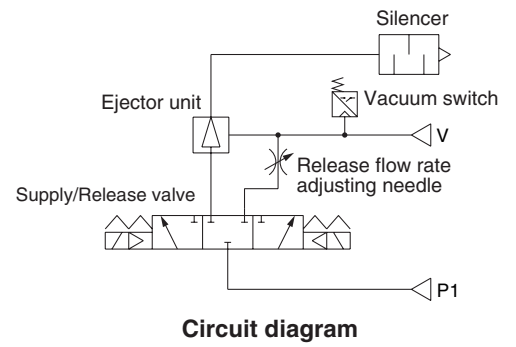
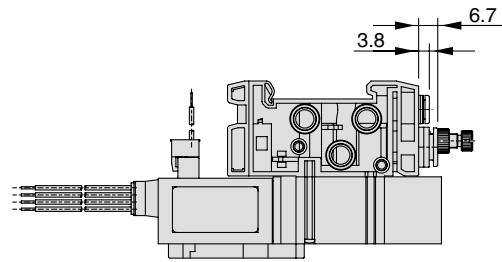

Ejector Valve Dimensions

ZYX3□L-□S1-E□C-FMN

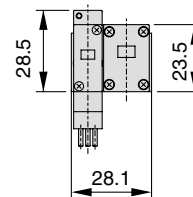
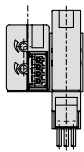
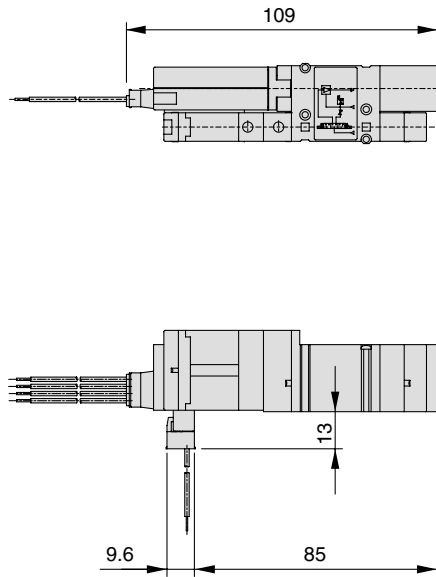
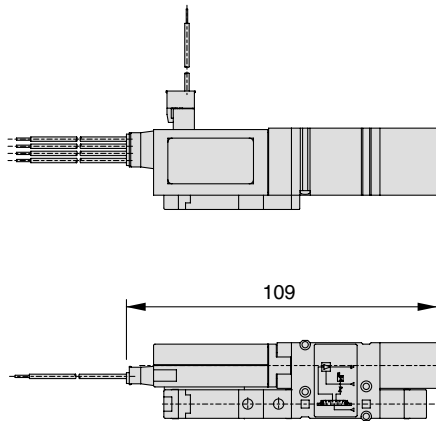
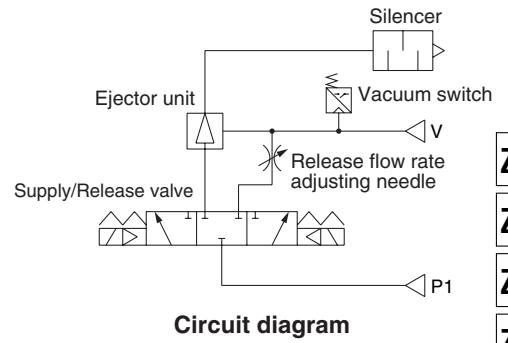

Accessory (packed together)

1. Silencer (AN203-KM8...1 pc)

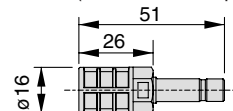

2. Mounting bolt nut (M2 x 0.4 x 25...4 pcs.)

ZA

ZX

ZR

ZM

ZMA

ZQ

ZH

ZU

ZL

ZY□

ZF□

ZP□

SP

ZCUK

AMJ

AMV

AEP

HEP

Related
Equipment

Series ZYY/ZYX

Ejector Valve Dimensions

ZYX3□L-□S1-E□C-MN

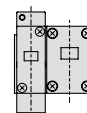
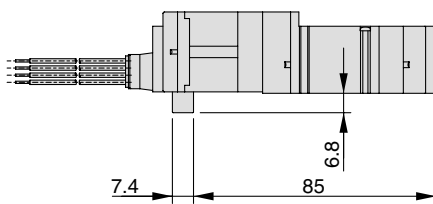
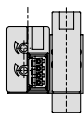
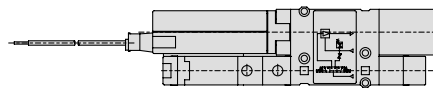
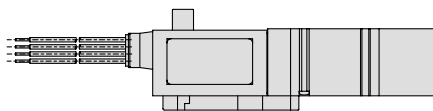
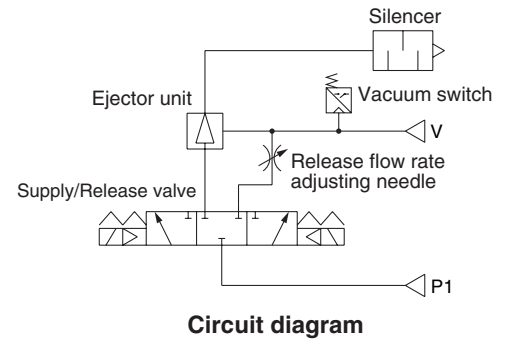

Accessory (packed together)

1. Silencer (AN203-KM8...1 pc)

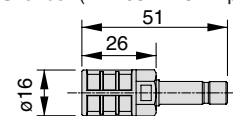

2. Mounting bolt nut (M2 x 0.4 x 25...4 pcs.)

Ejector Valve Dimensions

ZYY3000-PA (Plug-in assembly)

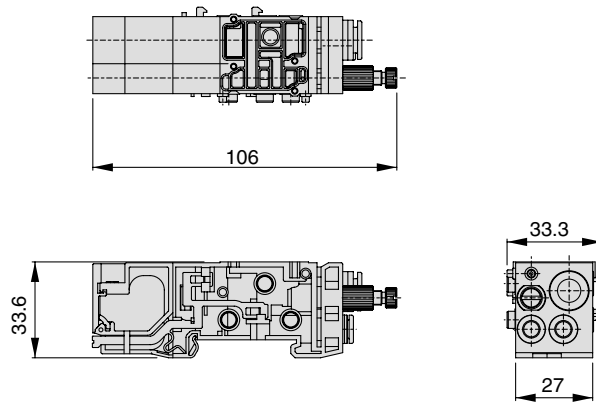

ZYY3000-NPA (Non plug-in assembly)

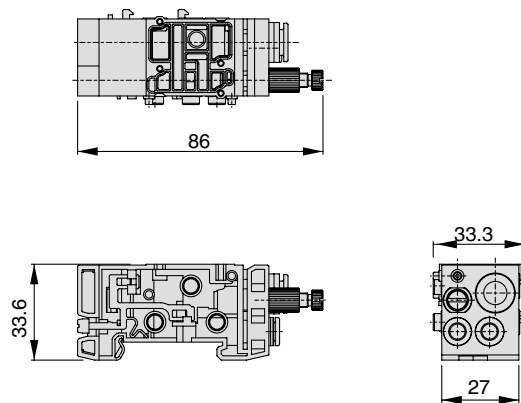

ZA
ZX
ZR
ZM
ZMA
ZQ
ZH
ZU
ZL
ZY□
ZF□
ZP□
SP
ZCUK
AMJ
AMV
AEP
HEP
Related Equipment

Series ZYY/ZYX

Dimensions of DIN Rail Mounting Unit for ZYY3000/ZYX3000 Manifold

The length of the standard accessory DIN rail is calculated with the formula below.

Manifold overall length (L3) = (27 x Number of ejector valve stations) + (10.5 x Number of solenoid valve stations) + (16.5 x Number of supply/exhaust block stations) + C1 [mm]

Note) In the case of ejector valves only (without solenoid valves), calculate the number of solenoid valve stations and supply/exhaust block stations as "0".

Number of mounting holes (N) = (L3/12.5 + 1): Decimal fractions are truncated

DIN rail overall length (L1) = N x 12.5 + 23 [mm]

Mounting screw length (L2) = L1 - 10.5 [mm]

Rail length on one side (L4) = (L1 - L3)/2 [mm]

C1 Value Selection

(mm)

Separate wiring type	45	33
Connector box type	45- ^A _{NA}	86
D-sub connector 25 pin type	45F	54
Flat cable type	45P□	
Terminal block 9 pole type	45T	
Terminal block 18 pole type	45T1	75
Serial transmission type	45S□	81.8
	45S1□	94.3
	45S2	132
	45S3	126

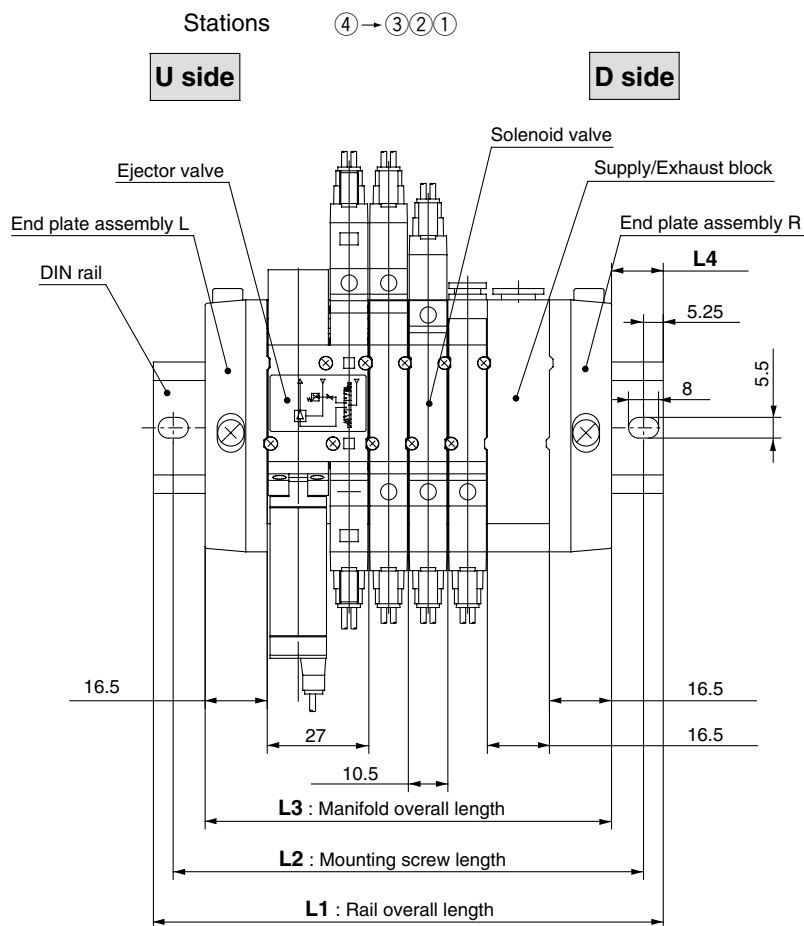

Indication example

In the case of
ZZYY3-45-04D-C6
 *SY3140-5LZ
 *SY3240-5LZ
 *SY3340-5LZ
 *ZYY35LZ-10S-E15C
 the dimensions are
L1 = 135.5 mm
L2 = 125 mm
L3 = 108 mm
L4 = 13.75 mm



Series ZYY/ZYX Electronic Pressure Switches Specific Product Precautions 1

Be sure to read before handling.

Design/Selection

⚠ Warning

1. Use with the specified voltage.

Use with voltage outside of the specifications can cause malfunction or switch damage, as well as electrocution and fire hazard, etc.

2. Never use a load which exceeds the maximum load capacity.

This may damage a switch or reduce its service life.

3. Do not use a load that generates surge voltage.

Although a zener diode for surge protection is connected at the output side of a switch, damage may still occur if the surge is applied repeatedly.

When a load, such as a relay or solenoid, which generates surge is directly driven, use a type of switch having a built-in surge absorbing element.

4. Be sure to confirm the fluid specifications.

Since switches do not have explosion-proof construction, do not use flammable gases or fluids. This may cause a fire or explosion.

5. Be certain to observe the regulating pressure range and maximum operating pressure.

Operation at a pressure outside of this range can cause failure. In addition, the switch will be broken if operated above the maximum operating pressure.

Mounting

⚠ Warning

1. Do not use until you can verify that equipment can operate properly.

Verify correct mounting by suitable function and leakage inspections after air and power are connected following mounting, maintenance or conversions.

2. Do not drop or bump.

Do not drop, bump or apply excessive impact (1000 m/s²) when handling. Even if the switch body is not damaged, the switch may suffer internal damage that will lead to malfunction.

3. Hold the product from the body side when handling.

The tensile strength of the power cord is 49 N, and pulling it with a force greater than this can cause failure. Hold by the body when handling.

4. Turn the setting trimmer gently using a watchmakers screw driver.

Turn the setting trimmer gently using a watchmakers screw driver. Do not turn beyond the stoppers located at both sides. If the trimmer is broken, adjustment will be impossible.

5. Pressure port

Do not insert wire, etc, from the pressure port. This will damage the pressure sensor, making it impossible to obtain normal operation.

Wiring

⚠ Warning

1. Confirm wire colors and terminal numbers when wiring is performed.

Since incorrect wiring can lead to breakage or failure of the switch as well as malfunction, perform wiring after confirming wiring colors and terminal numbers with the instruction manual.

2. Avoid repeatedly bending or stretching lead wires.

Broken lead wires will result from applying bending stress or stretching force to the lead wires. In the event that lead wires are damaged creating a possibility of malfunction, replace the entire product. (For cases in which the lead wires cannot be replaced through grommets.)

3. Confirm proper insulation of wiring.

Be certain that there is no faulty wiring insulation (contact with other circuits, ground fault, improper insulation between terminals, etc.). Damage may occur due to excess current flow into a switch.

4. Do not wire power lines or high voltage lines.

Wire separately from power lines or high voltage lines, avoiding parallel wiring or wiring in the same conduit with these lines. Control circuits, including switches, may malfunction due to noise from these other lines.

5. Do not allow short circuiting of loads.

Use caution, as switches will be damaged instantly if a load is short circuited. Be especially careful not to reverse the power supply line (Brown) and the output line (Black).

Pressure Source

⚠ Warning

1. Observe the fluid and ambient temperature ranges.

The fluid and ambient temperatures are 5 to 50°C. Moisture in circuits can freeze at 5°C or below, causing damage to O-rings, and malfunction. Consider measures to prevent freezing. The installation of an air dryer is recommended to remove drainage and moisture from circuits.

Furthermore, even though the ambient temperature range remains within specifications, do not operate in locations where there are abrupt temperature changes.

2. Vacuum pressure switches

There will be no change in performance if a pressure of 0.5 MPa or less is applied for 1 second or less (when releasing a vacuum), but care should be taken that pressures of 0.2 MPa or more are not regularly applied.

ZA

ZX

ZR

ZM

ZMA

ZQ

ZH

ZU

ZL

ZY□

ZF□

ZP□

SP

ZCUK

AMJ

AMV

AEP

HEP

Related
Equipment



Series ZYY/ZYX Electronic Pressure Switches Specific Product Precautions 2

Be sure to read before handling.

Operating Environment

⚠ Warning

1. Never use in an atmosphere of explosive gases.

The structure of pressure switches is not intended to prevent explosion. Never use in an atmosphere with an explosive gas since this may cause a serious explosion.

2. Do not use in locations with sources of surge generation.

When equipment that generates a large amount of surge (solenoid type lifters, high frequency induction furnaces, motors, etc.) is located in the area around a pressure switch, there is a danger of deterioration or damage to the switch's internal circuit elements. Therefore, implement surge countermeasures at the sources, and avoid the mixing and touching of lines.

3. Operating environment

Since the electronic pressure switch is basically an open type, avoid use in locations where there is a scattering of water or oil, etc.

Maintenance

⚠ Warning

1. Perform maintenance regularly.

It may otherwise not be possible to assure safety due to unexpected malfunction or misoperation, etc.

2. When used in an interlock circuit

When used in an interlock circuit, provide multiple interlock circuits as a precaution against failure, and also perform regular inspections to confirm normal operation.

3. When the body requires cleaning

Use a soft cloth to clean the case. In case of heavy soiling, wipe it off with a cloth soaked in a neutral detergent diluted with water after wringing it out thoroughly, and finish up by wiping with a dry cloth.

⚠ Precautions

Be sure to read before handling.

Refer to front matters 38 and 39 for Safety Instructions and pages 844 to 846 for Vacuum Equipment Precautions.

Piping

⚠ Caution

1. Connect the compressed air supply piping separately to the solenoid valves and ejector valves. Also, connect each ejector valve to separate piping system.

Operation of Ejector Valves

⚠ Caution

1. When the pilot valve for air supply is turned ON, the main valve switches, and vacuum is generated by the flow of compressed air from the nozzle to the diffuser.

When the pilot valve for vacuum release is turned ON, the main valve switches, and the vacuum is quickly released as air passes through the release flow adjustment needle and flows to the vacuum port.

When the pilot valve for air supply and the pilot valve for vacuum release are both OFF, the main valve is in a closed state in the center position.

Operating Environment

⚠ Caution

1. Avoid use exposed to direct sunlight.

Solenoid Valves (Series SY3000/SX3000)

⚠ Caution

1. Refer to Best Pneumatics No. 1 and SMC's website for Specific Product Precautions for solenoid valves (Series SY3000/SX3000).

Serial Wiring

⚠ Caution

1. Serial wiring is possible only for the solenoid valve section.
Wire the vacuum switch separately.