

Liquid Collector Ejector Type **HEP500-04**



Resource Saving/Labor Saving — Collects and reuses leaked fluids such as valuable cutting oil and grinding oil

Collects leaked fluids such as valuable cutting oil and grinding oil.

This equipment collects cutting oil and grinding oil that sticks to and leaks from pumps or processed materials, shavings, etc.

No need for workers to carry out tasks such as collecting fluid.

Freedom from the troublesome task of collecting leaked fluid.

Compact – easy mounting and operation

This equipment is compact, uses minimal space, and not only are mounting and operation simple, but also maintenance is not needed.

Can be driven by an already-installed pump

Already-installed pumps can power these collectors. There is no need to provide a fresh source of energy.

Specifications

Model		HEP500-04	
Fluid		Water-soluble	Non-water soluble
Collected fluid		Cutting oil/Grinding oil	Cutting oil/Grinding oil
Minimum Operating pressure		20 kPa or more (0.02 MPa or more)	
Collected flow rate ℓ /min		0.8 to 2.7	0.01 to 1
Port size*	Liquid collector	IN	1/2 (Female thread)
		OUT	Nylon tube $\phi 12/\phi 9$
	Leaked fluid suction inlet	With fitting (H06-01)	
Strainer		With fitting (H06-02)	
Strainer filtration		60 mesh gauze	
Material	Liquid collector	Brass, Electroless Ni-P alloy plated	
	Strainer	Cast iron, Electroless Ni-P alloy plated	
Mass	Liquid collector	500 gf	
	Strainer	200 gf	

*Use nylon tube T0645 to connect the liquid collector with the strainer.

Application Example

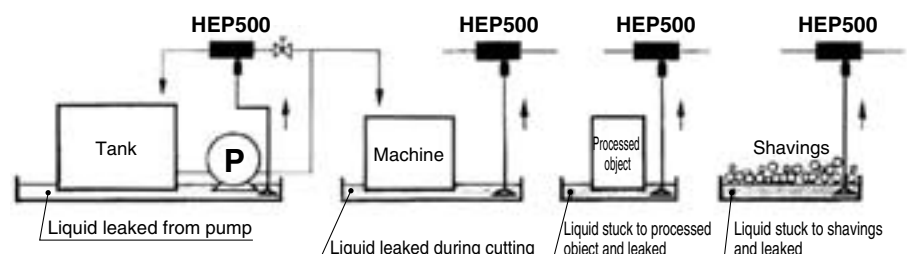

Flow Characteristics

Diluted water-soluble cutting oil

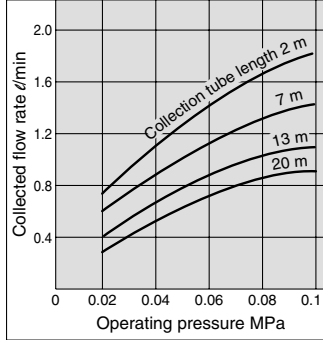

Non-water soluble cutting oil: Dynamic viscosity 20cSt

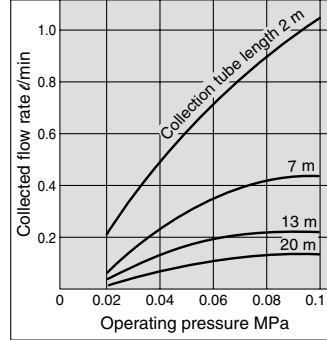

Non-water soluble cutting oil: Dynamic viscosity 50cSt

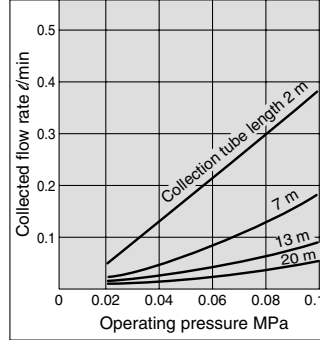

Operating pressure and operating flow rate

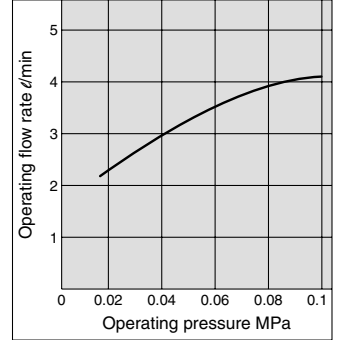

Conditions: 1. Lifting range 1m 2. Collection tube (T0645) length

Working Principle

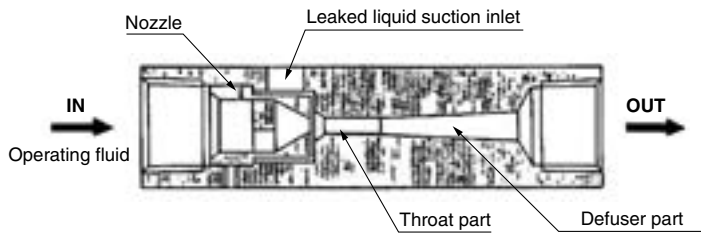

When the operating fluid is released from the IN side (nozzle, throat part, defuser part) at or above a certain flow rate, it causes a collision phenomenon in the throat part and negative pressure is generated. This negative pressure is used to suck up the leaked liquid and discharge it from the OUT side along with the operating fluid, returning it to the tank.

Piping

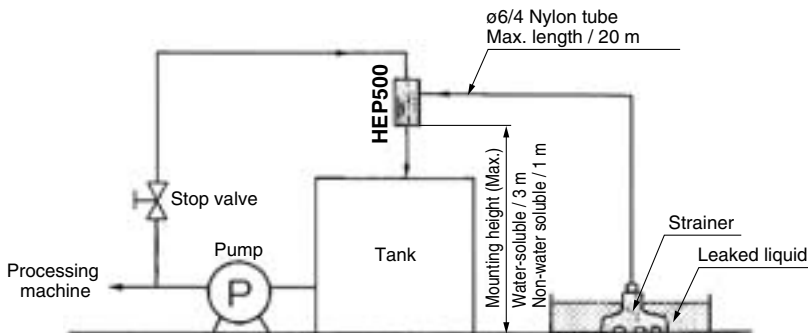

Dimensions

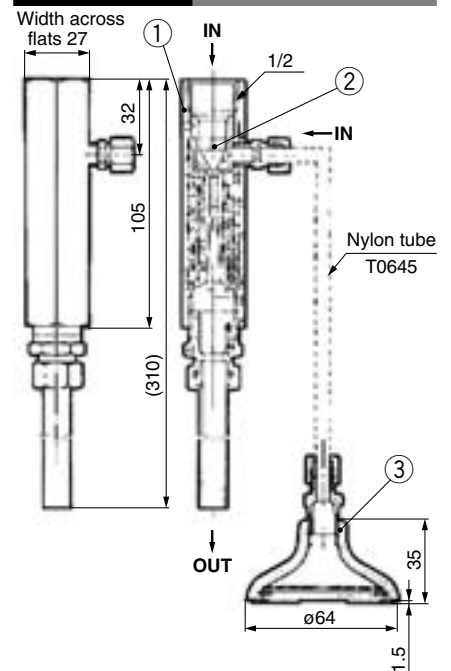

Main Parts

No.	Description	Material	Note
1	Body	Brass	Electroless nickel plated

Parts List

No.	Description	Material	Part no.
2	Nozzle assembly	Brass	P257021
3	Strainer body assembly	—	P257014A

Piping Precautions

1. Install a pipe that branches off from the pipes supplying cutting oil or grinding oil to the processing machinery, and connect it to the IN side of the liquid collector. Mounting a stop valve will make maintenance easier.
2. Mount the discharge port facing in a vertical or horizontal direction.
3. When mounting the liquid collector, the mounting height is 3 m for water-soluble liquids and 1 m for non-water soluble liquids. However, the collector's performance will decline if it is mounted in a high place, so mount the collector in as low a place as possible.
4. Use a nylon tube to connect the liquid collector with the strainer. The size should be $\phi 6$ or $\phi 4.5$ and length should be a maximum of 20 m, but the collector's performance will decline as the tube gets longer, so be sure to use as short a connecting tube as possible.
5. Connect the nylon tube (200 mm) leading from the OUT side of the collector to a tank. When doing so, be sure the end of the tube does not come in contact with liquids. If this occurs, back pressure may be generated, which results in sub-optimal performance.

Handling Precautions

During collection of leaked liquid, if there is a decline in performance, or a total failure to collect liquid occurs, check for the following potential sources of trouble.

1. When the nozzle is clogged : If the nozzle is clogged, loosen the set screw (M3 x 0.5 hexagon socket head screw), remove the nozzle from the body and clean it.
2. When the strainer gauze is clogged : After removing the C-type snap ring (nominal size 52), remove the gauze and clean it.
3. Fluids : The fluids used are water-soluble or non-water soluble. When using fluids other than these, please consult with SMC separately.

ZA
ZX
ZR
ZM
ZMA
ZQ
ZH
ZU
ZL
ZY□
ZF□
ZP□
SP
ZCUK
AMJ
AMV
AEP
HEP
Related Equipment