

## 外形尺寸图

●HMF-12CS标准

 410页

●带开关

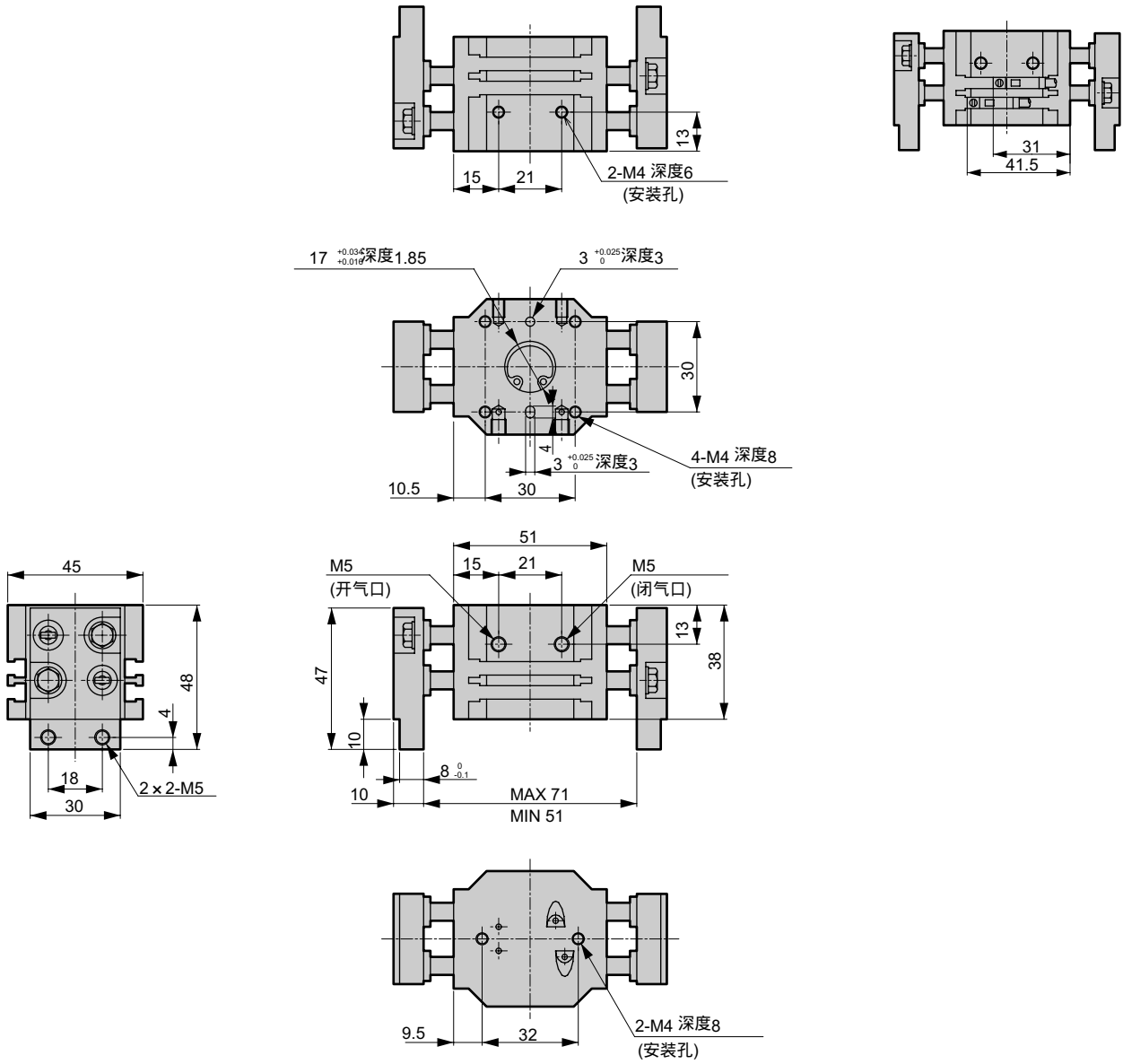

### 外形尺寸图

●HMF-16CS标准

 410页

●带开关

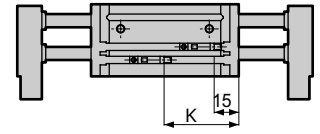
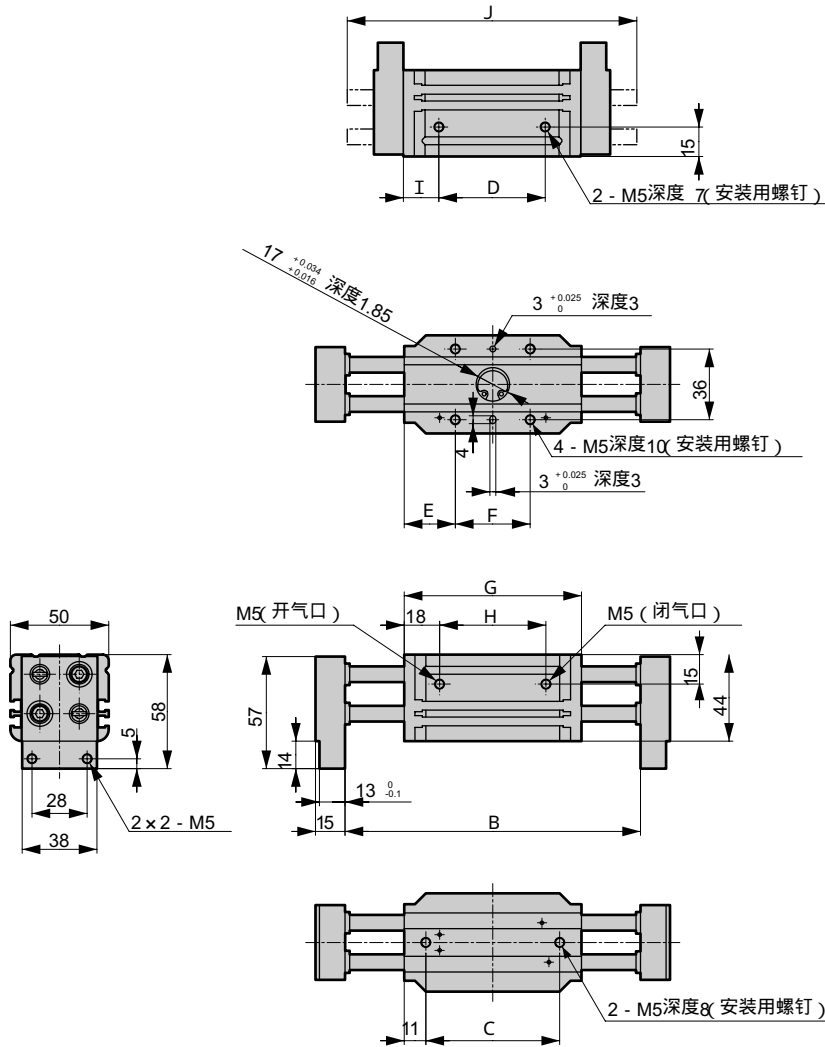

| 符号      | B   |     | C  | D  | E  | F  | G   | H  | I  | J   | K    |
|---------|-----|-----|----|----|----|----|-----|----|----|-----|------|
|         | MAX | MIN |    |    |    |    |     |    |    |     |      |
| 标准(无符号) | 90  | 60  | 38 | 28 | 11 | 38 | 60  | 24 | 16 | -   | 30   |
| L1      | 150 | 90  | 68 | 54 | 26 | 38 | 90  | 54 | 18 | 147 | 45.5 |
| L2      | 186 | 106 | 84 | 70 | 26 | 54 | 106 | 70 | 18 | 183 | 55.5 |

- RRC
- GRC
- RV3
- NHS
- HR
- LN
- FH100
- HAP
- BSA2
- BHA·BHG
- LHA
- LHAG
- HKP
- HLA·HLB
- HLAG·HLBG
- HEP
- HCP
- HMF**
- HMFB
- HFP
- HLC
- HGP
- FH500
- HBL
- HDL
- HMD
- HJL
- BHE
- CKG
- CK
- CKA
- CKS
- CKF
- CKJ
- CKL2
- CKL2 - -HC
- CKH2
- CKLB2
- NCK·SCK·FCK
- FJ
- FK
- ABP
- 小卡爪
- 小型蟹型平行卡爪

## 外形尺寸图

●HMF-20CS标准·L1·L2

 410页

●带开关

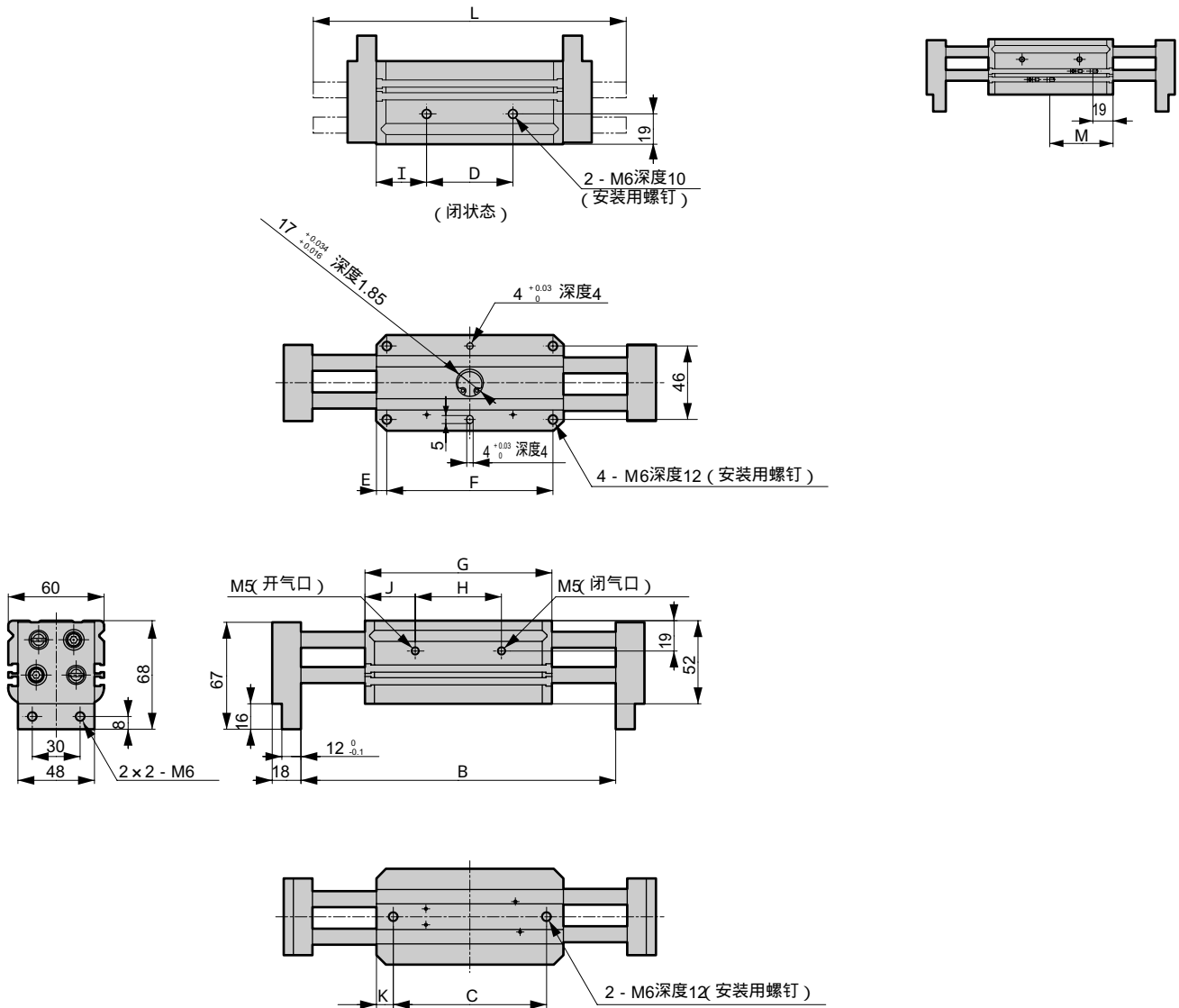

| 符号      | B   |     | C   | D  | E   | F   | G   | H  | I    | J    | K    | L   | M    |
|---------|-----|-----|-----|----|-----|-----|-----|----|------|------|------|-----|------|
|         | MAX | MIN |     |    |     |     |     |    |      |      |      |     |      |
| 标准(无符号) | 114 | 74  | 56  | 38 | 9   | 56  | 74  | 34 | 18   | 20   | 9    | -   | 39.5 |
| L1      | 197 | 117 | 96  | 54 | 6.5 | 104 | 117 | 54 | 31.5 | 31.5 | 10.5 | 196 | 59.5 |
| L2      | 233 | 133 | 112 | 70 | 6.5 | 120 | 133 | 70 | 31.5 | 31.5 | 10.5 | 232 | 69.5 |

### 外形尺寸图

●HMF-25CS标准·L1·L2

 410页

●带开关

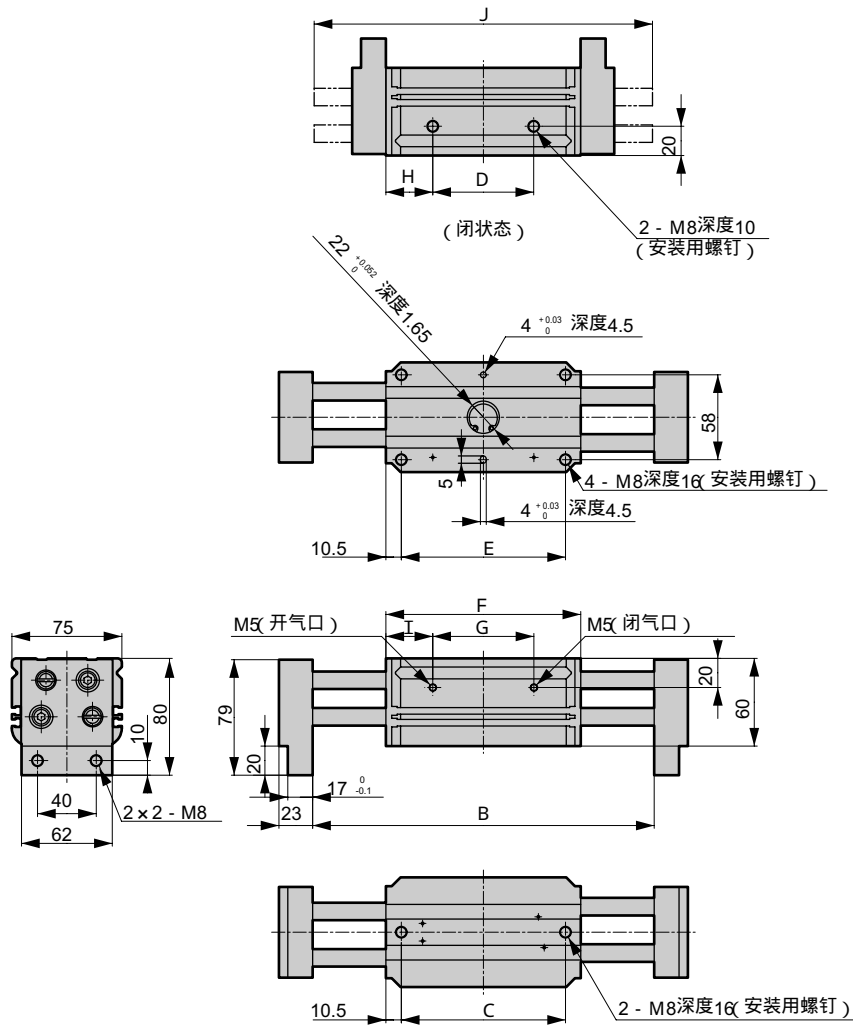

| 符号      | B   |     | C   | D  | E   | F   | G  | H    | I  | J   | K    |
|---------|-----|-----|-----|----|-----|-----|----|------|----|-----|------|
|         | MAX | MIN |     |    |     |     |    |      |    |     |      |
| 标准(无符号) | 141 | 91  | 70  | 48 | 70  | 91  | 41 | 21.5 | 25 | -   | 50.5 |
| L1      | 233 | 133 | 112 | 69 | 112 | 133 | 69 | 32   | 32 | 231 | 72.5 |
| L2      | 271 | 151 | 130 | 87 | 130 | 151 | 87 | 32   | 32 | 269 | 85.5 |

- RRC
- GRC
- RV3
- NHS
- HR
- LN
- FH100
- HAP
- BSA2
- BHA·BHG
- LHA
- LHAG
- HKP
- HLA·HLB
- HLAG·HLBG
- HEP
- HCP
- HMF**
- HMFB
- HFP
- HLC
- HGP
- FH500
- HLB
- HDL
- HMD
- HJL
- BHE
- CKG
- CK
- CKA
- CKS
- CKF
- CKJ
- CKL2
- CKL2 - -HC
- CKH2
- CKLB2
- NCK·SCK·FCK
- FJ
- FK
- ABP
- 小卡爪
- 小型蟹型平行卡爪

## 外形尺寸图

●HMF-32CS标准·L1·L2

 410页

●带开关

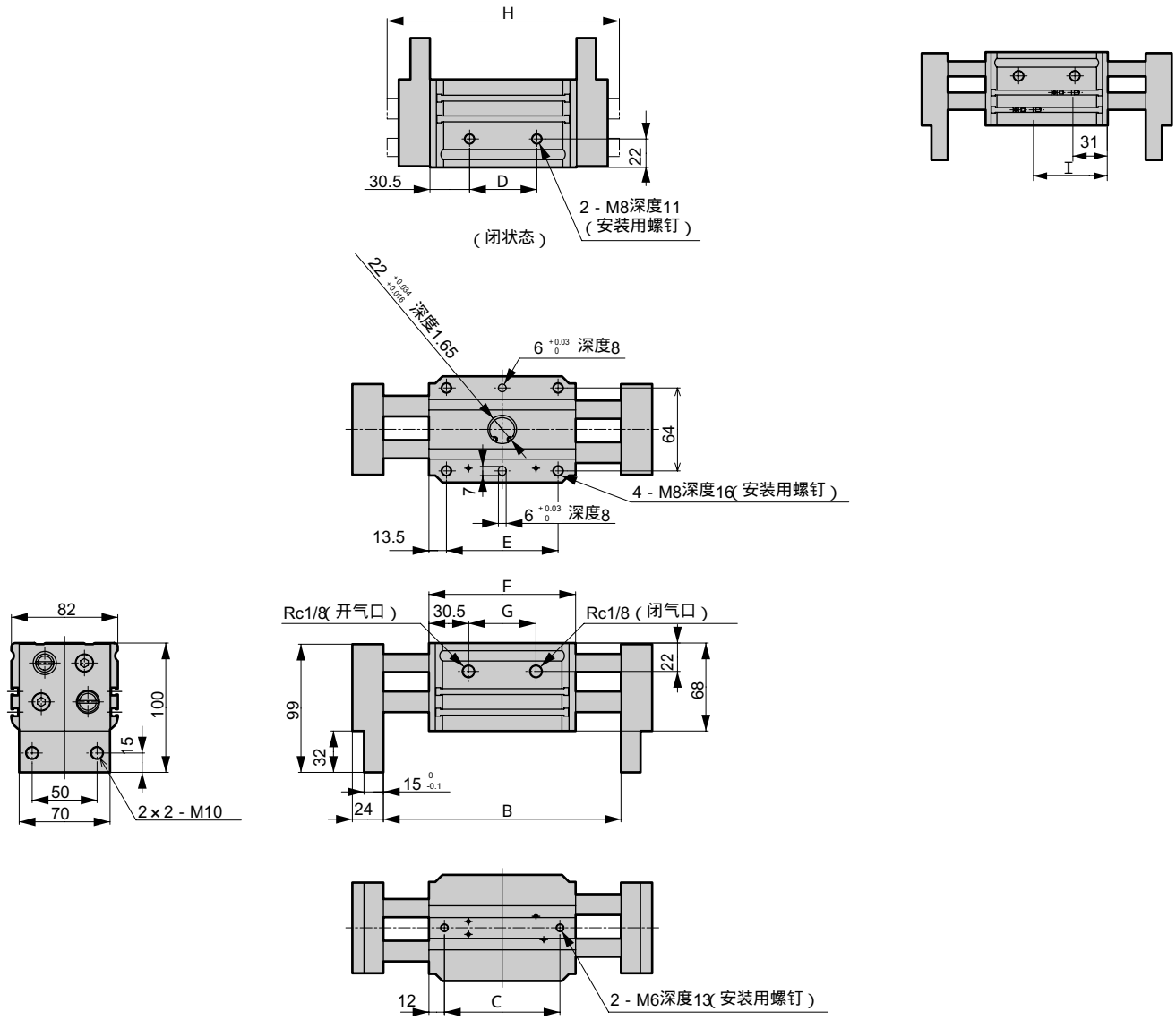

| 符号      | B   |     | C   | D   | E   | F   | G   | H   | I     |
|---------|-----|-----|-----|-----|-----|-----|-----|-----|-------|
|         | MAX | MIN |     |     |     |     |     |     |       |
| 标准(无符号) | 183 | 113 | 89  | 52  | 86  | 113 | 52  | 179 | 66.5  |
| L1      | 274 | 154 | 130 | 93  | 127 | 154 | 93  | 270 | 91.5  |
| L2      | 354 | 194 | 170 | 133 | 167 | 194 | 133 | 350 | 111.5 |

### 外形尺寸图

●HMF-40CS标准·L1·L2

 410页

●带开关

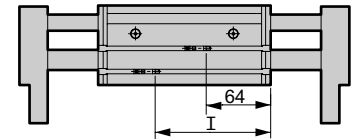
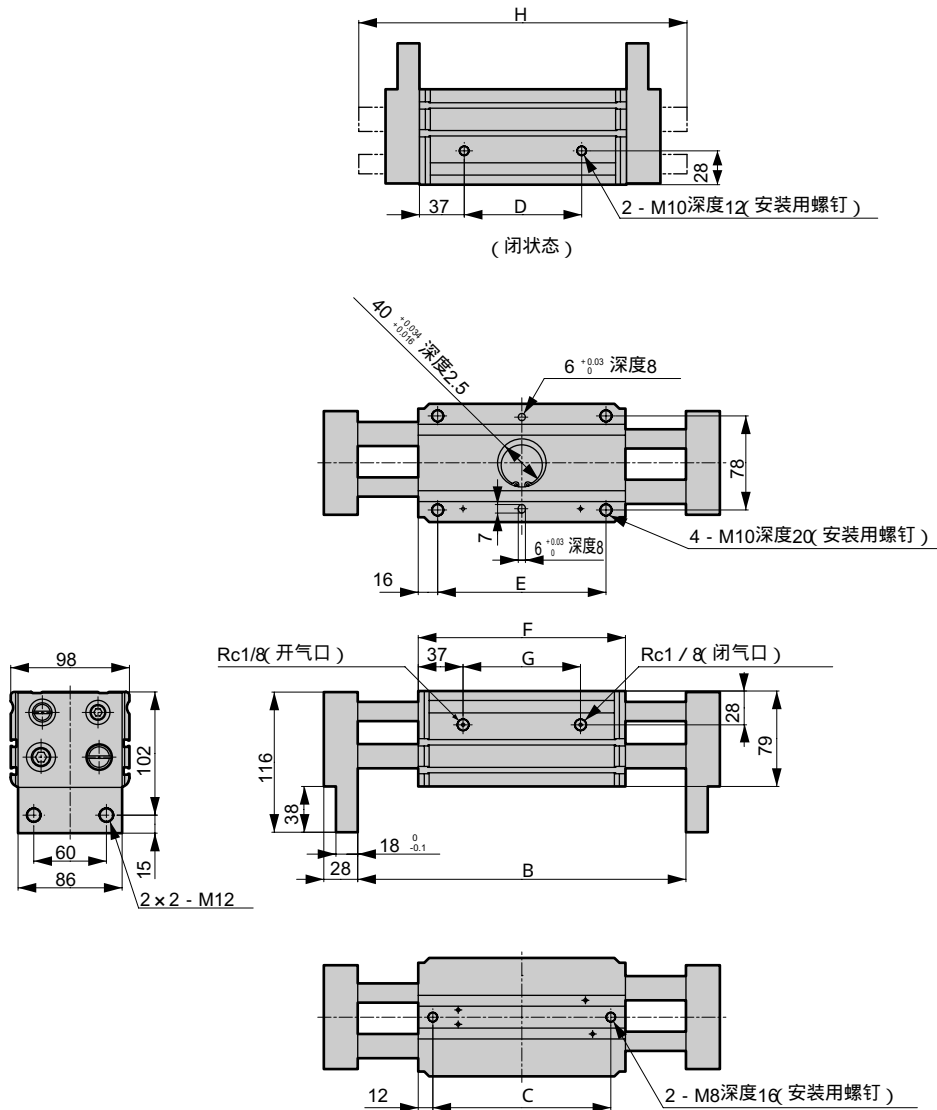

- RRC
- GRC
- RV3
- NHS
- HR
- LN
- FH100
- HAP
- BSA2
- BHA·BHG
- LHA
- LHAG
- HKP
- HLA·HLB
- HLAG·HLBG
- HEP
- HCP
- HMF**
- HMFB
- HFP
- HLC
- HGP
- FH500
- HBL
- HDL
- HMD
- HJL
- BHE
- CKG
- CK
- CKA
- CKS
- CKF
- CKJ
- CKL2
- CKL2 - -HC
- CKH2
- CKLB2
- NCK·SCK·FCK
- FJ
- FK
- ABP
- 小型卡爪
- 蟹型平行卡爪

| 符号      | B   |     | C   | D   | E   | F   | G   | H   | I     |
|---------|-----|-----|-----|-----|-----|-----|-----|-----|-------|
|         | MAX | MIN |     |     |     |     |     |     |       |
| 标准(无符号) | 271 | 171 | 147 | 97  | 139 | 171 | 97  | 271 | 114.5 |
| L1      | 361 | 201 | 177 | 127 | 169 | 201 | 127 | 361 | 144.5 |
| L2      | 434 | 234 | 210 | 160 | 202 | 234 | 160 | 434 | 164.5 |