

Features

- Once the solenoid is de-energized, it requires power to be restored to the solenoid then the valve to be manually reset. Ideal for controlling critical processes
- Designed to meet vibration and/or shock per ISA specification S71.03C2
- Handles aggressive atmosphere per salt resistance testing (ASTM B117)
- Most hardware is stainless steel, and all aluminum components are hard anodized and Nituff® coated
- Manual reset housing is sealed with closed-cell CR sponge rubber and equipped with sintered bronze breather to prevent accumulation of condensation
- Last chance filter installed in auxiliary air port of the pilot valve

Nituff is a registered trademark of Nimet Industries, Inc.

Construction

Valve Parts in Contact with Fluids			
Main Valve			
Body	Brass / Stainless Steel		
Disc	303 Stainless Steel		
Seats	Phosphor Bronze		
Springs	17-7 PH Stainless Steel		
Seals	Buna-N / FKM		
Air Operator Diaphragm	FMQ		
Bearing Screw	430 Stainless Steel		
Lever	302 Stainless Steel		
Pilot Valve	AC 10.1 W	DC 1.4 W	
Body	Brass / 303 Stainless Steel	Brass / 303 Stainless Steel	
Shading Coil	Silver / Coper	Not Applicable	
Seals	NBR	Buna-N/PTFE	
Core Tube	305 Stainless Steel	305 Stainless Steel	
Core and Plugnut	430F Stainless Steel	430F Stainless Steel	
Core Guide	CA	CA	
Core Springs	302 & 17-7PH Stainless Steel	302 Stainless Steel	

Electrical

Standard Coil and Class of Insulation	Watt Rating and Power Consumption				Spare Coil Part Number			
	DC Watts	AC			General Purpose		Explosionproof	
		Watts	VA Holding	VA Inrush	AC	DC	AC	DC
F	-	10.1	25	76	238610	-	238614	-
F	1.4	-	-	-	-	-	274714-902-D*	-

Standard Voltages: 24, 120, 240, 480 volts AC, 60 Hz. 12, 24 volts DC.
 Must be specified when ordering. * 24 VDC. For other voltages contact factory.

Solenoid Enclosures

Standard: Explosionproof and Watertight, Types 3, 3S, 4, 4X, 6, 6D, 7, and 9.

Approvals

CSA certified and UL listed General Purpose Valve (pilot).

ATEX/IECEX certified with prefix "EV" as listed. Refer to Optional Features Electrical Section for details.

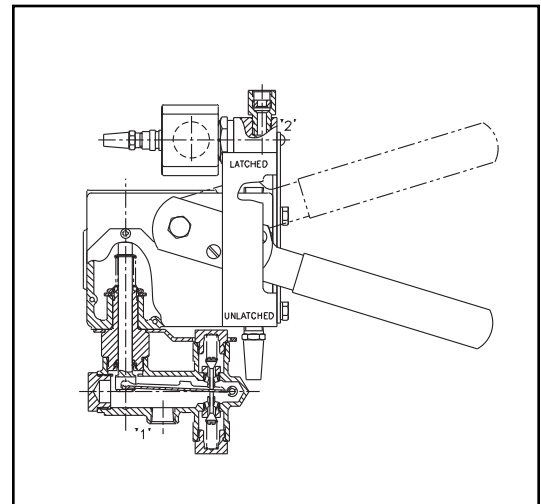
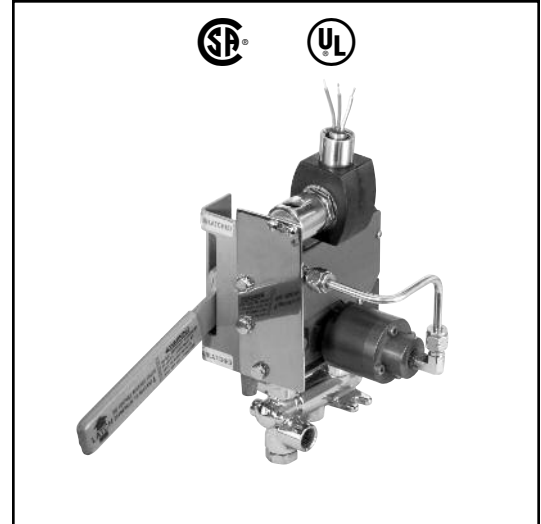

SPECIAL SERVICE PILOT

Options

Position indicator switch (suffix SP);

Redundant pilot valves.

Contact factory for ordering information.

Operation Alternatives

Electrically Tripped – With the pilot valve solenoid de-energized, the handle is raised manually and latches the operator in the "up" (latched) position. Upon energizing the pilot valve solenoid, the latch is tripped returning the operator to the "down" (unlatched) position.

No Voltage Release – With the pilot valve solenoid energized, the handle is raised manually and latches the operator in the "up" (latched) position. Upon loss of voltage, the latch is tripped returning the operator to the "down" (unlatched) position.

Once tripped, the lever may be cycled causing the valve discs to open and close.

Specifications (English units)

Pipe Size (in)	Orifice Size (in)	Cv Flow Factor	Operating Pressure Differential (psi)			Fluid Temp. °F		Max. Ambient Temp. °F	Catalog Number	Const. Ref.	Body Material	Pilot Construction	Watt Rating/ Class of Coil Insulation per Solenoid	
			Pilot Min.	Pilot Max.	Main Max.	Min.	Max.						AC	DC
3/2 High-Shock Manual Reset Valves														
3/8	1/4	0.45	25	125	125	-40	140	140	EV8308G385 ①	1	Brass	No Voltage Release (NVR)	-	1.4/F
3/8	1/4	0.45	25	125	125	-40	140	140	EV8310G385 ①	1	Brass	Electrically Tripped (TSO)	-	1.4/F
3/8	1/4	0.45	25	125	125	-4	200	125	EV8308G085 ①	1	Brass	No Voltage Release (NVR)	10.1/F	-
3/8	1/4	0.45	25	125	125	-4	200	125	EV8310G085 ①	1	Brass	Electrically Tripped (TSO)	10.1/F	-
3/8	1/4	0.45	25	125	125	-40	140	140	EV8308G386 ①	2	Stainless Steel	No Voltage Release (NVR)	-	1.4/F
3/8	1/4	0.45	25	125	125	-40	140	140	EV8310G386 ①	2	Stainless Steel	Electrically Tripped (TSO)	-	1.4/F
3/8	1/4	0.45	25	125	125	-4	200	125	EV8308G086 ①	2	Stainless Steel	No Voltage Release (NVR)	10.1/F	-
3/8	1/4	0.45	25	125	125	-4	200	125	EV8310G086 ①	2	Stainless Steel	Electrically Tripped (TSO)	10.1/F	-

① ATEX/IECEx certified with prefix "EV".

Specifications (Metric units)

Pipe Size (in)	Orifice Size (in)	Kv Flow Factor (m³/h)	Operating Pressure Differential (bar)			Fluid Temp. °C		Max. Ambient Temp. °F	Catalog Number	Const. Ref.	Body Material	Pilot Construction	Watt Rating/ Class of Coil Insulation per Solenoid	
			Pilot Min.	Pilot Max.	Main Max.	Min.	Max.						AC	DC
3/2 High-Shock Manual Reset Valves														
3/8	1/4	0.39	1.7	9	9	-40	60	60	EV8308G385 ①	1	Brass	No Voltage Release (NVR)	-	1.4/F
3/8	1/4	0.39	1.7	9	9	-40	60	60	EV8310G385 ①	1	Brass	Electrically Tripped (TSO)	-	1.4/F
3/8	1/4	0.39	1.7	9	9	-20	93	52	EV8308G085 ①	1	Brass	No Voltage Release (NVR)	10.1/F	-
3/8	1/4	0.39	1.7	9	9	-20	93	52	EV8310G085 ①	1	Brass	Electrically Tripped (TSO)	10.1/F	-
3/8	1/4	0.39	1.7	9	9	-40	60	60	EV8308G386 ①	2	Stainless Steel	No Voltage Release (NVR)	-	1.4/F
3/8	1/4	0.39	1.7	9	9	-40	60	60	EV8310G386 ①	2	Stainless Steel	Electrically Tripped (TSO)	-	1.4/F
3/8	1/4	0.39	1.7	9	9	-20	93	52	EV8308G086 ①	2	Stainless Steel	No Voltage Release (NVR)	10.1/F	-
3/8	1/4	0.39	1.7	9	9	-20	93	52	EV8310G086 ①	2	Stainless Steel	Electrically Tripped (TSO)	10.1/F	-

① ATEX/IECEx certified with prefix "EV".

Flow Diagrams

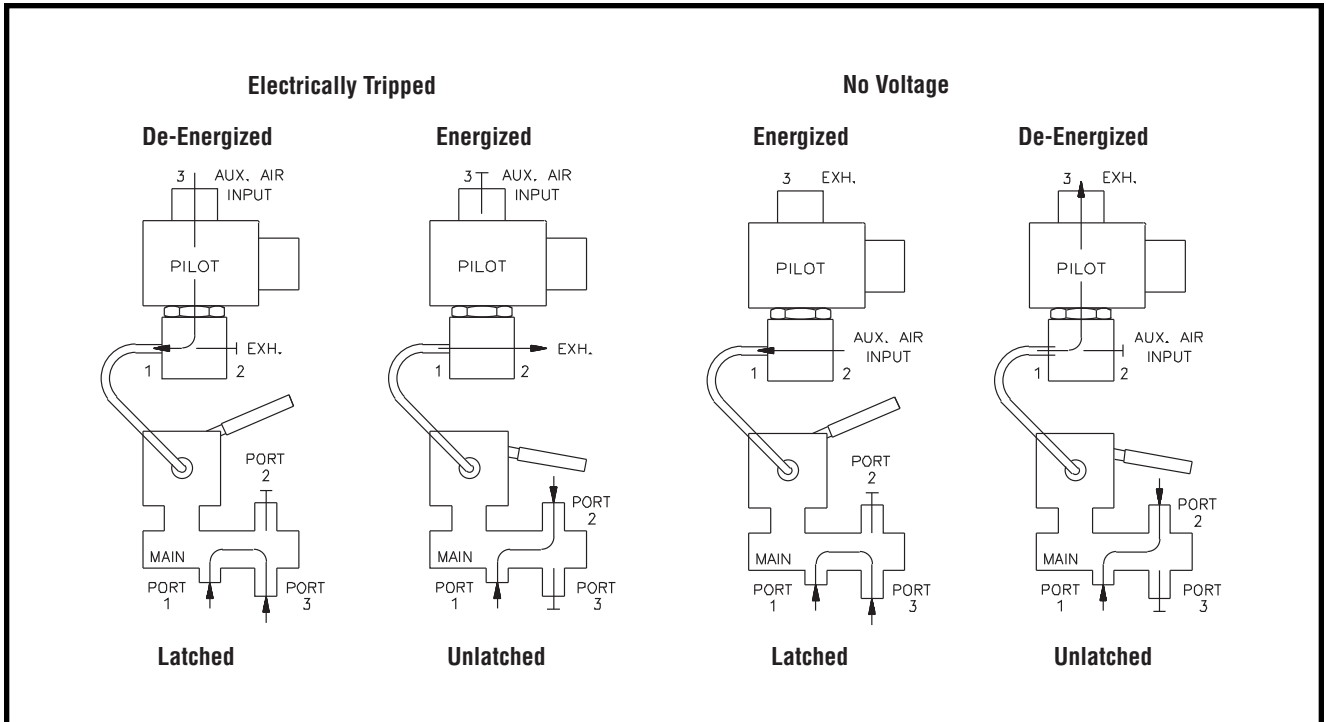

Dimensions inches (mm)

Const. Ref.		A	Body Material
1	in	10.04	Brass
	mm	255	
2	in	11.83	Stainless Steel
	mm	301	

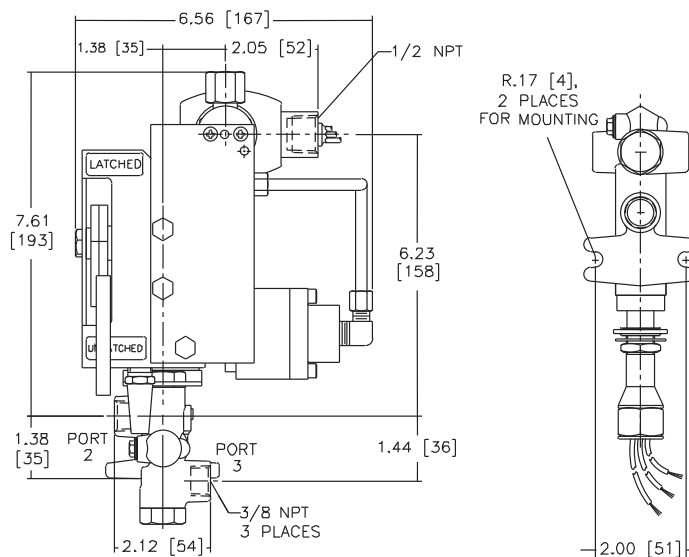
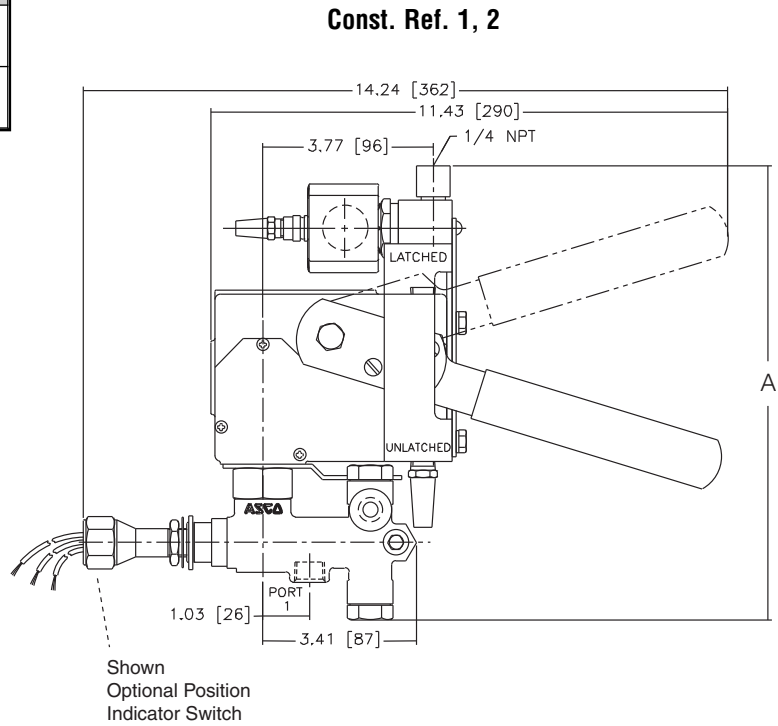

IMPORTANT: Mount with manual reset assembly vertical and upright.

