

Features

- Flow rates adjustable between 0% and 100% of rating
- Flow rate can also be regulated by a range of electrical inputs (sensors, transmitters, PLC, etc.) via an ASCO Electronic Control Unit or similar circuit
- Suitable for use in air/gas, low vacuum service, as well as to precisely control flow of water

Construction

Valve Parts in Contact with Fluids			
	8202		8203
Body	Brass	303 Stainless Steel	Brass
Seals and Disc/Diaphragm*	FKM		NBR
Core Tube	305 Stainless Steel		
Core and Plugnut	430F Stainless Steel		
Springs	302 Stainless Steel		
Rider Rings	PTFE		
Breaker Piece	Brass	303 Stainless Steel	Brass

Electrical

Standard voltage: 24 VDC

Coil: Molded Class F

Coil resistance: 25 Ohm at 68°F (20°C)

Operating current: 100 - 500 mA

Recommended PWM frequency: 300 Hz Air/Gas; 200 Hz Water/Light Oil

Hysteresis: <5% (<7.5% for 8203 Valves) ①

Repeatability: <3% (<1% for 1/8" NPT Valves) ①

Sensitivity: <2% (<1% for 1/8" NPT Valves) ①

① Based on ASCO Electronic Control Unit at constant differential pressure.

Solenoid Enclosures

Standard: RedHat II Class F coil with DIN connection (meets ISO 4400/DIN 43650A standards). For 22.6 watt solenoids.

Optional: For Class H coil, use prefix "SV" (for use with customer supplied electronics): General Purpose and Watertight, Types 1, 2, 3, 3S, and 4X on 22.6 watt solenoids.

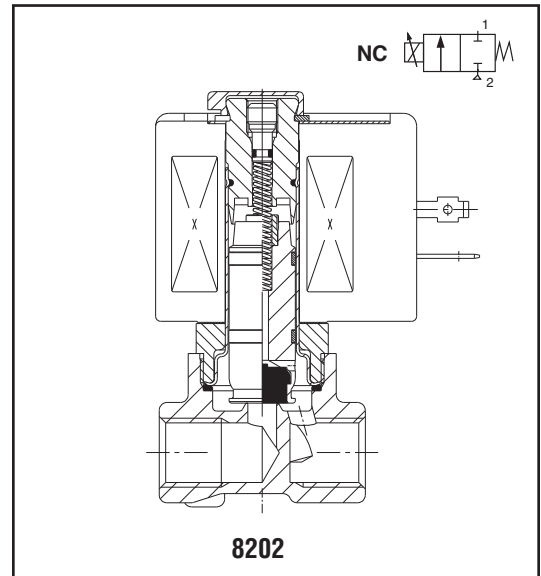

Nominal Ambient Temp. Ranges

14°F to 104°F (-10°C to 40°C) for 22.6 watt solenoid.

Approvals (8202 1/4" to 3/8" only)

UL Recognized Component with DIN solenoid (prefix SD or SV).

UL Listed with threaded conduit (no prefix)

CSA certified.

Note: The Electronic Control Unit (sold separately) is only compatible with DIN connectors

SPECIAL SERVICE VALVES

Specifications (English units)

Pipe Size (in)	Orifice Size (in)	Cv Flow Factor	Operating Pressure Differential (psi)			Max. Fluid Temp. °F	Catalog Number		UL ② Listing	Const. Ref.	Watt Rating/ Class of Coil Insulation ③
			Min.	Max.			Air-Inert Gas	Water/Light Oil			
				Low Vacuum (Hg) ①	Air/Gas/ Water/Oil						
Brass Body											
1/4	3/64	.06	0	29	230	150	SD8202G001V	SD8202G051V	●	1	22.6/F
1/4	3/32	.14	0	29	115	150	SD8202G002V	SD8202G052V	●	1	22.6/F
1/4	1/8	.28	0	29	60	150	SD8202G003V	SD8202G053V	●	1	22.6/F
1/4	5/32	.50	0	29	35	150	SD8202G004V	SD8202G054V	●	1	22.6/F
1/4	7/32	.85	0	29	20	150	SD8202G006V	SD8202G056V	●	1	22.6/F
1/4	9/32	1.1	0	29	15	150	SD8202G007V	SD8202G057V	●	1	22.6/F
3/8	1/8	.28	0	29	60	150	SD8202G023V	SD8202G073V	●	2	22.6/F
3/8	5/32	.50	0	29	35	150	SD8202G024V	SD8202G074V	●	2	22.6/F
3/8	7/32	.85	0	29	20	150	SD8202G026V	SD8202G076V	●	2	22.6/F
3/8	9/32	1.1	0	29	15	150	SD8202G027V	SD8202G077V	●	2	22.6/F
Stainless Steel Body											
1/4	3/64	.06	0	29	230	150	SD8202G011V	SD8202G061V	●	3	22.6/F
1/4	3/32	.14	0	29	115	150	SD8202G012V	SD8202G062V	●	3	22.6/F
1/4	1/8	.28	0	29	60	150	SD8202G013V	SD8202G063V	●	3	22.6/F
1/4	5/32	.50	0	29	35	150	SD8202G014V	SD8202G064V	●	3	22.6/F
1/4	7/32	.85	0	29	20	150	SD8202G016V	SD8202G066V	●	3	22.6/F
1/4	9/32	1.1	0	29	15	150	SD8202G017V	SD8202G067V	●	3	22.6/F
3/8	1/8	.28	0	29	60	150	SD8202G033V	SD8202G083V	●	4	22.6/F
3/8	5/32	.50	0	29	35	150	SD8202G034V	SD8202G084V	●	4	22.6/F
3/8	7/32	.85	0	29	20	150	SD8202G036V	SD8202G086V	●	4	22.6/F
3/8	9/32	1.1	0	29	15	150	SD8202G037V	SD8202G087V	●	4	22.6/F

① Applicable to air-Inert gas valves only.
 ② ● General Purpose valve. Refer to Engineering Section (Approvals) for more details.
 ③ Will vary with duty cycle (8.5 watts at 500 mA with ambient temp. = 104°F (40°C)).

SPECIAL SERVICE VALVES

Pipe Size (in)	Orifice Size (in)	Cv Flow Factor	Operating Pressure Differential (psi)			Max. Fluid Temp. °F	Catalog Number		UL ② Listing	Const. Ref.	Watt Rating/ Class of Coil Insulation ③
			Min.	Max.			Water/Light Oil				
				Water/ Light Oil							
Brass Body											
3/8	1/2	2.4	5	150	150	SD8203G001	-	5	22.6/F		
1/2	1/2	2.4	5	150	150	SD8203G002	-	5	22.6/F		

Specifications (Metric units)

Pipe Size (in)	Orifice Size (mm)	Kv Flow Factor (m ³ /h)	Operating Pressure Differential (bar)			Max. Fluid Temp. °C	Catalog Number		UL ② Listing	Const. Ref.	Watt Rating/ Class of Coil Insulation ③
			Min.	Max.			Air-Inert Gas	Water/Light Oil			
				Low Vacuum (Hg) ①	Air/Gas/ Water/Oil						
Brass Body											
1/4	1.2	.05	0	2	16	65	SD8202G001V	SD8202G051V	●	1	22.6/F
1/4	2.4	.12	0	2	8	65	SD8202G002V	SD8202G052V	●	1	22.6/F
1/4	3.2	.24	0	2	4	65	SD8202G003V	SD8202G053V	●	1	22.6/F
1/4	4.0	.42	0	2	2	65	SD8202G004V	SD8202G054V	●	1	22.6/F
1/4	5.6	.72	0	2	1	65	SD8202G006V	SD8202G056V	●	1	22.6/F
1/4	7.1	.90	0	2	1	65	SD8202G007V	SD8202G057V	●	1	22.6/F
3/8	3.2	.24	0	2	4	65	SD8202G023V	SD8202G073V	●	2	22.6/F
3/8	4.0	.42	0	2	2	65	SD8202G024V	SD8202G074V	●	2	22.6/F
3/8	5.6	.72	0	2	1	65	SD8202G026V	SD8202G076V	●	2	22.6/F
3/8	7.1	.90	0	2	1	65	SD8202G027V	SD8202G077V	●	2	22.6/F
Stainless Steel Body											
1/4	1.2	.05	0	2	16	65	SD8202G011V	SD8202G061V	●	3	22.6/F
1/4	2.4	.12	0	2	8	65	SD8202G012V	SD8202G062V	●	3	22.6/F
1/4	3.2	.24	0	2	4	65	SD8202G013V	SD8202G063V	●	3	22.6/F
1/4	4.0	.42	0	2	2	65	SD8202G014V	SD8202G064V	●	3	22.6/F
1/4	5.6	.72	0	2	1	65	SD8202G016V	SD8202G066V	●	3	22.6/F
1/4	7.1	.90	0	2	1	65	SD8202G017V	SD8202G067V	●	3	22.6/F
3/8	3.2	.24	0	2	4	65	SD8202G033V	SD8202G083V	●	4	22.6/F
3/8	4.0	.42	0	2	2	65	SD8202G034V	SD8202G084V	●	4	22.6/F
3/8	5.6	.72	0	2	1	65	SD8202G036V	SD8202G086V	●	4	22.6/F
3/8	7.1	.90	0	2	1	65	SD8202G037V	SD8202G087V	●	4	22.6/F

① Applicable to air-Inert gas valves only.
 ② ● General Purpose valve. Refer to Engineering Section (Approvals) for more details.
 ③ Will vary with duty cycle (8.5 watts at 500 mA with ambient temp. = 104°F (40°C)).

Pipe Size (in)	Orifice Size (mm)	Kv Flow Factor (m ³ /h)	Operating Pressure Differential (bar)		Max. Fluid Temp. °C	Catalog Number		UL ② Listing	Const. Ref.	Watt Rating/ Class of Coil Insulation ③
			Min.	Max.		Water/Light Oil	Water/Light Oil			
				Water/Light Oil						
Brass Body										
3/8	12.7	2.1	.3	10	65	SD8203G001	-	5	22.6/F	
1/2	12.7	2.1	.3	10	65	SD8203G002	-	5	22.6/F	

SPECIAL SERVICE VALVES

Dimensions inches (mm)

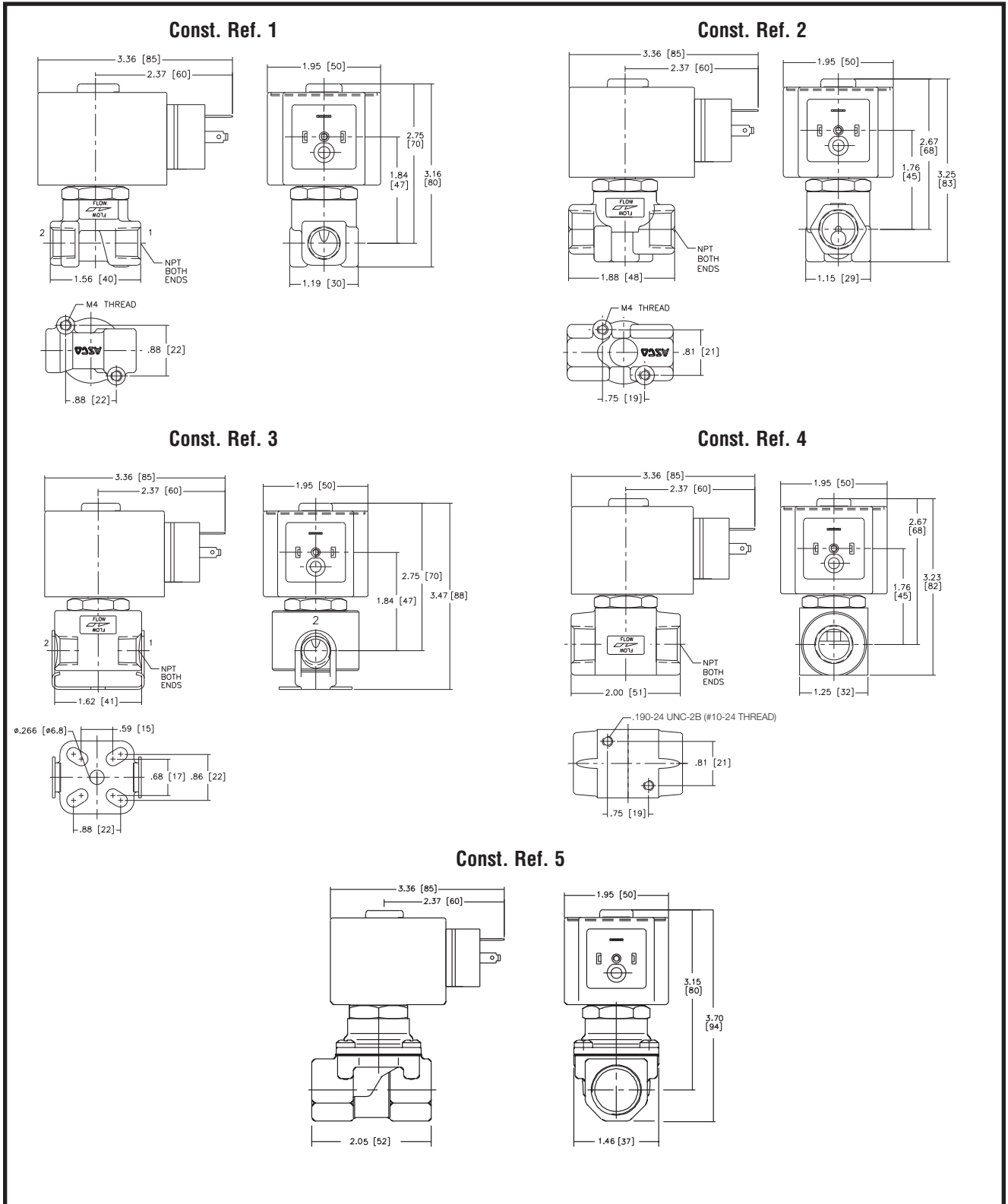

SPECIAL SERVICE VALVES

Description

One unit, Catalog Number 8908A001, can be used for all 1/4" to 1/2" Posiflow valves with DIN solenoids.

To maintain a specific flow rate, current through the coil must be kept constant and substantially independent from changes in the coil winding resistance (caused by temperature variation). The Electronic Control Unit will accomplish this quite efficiently via pulse width modulation. Voltage to the coil is cut into rectangular pulses by rapidly switching it on and off. By varying the "on" time (pulse width) percentage to compensate for temperature variations, current through the coil is kept constant.

Electrical Characteristics

Nominal supply voltage:

24 VDC \pm 10%, maximum ripple 10%

Maximum full-load current:

1100 mA (factory set at 500 mA)

Input control signal (selectable):

0-10 VDC or 0-20 mA or 4-20 mA

Switch-off current:

<2% of max. input control signal

Adjustable off-set:

15-50% of pulse width modulation voltage

Adjustable full-load:

30-100% of pulse width modulation voltage

Ramp time:

Manually activated via on/off switch; adjustable 0.1-3 seconds

Adjustable PWM frequency:

40-700 Hz

Power consumption:

0.8 watts

Construction

Housing Assembly	PA + FV
Cover	PA + FV
Screw	Zinc plated steel
Gasket	NBR
Connector Specification	ISO 4400/DIN 43650
Protection	IP 65 (Dust-tight Protection against water jets from any direction)

Dimensions inches (mm)

Catalog No.	A	B	C	D	E	F	G	H
8908A001	2.76 (70)	1.89 (48)	1.18 (30)	1.61 (41)	1.18 (30)	0.16 (4)	1.26 (32)	2.03 (51.5)

