



Air Preparation Products Stainless Steel Products

PF504 Particulate Filters	F2-F3
PF10 Particulate Filters	F4-F5
PF501 Coalescing Filters	F6-F7
PF11 Coalescing Filters	F8-F9
PR354 & PR364 Regulators	F10-F11
PR10 & PR11 Regulators	F12-F13
PB548 & PB558 Filter / Regulators	F14-F15
PB11 & PB12 Filter / Regulators	F16-F17
PL10 Lubricators	F18-F19



Stainless Steel
Products

PF504 Particulate Filters – Miniature

- Stainless steel construction handles most corrosive environments
- Fluorocarbon seals standard
- Meets NACE specifications MR-01-75/ISO 15156
- 1/8" female threaded drain
- 1/4" port (NPT, BSPP)

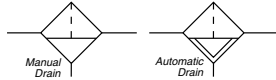

Port size	Description	Part number
1/4"	Twist drain, NPT	PF504-02DHSS
1/4"	Auto pulse drain, NPT	PF504-02DHRSS

Operating information

Operating pressure:	
Twist drain	0 to 300 psig (0 to 20.7 bar)
Auto pulse drain	10 to 175 psig (0 to 12 bar)
Operating temperature:	
Twist drain	0°F to 180°F (-18°C to 82°C)
Auto pulse drain	32°F to 150°F (0°C to 66°C)
Flow capacity†:	23 scfm (10.9 dm ³ /s, ANR)
Bowl capacity:	1.0 oz.
Filter rating:	20 micron
Sump capacity:	0.4 oz.
Weight:	0.6 lb (0.27 kg)

Note: Air must be dry enough to avoid ice formation at temperatures below 32°F (0°C)

† scfm = Standard cubic feet per minute at 90 psig inlet and 5 psig pressure drop.

Ordering information:

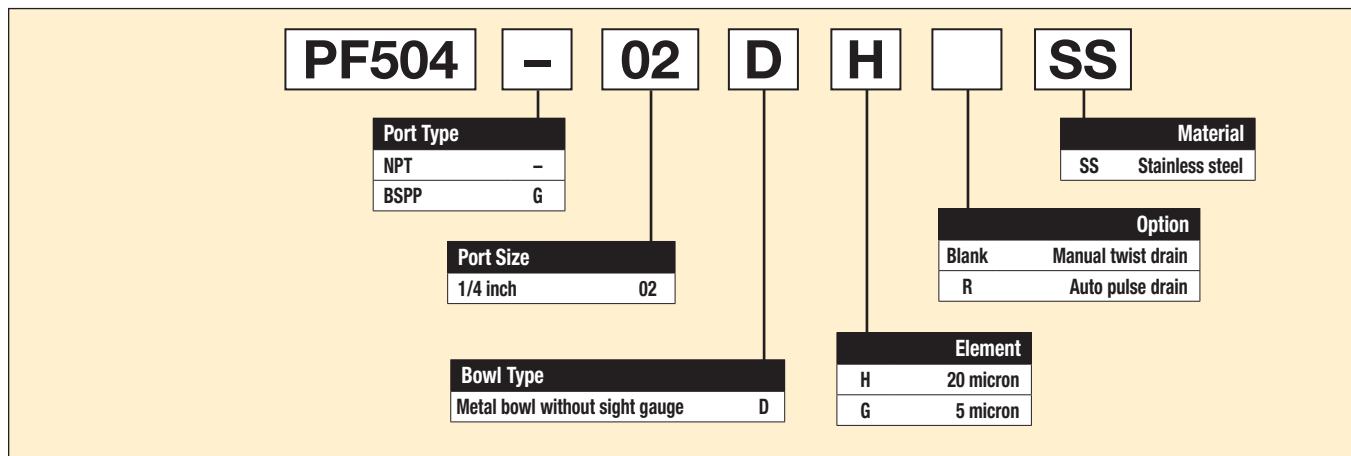

Most popular.



For inventory, lead times, and kit lookup, visit www.pdnplu.com

Stainless Steel Products
Filters
Coalescers
Regulators
Filter / Regulators
Lubricators

Miniature Particulate Filter

Operation

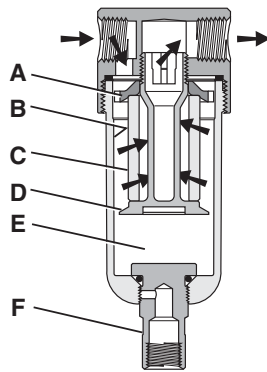

First Stage Filtration:

Air enters at inlet port and flows through deflector plate (A) which causes a swirling action. Liquids and coarse particles are forced to the bowl interior wall (B) by the centrifugal action of the swirling air. They are then carried down the bowl wall by the force of gravity. The baffle (D) separates the lower portion of the bowl into a "quiet zone" (E) where the removed liquid and particles collect, unaffected by the swirling air, and are therefore not reentrained into the flowing air.

Second Stage Filtration:

After liquids and large particles are removed in the first stages of filtration, the air flows through element (C) where smaller particles are filtered out. The filtered air then passes downstream. Collected liquids and particles in the "quiet zone" (E) should be drained before their level reaches a height where they would be reentrained in the flowing air. This can be accomplished by unscrewing the drain valve (F) slightly until the liquid begins to drain.

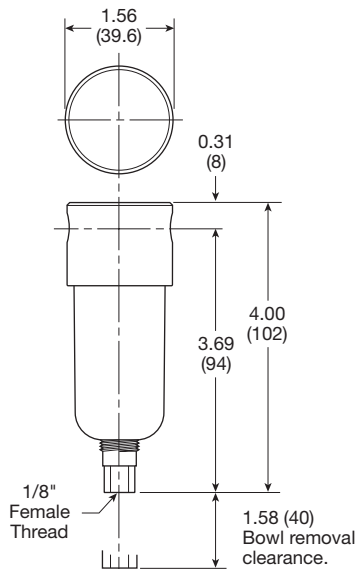

Inches (mm)

Air Preparation Products Stainless Steel

Material Specifications

Body	316 stainless steel
Bowls	316 stainless steel
Deflector	Acetal
Drain	316 stainless steel
Element holder	Acetal
Filter element	Polyethylene
Seals	Fluorocarbon

Repair and Service Kits

Auto pulse drain	RK504SY-SS
Manual twist drain (small, old)	SA600Y7-1SS
Manual twist drain (large, new)	SAP05481
5 micron element	EK504VY
20 micron element	EK504Y
Pipe nipple, 1/4" 316 stainless steel	1/4 FF-SS

Flow Charts

PF504 1/4" Filter

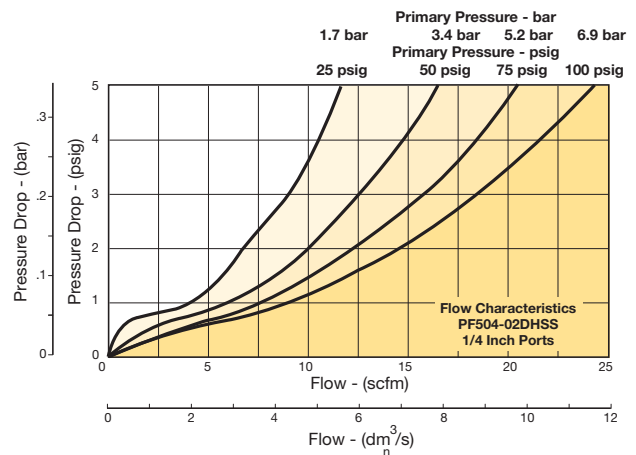

Stainless Steel
Products

Filters

Coalescers

Regulators

Filter /
Regulators

Lubricators



For inventory, lead time, and kit lookup, visit www.pdnplu.com

PF10 Particulate Filters – Standard

- Stainless steel construction handles most corrosive environments
- Fluorocarbon seals standard
- Meets NACE specifications MR-01-75/ISO 15156
- 1/8" female threaded drain
- 1/2" port (NPT, BSPP)

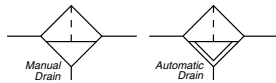

Port size	Description	Part number
1/2"	Twist drain, with sight gauge, NPT	PF10-04WJSS
1/2"	Auto float drain, with sight gauge, NPT	PF10-04WJRSS

Operating information

Operating pressure:	
Twist drain, no sight gauge	0 to 300 psig (0 to 20.7 bar)
Twist drain, sight gauge	0 to 250 psig (0 to 17.2 bar)
Auto float drain	10 to 175 psig (0 to 12 bar)
Operating temperature:	
Twist drain, no sight gauge	0°F to 180°F (-18°C to 82°C)
Twist drain, sight gauge	0°F to 150°F (-18°C to 66°C)
Auto float drain	32°F to 150°F (0°C to 66°C)
Flow capacity†:	70 scfm (33 dm ³ /s, ANR)
Bowl capacity:	4.0 oz.
Filter rating:	40 micron
Sump capacity:	1.7 oz.
Weight:	1.9 lb (0.85 kg)

Note: Air must be dry enough to avoid ice formation at temperatures below 32°F (0°C)

† scfm = Standard cubic feet per minute at 90 psig inlet and 5 psig pressure drop.

Ordering information:

PF10 - 04 D J SS

Port Type		Material
NPT	-	SS Stainless steel
BSPP	G	
Port Size		Option
1/2 inch	04	Blank Manual twist drain
		R Auto float drain
Bowl Type		Element
Metal bowl without sight gauge	D	J 40 micron
Metal bowl with sight gauge	W	G 5 micron

Most popular.



For inventory, lead times, and kit lookup, visit www.pdnplu.com

Stainless Steel Products
Filters
Coalescers
Regulators
Filter / Regulators
Lubricators

Standard Particulate Filter

Operation

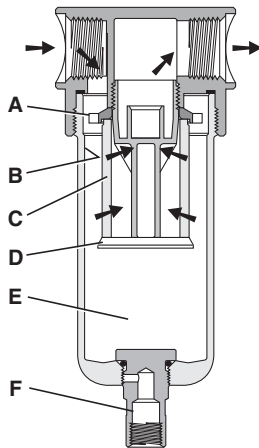

First Stage Filtration:

Air enters at inlet port and flows through deflector plate (A) which causes a swirling action. Liquids and coarse particles are forced to the bowl interior wall (B) by the centrifugal action of the swirling air. They are then carried down the bowl wall by the force of gravity. The baffle (D) separates the lower portion of the bowl into a "quiet zone" (E) where the removed liquid and particles collect, unaffected by the swirling air, and are therefore not reentrained into the flowing air.

Second Stage Filtration:

After liquids and large particles are removed in the first stages of filtration, the air flows through element (C) where smaller particles are filtered out. The filtered air then passes downstream. Collected liquids and particles in the "quiet zone" (E) should be drained before their level reaches a height where they would be reentrained in the flowing air. This can be accomplished by unscrewing the drain valve (F) slightly until the liquid begins to drain.

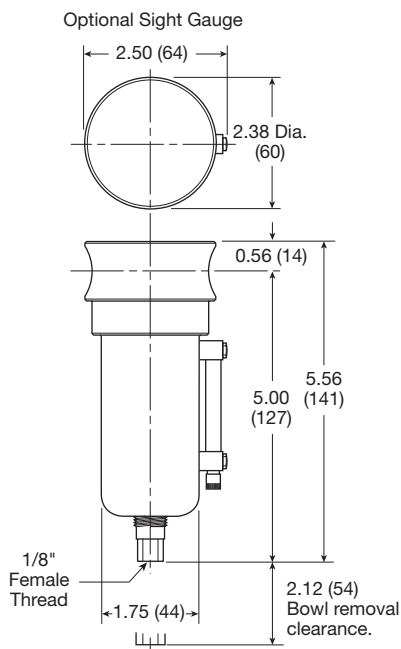

Inches (mm)

Air Preparation Products Stainless Steel

Material Specifications

Body	316 stainless steel
Bowls	316 stainless steel
Deflector	Acetal
Drain	316 stainless steel
Element holder	Acetal
Filter element	Polyethylene
Seals	Fluorocarbon
Sight gauge	Isoplast

Repair and Service Kits

Automatic float drain	SA10MDSS
Manual twist drain (small, old)	SA600Y7-1SS
Manual twist drain (large, new)	SAP05481
40 micron element	EK55J
5 micron element	EK55G
Pipe nipple, 1/2" 316 stainless steel	616A28-SS

Flow Charts

PF10 1/2" Filter

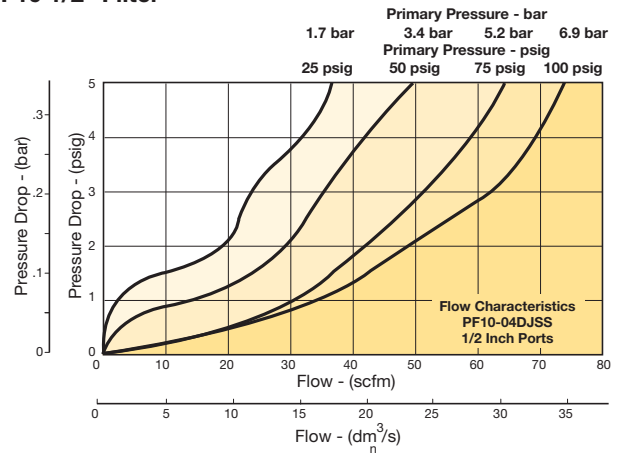

Stainless Steel
Products

Filters

Coalescers

Regulators

Filter /
Regulators

Lubricators



For inventory, lead time, and kit lookup, visit www.pdnplu.com

PF501 Coalescing Filters – Miniature

- Stainless steel construction handles most corrosive environments
- Meets NACE specifications MR-01-75/ISO 15156
- 1/8" female threaded drain
- 1/4" port (NPT, BSPP)

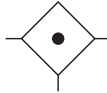

Port size	Description	Part number
1/4"	Twist drain, NPT	PF501-02DHSS
1/4"	Auto pulse drain, NPT	PF501-02DHRSS

Operating information

Operating pressure:
 Twist drain 0 to 300 psig (0 to 20.7 bar)
 Auto pulse drain 10 to 175 psig (0 to 12 bar)

Operating temperature:
 Twist drain 0°F to 180°F (-18°C to 82°C)
 Auto pulse drain 32°F to 150°F (0°C to 66°C)

Flow capacity†: 16 scfm (7.6 dm³/s, ANR)
 Bowl capacity: 1.0 oz.
 Filter rating: 0.01 micron
 Sump capacity: 0.4 oz.
 Weight: 0.6 lb (0.27 kg)

Note: Air must be dry enough to avoid ice formation at temperatures below 32°F (0°C)

† scfm = Standard cubic feet per minute at 90 psig inlet and 5 psig pressure drop.

Ordering information:

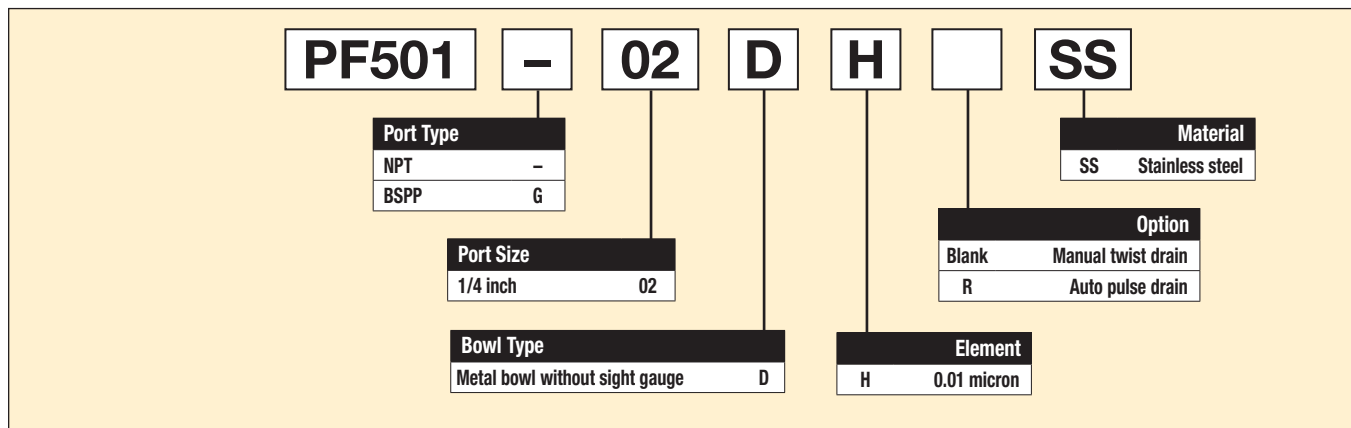

Stainless Steel Products
 Filters
 Coalescers
 Regulators
 Filter / Regulators
 Lubricators



For inventory, lead times, and kit lookup, visit www.pdnplu.com

Miniature Coalescing Filter

Operation

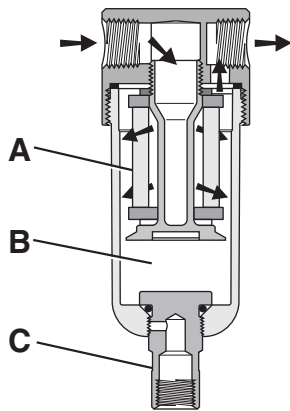

The contaminated air enters the element interior and is forced through a thick membrane (A) of "borosilicate" glass fibers coated with epoxy. Flow then passes through the element, and at this stage 99.97% of the sub-micronic particles have been removed from the air stream. The tiny droplets coalesce together and are collected from the filter element by the outer drain layer.

The clean, filtered air now passes through and out into the pneumatic system. The air line coalescing filter removes liquid aerosols and sub-micron particulate matter.

Collected liquids and particles in the "quiet zone" (B) should be drained before their level reaches a height where they would be reentrained in the flowing air. This can be accomplished by unscrewing the drain valve (C) slightly until the liquid begins to drain.

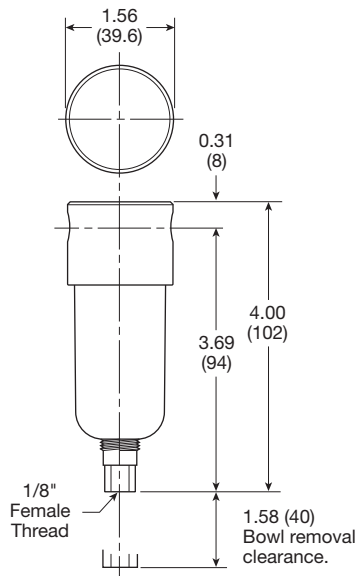

Inches (mm)

Air Preparation Products Stainless Steel

Material Specifications

Body	316 stainless steel
Bowls	316 stainless steel
Drain	316 stainless steel
Element holder	Acetal
Filter element	Borosilicate Fiber
Seals	Fluorocarbon

Repair and Service Kits

Auto pulse drain	RK504SY-SS
Manual twist drain (small, old)	SA600Y7-1SS
Manual twist drain (large, new)	SAP05481
0.01 micron element	EKF501H
Pipe nipple, 1/4" 316 stainless steel	1/4 FF-SS

Flow Charts

PF501 1/4" Coalescing Filter

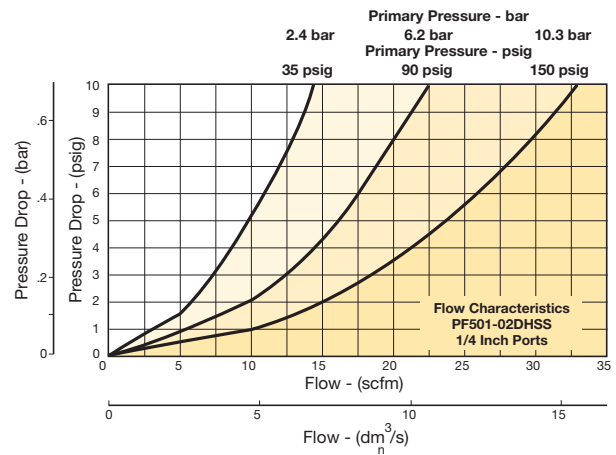

Stainless Steel
Products

Filters

Coalescers

Regulators

Filter /
Regulators

Lubricators



For inventory, lead time, and kit lookup, visit www.pdnplu.com

PF11 Coalescing Filters – Standard

- Stainless steel construction handles most corrosive environments
- Meets NACE specifications MR-01-75/ISO 15156
- 1/8" female threaded drain
- 1/2" port (NPT, BSPP)

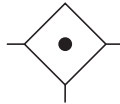

Port size	Description	Part number
1/2"	Twist drain, with sight gauge, NPT	PF11-04WJSS
1/2"	Auto float drain, with sight gauge, NPT	PF11-04WJRSS

Operating information

Operating pressure:
 Twist drain, no sight gauge 0 to 300 psig (0 to 20.7 bar)
 Twist drain, sight gauge 0 to 250 psig (0 to 17.2 bar)
 Auto float drain 10 to 175 psig (0 to 12 bar)

Operating temperature:
 Twist drain, no sight gauge 0°F to 180°F (-18°C to 82°C)
 Twist drain, sight gauge 0°F to 150°F (-18°C to 66°C)
 Auto float drain 32°F to 150°F (0°C to 66°C)

Flow capacity†: 45 scfm (21.2 dm³/s, ANR)

Bowl capacity: 4.0 oz.

Filter rating: 0.01 micron

Sump capacity: 1.7 oz.

Weight: 1.9 lb (0.85 kg)

Note: Air must be dry enough to avoid ice formation at temperatures below 32°F (0°C)

† scfm = Standard cubic feet per minute at 90 psig inlet and 5 psig pressure drop.

Ordering information:

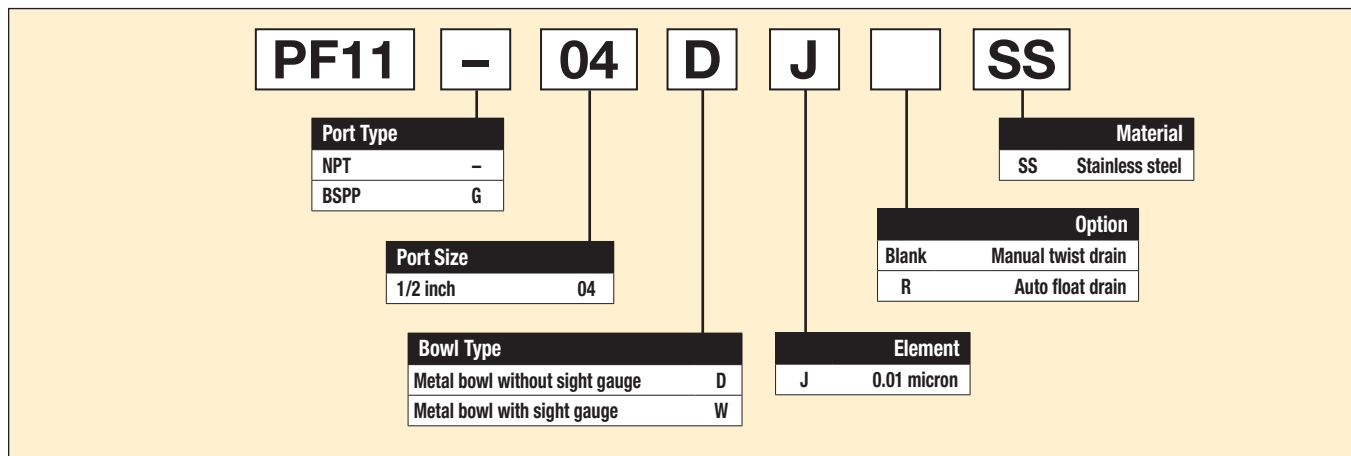

Most popular.



For inventory, lead times, and kit lookup, visit www.pdnplu.com

Stainless Steel Products
 Filters
 Coalescers
 Regulators
 Filter / Regulators
 Lubricators

Standard Coalescing Filter

Operation

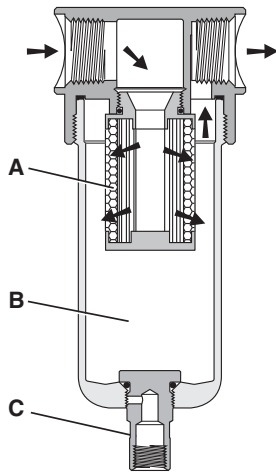

The contaminated air enters the element interior and is forced through a thick membrane (A) of "borosilicate" glass fibers coated with epoxy. Flow then passes through the element, and at this stage 99.9997% of the sub-micronic particles have been removed from the air stream. The tiny droplets coalesce together and are collected from the filter element by the outer drain layer.

The clean, filtered air now passes through and out into the pneumatic system. The air line coalescing filter removes liquid aerosols and sub-micron particulate matter.

Collected liquids and particles in the "quiet zone" (B) should be drained before their level reaches a height where they would be reentrained in the flowing air. This can be accomplished by unscrewing the drain valve (C) slightly until the liquid begins to drain.

Optional Sight Gauge

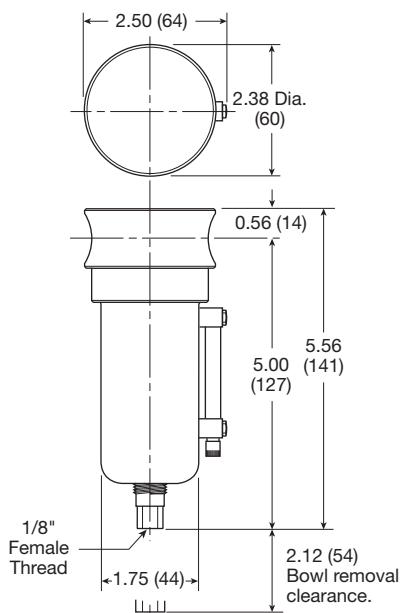

Inches (mm)

Air Preparation Products Stainless Steel

Material Specifications

Body	316 Stainless Steel
Bowls	316 Stainless Steel
Drain	316 Stainless Steel
Element holder	Acetal
Filter element	Borosilicate Fiber
Seals	Fluorocarbon
Sight gauge	Isoplast

Repair and Service Kits

Automatic float drain	SA10MDSS
0.01 micron element	EKF71
Pipe nipple, 1/2" 316 stainless steel	616A28-SS

Flow Charts

PF11 1/2" Coalescing Filter

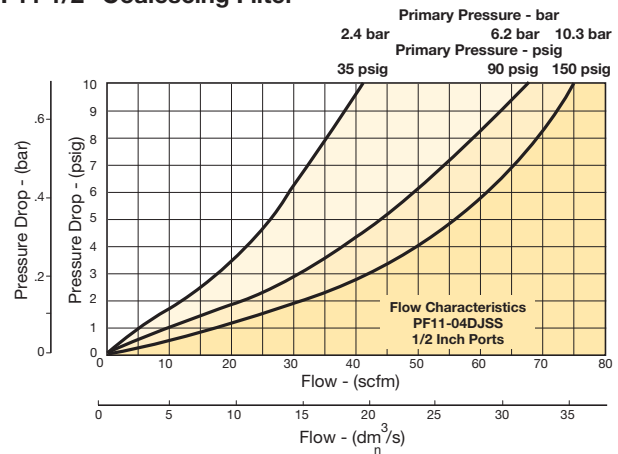

Stainless Steel
Products

Filters

Coalescers

Regulators

Filter /
Regulators

Lubricators



For inventory, lead time, and kit lookup, visit www.pdnplu.com

PR354, PR364 Regulator – Miniature

- Stainless steel construction handles most corrosive environments
- Large diaphragm to valve area ratio for precise regulation and high flow capacity
- Meets NACE specifications MR-01-75/ISO 15156
- 1/4" port (NPT, BSPP)



PR364



PR354

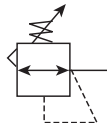

Port size	Description	Part number
1/4"	Standard knob, NPT	PR364-02CSS
1/4"	Stainless steel, NPT	PR354-02CSS

Operating information

Operating pressure:	
PR354	300 psig (20.7 bar)
PR364	300 psig (20.7 bar)
Operating temperature:	
PR354	0°F to 180°F (-18°C to 82°C)
PR364	0°F to 150°F (-18°C to 66°C)
Flow capacity†:	12 scfm (5.7 dm ³ /s, ANR)
Gauge port:	1/4 inch
Operation:	Fluorocarbon diaphragm
Weight:	0.5 lb (0.23 kg)

Note: Air must be dry enough to avoid ice formation at temperatures below 32°F (0°C)

† scfm = Standard cubic feet per minute at 100 psig inlet, 75 psig no flow secondary setting and 15 psig pressure drop.

Ordering information:

PR364 - 02 C SS

Series	Material
Stainless steel PR354	SS Stainless steel
Standard knob PR364	

Port Type	Options
NPT -	Blank Relieving
BSPP G	K Non-relieving
	P Panel mount nut

Port Size	Pressure Range
1/4 inch 02	A 0 to 25 psig (0 to 1.7 bar)
	B 0 to 60 psig (0 to 4.1 bar)
	C 0 to 125 psig (0 to 8.5 bar)

Most popular.



For inventory, lead times, and kit lookup, visit www.pdnplu.com

Stainless Steel Products
Filters
Coalescers
Regulators
Filter / Regulators
Lubricators

Miniature Regulators

Operation

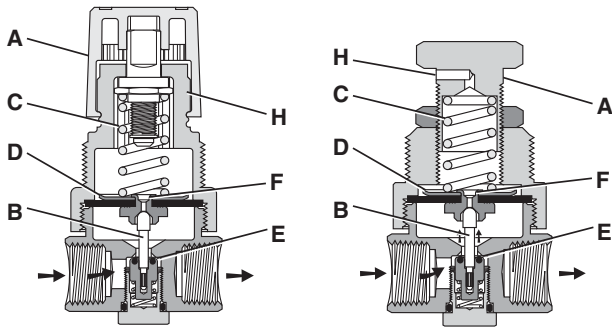

With the adjusting knob (A) turned fully counter-clockwise (no spring load), and pressure supplied to the regulator inlet port, the valve poppet assembly (B) is closed. Turning the adjusting knob clockwise applies a load to control spring (C). This load causes the diaphragm (D) and the valve poppet assembly (B) to move downward allowing flow across the seat area (E) created between the poppet assembly and the seat. Pressure in the downstream line is sensed below the diaphragm (D) and offsets the load of spring (C). As downstream pressure rises, poppet assembly (B) and diaphragm (D) move upward until the area (E) is closed and the load of the spring (C) and pressure under diaphragm (D) are in balance. A reduced outlet pressure has now been obtained, depending on spring load. Creating a demand downstream, such as opening a valve, results in a reduced pressure under the diaphragm (D). The load of control spring (C) now causes the poppet assembly to move downward opening seat area (E) allowing air to flow to meet the downstream demand. The flow of downstream air is metered by the amount of opening (E).

Should downstream pressure exceed the desired regulated pressure, the excess pressure will cause the diaphragm (D) to move upward against control spring (C), open vent hole (F), and vent the excess pressure to atmosphere through the hole in the bonnet (H). (This occurs in the relieving type regulator only.)

PR354

PR364

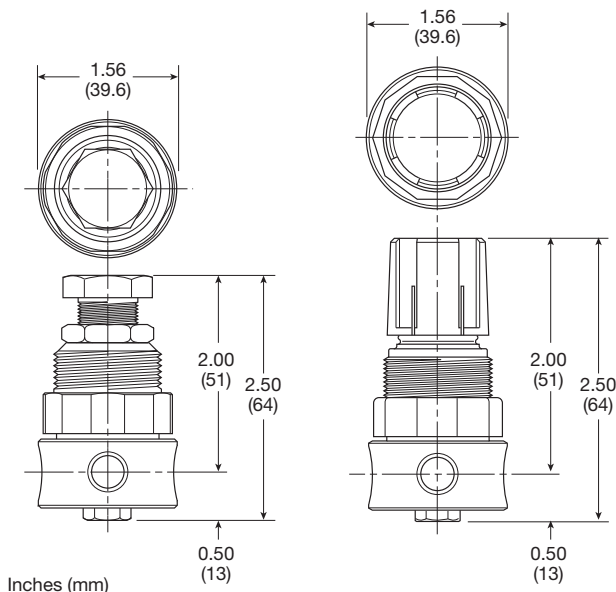

Air Preparation Products Stainless Steel

Material Specifications

Adjustment mechanism / springs	316 stainless steel
Adjusting knob (PR354)	316 Stainless Steel
Adjusting knob (PR364)	Polypropylene
Body	316 stainless steel
Bonnet (PR354)	316 stainless steel
Bonnet (PR364)	Acetal
Bottom plug	316 stainless steel
Poppet	316 stainless steel
Seals	Fluorocarbon

Repair and Service Kits

PR354 bonnet kit	CKR354YSS
PR364 bonnet kit (knob included)	CKR364Y-1SS
1-1/2" face, 160 psig (0 to 1100 kPa), gauge (stainless)	K4515N14160SS
Panel mount bracket (Stainless)	161X57-SS
Panel mount nut, stainless	R05X51-SS
Panel mount nut, plastic	R05X51-P
Pipe nipple, 1/4" 316 stainless steel	1/4 FF-SS
Relieving	RKR364YSS
Non-relieving	RKR364KYSS
0-25 psig spring	SPR-375-2-SS
0-60 psig spring	SPR-376-1-SS
0-125 psig spring	SPR-377-1-SS

Flow Charts

PR354, PR364 1/4" Regulator

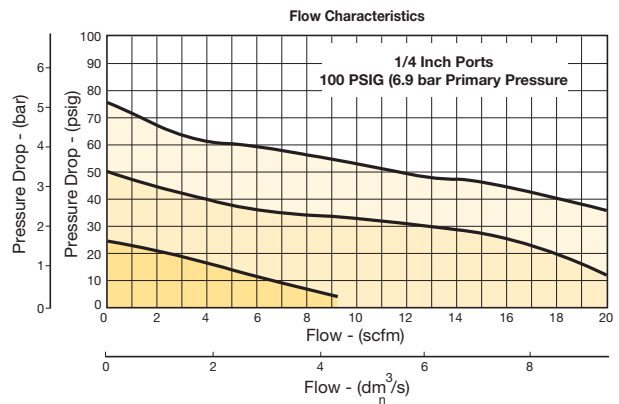

⚠ WARNING

**Product rupture can cause serious injury.
Do not connect regulator to bottled gas.
Do not exceed Maximum primary pressure rating.**

CAUTION:

REGULATOR PRESSURE ADJUSTMENT – The working range of knob adjustment is designed to permit outlet pressures within their full range. Pressure adjustment beyond this range is also possible because the knob is not a limiting device. This is a common characteristic of most industrial regulators, and limiting devices may be obtained only by special design. For best performance, regulated pressure should always be set by increasing the pressure up to the desired setting.



For inventory, lead time, and kit lookup, visit www.pdnplu.com



Stainless Steel
Products

Filters

Coalescers

Regulators

Filter /
Regulators

Lubricators

PR10, PR11 Regulator – Standard

- Stainless steel construction handles most corrosive environments
- Large diaphragm to valve area ratio for precise regulation and high flow capacity
- Meets NACE specifications MR-01-75/ISO 15156
- Low temperature version available
- 1/2" port (NPT, BSPP)

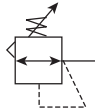

PR11



PR10

Port size	Description	Part number
1/2"	Standard knob, NPT	PR10-04CSS
1/2"	Stainless steel T-handle, NPT	PR11-04CSS

Operating information

Operating pressure:	
PR10	300 psig (20.7 bar)
PR11	300 psig (20.7 bar)
Operating temperature:	
PR10	0°F to 150°F (-18°C to 66°C)
PR11	0°F to 180°F (-18°C to 82°C)
	Option "L" minimum -40°F (-40°C)
Flow capacity†:	80 scfm (37.8 dm ³ /s, ANR)
Gauge port:	1/4 inch
Operation:	Fluorocarbon diaphragm
Weight:	1.79 lb (0.81 kg)

Note: Air must be dry enough to avoid ice formation at temperatures below 32°F (0°C)

† scfm = Standard cubic feet per minute at 100 psig inlet, 75 psig no flow secondary setting and 15 psig pressure drop.

Ordering information:

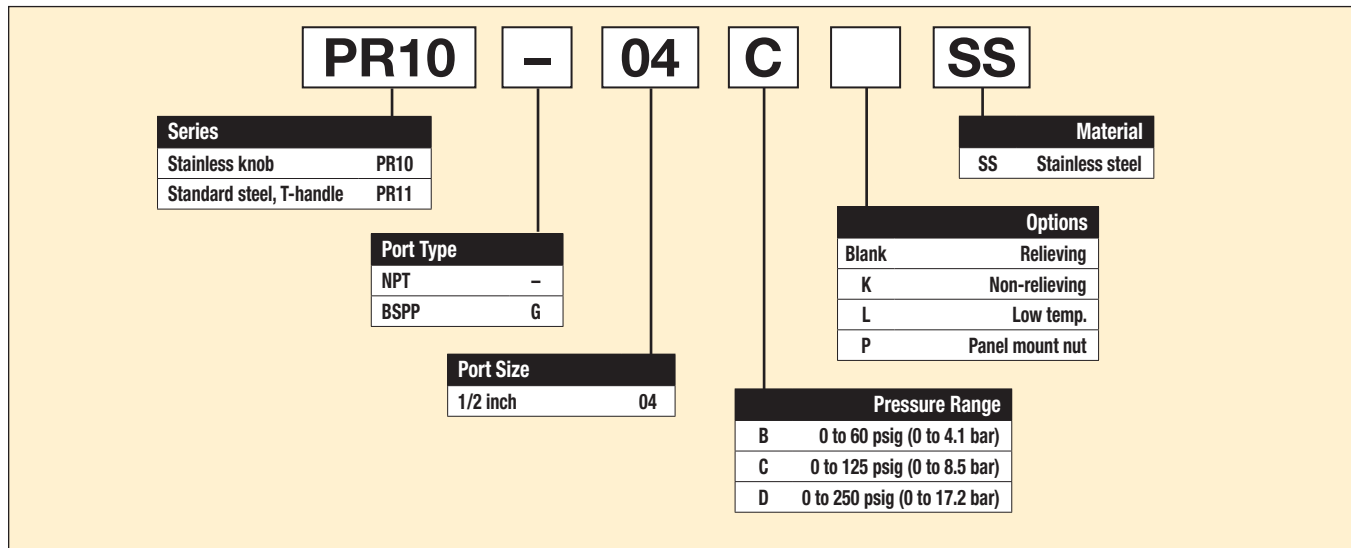

Most popular.



For inventory, lead times, and kit lookup, visit www.pdnplu.com

Stainless Steel Products
 Filters
 Coalescers
 Regulators
 Filter / Regulators
 Lubricators

Operation

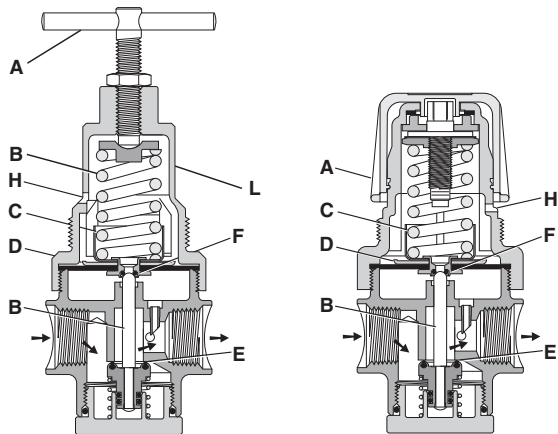

With the adjusting knob / T-Handle (A) turned fully counter-clockwise (no spring load), and pressure supplied to the regulator inlet port, the valve poppet assembly (B) is closed. Turning the adjusting knob clockwise applies a load to control spring (C). This load causes the diaphragm (D) and the valve poppet assembly (B) to move downward allowing flow across the seat area (E) created between the poppet assembly and the seat. Pressure in the downstream line is sensed below the diaphragm (D) and offsets the load of spring (C). As downstream pressure rises, poppet assembly (B) and diaphragm (D) move upward until the area (E) is closed and the load of the spring (C) and pressure under diaphragm (D) are in balance. A reduced outlet pressure has now been obtained, depending on spring load. Creating a demand downstream, such as opening a valve, results in a reduced pressure under the diaphragm (D). The load of control spring (C) now causes the poppet assembly to move downward opening seat area (E) allowing air to flow to meet the downstream demand. The flow of downstream air is metered by the amount of opening (E).

Should downstream pressure exceed the desired regulated pressure, the excess pressure will cause the diaphragm (D) to move upward against control spring (C), open vent hole (F), and vent the excess pressure to atmosphere through the hole in the bonnet (H). (This occurs in the relieving type regulator only.)

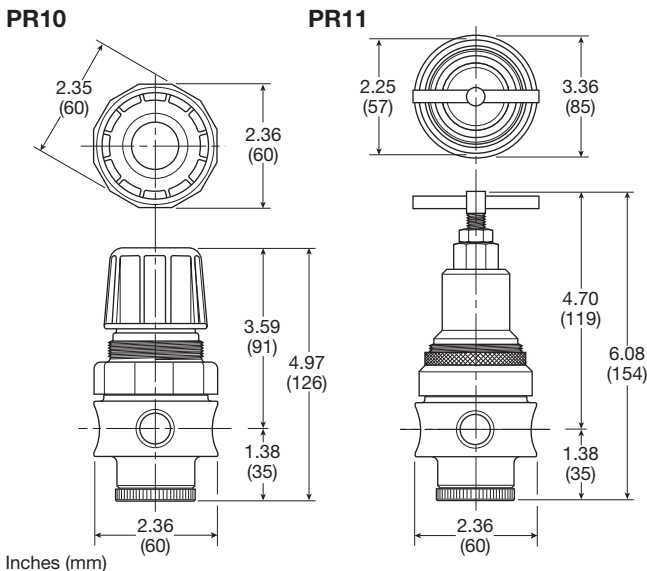

Material Specifications

Adjustment mechanism / springs	316 stainless steel
Body	316 stainless steel
Bonnet / tee handle (PR11)	316 stainless steel
Bonnet / knob (PR10)	Acetal
Bottom plug	316 stainless steel
Poppet	316 stainless steel
Seals	Fluorocarbon

Repair and Service Kits

PR10 bonnet kit (knob included)	CKR10YSS
PR11 bonnet kit	CKR11YSS
2" Face 160 psig (0 to 1100 kPa), gauge (stainless)	K4520N14160SS
Panel mount bracket (stainless)	R10Y57-SS
Panel mount nut, stainless	R10X51-SS
Panel mount nut, plastic	R10X51-P
Pipe nipple, 1/2" 316 stainless steel	616A28-SS
Relieving	RKR10YSS
Non-relieving	RKR10KYSS
0-60 psig spring	SPR-388-1-SS
0-125 psig spring	SPR-389-1-SS
0-250 psig spring	SPR-390-1-SS

Flow Charts

PR10 1/2" Regulator

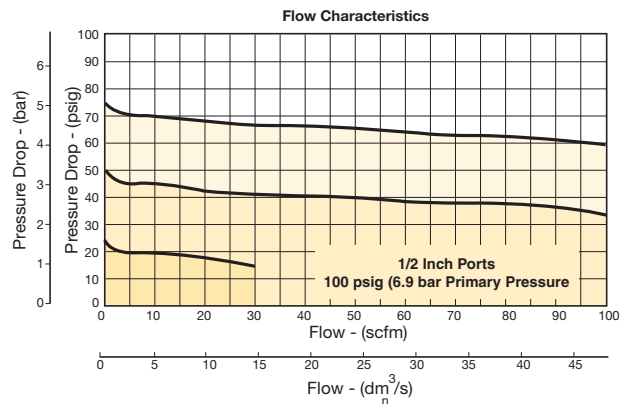

WARNING
 Product rupture can cause serious injury.
 Do not connect regulator to bottled gas.
 Do not exceed Maximum primary pressure rating.

CAUTION:

REGULATOR PRESSURE ADJUSTMENT – The working range of knob adjustment is designed to permit outlet pressures within their full range. Pressure adjustment beyond this range is also possible because the knob is not a limiting device. This is a common characteristic of most industrial regulators, and limiting devices may be obtained only by special design. For best performance, regulated pressure should always be set by increasing the pressure up to the desired setting.



For inventory, lead time, and kit lookup, visit www.pdnplu.com

PB548, PB558 Filter / Regulator – Miniature

- Stainless steel construction handles most corrosive environments
- Large diaphragm to valve area ratio for precise regulation and high flow capacity
- 1/8" female threaded drain
- Meets NACE specifications MR-01-75/ISO 15156
- 1/4" port (NPT, BSPP)

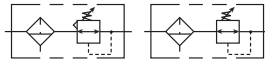

PB548

PB558

Port size	Description	Part number
1/4"	Standard knob, NPT	PB548-02DHCSS
1/4"	Stainless steel, NPT	PB558-02DHCSS

Operating information

Operating pressure:
 PB548 300 psig (20.7 bar)
 PB558 300 psig (20.7 bar)
 Auto pulse drain 10 to 175 psig (0 to 12 bar)

Operating temperature:
 PB548 0°F to 150°F (-18°C to 66°C)
 PB558 0°F to 180°F (-18°C to 82°C)
 Auto pulse drain 32°F to 150°F (0°C to 66°C)

Flow capacity†: 12 scfm (5.7 dm³/s, ANR)
 Bowl capacity: 1.0 oz.
 Filter rating: 20 micron
 Sump capacity: 0.4 oz.
 Gauge port: 1/4 inch
 Operation: Fluorocarbon diaphragm
 Weight: 0.6 lb (0.27 kg)

Note: Air must be dry enough to avoid ice formation at temperatures below 32°F (0°C)

† scfm = Standard cubic feet per minute at 100 psig inlet, 75 psig no flow secondary setting and 15 psig pressure drop.

Ordering information:

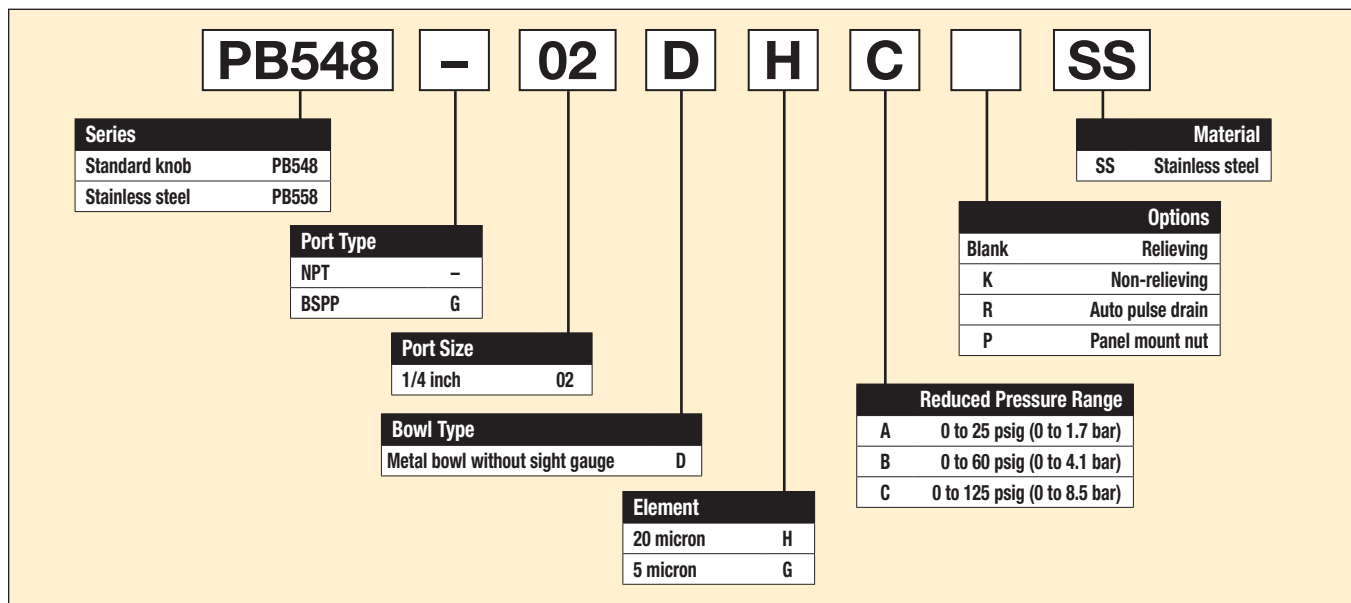

Most popular.



For inventory, lead times, and kit lookup, visit www.pdnplu.com

Stainless Steel Products
 Filters
 Coalescers
 Regulators
 Filter / Regulators
 Lubricators

Miniature Filter / Regulator

Operation

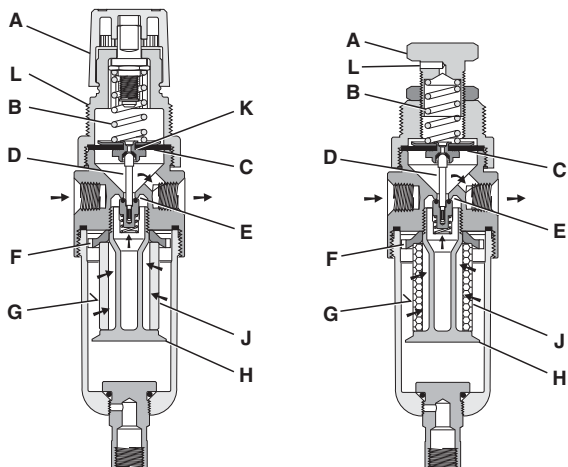

Turning the adjusting knob (A) clockwise applies a load to control spring (B) which forces diaphragm (C) and valve poppet assembly (D) to move downward allowing filtered air to flow through the seat area (E) created between the poppet assembly and the seat. "First stage filtration". Air pressure supplied to the inlet port is directed through deflector plate (F) causing a swirling centrifugal action forcing liquids and coarse particles to the inner bowl wall (G) and down below the lower baffle (H) to the quiet zone. After liquids and large particles are removed in the first stage of filtration "second stage filtration" occurs as air flows through element (J) where smaller particles are filtered out and retained. The air flow now passes through seat area (E) to the outlet port of the unit. Pressure in the downstream line is sensed below the diaphragm (C) and offsets the load of spring (B). When downstream pressure reaches the set-point, poppet valve assembly (D) and diaphragm (C) move upward closing seat area (E). Should downstream pressure exceed the desired regulated pressure, the excess pressure will cause the diaphragm (C) to move upward opening vent hole (K) venting the excess pressure to atmosphere through the hole in the bonnet (L). (This occurs in the standard relieving type filter/regulators only.)

PB548

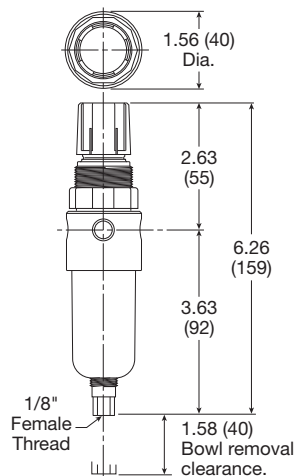

Inches (mm)

PB558

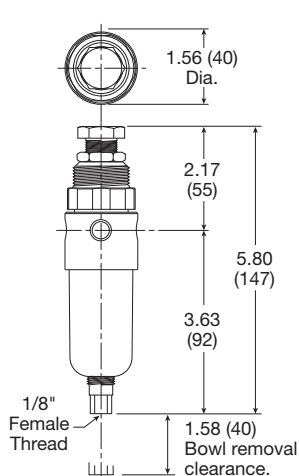

Air Preparation Products Stainless Steel

Material Specifications

Adjustment mechanism / springs	316 stainless steel
Body	316 Stainless steel
Bonnet (PB548)	Acetal
Bonnet (PB558)	316 stainless steel
Bottom plug	316 stainless steel
Knob (PB548)	Polypropylene
Knob (PB558)	316 stainless steel
Poppet	316 stainless steel
Seals	Fluorocarbon

Repair and Service Kits

PB558 bonnet kit (knob included)	CKR354YSS
PB548 bonnet kit (knob included)	CKR364Y-1SS
Automatic pulse drain	RK504SY-SS
Manual twist drain (small, old)	SA600Y7-1SS
Manual twist drain (large, new)	SAP05481
5 micron element	EK504VY
20 micron element	EK504Y
1-1/2" face 160 psig (0 to 1100 kPa), gauge (stainless)	K4515N14160SS
Panel mount bracket (stainless)	161X57-SS
Panel mount nut, stainless	R05X51-SS
Panel mount nut, plastic	R05X51-P
Pipe nipple, 1/4" 316 stainless steel	1/4 FF-SS
Relieving	RK549YSS
Non-relieving	RK548YSS
0-25 psig spring	SPR-375-2-SS
0-60 psig spring	SPR-376-1-SS
0-125 psig spring	SPR-377-1-SS

Flow Charts

PB548, PB558 1/4" Filter / Regulator

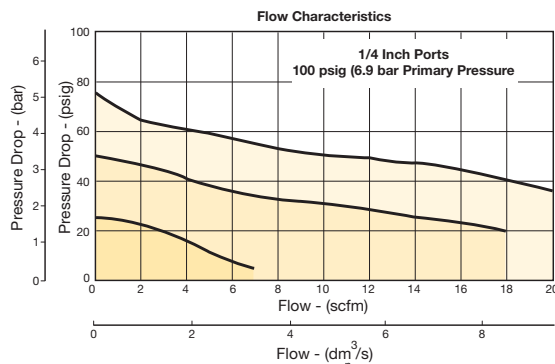

⚠ WARNING

**Product rupture can cause serious injury.
Do not connect regulator to bottled gas.
Do not exceed Maximum primary pressure rating.**

CAUTION:

REGULATOR PRESSURE ADJUSTMENT – The working range of knob adjustment is designed to permit outlet pressures within their full range. Pressure adjustment beyond this range is also possible because the knob is not a limiting device. This is a common characteristic of most industrial regulators, and limiting devices may be obtained only by special design. For best performance, regulated pressure should always be set by increasing the pressure up to the desired setting.



For inventory, lead time, and kit lookup, visit www.pdnplu.com

P

Stainless Steel Products

Filters

Coalescers

Regulators

Filter / Regulators

Lubricators

PB11, PB12 Filter / Regulator – Standard

- Stainless steel construction handles most corrosive environments
- Large diaphragm to valve area ratio for precise regulation and high flow capacity
- 1/8" female threaded drain
- Meets NACE specifications MR-01-75/ISO-15156
- Low temperature version available
- 1/2" port (NPT, BSPP)



PB11

PB12

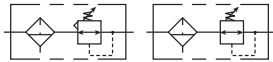

Port size	Description	Part number
With sight gauge, NPT		
1/2"	Standard knob, twist drain	PB11-04WJCSS
1/2"	Standard knob, auto float drain	PB11-04WJCRSS
1/2"	Stainless steel T-handle, twist drain	PB12-04WJCSS
1/2"	Stainless steel T-handle, auto float drain	PB12-04WJCRSS

Operating information

Operating pressure:	
PB11, PB12	300 psig (20.7 bar)
Auto float drain	15 to 175 psig (1 to 12 bar)
Operating temperature:	
PB11	0°F to 150°F (-18°C to 66°C)
PB12, no sight gauge	0°F to 180°F (-18°C to 82°C)
PB12, sight gauge	0°F to 150°F (-18°C to 66°C)
Auto float drain	32°F to 150°F (0°C to 66°C)
Flow capacity†:	72 scfm (34 dm³/s, ANR)
Bowl capacity:	4.0 oz.
Filter rating:	40 micron
Sump capacity:	1.7 oz.
Gauge port:	1/4 inch
Operation:	Fluorocarbon diaphragm
Weight:	2.42 lb (1.09 kg)

Note: Air must be dry enough to avoid ice formation at temperatures below 32°F (0°C)

† scfm = Standard cubic feet per minute at 100 psig inlet, 75 psig no flow secondary setting and 15 psig pressure drop.

Ordering information:

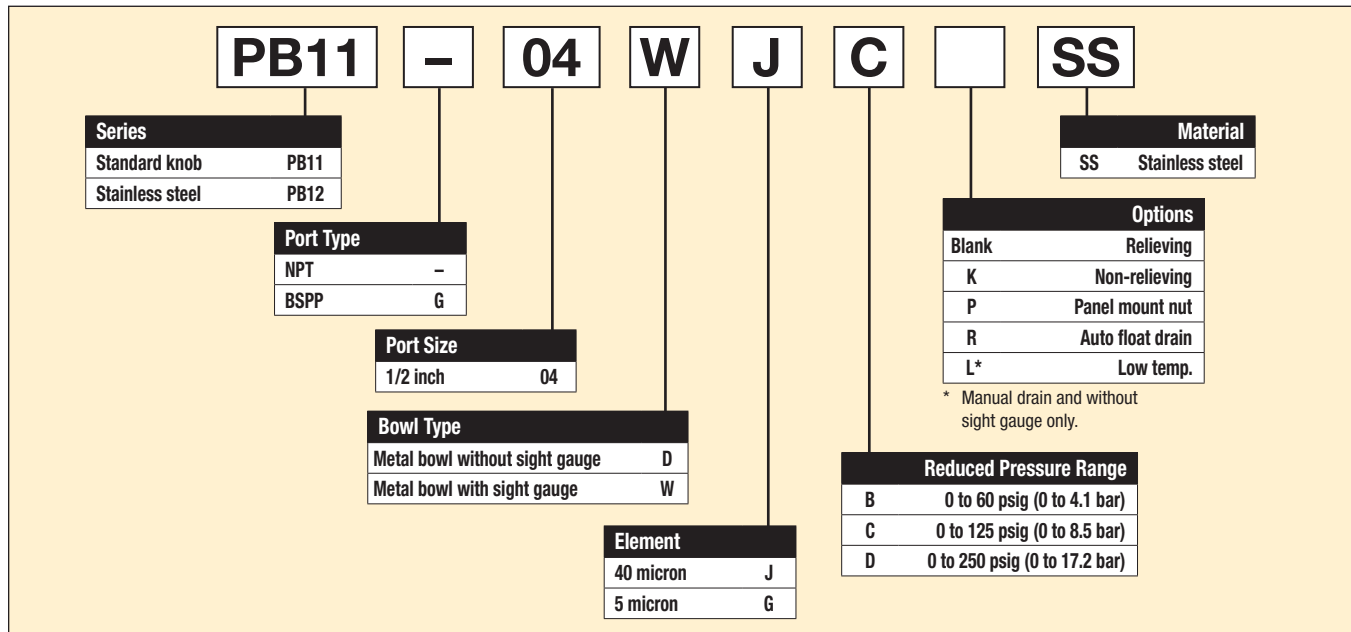

Most popular.



For inventory, lead times, and kit lookup, visit www.pdnplu.com

Stainless Steel
 Filters
 Coalescers
 Regulators
 Filter / Regulators
 Lubricators

Standard Filter / Regulator

Operation

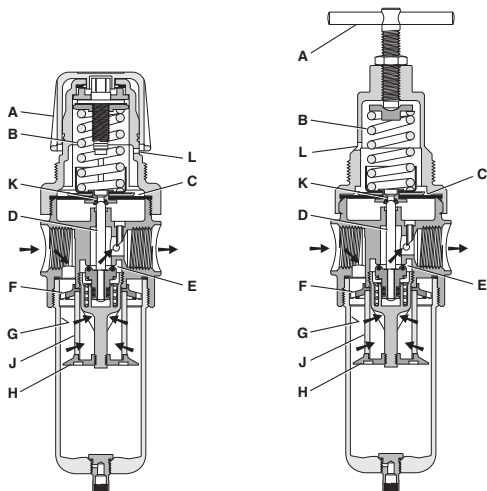

Turning the adjusting knob / T-Handle (A) clockwise applies a load to control spring (B) which forces diaphragm (C) and valve poppet assembly (D) to move downward allowing filtered air to flow through the seat area (E) created between the poppet assembly and the seat. "First stage filtration". Air pressure supplied to the inlet port is directed through deflector plate (F) causing a swirling centrifugal action forcing liquids and coarse particles to the inner bowl wall (G) and down below the lower baffle (H) to the quiet zone. After liquids and large particles are removed in the first stage of filtration "second stage filtration" occurs as air flows through element (J) where smaller particles are filtered out and retained. The air flow now passes through seat area (E) to the outlet port of the unit. Pressure in the downstream line is sensed below the diaphragm (C) and offsets the load of spring (B). When downstream pressure reaches the set-point, poppet valve assembly (D) and diaphragm (C) move upward closing seat area (E). Should downstream pressure exceed the desired regulated pressure, the excess pressure will cause the diaphragm (C) to move upward opening vent hole (K) venting the excess pressure to atmosphere through the hole in the bonnet (L). (This occurs in the standard relieving type filter/regulators only.)

PB11

Inches (mm)

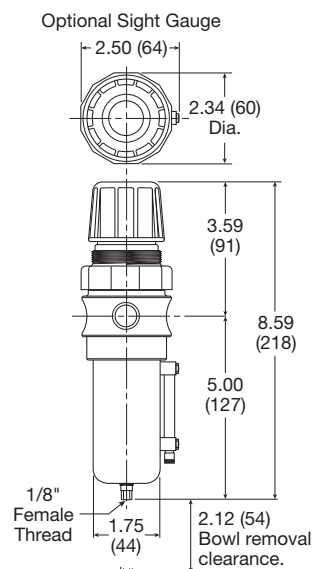

PB12

Optional Sight Gauge

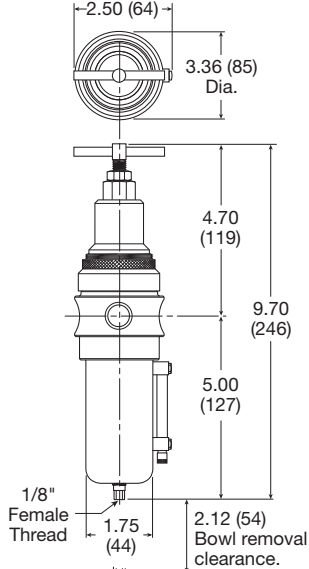

Air Preparation Products Stainless Steel

Material Specifications

Adjustment mechanism / springs	316 stainless steel
Body	316 stainless steel
Bonnet / knob (PB11)	Acetal
Bonnet / tee handle (PB12)	316 stainless steel
Bottom plug	316 stainless steel
Poppet	316 stainless steel
Seals	Fluorocarbon
Sight gauge	Isoplast

Repair and Service Kits

PB11 bonnet kit (knob included)	CKR10YSS
PB12 bonnet kit	CKR11YSS
Auto float drain	SA10MDSS
Manual twist drain (small, old)	SA600Y7-1SS
Manual twist drain (large, new)	SAP05481
40 micron element	EKF10Y
5 micron element	EKF10VY
2" face 160 psig (0 to 1100 kPa), gauge (stainless)	K4520N14160SS
Panel mount bracket (stainless)	R10Y57-SS
Panel mount nut, stainless	R10X51-SS
Panel mount nut, plastic	R10X51-P
Pipe nipple, 1/2" 316 stainless steel	616A28-SS
Relieving	RKR10YSS
Non-relieving	RKR10KYSS
0-60 psig spring	SPR-388-1-SS
0-125 psig spring	SPR-389-1-SS
0-250 psig spring	SPR-390-1-SS

Flow Charts

PB11 1/2" Filter / Regulator

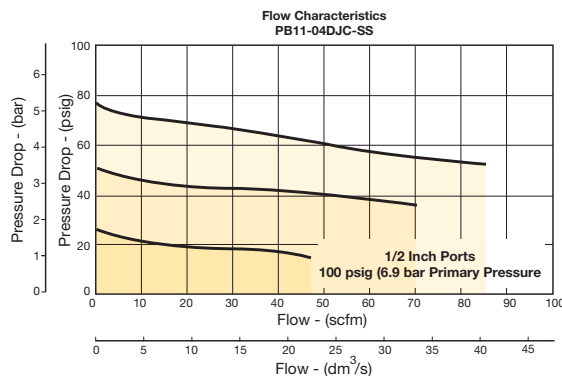

⚠ WARNING

**Product rupture can cause serious injury.
Do not connect regulator to bottled gas.
Do not exceed Maximum primary pressure rating.**

CAUTION:

REGULATOR PRESSURE ADJUSTMENT – The working range of knob adjustment is designed to permit outlet pressures within their full range. Pressure adjustment beyond this range is also possible because the knob is not a limiting device. This is a common characteristic of most industrial regulators, and limiting devices may be obtained only by special design. For best performance, regulated pressure should always be set by increasing the pressure up to the desired setting.



For inventory, lead time, and kit lookup, visit www.pdnpnu.com

P

Stainless Steel Products

Filters

Coalescers

Regulators

Filter / Regulators

Lubricators

PL10 Lubricators – Standard

- Stainless steel construction handles most corrosive environments
- 1/8" female threaded drain
- Fillable under pressure
- Meets NACE specifications MR-01-75/ISO 15156
- 1/2" port (NPT, BSPP)



Port size	Description	Part number
1/2"	Twist drain, with sight gauge, NPT	PL10-04WSS
1/2"	Twist drain, without sight gauge, NPT	PL10-04DSS

Operating information

Operating pressure:	
Metal bowl, no sight gauge	0 to 300 psig (0 to 20.7 bar)
Metal bowl, sight gauge	0 to 250 psig (0 to 17.2 bar)
Operating temperature:	
Metal bowl, no sight gauge	0°F to 150°F (-18°C to 66°C)
Metal bowl, sight gauge	0°F to 150°F (-18°C to 66°C)
Flow capacity†:	100 scfm (47.2 dm ³ /s, ANR)
Bowl capacity:	4.0 oz.
Weight:	1.9 lb (0.85 kg)

Note: Air must be dry enough to avoid ice formation at temperatures below 32°F (0°C)

† scfm = Standard cubic feet per minute at 90 psig inlet and 5 psig pressure drop.

Ordering information:

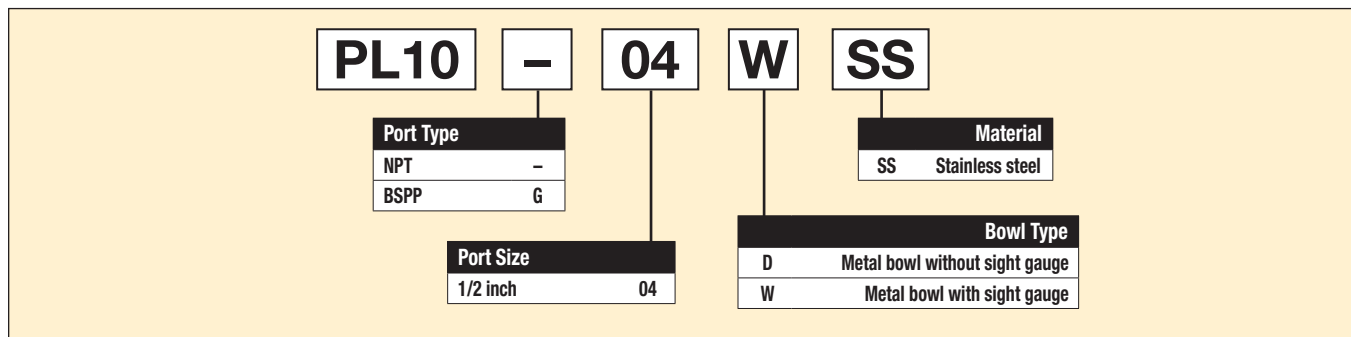

Most popular.



For inventory, lead times, and kit lookup, visit www.pdnplu.com

Stainless Steel Products
 Filters
 Coalescers
 Regulators
 Filter / Regulators
 Lubricators

Standard Lubricator

Operation

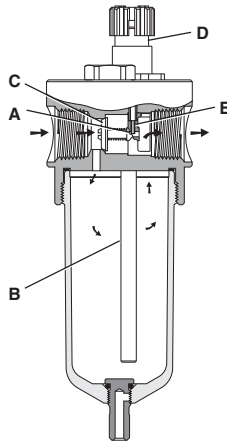

Air flowing through the unit goes through two paths. At low flow rates the majority of the air flows through the Venturi section (A). The rest of the air opens the check valve (C). The velocity of the air flowing through the Venturi section (A) creates a pressure drop. This lower pressure allows the oil to be forced from the reservoir through the pickup tube (B) and travels up to the metering screw (D). The rate of oil delivery is then controlled by adjusting the metering screw (D). Oil flows past the metering screw (D) and forms a drop in the nozzle tube (E). As the oil drops through the dome (F) and back into the Venturi section (A), it is broken up into fine particles. It is then mixed with the air flowing past the check valve (C) and is carried downstream. As the air flow increases the check valve (C) will open more fully. This additional flow will assure that the oil delivery rate will increase linearly with the increase of air flow.

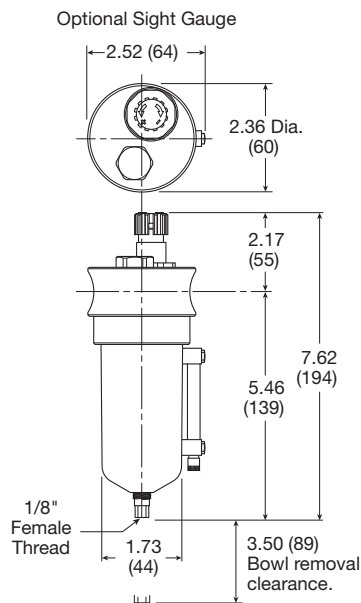

Inches (mm)

Air Preparation Products Stainless Steel

Material Specifications

Body	316 stainless steel
Bowl	316 stainless steel
Dip tube	316 stainless steel
Drain	316 stainless steel
Fill plug	316 stainless steel
Seals	Fluorocarbon
Sight dome	Nylon
Sight gauge	Isoplast

Repair and Service Kits

Manual twist drain (small, old)	SA600Y7-1SS
Manual twist drain (large, new)	SAP05481
Pipe nipple, 1/2" 316 stainless steel	616A28-SS
Sight dome kit, (old)	RKL10SS
Sight dome kit, (new)	PS740N

Flow Charts

PL10 1/2" Lubricator

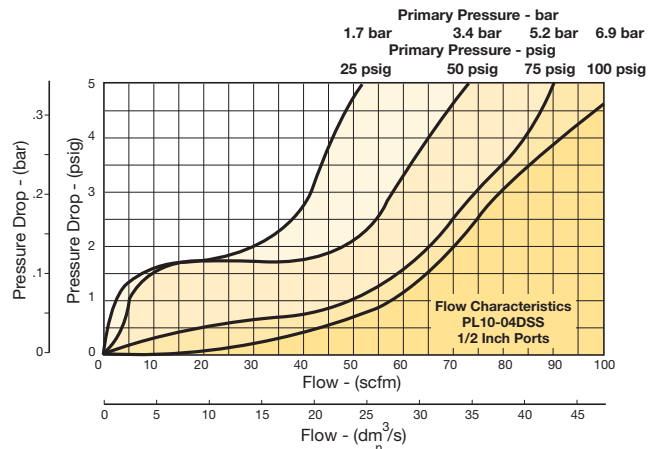

For inventory, lead time, and kit lookup, visit www.pdnplu.com

Safety Guide For Selecting And Using Pneumatic Division Products And Related Accessories

WARNING:

FAILURE OR IMPROPER SELECTION OR IMPROPER USE OF PNEUMATIC DIVISION PRODUCTS, ASSEMBLIES OR RELATED ITEMS ("PRODUCTS") CAN CAUSE DEATH, PERSONAL INJURY, AND PROPERTY DAMAGE. POSSIBLE CONSEQUENCES OF FAILURE OR IMPROPER SELECTION OR IMPROPER USE OF THESE PRODUCTS INCLUDE BUT ARE NOT LIMITED TO:

- Unintended or mistimed cycling or motion of machine members or failure to cycle
- Work pieces or component parts being thrown off at high speeds.
- Failure of a device to function properly for example, failure to clamp or unclamp an associated item or device.
- Explosion
- Suddenly moving or falling objects.
- Release of toxic or otherwise injurious liquids or gasses.

Before selecting or using any of these Products, it is important that you read and follow the instructions below.

1. GENERAL INSTRUCTIONS

- 1.1. Scope:** This safety guide is designed to cover general guidelines on the installation, use, and maintenance of Pneumatic Division Valves, FRLs (Filters, Pressure Regulators, and Lubricators), Vacuum products and related accessory components.
- 1.2. Fail-Safe:** Valves, FRLs, Vacuum products and their related components can and do fail without warning for many reasons. Design all systems and equipment in a fail-safe mode, so that failure of associated valves, FRLs or Vacuum products will not endanger persons or property.
- 1.3 Relevant International Standards:** For a good guide to the application of a broad spectrum of pneumatic fluid power devices see: ISO 4414:1998, Pneumatic Fluid Power – General Rules Relating to Systems. See www.iso.org for ordering information.
- 1.4. Distribution:** Provide a copy of this safety guide to each person that is responsible for selection, installation, or use of Valves, FRLs or Vacuum products. Do not select, or use Parker valves, FRLs or vacuum products without thoroughly reading and understanding this safety guide as well as the specific Parker publications for the products considered or selected.
- 1.5. User Responsibility:** Due to the wide variety of operating conditions and applications for valves, FRLs, and vacuum products Parker and its distributors do not represent or warrant that any particular valve, FRL or vacuum product is suitable for any specific end use system. This safety guide does not analyze all technical parameters that must be considered in selecting a product. The user, through its own analysis and testing, is solely responsible for:
 - Making the final selection of the appropriate valve, FRL, Vacuum component, or accessory.
 - Assuring that all user's performance, endurance, maintenance, safety, and warning requirements are met and that the application presents no health or safety hazards.
 - Complying with all existing warning labels and / or providing all appropriate health and safety warnings on the equipment on which the valves, FRLs or Vacuum products are used; and,
 - Assuring compliance with all applicable government and industry standards.
- 1.6. Safety Devices:** Safety devices should not be removed, or defeated.
- 1.7. Warning Labels:** Warning labels should not be removed, painted over or otherwise obscured.
- 1.8. Additional Questions:** Call the appropriate Parker technical service department if you have any questions or require any additional information. See the Parker publication for the product being considered or used, or call 1-800-CPARKER, or go to www.parker.com, for telephone numbers of the appropriate technical service department.

2. PRODUCT SELECTION INSTRUCTIONS

- 2.1. Flow Rate:** The flow rate requirements of a system are frequently the primary consideration when designing any pneumatic system. System components need to be able to provide adequate flow and pressure for the desired application.
- 2.2. Pressure Rating:** Never exceed the rated pressure of a product. Consult product labeling, Pneumatic Division catalogs or the instruction sheets supplied for maximum pressure ratings.
- 2.3. Temperature Rating:** Never exceed the temperature rating of a product. Excessive heat can shorten the life expectancy of a product and result in complete product failure.
- 2.4. Environment:** Many environmental conditions can affect the integrity and suitability of a product for a given application. Pneumatic Division products are designed for use in general purpose industrial applications. If these products are to be used in unusual circumstances such as direct sunlight and/or corrosive or caustic environments, such use can shorten the useful life and lead to premature failure of a product.
- 2.5. Lubrication and Compressor Carryover:** Some modern synthetic oils can and will attack nitrile seals. If there is any possibility of synthetic oils or greases migrating into the pneumatic components check for compatibility with the seal materials used. Consult the factory or product literature for materials of construction.
- 2.6. Polycarbonate Bowls and Sight Glasses:** To avoid potential polycarbonate bowl failures:
 - Do not locate polycarbonate bowls or sight glasses in areas where they could be subject to direct sunlight, impact blow, or temperatures outside of the rated range.
 - Do not expose or clean polycarbonate bowls with detergents, chlorinated hydro-carbons, ketones, esters or certain alcohols.
 - Do not use polycarbonate bowls or sight glasses in air systems where compressors are lubricated with fire resistant fluids such as phosphate ester and di-ester lubricants.



2.7. Chemical Compatibility: For more information on plastic component chemical compatibility see Pneumatic Division technical bulletins Tec-3, Tec-4, and Tec-5

- 2.8. Product Rupture:** Product rupture can cause death, serious personal injury, and property damage.
- Do not connect pressure regulators or other Pneumatic Division products to bottled gas cylinders.
 - Do not exceed the maximum primary pressure rating of any pressure regulator or any system component.
 - Consult product labeling or product literature for pressure rating limitations.

3. PRODUCT ASSEMBLY AND INSTALLATION INSTRUCTIONS

- 3.1. Component Inspection:** Prior to assembly or installation a careful examination of the valves, FRLs or vacuum products must be performed. All components must be checked for correct style, size, and catalog number. DO NOT use any component that displays any signs of nonconformance.
- 3.2. Installation Instructions:** Parker published Installation Instructions must be followed for installation of Parker valves, FRLs and vacuum components. These instructions are provided with every Parker valve or FRL sold, or by calling 1-800-CPARKER, or at www.parker.com.
- 3.3. Air Supply:** The air supply or control medium supplied to Valves, FRLs and Vacuum components must be moisture-free if ambient temperature can drop below freezing

4. VALVE AND FRL MAINTENANCE AND REPLACEMENT INSTRUCTIONS

4.1. Maintenance: Even with proper selection and installation, valve, FRL and vacuum products service life may be significantly reduced without a continuing maintenance program. The severity of the application, risk potential from a component failure, and experience with any known failures in the application or in similar applications should determine the frequency of inspections and the servicing or replacement of Pneumatic Division products so that products are replaced before any failure occurs. A maintenance program must be established and followed by the user and, at minimum, must include instructions 4.2 through 4.9.

4.2. Installation and Service Instructions: Before attempting to service or replace any worn or damaged parts consult the appropriate Service Bulletin for the valve or FRL in question for the appropriate practices to service the unit in question. These Service and Installation Instructions are provided with every Parker valve and FRL sold, or are available by calling 1-800-CPARKER, or by accessing the Parker web site at www.parker.com.

4.3. Lockout / Tagout Procedures: Be sure to follow all required lockout and tagout procedures when servicing equipment. For more information see: OSHA Standard – 29 CFR, Part 1910.147, Appendix A, The Control of Hazardous Energy – (Lockout / Tagout)

- 4.4. Visual Inspection:** Any of the following conditions requires immediate system shut down and replacement of worn or damaged components:
- Air leakage: Look and listen to see if there are any signs of visual damage to any of the components in the system. Leakage is an indication of worn or damaged components.
 - Damaged or degraded components: Look to see if there are any visible signs of wear or component degradation.
 - Kinked, crushed, or damaged hoses. Kinked hoses can result in restricted air flow and lead to unpredictable system behavior.
 - Any observed improper system or component function: Immediately shut down the system and correct malfunction.
 - Excessive dirt build-up: Dirt and clutter can mask potentially hazardous situations.

Caution: Leak detection solutions should be rinsed off after use.

4.5. Routine Maintenance Issues:

- Remove excessive dirt, grime and clutter from work areas.
- Make sure all required guards and shields are in place.

4.6. Functional Test: Before initiating automatic operation, operate the system manually to make sure all required functions operate properly and safely.

4.7. Service or Replacement Intervals: It is the user’s responsibility to establish appropriate service intervals. Valves, FRLs and vacuum products contain components that age, harden, wear, and otherwise deteriorate over time. Environmental conditions can significantly accelerate this process. Valves, FRLs and vacuum components need to be serviced or replaced on routine intervals. Service intervals need to be established based on:

- Previous performance experiences.
- Government and / or industrial standards.
- When failures could result in unacceptable down time, equipment damage or personal injury risk.

4.8. Servicing or Replacing of any Worn or Damaged Parts: To avoid unpredictable system behavior that can cause death, personal injury and property damage:

- Follow all government, state and local safety and servicing practices prior to service including but not limited to all OSHA Lockout Tagout procedures (OSHA Standard – 29 CFR, Part 1910.147, Appendix A, The Control of Hazardous Energy – Lockout / Tagout).
- Disconnect electrical supply (when necessary) before installation, servicing, or conversion.
- Disconnect air supply and depressurize all air lines connected to system and Pneumatic Division products before installation, service, or conversion.
- Installation, servicing, and / or conversion of these products must be performed by knowledgeable personnel who understand how pneumatic products are to be applied.
- After installation, servicing, or conversions air and electrical supplies (when necessary) should be connected and the product tested for proper function and leakage. If audible leakage is present, or if the product does not operate properly, do not put product or system into use.
- Warnings and specifications on the product should not be covered or painted over. If masking is not possible, contact your local representative for replacement labels.

4.9. Putting Serviced System Back into Operation: Follow the guidelines above and all relevant Installation and Maintenance Instructions supplied with the valve FRL or vacuum component to insure proper function of the system.

Part Number
Index

Safety Guide

Offer of Sale

Part Number Index,
Safety Guide, Offer of Sale



For inventory, lead time, and kit lookup, visit www.pdnplu.com

PARKER-HANNIFIN CORPORATION
OFFER OF SALE

1. **Definitions.** As used herein, the following terms have the meanings indicated.

Buyer:	means any customer receiving a Quote for Products from Seller.
Goods:	means any tangible part, system or component to be supplied by the Seller.
Products:	means the Goods, Services and/or Software as described in a Quote provided by the Seller.
Quote:	means the offer or proposal made by Seller to Buyer for the supply of Products.
Seller:	means Parker-Hannifin Corporation, including all divisions and businesses thereof.
Services:	means any services to be supplied by the Seller.
Software:	means any software related to the Products, whether embedded or separately downloaded.
Terms:	means the terms and conditions of this Offer of Sale or any newer version of the same as published by Seller electronically at www.parker.com/saleterms .

2. **Terms.** All sales of Products by Seller are contingent upon, and will be governed by, these Terms and, these Terms are incorporated into any Quote provided by Seller to any Buyer. Buyer's order for any Products whether communicated to Seller verbally, in writing, by electronic data interface or other electronic commerce, shall constitute acceptance of these Terms. Seller objects to any contrary or additional terms or conditions of Buyer. Reference in Seller's order acknowledgement to Buyer's purchase order or purchase order number shall in no way constitute an acceptance of any of Buyer's terms of purchase. No modification to these Terms will be binding on Seller unless agreed to in writing and signed by an authorized representative of Seller.

3. **Price; Payment.** The Products set forth in Seller's Quote are offered for sale at the prices indicated in Seller's Quote. Unless otherwise specifically stated in Seller's Quote, prices are valid for thirty (30) days and do not include any sales, use, or other taxes or duties. Seller reserves the right to modify prices at any time to adjust for any raw material price fluctuations. Unless otherwise specified by Seller, all prices are F.C.A. Seller's facility (INCOTERMS 2010). All sales are contingent upon credit approval and payment for all purchases is due thirty (30) days from the date of invoice (or such date as may be specified in the Quote). Unpaid invoices beyond the specified payment date incur interest at the rate of 1.5% per month or the maximum allowable rate under applicable law.

4. **Shipment; Delivery; Title and Risk of Loss.** All delivery dates are approximate. Seller is not responsible for damages resulting from any delay. Regardless of the manner of shipment, delivery occurs and title and risk of loss or damage pass to Buyer, upon placement of the Products with the shipment carrier at Seller's facility. Unless otherwise agreed, Seller may exercise its judgment in choosing the carrier and means of delivery. No deferment of shipment at Buyer's request beyond the respective indicated shipping date will be made except on terms that will indemnify, defend and hold Seller harmless against all loss and additional expense. Buyer shall be responsible for any additional shipping charges incurred by Seller due to Buyer's acts or omissions.

5. **Warranty.** The warranty related to the Products is as follows: (i) Goods are warranted against defects in material or workmanship for a period of twelve (12) months from the date of delivery or 2,000 hours of use, whichever occurs first; (ii) Services shall be performed in accordance with generally accepted practices and using the degree of care and skill that is ordinarily exercised and customary in the field to which the Services pertain and are warranted for a period of six (6) months from the completion of the Services by Seller; and (iii) Software is only warranted to perform in accordance with applicable specifications provided by Seller to Buyer for ninety (90) days from the date of delivery or, when downloaded by a Buyer or end-user, from the date of the initial download. All prices are based upon the exclusive limited warranty stated above, and upon the following disclaimer:

DISCLAIMER OF WARRANTY: THIS WARRANTY IS THE SOLE AND ENTIRE WARRANTY PERTAINING TO PRODUCTS. SELLER DISCLAIMS ALL OTHER WARRANTIES, EXPRESS AND IMPLIED, INCLUDING DESIGN, NONINFRINGEMENT, MERCHANTABILITY, AND FITNESS FOR A PARTICULAR PURPOSE. SELLER DOES NOT WARRANT THAT THE SOFTWARE IS ERROR-FREE OR FAULT-TOLERANT, OR THAT BUYER'S USE THEREOF WILL BE SECURE OR UNINTERRUPTED. BUYER AGREES AND ACKNOWLEDGES THAT UNLESS OTHERWISE AUTHORIZED IN WRITING BY SELLER THE SOFTWARE SHALL NOT BE USED IN CONNECTION WITH HAZARDOUS OR HIGH RISK ACTIVITIES OR ENVIRONMENTS. EXCEPT AS EXPRESSLY STATED HEREIN, ALL PRODUCTS ARE PROVIDED "AS IS".

6. **Claims; Commencement of Actions.** Buyer shall promptly inspect all Products upon receipt. No claims for shortages will be allowed unless reported to the Seller within ten (10) days of delivery. Buyer shall notify Seller of any alleged breach of warranty within thirty (30) days after the date the non-conformance is or should have been discovered by Buyer. Any claim or action against Seller based upon breach of contract or any other theory, including tort, negligence, or otherwise must be commenced within twelve (12) months from the date of the alleged breach or other alleged event, without regard to the date of discovery.

7. **LIMITATION OF LIABILITY.** IN THE EVENT OF A BREACH OF WARRANTY, SELLER WILL, AT ITS OPTION, REPAIR OR REPLACE THE NON-CONFORMING PRODUCT, RE-PERFORM THE SERVICES, OR REFUND THE PURCHASE PRICE PAID WITHIN A REASONABLE PERIOD OF TIME. IN NO EVENT IS SELLER LIABLE FOR ANY SPECIAL, INDIRECT, INCIDENTAL OR CONSEQUENTIAL DAMAGES ARISING OUT OF, OR AS THE RESULT OF, THE SALE, DELIVERY, NON-DELIVERY, SERVICING, NON-COMPLETION OF SERVICES, USE, LOSS OF USE OF, OR INABILITY TO USE THE PRODUCTS OR ANY PART THEREOF, LOSS OF DATA, IDENTITY, PRIVACY, OR CONFIDENTIALITY, OR FOR ANY CHARGES OR EXPENSES OF ANY NATURE INCURRED WITHOUT SELLER'S WRITTEN CONSENT, WHETHER BASED IN CONTRACT, TORT OR OTHER LEGAL THEORY. IN NO EVENT SHALL SELLER'S LIABILITY UNDER ANY CLAIM MADE BY BUYER EXCEED THE PURCHASE PRICE PAID FOR THE PRODUCTS.

8. **Loss to Buyer's Property.** Any designs, tools, patterns, materials, drawings, confidential information or equipment furnished by Buyer or any other items which are or become Buyer's property, will be considered obsolete and may be destroyed by Seller after two (2) consecutive years have elapsed without Buyer ordering the Products manufactured using such property. Seller shall not be responsible for any loss or damage to such property while it is in Seller's possession or control.

9. **Special Tooling.** Special Tooling includes but is not limited to tooling, jigs, fixtures and associated manufacturing equipment acquired or necessary to manufacture Products. A tooling charge may be imposed for any Special Tooling. Such Special Tooling shall be and remain Seller's property notwithstanding payment of any charges by Buyer. In no event will Buyer acquire any interest in Special Tooling belonging to Seller that is utilized in the manufacture of the Products, even if such Special Tooling has been specially converted or adapted for such manufacture and notwithstanding any charges paid by Buyer. Unless otherwise agreed, Seller has the right to alter, discard or otherwise dispose of any Special Tooling or other property in its sole discretion at any time.

10. **Security Interest.** To secure payment of all sums due, Seller retains a security interest in all Products delivered to Buyer and, Buyer's acceptance of these Terms is deemed to be a Security Agreement under the Uniform Commercial Code. Buyer authorizes Seller as its attorney to execute and file on Buyer's behalf all documents Seller deems necessary to perfect its security interest.

11. **User Responsibility.** The Buyer through its own analysis and testing, is solely responsible for making the final selection of the Products and assuring that all performance, endurance, maintenance, safety and warning requirements of the application of the Products are met. The Buyer must analyze all aspects of the application and follow applicable industry standards, specifications, and other technical information provided with the Product. If Seller provides Product options based upon data or specifications provided by the Buyer, the Buyer is responsible for determining that such data and specifications are suitable and sufficient for all applications and reasonably foreseeable uses of the Products. In the event the Buyer is not the end-user, Buyer will ensure such end-user complies with this paragraph.

12. **Use of Products; Indemnity by Buyer.** Buyer shall comply with all instructions, guides and specifications provided by Seller with the Products. **Unauthorized Uses.** If Buyer uses or resells the Products for any uses prohibited in Seller's instructions, guides or specifications, or Buyer otherwise fails to comply with Seller's instructions, guides and specifications, Buyer acknowledges that any such use, resale, or non-compliance is at Buyer's sole risk. Buyer shall indemnify, defend, and hold Seller harmless from any losses, claims, liabilities, damages, lawsuits, judgments and costs (including attorney fees and defense costs), whether for personal injury, property damage, intellectual property infringement or any other claim, brought by or incurred by Buyer, Buyer's employees, or any other person, arising out of: (a) improper selection, application, design, specification or other misuse of Products provided by Seller; (b) any act or omission, negligent or otherwise, of Buyer; (c) Seller's use of patterns, tooling, equipment, plans, drawings, designs or specifications or other information or things furnished by Buyer; (d) damage to the Products from an external cause, repair or attempted repair by anyone other than Seller, failure to follow instructions, guides and specifications provided by Seller, use with goods not provided by Seller, or opening, modifying, deconstructing or tampering with the Products for any reason; or (e) Buyer's failure to comply with these Terms. Seller shall not indemnify Buyer under any circumstance except as otherwise provided in these Terms.

13. **Cancellations and Changes.** Buyer may not cancel or modify any order for any reason, except with Seller's written consent and upon terms that will indemnify, defend and hold Seller harmless against all direct, incidental and consequential loss or damage. Seller, at any time, may change Product features, specifications, designs and availability.

14. **Limitation on Assignment.** Buyer may not assign its rights or obligations without the prior written consent of Seller.

15. **Force Majeure.** Seller does not assume the risk and is not liable for delay or failure to perform any of Seller's obligations by reason of events or circumstances beyond its reasonable control ("Events of Force Majeure"). Events of Force Majeure shall include without limitation: accidents, strikes or labor disputes, acts of any government or government agency, acts of nature, delays or failures in delivery from carriers or suppliers, shortages of materials, or any other cause beyond Seller's reasonable control.

16. **Waiver and Severability.** Failure to enforce any provision of these Terms will not invalidate that provision; nor will any such failure prejudice Seller's right to enforce that provision in the future. Invalidation of any provision of these Terms by legislation or other rule of law shall not invalidate any other provision herein and, the remaining provisions will remain in full force and effect.

17. **Termination.** Seller may terminate any agreement governed by or arising from these Terms for any reason and at any time by giving Buyer thirty (30) days prior written notice. Seller may immediately terminate, in writing, if Buyer: (a) breaches any provision of these Terms (b) appoints a trustee, receiver or custodian for all or any part of Buyer's property (c) files a petition for relief in bankruptcy on its own behalf, or one filed by a third party (d) makes an assignment for the benefit of creditors; or (e) dissolves its business or liquidates all or a majority of its assets.

18. **Ownership of Software.** Seller retains ownership of all Software supplied to Buyer hereunder. In no event shall Buyer obtain any greater right in and to the Software than a right in the nature of a license limited to the use thereof and subject to compliance with any other terms provided with the Software.

19. **Indemnity for Infringement of Intellectual Property Rights.** Seller is not liable for infringement of any patents, trademarks, copyrights, trade dress, trade secrets or similar rights ("Intellectual Property Rights") except as provided in this Section. Seller will defend at its expense and will pay the cost of any settlement or damages awarded in an action brought against Buyer based on a third party claim that one or more of the Products sold hereunder infringes the Intellectual Property Rights of a third party in the country of delivery of the Products by the Seller to the Buyer. Seller's obligation to defend and indemnify Buyer is contingent on Buyer notifying Seller within ten (10) days after Buyer becomes aware of any such claim, and Seller having sole control over the defense of the claim including all negotiations for settlement or compromise. If one or more Products sold hereunder is subject to such a claim, Seller may, at its sole expense and option, procure for Buyer the right to continue using the Products, replace or modify the Products so as to render them non-infringing, or offer to accept return of the Products and refund the purchase price less a reasonable allowance for depreciation. Seller has no obligation or liability for any claim of infringement: (i) arising from information provided by Buyer; or (ii) directed to any Products provided hereunder for which the designs are specified in whole or part by Buyer; or (iii) resulting from the modification, combination or use in a system of any Products provided hereunder. The foregoing provisions of this Section constitute Seller's sole and exclusive liability and Buyer's sole and exclusive remedy for such claims of infringement of Intellectual Property Rights.

20. **Governing Law.** These Terms and the sale and delivery of all Products are deemed to have taken place in, and shall be governed and construed in accordance with, the laws of the State of Ohio, as applicable to contracts executed and wholly performed therein and without regard to conflicts of laws principles. Buyer irrevocably agrees and consents to the exclusive jurisdiction and venue of the courts of Cuyahoga County, Ohio with respect to any dispute, controversy or claim arising out of or relating to the sale and delivery of the Products.

21. **Entire Agreement.** These Terms, along with the terms set forth in the main body of any Quote, forms the entire agreement between the Buyer and Seller and constitutes the final, complete and exclusive expression of the terms of sale. In the event of a conflict between any term set forth in the main body of a Quote and these Terms, the terms set forth in the main body of the Quote shall prevail. All prior or contemporaneous written or oral agreements or negotiations with respect to the subject matter shall have no effect. These Terms may not be modified unless in writing and signed by an authorized representative of Seller.

22. **Compliance with Laws.** Buyer agrees to comply with all applicable laws, regulations, and industry and professional standards, including those of the United States of America, and the country or countries in which Buyer may operate, including without limitation the U.S. Foreign Corrupt Practices Act ("FCPA"), the U.S. Anti-Kickback Act ("Anti-Kickback Act"), U.S. and E.U. export control and sanctions laws ("Export Laws"), the U.S. Food Drug and Cosmetic Act ("FDCA"), and the rules and regulations promulgated by the U.S. Food and Drug Administration ("FDA"), each as currently amended. Buyer agrees to indemnify, defend, and hold harmless Seller from the consequences of any violation of such laws, regulations and standards by Buyer, its employees or agents. Buyer acknowledges that it is familiar with all applicable provisions of the FCPA, the Anti-Kickback Act, Export Laws, the FDCA and the FDA and certifies that Buyer will adhere to the requirements thereof and not take any action that would make Seller violate such requirements. Buyer represents and agrees that Buyer will not make any payment or give anything of value, directly or indirectly, to any governmental official, foreign political party or official thereof, candidate for foreign political office, or commercial entity or person, for any improper purpose, including the purpose of influencing such person to purchase Products or otherwise benefit the business of Seller. Buyer further represents and agrees that it will not receive, use, service, transfer or ship any Product from Seller in a manner or for a purpose that violates Export Laws or would cause Seller to be in violation of Export Laws.