



Electric Expansion Valve

Type SEH-P

SPORLAN



SEH-P ELECTRIC EXPANSION VALVE

Sporlan is pleased to introduce the **SEH-P**, the newest addition to the family of large Electric Expansion Valves, and the largest valve approved for air-cooled R-410A applications. Featuring a straight through configuration, this EEV provides an alternative to the existing angle configuration of the SEHI-400. Contact your local Sales Engineer for assistance with sizing a Sporlan EEV for your application, or selecting a suitable controller to optimize your system's performance.

FITTINGS	'A'
11X11 ODF	9.88" (251 mm)
11X13 ODF	9.88" (251 mm)
11X17 ODF	10.25" (260 mm)
13X13 ODF	9.88" (251 mm)
13X17 ODF	10.25" (260 mm)

Dimensions in inches (mm)

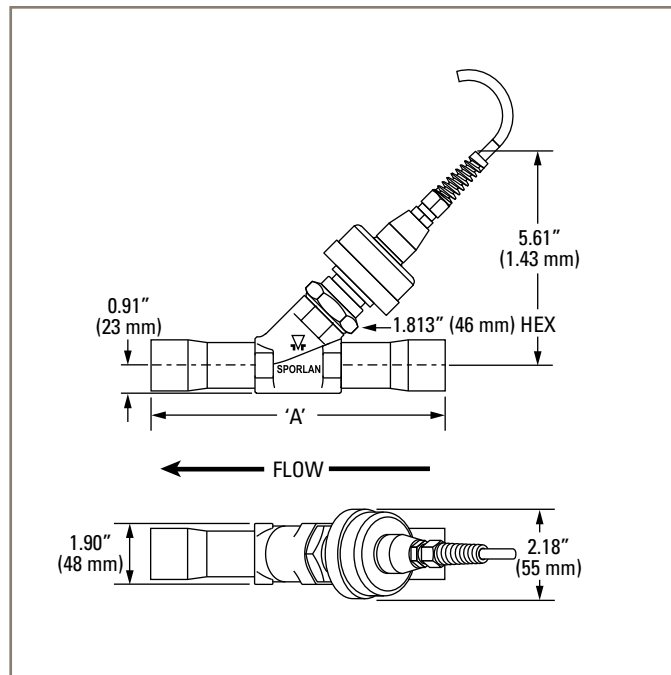

SPECIFICATIONS

Motor Type	Permanent magnet bipolar internal (wet) motor
Compatible Refrigerant	All common HCFC and HFC refrigerants, including R-410A
Compatible Oil	All common mineral, polyester and alkylbenzene oils
Supply Voltage	12 volts DC +/-10%
Cable Type	Hermetic (20' Standard)
Phase Resistance	75 ohms +/-10%
Stepping Current	160 mA/winding
Holding Current	Not recommended
Number of Steps	6386 Full Steps
Step Rate	200/second (L/R) 400/second recommended (properly configured current chopper)
Full Stroke Transit Time	32/16 seconds (Voltage/Current)
Initialization	7500 steps closing
Overdriving	Recommend one 10% overdrive closed per day (overdriving open not permitted)
MRP / MWP	620 psig (43 bar)
MOPD	450 psid (31 bar)
Max Internal Leakage	100 cc/min @ 100 psid (6.9 bar) dry air (forward flow only)
Max External Leakage	.10 oz/yr at 300 psig (2.8 gram/yr @ 20 bar)
Fluid Temperature Range	-50°F to 155°F (-40°C to 68°C)
Ambient Temperature Range	-50°F to 140°F (-40°C to 60°C)
Installation Maximum Temperature	250°F (121°C) for 15 minutes
Relative Humidity	0-100% (Condensing)
Materials of Construction	Brass, copper, stainless steel, synthetic seals

FULL STROKE CAPACITIES - TONS (AT EVAPORATOR TEMPERATURE °F)

Capacity is calculated at full stroke, with no reserve capacity. Valve should be selected with consideration given to entire range of potential system conditions.

R-134a

REFRIGERANT	40°F									20°F									0°F								
	Pressure Drop Across Valve (psid)																										
	40	60	80	100	120	140	160	180	40	60	80	100	120	140	160	180	40	60	80	100	120	140	160	180			
R-134a	197	241	278	311	340	368	393	417	187	230	265	296	325	351	375	398	178	218	252	282	308	333	356	378			

R-410A

REFRIGERANT	40°F									20°F									0°F								
	Pressure Drop Across Valve (psid)																										
	80	120	160	200	240	280	320	360	80	120	160	200	240	280	320	360	80	120	160	200	240	280	320	360			
R-410A	282	345	399	446	488	528	564	598	275	337	389	435	477	515	550	584	267	327	378	423	463	500	535	567			

REFRIGERANT	-20°F									-40°F								
	Pressure Drop Across Valve (psid)																	
	80	120	160	200	240	280	320	360	80	120	160	200	240	280	320	360		
R-410A	258	316	365	408	447	483	516	548	249	305	352	394	431	466	498	528		

R-22, R-404A, R-407A, R-407C, R-422D, R-507

REFRIGERANT	40°F									20°F									0°F								
	Pressure Drop Across Valve (psid)																										
	75	100	125	150	175	200	225	250	75	100	125	150	175	200	225	250	75	100	125	150	175	200	225	250			
R-22	288	333	372	408	440	471	499	526	281	325	363	398	429	459	487	513	273	315	353	386	417	446	473	499			
R-404A	191	221	247	270	292	312	331	349	181	209	234	256	277	296	314	331	170	196	220	240	260	278	295	310			
R-407A	269	311	348	381	412	440	467	492	257	297	332	364	393	420	445	470	244	282	315	346	373	399	423	446			
R-407C	266	307	343	375	406	434	460	485	255	294	329	360	389	416	441	465	243	281	314	344	371	397	421	444			
R-422D	196	227	253	278	300	320	340	358	185	214	239	262	283	303	321	338	174	201	225	246	266	284	301	318			
R-507	187	216	241	264	286	305	324	341	177	204	228	250	270	289	307	323	167	193	215	236	255	272	289	305			

REFRIGERANT	-20°F									-40°F								
	Pressure Drop Across Valve (psid)																	
	75	100	125	150	175	200	225	250	75	100	125	150	175	200	225	250		
R-22	264	305	341	374	404	432	458	483	255	294	329	360	389	416	441	465		
R-404A	159	184	205	225	243	260	276	290	147	170	190	208	225	240	255	268		
R-407A	231	267	299	327	353	378	401	422	-	-	-	-	-	-	-			
R-407C	232	267	299	328	354	378	401	423	-	-	-	-	-	-	-			
R-422D	163	188	210	230	249	266	282	297	-	-	-	-	-	-	-			
R-507	156	180	201	220	238	254	270	284	145	167	187	205	221	236	251	264		

FULL STROKE CAPACITIES - kW (AT EVAPORATOR TEMPERATURE °C)

Capacity is calculated at full stroke, with no reserve capacity. Valve should be selected with consideration given to entire range of potential system conditions.

R-134a

REFRIGERANT	5°C									-10°C									-20°C								
	Pressure Drop Across Valve (bar)																										
	2.5	4	5.5	7	8.5	10	11.5	13	2.5	4	5.5	7	8.5	10	11.5	13	2.5	4	5.5	7	8.5	10	11.5	13			
R-134a	657	831	975	1100	1212	1315	1410	1499	616	779	914	1031	1136	1232	1322	1405	588	743	872	983	1084	1175	1260	1340			

R-410A

REFRIGERANT	5°C									-10°C									-20°C								
	Pressure Drop Across Valve (bar)																										
	5	8	11	14	17	20	23	26	5	8	11	14	17	20	23	26	5	8	11	14	17	20	23	26			
R-410A	944	1194	1400	1579	1740	1888	2024	2152	912	1153	1353	1526	1681	1824	1956	2079	888	1123	1317	1486	1637	1776	1904	2024			

REFRIGERANT	-30°C									-40°C								
	Pressure Drop Across Valve (bar)																	
	5	8	11	14	17	20	23	26	5	8	11	14	17	20	23	26		
R-410A	861	1089	1277	1441	1588	1722	1847	1963	832	1052	1234	1392	1534	1663	1784	1897		

FULL STROKE CAPACITIES - kW (AT EVAPORATOR TEMPERATURE °C)

Capacity is calculated at full stroke, with no reserve capacity. Valve should be selected with consideration given to entire range of potential system conditions.

R-22, R-404A, R-407A, R-407C, R-422D, R-507

REFRIGERANT	5°C								-10°C								-20°C							
	Pressure Drop Across Valve (bar)																							
	4	6	8	10	12	14	16	18	4	6	8	10	12	14	16	18	4	6	8	10	12	14	16	18
R-22	891	1092	1261	1409	1544	1668	1783	1891	860	1053	1216	1359	1489	1608	1719	1824	836	1024	1183	1322	1449	1565	1673	1774
R-404A	589	721	833	931	1020	1102	1178	1250	547	670	774	865	948	1024	1095	1161	517	633	731	817	895	967	1034	1096
R-407A	834	1021	1179	1319	1444	1560	1668	1769	783	959	1107	1238	1356	1465	1566	1661	746	914	1055	1180	1293	1396	1493	1583
R-407C	819	1003	1158	1295	1419	1532	1638	1738	773	946	1093	1221	1338	1445	1545	1639	740	906	1046	1170	1281	1384	1479	1569
R-422D	606	742	857	958	1050	1134	1212	1286	562	688	794	888	973	1051	1124	1192	530	649	749	837	917	991	1059	1123
R-507	577	706	815	912	999	1079	1153	1223	534	655	756	845	926	1000	1069	1134	506	620	716	800	877	947	1012	1074

REFRIGERANT	-30°C								-40°C							
	Pressure Drop Across Valve (bar)															
	4	6	8	10	12	14	16	18	4	6	8	10	12	14	16	18
R-22	814	997	1151	1287	1409	1522	1627	1726	787	963	1112	1244	1362	1471	1573	1669
R-404A	483	592	683	764	837	904	966	1025	451	553	638	713	782	844	902	957
R-407A	710	869	1004	1122	1229	1328	1420	1506	–	–	–	–	–	–	–	
R-407C	709	868	1002	1120	1227	1326	1417	1503	–	–	–	–	–	–	–	
R-422D	498	610	705	788	863	932	997	1057	–	–	–	–	–	–	–	
R-507	476	583	673	753	824	890	952	1010	445	545	629	703	770	832	889	943

Liquid Temperature Correction Factors

°F	0	10	20	30	40	50	60	70	80	90	100	110	120	130	140
°C	-18	-12	-7	-1	4	10	16	21	27	32	38	43	49	54	60
R-22	1.56	1.51	1.45	1.40	1.34	1.29	1.23	1.17	1.12	1.06	1.00	0.94	0.88	0.82	0.76
R-134a	1.70	1.63	1.56	1.49	1.42	1.36	1.29	1.21	1.14	1.07	1.00	0.93	0.85	0.78	0.71
R-404A	2.04	1.94	1.84	1.74	1.64	1.54	1.43	1.33	1.22	1.11	1.00	0.89	0.77	0.65	0.53
R-407A	1.76	1.68	1.61	1.53	1.46	1.39	1.31	1.24	1.16	1.08	1.00	0.92	0.83	0.74	0.64
R-407C	1.69	1.62	1.55	1.49	1.42	1.35	1.28	1.21	1.14	1.07	1.00	0.93	0.85	0.77	0.69
R-410A	1.79	1.71	1.63	1.55	1.47	1.40	1.32	1.24	1.16	1.08	1.00	0.92	0.83	0.73	0.62
R-507	1.99	1.89	1.79	1.69	1.59	1.50	1.40	1.30	1.20	1.10	1.00	0.89	0.78	0.66	0.51
R-422D	1.99	1.90	1.80	1.70	1.60	1.50	1.41	1.31	1.20	1.10	1.00	0.90	0.79	0.68	0.57

⚠ WARNING – USER RESPONSIBILITY

Failure or improper selection or improper use of the products described herein or related items can cause death, personal injury and property damage.

This document and other information from Parker Hannifin Corporation, its subsidiaries and authorized distributors provide product or system options for further investigation by users having technical expertise.

The user, through its own analysis and testing, is solely responsible for making the final selection of the system and components and assuring that all performance, endurance, maintenance, safety and warning requirements of the application are met. The user must analyze all aspects of the application, follow applicable industry standards, and follow the information concerning the product in the current product catalog and in any other materials provided from Parker or its subsidiaries or authorized distributors.

To the extent that Parker or its subsidiaries or authorized distributors provide component or system options based upon data or specifications provided by the user, the user is responsible for determining that such data and specifications are suitable and sufficient for all applications and reasonably foreseeable uses of the components or systems.

For safety information see the Safety Guide at www.parker.com/safety or call 1-800-CParker.

OFFER OF SALE

The items described in this document are hereby offered for sale by Parker Hannifin Corporation, its subsidiaries or its authorized distributors. This offer and its acceptance are governed by the provisions stated in the detailed "Offer of Sale" available at www.parker.com.

FOR USE ON AIR CONDITIONING and REFRIGERATION SYSTEMS ONLY

