



# Electric Hot Gas Bypass Valves

SPORLAN



ENGINEERING YOUR SUCCESS.

## 10 FEATURES AND BENEFITS



- Direct temperature control
- Tight shutoff when closed
- Can be interfaced with direct digital controls or other building management systems
- Functions as a standalone temperature control when used with a Sporlan TCB
- Capacities up to 40 tons R-410A
- Suitable for use with CFC, HCFC and HFC refrigerants
- Proven reliable step motor design
- High force output for unparalleled reliability
- Corrosion resistant materials used throughout
- Low power consumption – 4 watts

### OPERATION

The SDR series Electric Hot Gas Bypass valves (EHGB) modulate by the electronically controlled rotation of a step motor driving a gear train to position a pin or piston in a port, refer to Figure 4. The motor is a two phase, bipolar, 12 volt DC, permanent magnet rotor style with a step angle of 3.6°. When supplied with the proper signal stream, the motor will rotate, driving a gear train to increase mechanical advantage. The output of the gear train rotates a threaded lead screw by a precise and repeatable amount. The plunger converts the rotational motion to a linear force. The pin or piston is directly connected to the plunger providing high force to both open and close the valve. A pressure balanced piston in the SDR-4 valve reduces flow induced motor load and synthetic seating materials ensure tight shutoff when the valves are closed. All materials are rated for discharge gas temperature and pressures. The valves are corrosion resistant and have copper connections for ease in installation.

### CONTROLLERS

The SDR series valves all require electronic controllers to operate. The controller must be capable of:

1. Sensing a pressure or temperature
2. Calculating valve step position
3. Driving the step motor to properly achieve the desired valve position.

Many off-the-shelf controllers are available for the sensing function, but few also incorporate the algorithms and drive circuitry necessary to modulate the valve. Sporlan makes available two devices that can accomplish any or all of the required functions – the TCB Temperature Control Board, and IB Interface Boards. The TCB, when supplied with the optional on board temperature set-point potentiometer, constitutes a standalone single point temperature control for the SDR series valves. The TCB may also be used as an interface between the SDR

valve and an external controller or Building Management System. When used as an interface, the TCB will accept a 4-20 milliamp, 0-10 volt DC, 5 volt DC logic level command, or a 120 volt AC Pulse Width Modulated signal. The IB series interface boards are newer versions that provide an economical alternative to the TCB when only the 0-10 volt and 4-20 milliamp inputs are required. For a complete description please request Bulletin 100-50-1 for the TCB, and Bulletin 100-50-2 for the IB.

Whether using the TCB as an interface or as a standalone control, best results are obtained by sensing the discharge air or chilled water temperature, regardless of the physical location of the valve. In Figures 1-3, the TCB and sensor locations are illustrated. Other arrangements are possible, contact Sporlan Division, Parker Hannifin for further suggestions.

### APPLICATION

Sporlan Hot Gas Bypass valves provide a precise method of compressor capacity control in place of cylinder unloaders or the handling of unloading requirements below the last step of cylinder unloading. Both mechanical and electronically controlled valves are offered by Sporlan. Mechanical valves, which open on a decrease in suction pressure, are covered in Bulletin 90-40.

Electronically controlled valves, referred to as EHGB, are generally used to directly control the temperature of the cooled medium with the use of temperature sensors and electronic controllers. They can be set to automatically maintain a desired minimum evaporating temperature regardless of the decrease in evaporator load. As a result they are ideal for close tolerance temperature applications such as environmental chambers and process cooling.

When used in air conditioning applications it is usual to limit evaporator temperature to 26°F or higher to prevent frost buildup. Depending on the design of the evaporator, discharge air should be limited to approximately 36°F.

## SYSTEM CONSIDERATIONS

Condensed liquid in an inactive hot gas line can create noise and vibration when the hot gas is enabled. This may be prevented in the following ways:

1. When the hot gas line is above the evaporator, the piping should be free draining toward the evaporator to prevent liquid and oil pooling in the piping.
2. If the hot gas line is below the evaporator, a reverse trap should be used to assure that the hot gas is injected from above the distributor or suction line. This will prevent the hot gas line from being filled with liquid when the hot gas is inactive.
3. The hot gas line should be insulated to prevent excessive condensation in piping, particularly if run through a cool area.

There are three common ways to apply hot gas bypass to systems. The preferred method is to inject the hot gas into the distributor between the expansion valve and evaporator as shown in Figure 1. The second method is to inject the hot gas after the evaporator, refer to Figure 2. The final method involves bypassing the hot gas near the compressor, see Figure 3.

### Bypass to Evaporator Inlet with Distributor

This method of application, illustrated in Figure 1, provides distinct advantages over the other methods, especially for unitary or field built-up units where the high and low side are close coupled. It is also applicable on systems with remote condensing units, especially when the evaporator is located below the condensing unit (See Figure 1).

The primary advantage of this method is that the EHGB can directly control the temperature of the cooled fluid. A sensor placed in the air off the evaporator or on the chilled water line of a chiller can cause the EHGB to modulate to maintain the desired setpoint temperature. In addition, the system thermostatic expansion valve will respond to the increased superheat of the vapor leaving the evaporator and will provide the liquid required for

desuperheating. The evaporator serves as an excellent mixing chamber for the bypassed hot gas and the liquid-vapor mixture from the expansion valve. This ensures a dry vapor reaching the compressor suction. Oil return from the evaporator is also improved since the velocity in the evaporator is kept high by the hot gas.

### Sporlan 1650R Series Distributor or ASC

To accomplish this application, two methods are available:

1. Bypass to Sporlan 1650R series distributor with an auxiliary side connection
2. Bypass to Sporlan ASC series Auxiliary Side Connector

Method 1 is normally utilized on factory assembled or unitary units where hot gas bypass is initially designed into the system. The 1650R series distributor allows the hot gas to enter downstream of the distributor nozzle. Method 2 is applicable on field built-up systems or on existing systems where the standard refrigerant distributor is already installed on the evaporator.

Some caution is necessary in either of these methods. If the distributor circuits are sized properly for normal cooling duty, the flow of hot gas through the circuits may cause excessive pressure drop and/or noise. Therefore, it is recommended that the distributor circuits be selected one size larger than for straight cooling duty. For complete technical details on the 1650R series distributor and the ASC series Auxiliary Side Connector, refer to Bulletin 20-10 and supplemental bulletins.

### Valve / Equipment Location and Piping

When the evaporator is located below the compressor on a remote system, bypass to the evaporator inlet is still the best method of hot gas bypass to ensure good oil return to the compressor. When this is done, the bypass valve must be located at the compressor rather than at the evaporator section. This will ensure obtaining rated capacity from the bypass valve at the conditions for which it was selected. If the evaporator is above or on the same level as the compressor, this valve location will also eliminate

Figure 1

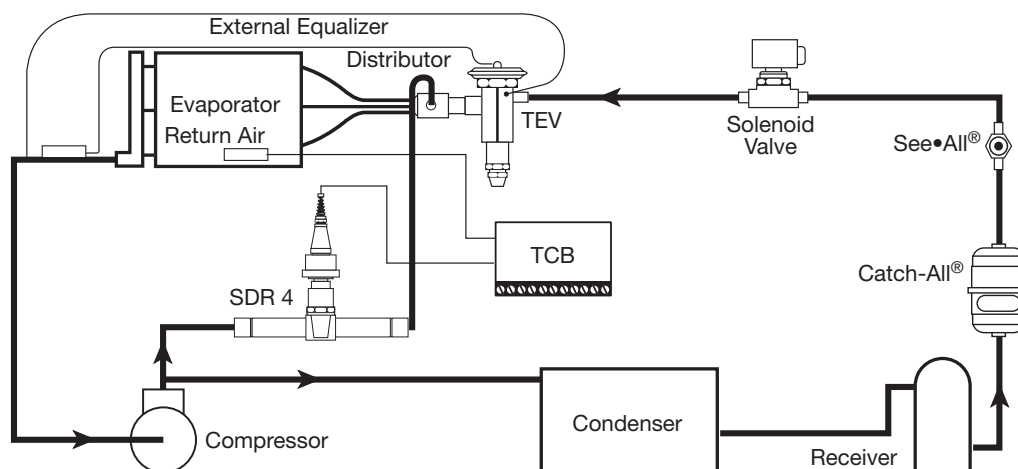

the possibility of hot gas condensing in the long bypass line and running back into the compressor during the off cycle. Whenever hot gas bypass to the evaporator inlet is necessary for a system with two or more evaporator sections each with its own TEV (no liquid line solenoid valves) but handling the same load, two methods may be used to avoid operating interference between sections:

1. Use a separate discharge bypass valve for each evaporator section.
2. Use one discharge bypass valve to feed two bypass lines each with a check valve between the bypass valve and the evaporator section inlet. The check valves will prevent interaction between the TEV's when the bypass valve is closed.

Caution - introduction of hot gas between the expansion valve and a standard distributor should be avoided. The hot gas will create a higher than expected pressure drop when flowing through distributor nozzles or throats and tubes that have been sized for liquid refrigerant flow. Careful testing must be done to assure system performance.

### Bypass to Evaporator Inlet without Distributor

Many refrigeration systems and water chillers do not use refrigerant distributors but may require some method of compressor capacity control. This type of application provides the same advantages as bypassing hot gas to the evaporator inlet with a distributor. All information relating to bypassing hot gas to the evaporator inlet with a distributor, except that concerning distributors or ASCs, also applies to bypassing to the evaporator inlet without a distributor.

### Bypass to Suction Line

On many applications, it may be necessary to bypass directly into the suction line. Refer to Figure 2 and 3. This is generally true of systems with multi-evaporators or remote condensing units, as well as on existing systems where it is easier to connect to the suction line than the evaporator inlet. When hot gas is bypassed directly into the suction line, the danger of overheating the compressor and trapping the oil in the evaporator exists. As the suction temperatures rise, the discharge temperature also starts to increase. This can

cause breakdown of the oil and refrigerant with the possible result being a compressor burnout. This method offers added flexibility for multi-evaporator systems or remote systems because the hot gas bypass components can be located at the condensing unit. However, to ensure oil return special care must be taken in the system piping.

### Desuperheating Thermostatic Expansion Valve

On those applications where the hot gas must be bypassed directly into the suction line downstream of the main expansion valve's bulb, an auxiliary thermostatic expansion valve, commonly called a desuperheating TEV or a liquid injection valve, is required. The purpose of this valve is to supply enough liquid refrigerant to cool the hot discharge gas to the recommended suction temperature. Most compressor manufacturers specify a maximum suction gas temperature of 65°F. For these requirements, special desuperheating thermostatic charges are available which will control at the proper superheat to maintain the suction gas at or below 65°F. For applications requiring suction gas temperatures appreciably below 65°F, contact Sporlan or the compressor manufacturer for assistance. In all cases the maximum permissible suction gas temperature published by the compressor manufacturer must be followed. Request Bulletin 90-40 for more information.

Another, and possibly more energy efficient, method of protecting the compressor from the effects of hot suction gas is the use of the Sporlan Y1037 valve. The Y1037 Temperature Responsive Expansion Valve, or TREV, injects liquid into the suction of the compressor in response to changes in the discharge temperature of the compressor. The Y1037 is not refrigerant specific and a variety of discharge temperature setpoints are available. The compressor manufacturer should be consulted for the highest permissible discharge temperature for selection of the TREV. This system, may be more efficient than the desuperheating TEV shown in Figure 3. The TREV injects liquid only when required for purposes of limiting discharge temperature, while the desuperheating TEV injects liquid to constantly maintain a specific superheat in the

Figure 2

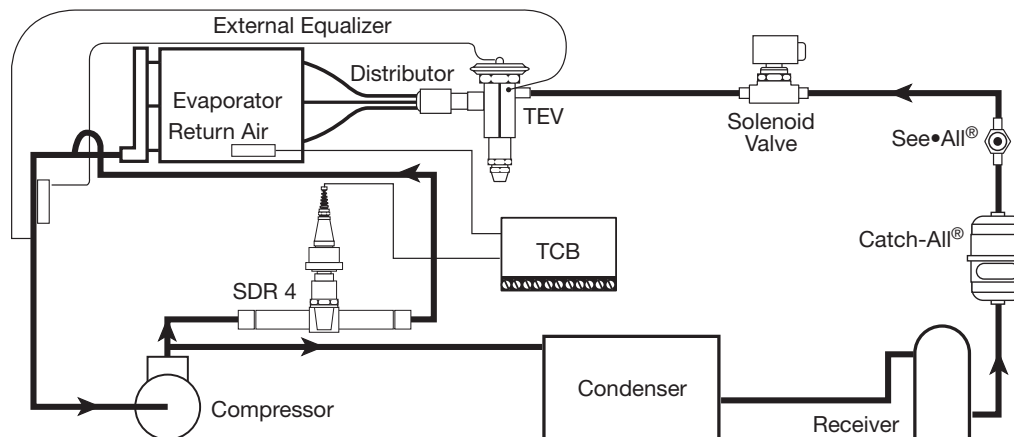
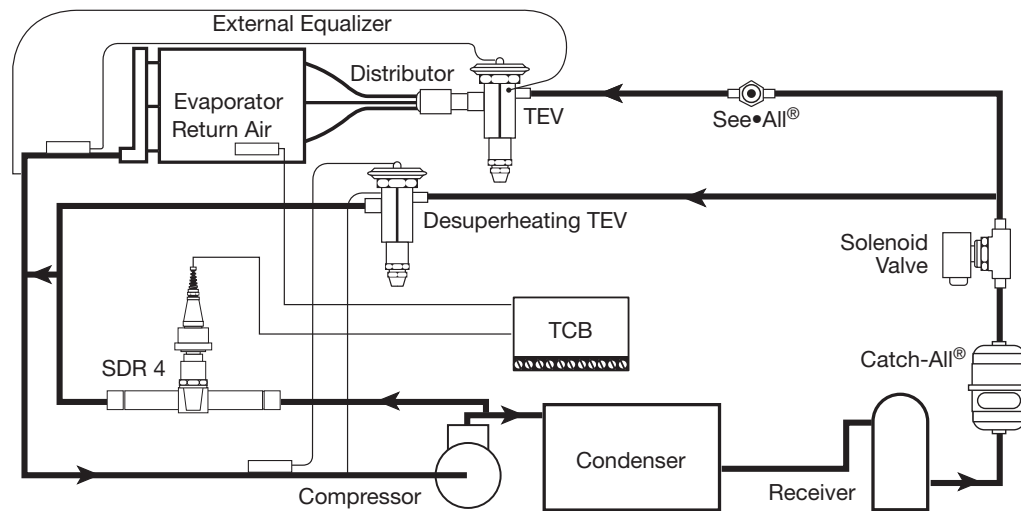

Figure 3



suction vapor. In instances where the suction gas may be cool enough to not need further liquid injection, the TEV will not feed, saving energy. Request Bulletin 10-10-2 for more information.

### Valve / Equipment Location and Piping

As indicated earlier, the bypass valve and hot gas solenoid valve (if used) must be located as near to the compressor as possible to ensure obtaining rated capacity from the EHGB valve at the conditions for which it was selected. On some systems with remote condensing units, the evaporator will be located below the compressor. When this is the case, serious consideration should be given to bypassing the hot gas to the evaporator inlet to keep the compressor oil from being trapped in the evaporator or suction line. Consult with the compressor manufacturer for additional application data.

One of the most important points to remember when piping the discharge bypass valve and the desuperheating thermostatic expansion valve is that good mixing must be obtained before reaching the bulb location. Otherwise, the system operation may become unstable and the thermostatic expansion valve will hunt. This mixing can be accomplished two ways: use a suction line accumulator downstream of both connections with the auxiliary thermostatic expansion valve bulb downstream of the accumulator; tee the liquid-vapor mixture from the thermostatic expansion valve and the hot gas from the bypass valve together before connecting a common line to the suction line. The latter method is illustrated in Figure 3.

### Equalizing the EHGB

Unlike mechanical valves that require an equalization line to sense evaporator pressure, the EHGB valve needs no equalizer connections.

## GENERAL APPLICATION FACTORS

While the application discussion up to this point covers the basic types of applications, several additional factors must be considered. These are discussed below as they apply to all methods illustrated in Figures 1, 2, and 3.

### Paralleling Valves

If the hot gas bypass requirement on any system is greater than the capacity of the largest discharge bypass valve, these valves can be applied in parallel. The temperature settings of the paralleled valves should be the same to get the most sensitive performance. Since the TCB may only be used with a single valve, when two valves are used in parallel for capacity, the IB should be used with an external controller because of its higher power rating.

### Piping Suggestions

Figures 2, 3, and 4 are piping schematics that illustrate the general location of the hot gas bypass valves in the system. Sporlan recommends that recognized piping references, such as equipment manufacturers' literature and the ASHRAE Handbook, be consulted for assistance with this subject. Sporlan is not responsible for system design, any damage arising from faulty system design, or from misapplication of its products. If these valves are applied in any manner other than as described in this bulletin, the Sporlan warranty is void.

Actual system piping must be done to protect the compressor at all times. This includes protection against overheating, slugging with liquid refrigerant, and trapping of oil in various system locations.

The inlet connections on the discharge bypass valve should be sized to match system piping requirements. Inlet strainers are available, but not normally supplied with solder type bypass valves. Just as with any refrigerant flow control devices, the need for an inlet strainer is a function of system cleanliness. Moisture and particles too small for the strainer are harmful to the system and must also be removed. Therefore, it is recommended that a Catch-All® Filter-Drier be applied in the liquid line and, if required, in the suction line. See Bulletin 40-10.

### Hot Gas Solenoid Valve

EHGBs are tight shutoff valves and systems employing them do not ordinarily need an additional hot gas solenoid valve. All step motor valves, however, will remain

at their current position if power is removed during operation. In some critical systems an additional hot gas solenoid may be desirable to ensure that no hot gas is bypassed during system or power failures. When used, the hot gas solenoid valve may be wired in series with a bi-metal thermostat fastened to the discharge line close to the compressor. This causes the solenoid valve to close if the discharge line temperature becomes excessive. Complete selection information is given in the Sporlan Solenoid Bulletin 30-10.

## THE NEED FOR HEAD PRESSURE CONTROL

A discharge bypass valve can be applied on any system that experiences undesirable compressor cycling during periods of low load or for direct temperature control of any evaporator. Normally, when hot gas bypass is used for capacity control during periods of low load, outdoor ambient may be below 70°F. Therefore, all air cooled systems that utilize hot gas bypass for capacity control should have some type of head pressure control to maintain satisfactory performance. Sporlan Bulletin 90-30 Head Pressure Control Valves has complete selection and application information.

## SPECIFICATIONS

Sporlan Electric Hot Gas Bypass valves utilize many of the proven construction features of Sporlan step motor electric expansion valves and evaporator control valves. They are constructed of the finest materials — those best suited for the specific purpose intended for each valve component. This ensures long life and dependable service.

## SELECTION

The selection of a hot gas bypass valve and the necessary companion devices is simplified if complete system information is available. This will result in the most economical selection because the components will match the system requirements. Besides the discharge bypass valve, a specific application may require a hot gas solenoid valve, an auxiliary side connection distributor or ASC adapter, and a desuperheating TEV with a companion liquid line solenoid valve. Once the type of application (review Application Section pages 3-6) is determined, the necessary valves can be selected from the information discussed in this section.

The selection of a Sporlan Electric Hot Gas Bypass valve involves five basic items:

1. Refrigerant – valve capacities may vary considerably for the different refrigerants.
2. Desired outlet fluid temperature – depending on the system, this value must be set to prevent coil icing and/or compressor short cycling. For example, this may be 32-34°F for a water chiller; 26-28°F for a normal air conditioning system; and, the freezing temperature of the specific product for a refrigeration system.
3. Compressor capacity (tons) at minimum allowable evaporating temperature – consult compressor capacity ratings for this value.
4. Minimum evaporator load (tons) at which the system is to be operated – most systems are not required to operate down to zero load but this value will depend on the type of system. For example, most air conditioning systems only operate down to 15-25% of full load. However, air conditioning systems for data processing and “white” rooms, and most refrigeration systems may be required to bypass to zero load conditions.
5. Condensing temperature when minimum load exists – since the capacity ratings of the bypass valves are a function of condensing temperature, it is vital that proper head pressure is maintained, especially during low load operation. As the capacity table indicates, a condensing temperature of 80°F is considered the minimum allowable for satisfactory systems operation. See Bulletin 90-30 for information on Sporlan’s Head Pressure Control Valves.

The hot gas bypass valve must be selected to handle the difference between items 3 and 4 above. If the minimum evaporator load (item 4) is zero, the hot gas bypass requirement is simply the compressor capacity at the minimum allowable evaporating temperature (item 3). The following discussion on Capacity Ratings and the example show how these factors affect a selection on a typical air conditioning system. Capacity Ratings - As the Hot Gas Bypass Valve Capacity Table indicates, valve ratings are dependent on the evaporating and condensing temperature at the reduced load condition and the refrigerant used. Therefore, once this information and the hot gas bypass requirement in tons is determined, a hot gas bypass valve can be selected.

Example – Select a hot gas bypass valve for a 30 ton, Refrigerant 22, air conditioning system with 67% cylinder unloading (4 of 6 cylinders unloaded). Normal operating conditions are 45°F evaporating temperature and 120°F condensing temperature with a minimum condensing temperature of 80°F due to head pressure control. When the evaporator load drops below the last step of cylinder unloading, it is necessary to keep the system on the line to maintain proper space temperatures and avoid frosting of the coil. From the compressor manufacturer’s capacity table, the compressor capacity in tons at the minimum allowable evaporating temperature is approximately 10 tons. If the system had to be on the line down to zero load, the bypass valve would have to bypass 10 tons of hot gas. With the necessary system factors — R-22, 26°F evaporating temperature at the reduced load condition, and 80°F condensing temperature — the capacity table is checked for a valve which can handle the 10 ton requirement. The SDR-4 has sufficient capacity for this condition. Both 7/8” ODF and 1-1/8” ODF connections are available on the SDR-4 for piping convenience, and the proper size should be specified when ordering. See ordering information.

## SPECIFICATIONS

**MOTOR TYPE:**

2 phase permanent magnet, 2 coil bipolar

**SUPPLY VOLTAGE:**

12 DC, -5% + 10%, measured at the valve leads

**CONNECTIONS:**

4 lead, 18 AWG, PVC insulation jacketed cable

**PHASE RESISTANCE:**

75 ohms per winding ± 10%

**CURRENT RANGE: .**

.131 to .215 amps/winding; .262 to .439 amps with 2 windings energized

**MAXIMUM POWER:**

4 watts

**INDUCTANCE PER WINDING:**

62 ± 20% mH

**REQUIRED STEP RATE:**

200 steps per second, other rates must be tested and approved

**NUMBER OF STEPS:**

SDR-3 & 3x - 3193 steps, SDR-4 - 6386 steps

**RESOLUTION: .**

.0000783 inches/step (.02 mm/step)

**TOTAL STROKE:**

SDR - 3 & 3x .250 inches (64mm)

SDR-4 - .500 inches (12.7 mm)

**MAXIMUM ALLOWABLE INTERNAL LEAKAGE:**

less than 100 cc/min at 100 psi

**MAXIMUM ALLOWABLE EXTERNAL LEAKAGE:**

less than .10 oz./year at 300 psig (.2 gr/yr at 20 bar)

**MAXIMUM RATED PRESSURE (MRP):**

700 psig (48 bar)

**OPERATING TEMPERATURE RANGE:**

Fluid

-40°F to 240°F (-40°C to 116°C)

Ambient

-40°F to 140°F (-40°C to 60°C)

**MAXIMUM DEHYDRATION TEMPERATURE:**

250°F (120°C)

**COMPATIBILITY:**

all common CFC, HCFC and HFC refrigerants including R-410A except ammonia; all common Mineral, Polyolester and Alkylbenzene oils

**MATERIALS OF CONSTRUCTION:**

copper - fittings; brass - valve body, motor housing, and adaptors; synthetic materials - seating and seals

## DIMENSIONS

Figure 4

Dimensions in inches (mm)

**SDR-3, 3x**

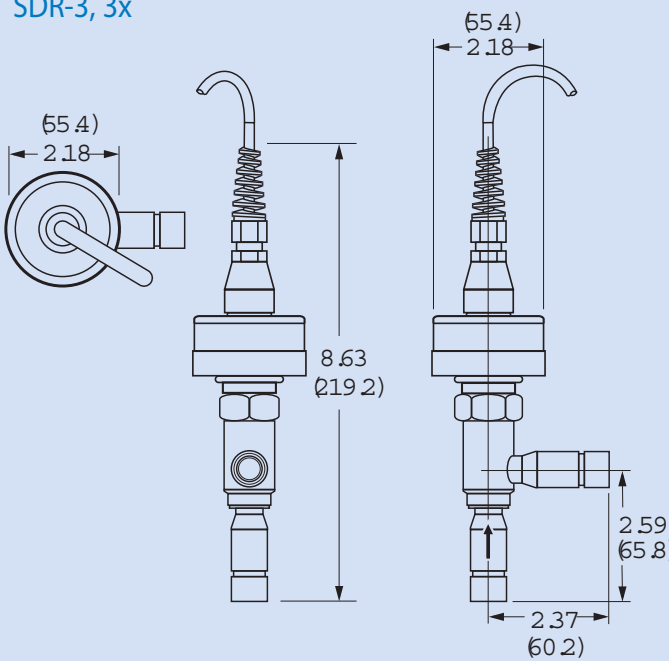

Fitting Size Available - 3/8, 1/2 or 5/8 ODF

**SDR-4**

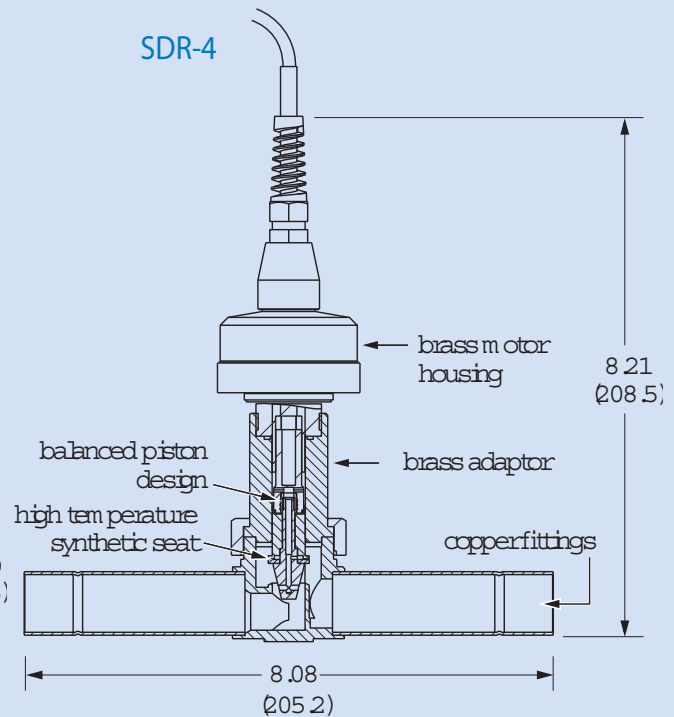

Fitting Size Available - 7/8, or 1-1/8 ODF

MINIMUM ALLOWABLE EVAPORATOR TEMPERATURE AT REDUCED LOAD °F – Tons																			
Refrigerant	Model	40			26			20			0			-20			-40		
		Condensing Temperature °F																	
		80	100	120	80	100	120	80	100	120	80	100	120	80	100	120	80	100	120
22	SDR-3	5.4	6.9	8.7	5.4	6.7	8.3	5.3	6.7	8.1	4.9	6.2	7.6	4.6	5.8	7.1	4.3	5.5	6.8
	SDR-3x	9.8	12.6	15.9	9.9	12.7	16.0	9.9	12.7	16.0	10.0	12.8	16.2	10.1	13.0	16.4	10.2	13.2	16.6
	SDR-4	17.9	25.2	34.8	19.4	26.4	35.8	19.8	28.0	36.2	20.9	28.1	37.0	21.6	28.7	37.5	22.0	29.8	37.8
134a	SDR-3	3.8	4.7	5.5	3.6	4.4	5.2	3.5	4.2	5.1	3.1	3.8	4.7	2.8	3.5	4.4	2.6	3.3	4.2
	SDR-3x	6.5	8.6	11.1	6.5	8.6	11.1	6.6	8.7	11.1	6.6	8.7	11.2	6.6	8.8	11.3	6.7	8.9	11.4
	SDR-4	13.3	18.4	23.8	14.2	19.1	24.4	14.5	19.3	24.6	15.2	19.9	25.0	15.6	20.2	25.3	15.8	20.4	25.5
404A/507	SDR-3	6.0	7.3	8.6	6.3	7.4	8.5	6.1	7.2	8.4	5.6	6.7	7.9	5.0	6.0	7.5	4.8	5.8	7.2
	SDR-3x	10.7	13.5	16.6	10.8	13.6	16.6	10.8	13.6	16.6	10.8	13.6	16.7	10.9	13.7	16.8	11.0	13.8	17.0
	SDR-4	19.9	26.2	31.8	23.1	29.7	35.9	23.7	30.1	36.2	25.0	31.2	37.0	24.3	29.8	35.0	26.6	32.8	38.8
407C	SDR-3	5.4	6.6	8.2	5.2	6.6	7.8	5.1	6.2	7.7	4.7	5.8	7.2	4.3	5.4	6.8	4.0	5.1	6.5
	SDR-3x	9.8	12.9	16.4	9.9	12.9	16.5	9.9	13.0	16.5	10.1	13.1	19.7	10.1	13.2	16.9	10.2	13.4	17.2
	SDR-4	18.3	25.0	34.1	19.8	27.8	35.0	20.3	27.5	35.6	21.6	27.8	36.7	22.4	28.6	37.7	23.0	29.3	38.6
410A	SDR-3	9.1	11.3	13.6	9.1	11.3	13.6	9.1	11.3	13.6	9.1	11.3	13.6	9.1	11.3	13.6	-	-	-
	SDR-3x	16.3	20.3	24.5	16.4	20.3	24.5	16.4	20.3	24.5	16.4	20.3	24.5	16.4	20.3	24.5	-	-	-
	SDR-4	29.7	39.9	49.7	32.3	41.8	51.2	33.1	42.5	51.8	35.0	44.0	53.1	36.1	45.0	54.0	-	-	-

Capacities are based on discharge temperature 50°F above isentropic compression, 0°F subcooling, 25°F superheat at the compressor and includes both the hot gas bypassed and the liquid refrigerant for desuperheating, regardless of whether the liquid is fed through the system thermostatic expansion valve or auxiliary desuperheating expansion valve.

MINIMUM ALLOWABLE EVAPORATOR TEMPERATURE AT REDUCED LOAD °C – kW																			
Refrigerant	Model	5			3			-7			-18			-29			-40		
		Condensing Temperature °C																	
		26	38	49	26	38	49	26	38	49	26	38	49	26	38	49	26	38	49
22	SDR-3	18.9	24.2	30.5	18.9	23.5	29.1	18.6	23.5	28.4	17.2	21.7	26.6	16.1	20.3	24.9	15.1	19.3	23.8
	SDR-3x	34.3	44.1	55.7	34.7	44.5	56.0	34.7	44.5	56.0	35.0	44.8	56.7	35.4	45.5	57.4	35.7	46.2	58.1
	SDR-4	62.7	88.2	122	67.9	92.4	125	69.3	98.0	127	73.2	98.4	130	75.6	100	131	77.0	104	132
134a	SDR-3	13.3	16.5	19.3	12.6	15.4	18.2	12.3	14.7	17.9	10.9	13.3	16.5	9.8	12.3	15.4	09.1	11.6	14.7
	SDR-3x	24.1	30.0	35.2	23.1	29.2	35.1	22.9	27.9	35.3	22.1	27.5	35.1	21.5	27.5	35.6	21.6	27.7	35.9
	SDR-4	46.6	64.4	83.3	49.7	66.9	85.4	50.8	67.6	86.1	53.2	69.7	87.5	54.6	70.7	88.6	55.3	71.4	89.3
404A/507	SDR-3	21.0	25.6	30.1	22.1	25.9	29.8	21.4	25.2	29.4	19.6	23.5	27.7	17.5	21.0	26.3	16.8	20.3	25.2
	SDR-3x	38.1	46.7	55.0	40.4	49.1	57.3	39.9	47.8	58.1	40.0	48.4	58.9	38.4	47.1	60.6	39.9	48.7	61.5
	SDR-4	69.7	91.7	111	80.9	104	126	83.0	105	127	87.5	109	130	85.1	104	123	93.1	115	136
407C	SDR-3	18.9	23.1	28.7	18.2	23.1	27.3	17.9	21.7	27.0	16.5	20.3	25.2	15.1	18.9	23.8	14.0	17.9	22.8
	SDR-3x	34.3	42.2	52.5	33.4	43.8	52.6	33.3	41.1	53.2	33.6	41.9	53.7	33.0	42.4	55.0	33.2	42.8	55.5
	SDR-4	64.1	87.5	119	69.3	97.3	123	71.1	96.3	125	75.6	97.3	128	78.4	100	132	80.5	103	135
410A	SDR-3	31.9	39.6	47.7	31.9	39.6	47.7	31.9	39.6	47.6	31.9	39.6	47.7	31.9	39.6	47.7	-	-	-
	SDR-3x	57.0	71.1	85.6	57.3	71.1	85.6	57.3	71.1	85.6	57.3	71.1	85.6	57.3	71.1	85.6	-	-	-
	SDR-4	104	140	174	113	147	179	116	149	183	122	154	186	126	158	189	-	-	-

Capacities are based on discharge temperature 28°C above isentropic compression, 0°C subcooling, 13°C superheat at the compressor and includes both the hot gas bypassed and the liquid refrigerant for desuperheating, regardless of whether the liquid is fed through the system thermostatic expansion valve or auxiliary desuperheating expansion valve.

## ELECTRIC HOT GAS BYPASS VALVE ORDERING INSTRUCTIONS

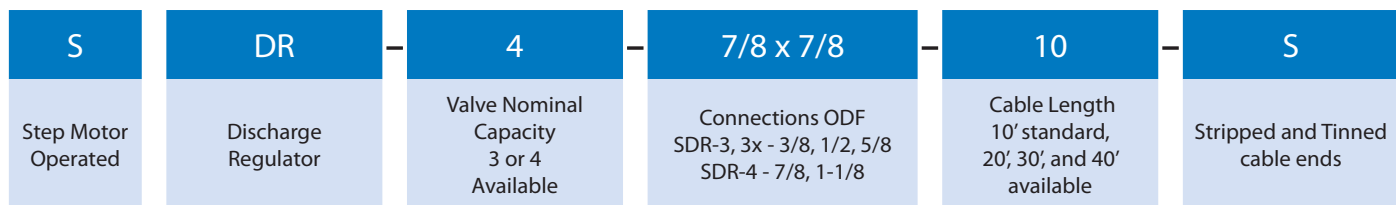

Parker Hannifin Ltd  
 Refrigeration and Air Conditioning Europe  
 Cortonwood Drive, Brampton  
 South Yorkshire S73 0UF  
 United Kingdom  
 phone +44 (0) 1226 273400  
 www.parker.com/race