



aerospace
climate control
electromechanical
filtration
fluid & gas handling
hydraulics
pneumatics
process control
sealing & shielding



Prep-Air[®] II

Miniature FRL Series

Catalogue PDE2591TCUK May 2016



ENGINEERING YOUR SUCCESS.

**CAUTION:**

Polycarbonate bowls and sight domes, being transparent and tough, are ideal for use with Filters and Lubricators. They are suitable for use in normal industrial environments, but should not be located in areas where they could be subjected to direct sunlight, an impact blow, nor temperatures outside of the rated range. As with most plastics, some chemicals can cause damage. Polycarbonate bowls and sight domes should not be exposed to chlorinated hydro-carbons, ketones, esters and certain alcohols. They should not be used in air systems where compressors are lubricated with fire-resistant fluids such as phosphate ester and di-ester types.

Metal bowls are recommended where ambient and/or media conditions are not compatible with polycarbonate bowls. Metal bowls resist the action of most such solvents, but should not be used where strong acids or bases are present or in salt laden atmospheres. Consult the factory for specific recommendations where these conditions exist.

TO CLEAN POLYCARBONATE BOWLS USE MILD SOAP AND WATER ONLY! DO NOT use cleansing agents such as acetone, benzene, carbon tetrachloride, gasoline, toluene, etc., which are damaging to this plastic.

Metal bowl guards are recommended for all applications.

**CAUTION:**

REGULATOR PRESSURE ADJUSTMENT – The working range of knob adjustment is designed to permit outlet pressures within their full range. Pressure adjustment beyond this range is also possible because the knob is not a limiting device. This is a common characteristic of most industrial regulators, and limiting devices may be obtained only by special design.

**WARNING**

FAILURE OR IMPROPER SELECTION OR IMPROPER USE OF THE PRODUCTS AND/OR SYSTEMS DESCRIBED HEREIN OR RELATED ITEMS CAN CAUSE DEATH, PERSONAL INJURY AND PROPERTY DAMAGE.

This document and other information from Parker Hannifin Corporation, its subsidiaries and authorized distributors provide product and/or system options for further investigation by users having technical expertise. It is important that you analyze all aspects of your application and review the information concerning the product or system in the current product catalog. Due to the variety of operating conditions and applications for these products or systems, the user, through its own analysis and testing, is solely responsible for making the final selection of the products and systems and assuring that all performance, safety and warning requirements of the application are met. The products described herein, including without limitation, product features, specifications, designs, availability and pricing, are subject to change by Parker Hannifin Corporation and its subsidiaries at any time without notice.

SALE CONDITIONS

The items described in this document are available for sale by Parker Hannifin Corporation, its subsidiaries or its authorized distributors. Any sale contract entered into by Parker will be governed by the provisions stated in Parker's standard terms and conditions of sale (copy available upon request).

Air Line Filters	
Series 14F	4 - 5
Air Line Coalescing Filters	
Series 10F	6 - 7
Air Line Regulators	
Series 14R.....	8 - 9
Air Line Filter / Regulators	
Series 14E.....	10 - 11
Air Line Lubricators	
Series 04L	12 - 13
Mounting Bracket Kits	14

14F Filters



Symbols

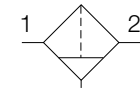

Manual drain

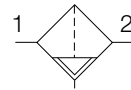

Auto drain

- Excellent water removal efficiency.
- Unique deflector plate that creates swirling of the air stream ensuring maximum water and dirt separation.
- 5 micron element standard.
- High Flow: 1/8" – 10 l/s[§]
1/4" – 11 l/s[§]

Options:

1	4	F	1	1	B	B	1
Port size		Bowl type		Element		Thread type	
1/8	0	Twist drain	1	5µ element	B	NPT	Blank
1/4	1	Automatic pulse drain	5			BSPP	1

Note: Bold options are standard

Port size	Description	Order code	Max bar	Height mm	Width mm	Depth mm
G1/8	Twist drain with 5µ element - Poly bowl	14F01BB1	10.3	107	43	39
G1/8	Auto pulse drain - 5µ element - Poly bowl	14F05BB1	17.2	107	43	39
G1/4	Twist drain with 5µ element - Poly bowl	14F11BB1	10.3	107	43	39
G1/4	Auto pulse drain - 5µ element - Poly bowl	14F15BB1	17.2	107	43	39

[§] L/s = 6.2 bar inlet and 0.3 bar pressure drop.
[‡] For polycarbonate bowl see Caution on page 2.

Specifications

Automatic pulse drain tube barb	4mm ^{OD} x 0.75 1/8	
Bowl capacity	30 cm ³	
Operating temperature	0°C to 52°C	
Max supply pressure	Polycarbonate bowl	0 to 10.3 bar
	Automatic pulse drain	0.7 to 17.2 bar
Standard filtration	5 micron	
Port size	G1/8 / G1/4	
Weight	0.180 gm	

Materials of Construction

Body	Zinc		
Bowl - Transparent	Polycarbonate		
Deflector, Element holder & Baffle	Plastic		
Drains	Twist drain	Body & Stem	Plastic
	Automatic pulse drain	Seals	Nitrile
		Piston & Seals	Nitrile
		Stem, Seat, Adaptor & Washers	Aluminium
Filter elements 5 micron (standard)	Plastic		
Seals	Nitrile		

Dimensions

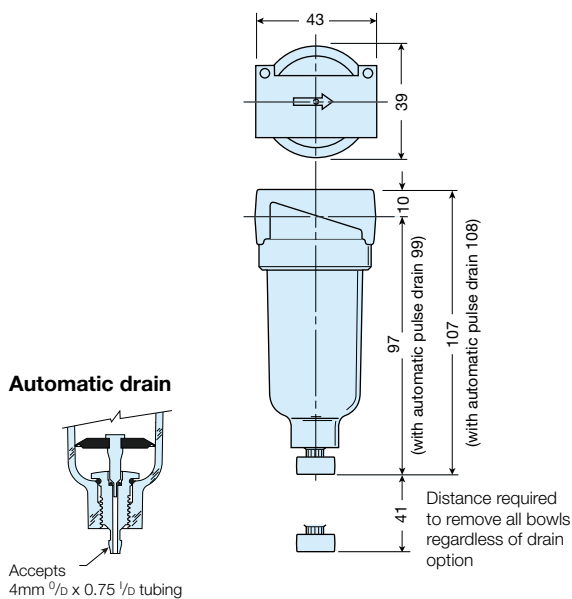

Flow Charts

5µ Filter

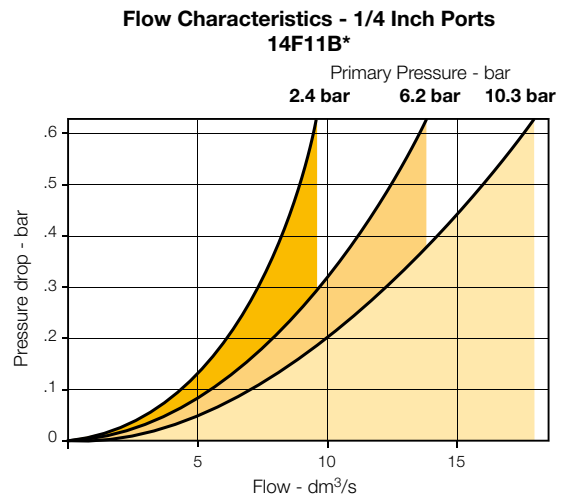
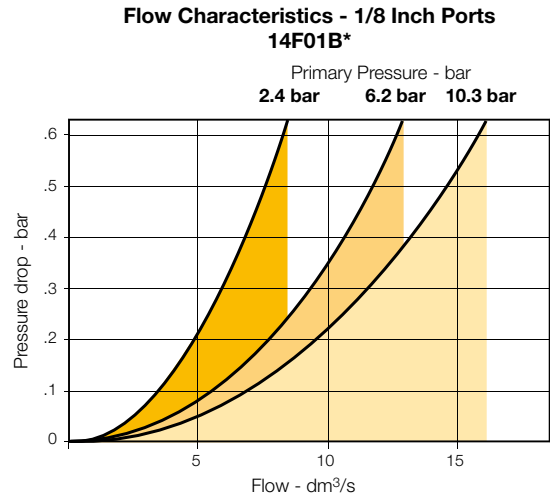

Accessories

Bowl kits, Poly bowl	Automatic pulse drain	PS408P
	Twist drain	PS404P
Filter element kits 5 micron		PS403P
Mounting bracket kit		PS417BP

10F Coalescing Filters

Symbol



- Removes liquid aerosols and sub-micron particles.
- Liquids gravitate to the bottom of the element and will not re-enter the airstream.
- Oil free air for critical applications, such as air gauging and pneumatic instrumentation and controls.
- 99.97% DOP efficiency.
- High Flow: Grade 6 Element
 1/8" – 8 l/s[§]
 1/4" – 9 l/s[§]

Options:

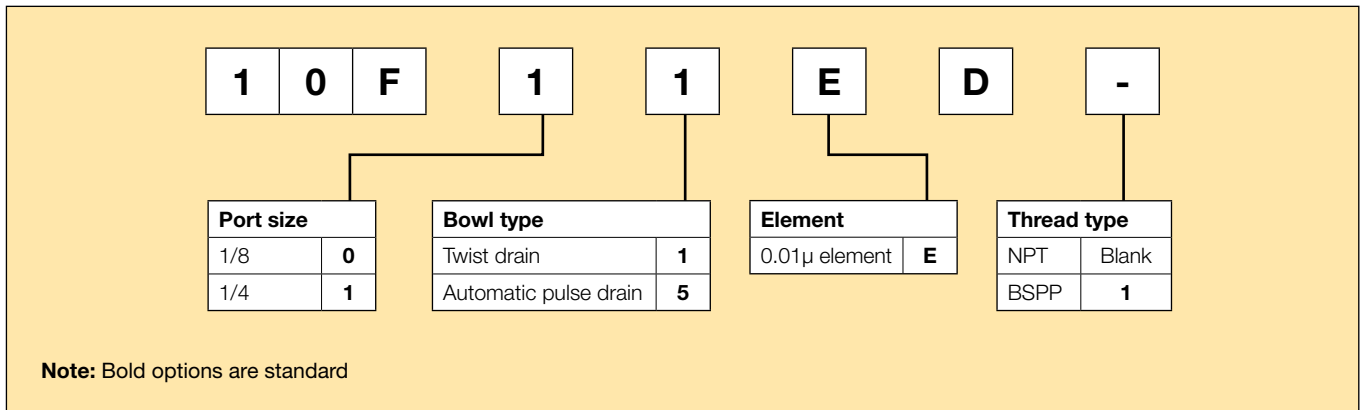

Port size	Description	Order code	Max bar	Height mm	Width mm	Depth mm
G1/8	Twist drain with 5µ element - Poly bowl	10F01ED1	0.7	107	43	39.6
G1/8	Auto pulse drain - 5µ element - Poly bowl	10F05ED1	0.7	107	43	39.6
G1/4	Twist drain with 5µ element - Poly bowl	10F11ED1	0.7	107	43	39.6
G1/4	Auto pulse drain - 5µ element - Poly bowl	10F15ED1	0.7	107	43	39.6
G1/8	Twist drain with 5µ element - Metal bowl	10F03E*	0.7	107	43	39.6
G1/8	Auto pulse drain - 5µ element - Metal bowl	10F07E*	0.7	107	43	39.6
G1/4	Twist drain with 5µ element - Metal bowl	10F13E*	0.7	107	43	39.6
G1/4	Auto pulse drain - 5µ element - Metal bowl	10F17E*	0.7	107	43	39.6

[§] L/s = 6.2 bar inlet and 0.3 bar pressure drop.
[‡] For polycarbonate bowl see Caution on page 2.

Specifications

Automatic pulse drain tube barb		4mm ^{OD} x 0.75 1/8
Bowl capacity		30 cm ³
Operation	Normal pressure drop	0.1 bar
	Maximum recommended pressure drop	0.7 bar
Operating temperature		0°C to 52°C
Max supply pressure	Polycarbonate bowl	0 to 10.3 bar
Standard filtration		0.01 micron
Port size		G1/8 / G1/4
Weight		0.180 gm

Materials of Construction

Body		Zinc
Bowl - Transparent		Polycarbonate
Drains	Twist drain	Body & Stem
		Plastic
		Seals
		Nitrile
	Automatic pulse drain	Piston & Seals
		Nitrile
		Stem, Seat, Adaptor & Washers
		Aluminium
Element holder		Plastic
Filter element		Borosilicate & felt glass fibers 99.97% DOP efficiency
Seals		Nitrile

Dimensions

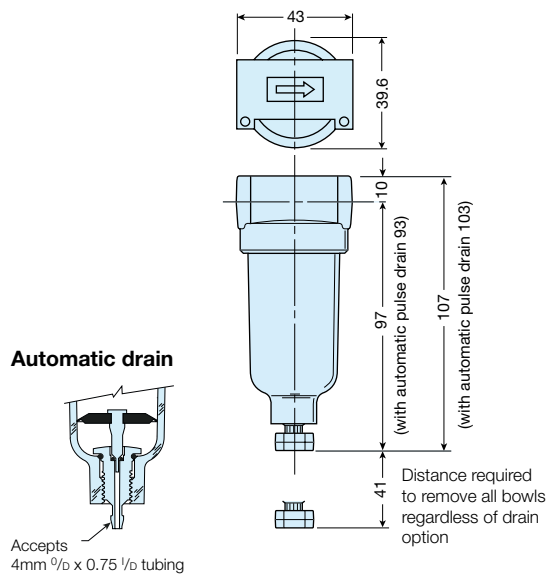

Flow Charts

Grade 6

**Flow Characteristics - 1/8 Inch Ports
 10F01E***

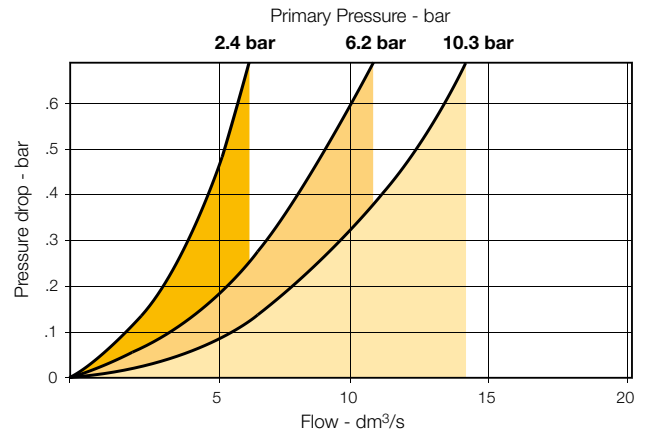

**Flow Characteristics - 1/4 Inch Ports
 10F11E***

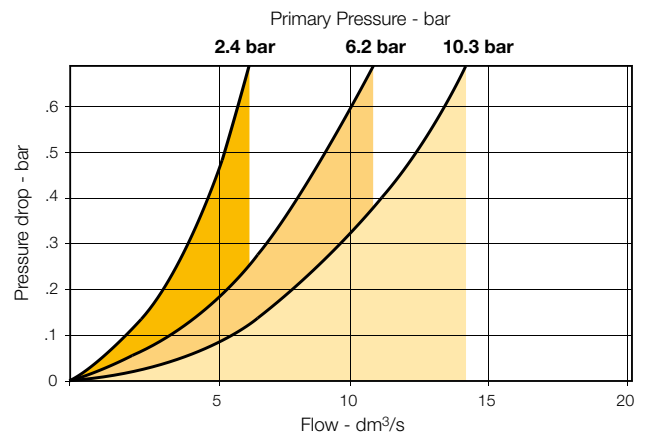

Accessories

Bowl kits, Poly bowl	Automatic pulse drain	PS408P
	Twist drain	PS404P
Filter element kits 0.01 micron		PS446P
Mounting bracket kit		PS417BP

14R Regulators

Symbol

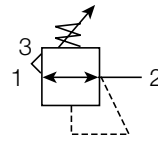

- Unbalanced poppet standard.
- Solid control piston with lip seal for extended life.
- Non-rising adjusting knob.
- Compact, 73,2mm high by 42mm wide.
- High Flow: 1/8" – 6 l/s[§]
 1/4" – 7 l/s[§]

Options:

1	4	R	1	13	F	C	1																																
<table border="1" style="width: 100%; border-collapse: collapse;"> <tr><th colspan="2">Port size</th></tr> <tr><td>1/8" pipe</td><td style="text-align: center;">0</td></tr> <tr><td>1/8" gauge port</td><td style="text-align: center;">0</td></tr> <tr><td>1/4" pipe</td><td style="text-align: center;">1</td></tr> <tr><td>1/8" gauge port</td><td style="text-align: center;">1</td></tr> </table>		Port size		1/8" pipe	0	1/8" gauge port	0	1/4" pipe	1	1/8" gauge port	1	<table border="1" style="width: 100%; border-collapse: collapse;"> <tr><th colspan="2">Pressure range</th></tr> <tr><td colspan="2">Without gauge - Yellow knob</td></tr> <tr><td>2 bar</td><td style="text-align: center;">10</td></tr> <tr><td>4 bar</td><td style="text-align: center;">11</td></tr> <tr><td>8 bar</td><td style="text-align: center;">13</td></tr> </table>		Pressure range		Without gauge - Yellow knob		2 bar	10	4 bar	11	8 bar	13	<table border="1" style="width: 100%; border-collapse: collapse;"> <tr><th colspan="2">Relief</th></tr> <tr><td>Relieving</td><td style="text-align: center;">F</td></tr> <tr><td>Non-relieving</td><td style="text-align: center;">G</td></tr> </table>		Relief		Relieving	F	Non-relieving	G	<table border="1" style="width: 100%; border-collapse: collapse;"> <tr><th colspan="2">Port type</th></tr> <tr><td>NPT</td><td style="text-align: center;">Blank</td></tr> <tr><td>BSPP</td><td style="text-align: center;">1</td></tr> </table>		Port type		NPT	Blank	BSPP	1
Port size																																							
1/8" pipe	0																																						
1/8" gauge port	0																																						
1/4" pipe	1																																						
1/8" gauge port	1																																						
Pressure range																																							
Without gauge - Yellow knob																																							
2 bar	10																																						
4 bar	11																																						
8 bar	13																																						
Relief																																							
Relieving	F																																						
Non-relieving	G																																						
Port type																																							
NPT	Blank																																						
BSPP	1																																						
<p>Note: Bold options are standard</p>																																							

Port size	Description	Order code	Max bar	Height mm	Width mm	Depth mm
G1/8	8 bar - BSPP - without gauge	14R013FC1	20.7	73	42	40
G1/8	8 bar - BSPP - with gauge	14R018F*	20.7	73	42	40
G1/4	8 bar - BSPP - without gauge	14R113FC1	20.7	73	42	40
G1/4	8 bar - BSPP - with gauge	14R118F*	20.7	73	42	40

Note: 31mm dia. hole required for panel mounting.

§ L/s = 6.9 bar inlet, 6.2 bar no flow secondary setting and 0.7 bar pressure drop.

Specifications

Gauge ports	G1/8	
Port size	G1/8 / G1/4	
Operating temperature	0°C to 52°C	
Max supply pressure	0 to 20.7 bar	
Secondary pressure range	Standard pressure	0 to 8 bar
	Medium pressure	0 to 4 bar
	Medium pressure	0 to 2 bar
Weight	140 gm	

Materials of Construction

Adjusting nut	Brass
Adjusting stem & spring	Steel
Body	Zinc
Bonnet, Seat, Piston & Valve poppet	Plastic
Seals	Nitrile

Caution:

Regulator pressure adjustment – The working range of knob adjustment is designed to permit outlet pressures within their full range. Pressure adjustment beyond this range is also possible because the knob is not a limiting device. This is a common characteristic of most industrial regulators, and limiting devices may be obtained only by special design.

For best performance, regulated pressure should always be set by increasing the pressure up to the desired setting.

Dimensions

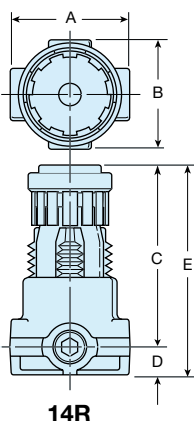

14R

14R Regulator Dimensions

	A	B	C	D	E
14R	42	40	63,5	10	73
14R**L*	1.65	1.56	2.28	0.38	2.68
14RM	A	B	C	D	E
	1.50	1.50	2.36	0.50	2.98
	F	G	H	J	
	1.188	0.594	0.325	0.725	

Flow Charts

**Relief and Flow Characteristics
 14R013F***

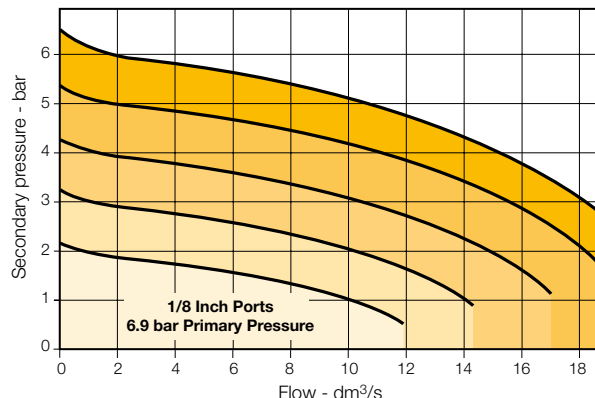

**Relief and Flow Characteristics
 14R113F***

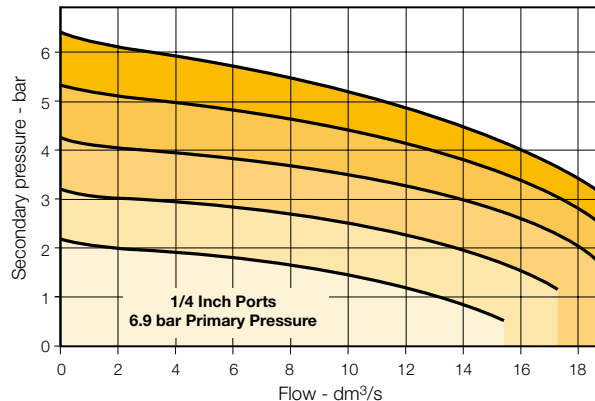

Accessories

Bonnet assembly kit		L01369
Gauges	0 to 2 bar	P3D-KAB1AYN
	0 to 4 bar	P3D-KAB1ALN
	0 to 10 bar	P3D-KAB1ANN
Mounting bracket kit (Includes panel mount nut)		PS417BP
Panel mounts nuts	Plastic	P78652
	Metal	P01531
Service kits	Non-relieving	PS422P
	Relieving	PS423P

Warning

**Product rupture can cause serious injury.
 Do not connect regulator to bottled gas.
 Do not exceed maximum primary pressure rating.**

14E Filter / Regulators



Symbols

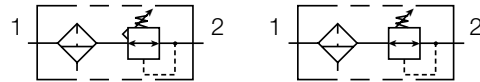

- Excellent water removal efficiency.
- Unbalanced poppet standard.
- Solid control piston for extended life.
- Space saving package offers both filter and regulator features in one integral unit.
- Non-rising adjustment knob.
- Two full flow 1/8" gauge ports.
- High Flow: 1/8" – 7 l/s[§]
1/4" – 8 l/s[§]

Options:

1	4	E	1	1	B	13	F	C	1
Port size		Bowl type		Element		Relief		Port type	
1/8	0	Twist drain	1	5µ element	E	Relieving	F	NPT	Blank
1/4	1	Automatic pulse drain	5			Non-relieving	G	BSPP	1
Pressure range									
Without gauge - Yellow knob									
2 bar						10			
4 bar						11			
8 bar						13			

Note: Bold options are standard

Port size	Description	Order code	Max bar	Height mm	Width mm	Depth mm
G1/8	Twist drain with 5µ element - 8 bar BSPP - Poly bowl without gauge	14E01B13FC1	10.3	158	41	40
G1/8	Auto pulse drain - 5µ element - 8 Bar BSPP - Poly bowl without gauge	14E05B13FC1	10.3	158	41	40
G1/4	Twist drain with 5µ element - 8 Bar BSPP - Poly bowl without gauge	14E11B13FC1	10.3	158	41	40
G1/4	Auto pulse drain - 5µ element - 8 Bar BSPP - Poly bowl without gauge	14E15B13FC1	10.3	158	41	40
G1/8	Twist drain with 5µ element - 8 Bar BSPP - Metal bowl without gauge	14E03B13F*	10.3	158	41	40
G1/8	Auto pulse drain - 5µ element - 8 Bar BSPP - Metal bowl without gauge	14E07B13F*	10.3	158	41	40
G1/4	Twist drain with 5µ element - 8 Bar BSPP - Metal bowl without gauge	14E13B13F*	10.3	158	41	40
G1/4	Auto pulse drain - 5µ element - 8 Bar BSPP - Metal bowl without gauge	14E17B13F*	10.3	158	41	40

§ L/s = 6.9 bar inlet, 6.2 bar no flow secondary setting and 0.7 bar pressure drop.

‡ For polycarbonate bowl see Caution on page 2.

Note: 31mm hole required for panel mounting.

Specifications

Automatic pulse drain tube barb	4mm ^{OD} x 0.75 1/8
Bowl capacity	30 cm ³
Gauge ports (2) (can be used for full flow)	G1/8
Port size	G1/8 / G1/4
Operating temperature	0°C to 52°C
Secondary pressure	Standard pressure 0 to 8 bar
pressure range	Medium pressure 0 to 4 bar
	Medium pressure 0 to 2 bar
Weight	0.180 gm

Materials of Construction

Adjusting nut	Brass
Adjusting stem & spring	Steel
Body	Zinc
Bonnet, Knob, Seat, Piston, Holder & Deflector	Plastic
Bowl - Transparent	Polycarbonate
Drains	Twist drain Body & Stem Plastic
	Seals Nitrile
	Automatic pulse drain Piston & Seals Nitrile
	Stem, Seat, Adaptor & Washers Aluminium
Filter elements - 5 micron (Standard)	Plastic
Seals	Nitrile

Caution:

Regulator pressure adjustment – The working range of knob adjustment is designed to permit outlet pressures within their full range. Pressure adjustment beyond this range is also possible because the knob is not a limiting device. This is a common characteristic of most industrial regulators, and limiting devices may be obtained only by special design.

For best performance, regulated pressure should always be set by increasing the pressure up to the desired setting.

Dimensions

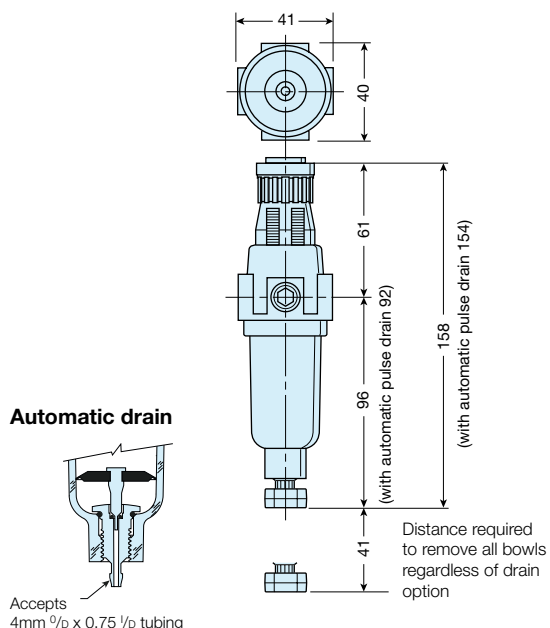

Flow Charts

Relief and Flow Characteristics 14E01B13F*

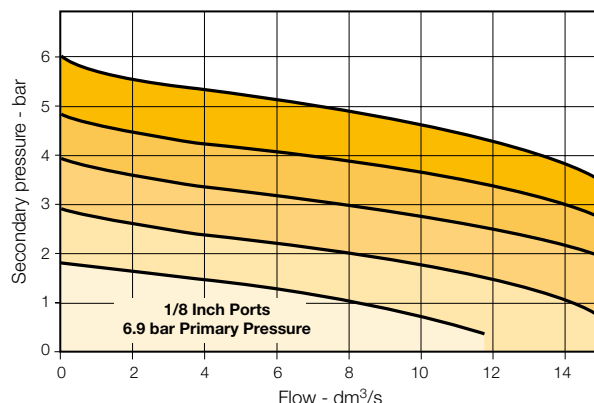

Relief and Flow Characteristics 14E11B13F*

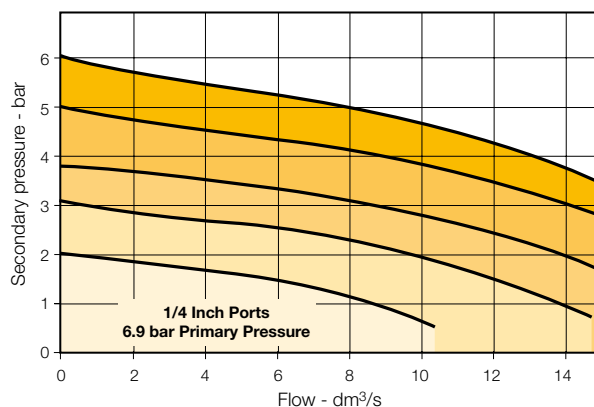

Accessories

Bowl kits, Poly bowl	Automatic pulse drain	PS408P
	Twist drain	PS404P
Filter element kits	40 micron	PS401P
	5 micron	PS403P
Gauges - 1/8	0 to 2 bar	P3D-KAB1AYN
	0 to 4 bar	P3D-KAB1ALN
	0 to 10 bar	P3D-KAB1ANN
Mounting bracket kit (Includes panel mount nut)		PS417BP
Panel mounts nuts	Plastic	P78652
Service kits	Non-relieving	PS422P
	Relieving	PS423P

Warning
 Product rupture can cause serious injury.
 Do not exceed maximum primary pressure rating.

10L Mist Lubricators

Symbol



- Proportional oil delivery over a wide range of air flows.
- Precision needle valve assures repeatable oil delivery and provides simple adjustment of delivery rate.
- Ideal for low and high flow applications with changing air flow.
- Transparent sight dome for 360° visibility.
- High Flow: 1/8" – 9 l/s[§]
 1/4" – 10 l/s[§]

Options:

0	4	L	1	0	G	B	-		
			Port size				Thread type		
			1/8	0				NPT	Blank
			1/4	1				BSPP	1

Note: Bold options are standard

Port size	Description	Order code	Max bar	Height mm	Width mm	Depth mm
G1/8	BSPP no drain - Poly bowl	14L00GB1	10.3	147	44	40
G1/4	BSPP no drain - Poly bowl	14L10GB1	10.3	147	44	40

[§] L/s = 6.2 bar inlet and 0.3 bar pressure drop.
[‡] For polycarbonate bowl see Caution on page 2.

Specifications

Bowl capacity	30 cm ³
Minimum flow for lubrication	0.2 l/s at 6.9 bar
Port size	G1/8 / G1/4
Operating temperature	0°C to 52°C
Max supply pressure	Polycarbonate bowl 0 to 10.3 bar
Weight	0.180 gm

Materials of Construction

Body	Zinc
Bowl - Transparent	Polycarbonate
Seals	Nitrile
Sight dome	Polycarbonate

Flow Charts

**Flow Characteristics - 1/8 Inch Ports
 04L00G***

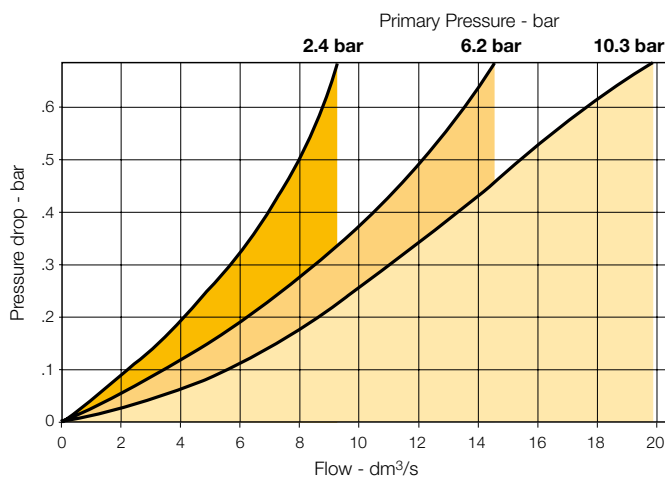

**Flow Characteristics - 1/4 Inch Ports
 04L00G***

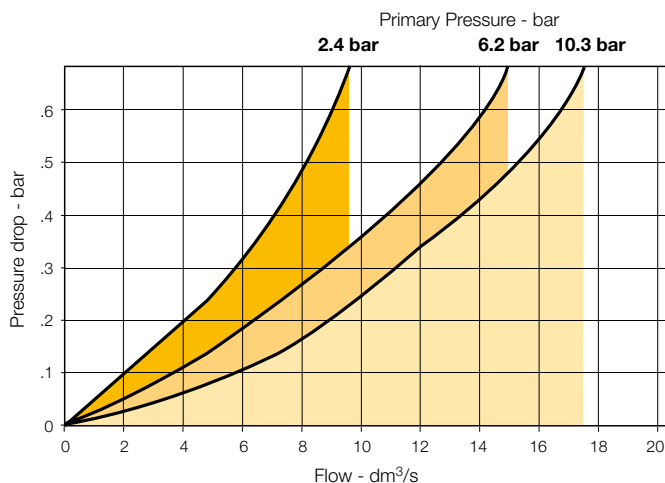

Dimensions

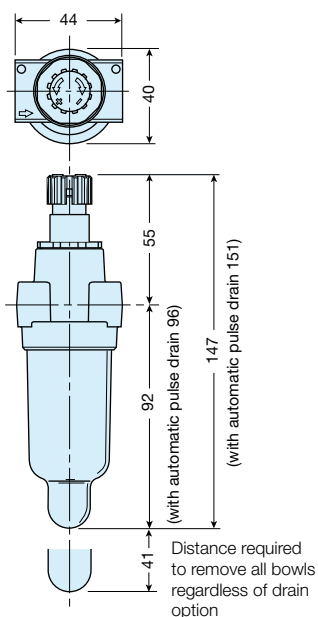

Accessories

Bowl kits, Poly bowl	No drain	PS421P
----------------------	----------	---------------

Mounting Bracket Kits

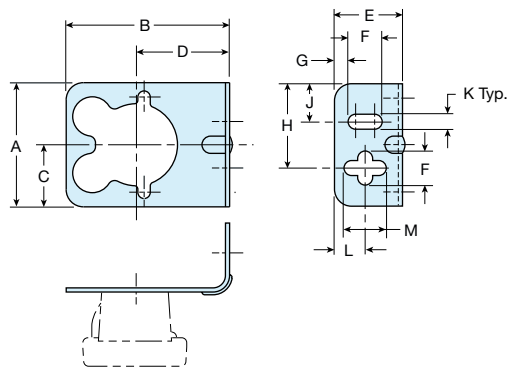

PS417BP

(Includes Panel Mount Nut)

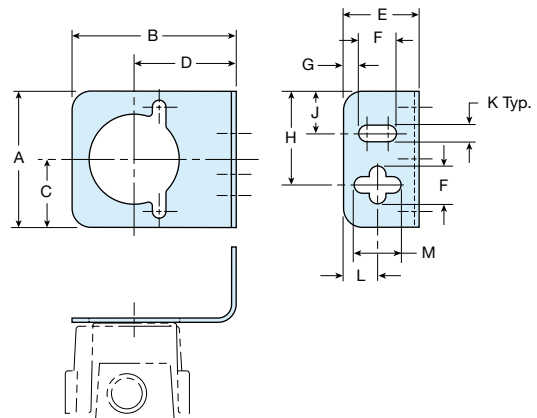

PS419

Dimensions (mm)

A	B	C	D	E	F	G	H	J	K	L	M	Kit
46	60	23	34	25	13	5	31	14	6	11	16	PS417BP (10F, 14F, 14R, 14E)
46	55	23	34	25	13	5	31	14	6	11	16	PS419 (04L)

Parker Worldwide

Europe, Middle East, Africa

AE – United Arab Emirates, Dubai
Tel: +971 4 8127100
parker.me@parker.com

AT – Austria, Wiener Neustadt
Tel: +43 (0)2622 23501-0
parker.austria@parker.com

AT – Eastern Europe, Wiener Neustadt
Tel: +43 (0)2622 23501 900
parker.easteurope@parker.com

AZ – Azerbaijan, Baku
Tel: +994 50 2233 458
parker.azerbaijan@parker.com

BE/LU – Belgium, Nivelles
Tel: +32 (0)67 280 900
parker.belgium@parker.com

BG – Bulgaria, Sofia
Tel: +359 2 980 1344
parker.bulgaria@parker.com

BY – Belarus, Minsk
Tel: +48 (0)22 573 24 00
parker.poland@parker.com

CH – Switzerland, Etoy
Tel: +41 (0)21 821 87 00
parker.switzerland@parker.com

CZ – Czech Republic, Klecany
Tel: +420 284 083 111
parker.czechrepublic@parker.com

DE – Germany, Kaarst
Tel: +49 (0)2131 4016 0
parker.germany@parker.com

DK – Denmark, Ballerup
Tel: +45 43 56 04 00
parker.denmark@parker.com

ES – Spain, Madrid
Tel: +34 902 330 001
parker.spain@parker.com

FI – Finland, Vantaa
Tel: +358 (0)20 753 2500
parker.finland@parker.com

FR – France, Contamine s/Arve
Tel: +33 (0)4 50 25 80 25
parker.france@parker.com

GR – Greece, Athens
Tel: +30 210 933 6450
parker.greece@parker.com

HU – Hungary, Budaörs
Tel: +36 23 885 470
parker.hungary@parker.com

IE – Ireland, Dublin
Tel: +353 (0)1 466 6370
parker.ireland@parker.com

IL – Israel
Tel: +39 02 45 19 21
parker.israel@parker.com

IT – Italy, Corsico (MI)
Tel: +39 02 45 19 21
parker.italy@parker.com

KZ – Kazakhstan, Almaty
Tel: +7 7273 561 000
parker.easteurope@parker.com

NL – The Netherlands, Oldenzaal
Tel: +31 (0)541 585 000
parker.nl@parker.com

NO – Norway, Asker
Tel: +47 66 75 34 00
parker.norway@parker.com

PL – Poland, Warsaw
Tel: +48 (0)22 573 24 00
parker.poland@parker.com

PT – Portugal
Tel: +351 22 999 7360
parker.portugal@parker.com

RO – Romania, Bucharest
Tel: +40 21 252 1382
parker.romania@parker.com

RU – Russia, Moscow
Tel: +7 495 645-2156
parker.russia@parker.com

SE – Sweden, Spånga
Tel: +46 (0)8 59 79 50 00
parker.sweden@parker.com

SL – Slovenia, Novo Mesto
Tel: +386 7 337 6650
parker.slovenia@parker.com

TR – Turkey, Istanbul
Tel: +90 216 4997081
parker.turkey@parker.com

UA – Ukraine, Kiev
Tel: +48 (0)22 573 24 00
parker.poland@parker.com

UK – United Kingdom, Warwick
Tel: +44 (0)1926 317 878
parker.uk@parker.com

ZA – South Africa, Kempton Park
Tel: +27 (0)11 961 0700
parker.southafrica@parker.com

North America

CA – Canada, Milton, Ontario
Tel: +1 905 693 3000

US – USA, Cleveland
Tel: +1 216 896 3000

Asia Pacific

AU – Australia, Castle Hill
Tel: +61 (0)2-9634 7777

CN – China, Shanghai
Tel: +86 21 2899 5000

HK – Hong Kong
Tel: +852 2428 8008

IN – India, Mumbai
Tel: +91 22 6513 7081-85

JP – Japan, Tokyo
Tel: +81 (0)3 6408 3901

KR – South Korea, Seoul
Tel: +82 2 559 0400

MY – Malaysia, Shah Alam
Tel: +60 3 7849 0800

NZ – New Zealand, Mt Wellington
Tel: +64 9 574 1744

SG – Singapore
Tel: +65 6887 6300

TH – Thailand, Bangkok
Tel: +662 186 7000

TW – Taiwan, Taipei
Tel: +886 2 2298 8987

South America

AR – Argentina, Buenos Aires
Tel: +54 3327 44 4129

BR – Brazil, Sao Jose dos Campos
Tel: +55 800 727 5374

CL – Chile, Santiago
Tel: +56 2 623 1216

MX – Mexico, Toluca
Tel: +52 72 2275 4200

European Product Information Centre

Free phone: 00 800 27 27 5374

(from AT, BE, CH, CZ, DE, DK, EE, ES, FI, FR, IE, IL, IS, IT, LU, MT, NL, NO, PL, PT, RU, SE, SK, UK, ZA)



Parker Hannifin Ltd.

Tachbrook Park Drive
Tachbrook Park,
Warwick, CV34 6TU
United Kingdom
Tel.: +44 (0) 1926 317 878
Fax: +44 (0) 1926 317 855
parker.uk@parker.com
www.parker.com