

- > **Port size: M5, G1/8 ... G1/2**
- > **Compact design**
- > **Captive regulating needle will not blow out when unscrewed**



### Technical features

#### Medium:

Compressed air, filtered, lubricated and non-lubricated, inert gases

#### Operation:

Exhaust flow regulator/silencer

#### Operating pressure:

1 ... 10 bar (14 ... 145 psi)

#### Port size:

M5, G1/8, G1/4, G3/8, G1/2

#### Mounting:

Directly in the exhaust port 'Allen' key adjustment for flow regulation

#### Ambient/Media temperature:

-20 ... +80°C max. (-4 ... +176°F)

Air supply must be dry enough to avoid ice formation at temperatures below +2°C (+35°F)

#### Materials:

Body and washer: PA  
 Silencer: Porous PUR  
 Adjusting screw: high tensile zinc plated steel  
**M5:**  
 Body: PA  
 Adjusting screw: high tensile zinc plated steel

### Technical data, standard models

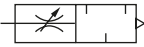
Symbol	Port size	Flow factor C *1)	Cv	Kv *2)	Weight (kg)	Model
	M5	0,3	0,07	0,054	0,001	T20M0500
	G1/8A	1,6	0,4	0,34	0,003	T20C1800
	G1/4A	3,2	0,8	0,68	0,007	T20C2800
	G3/8A	6,9	1,7	1,47	0,020	T20C3800
	G1/2A	10	2,4	2,13	0,040	T20C4800

\*1) Measured in dm<sup>3</sup>/(s.bar)

\*2) Measured in m<sup>3</sup>/h

### Options selector

**T20★★★★00**

Thread	Substitute	Port size	Substitute
Metric, M5 only	<b>M</b>	M5	<b>05</b>
ISO G	<b>C</b>	1/8"	<b>18</b>
		1/4"	<b>28</b>
		3/8"	<b>38</b>
		1/2"	<b>48</b>

Performance characteristics for T20 Series (at 6 bar inlet pressure)

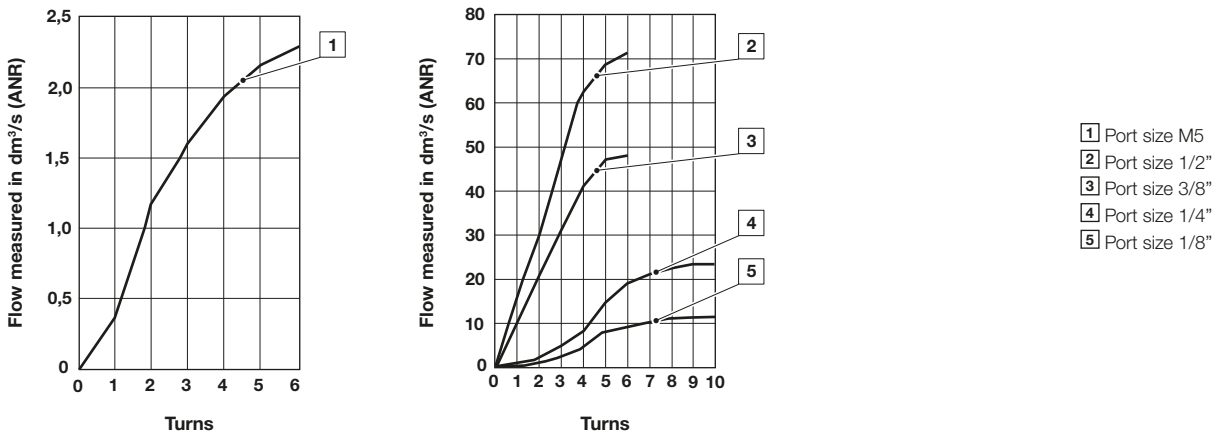

Dimensions

Dimensions in mm  
Projection/First angle

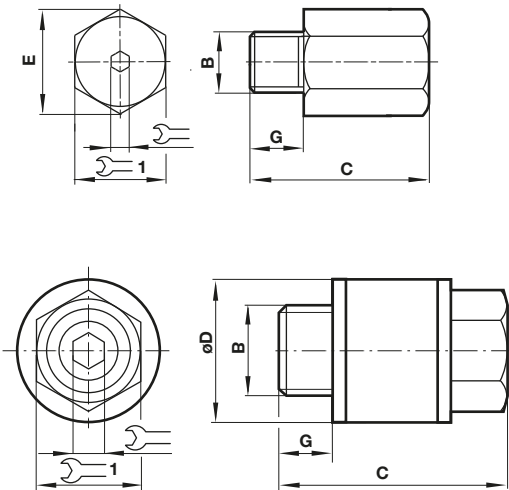

B	G	C	E			Model
M5	5	16	9,5	1,5	8	T20M0500

B	C	øD	G			Model
G1/8A	20,5	15	6	2,5	13	T20C1800
G1/4A	29	18	7	4	15	T20C2800
G3/8A	38	24	8	6	20	T20C3800
G1/2A	50	30	10	8	25	T20C4800

Warning

These products are intended for use in industrial compressed air systems only. Do not use these products where pressures and temperatures can exceed those listed under »**Technical features/data**«.

Before using these products with fluids other than those specified, for non-industrial applications, life-support systems or other applications not within published specifications, consult IMI Precision Engineering, Norgren Ltd.

Through misuse, age, or malfunction, components used in fluid power systems can fail in various modes. The system designer is warned to consider the failure modes of all component parts used in fluid power systems and to provide adequate safeguards to prevent personal injury or damage to equipment in the event of such failure.

System designers must provide a warning to end users in the system instructional manual if protection against a failure mode cannot be adequately provided.

System designers and end users are cautioned to review specific warnings found in instruction sheets packed and shipped with these products.